

[®]
SECO SM3000
AC Drive

Installation and Operation Manual

Operating manual for AC Adjustable Frequency Drive

230 VAC Version
SM3201-00000..... 1 HP

460 VAC Version
SM3401-00000..... 1 HP

Table of contents

	Information on the operating manual	Page 4
A.1	Safety Instructions	Page 5
1.	Technical Specifications	Page 6... 8
1.1	Physical assembly	
1.2	Technical data	
1.3	Dimensions	
2.	Electrical Connections and Functions	Page 9... 19
2.1	Wiring diagram	
2.2	Power connection	
2.3	Control signals connection	
2.4	Standard control functions	
3.	Monitoring and Fault Diagnostics	Pages 20 ...22
3.1	Operational display	
3.2	Overload protection	
3.3	Fault diagnostics	
3.4	Repair	

Information on the Operating Manual

This operating manual applies to the SM3000 series of AC Motor controllers. It describes the connections and basic functions of the standard models.

The KP100 keypad which is available as an option, helps you to program the various parameters of the drive and offers you further control functions. A separate operating manual is supplied with the KP100. Ask for LIM55434

If you have a non standard version, specifically designed to meet your requirements, a specific operating manual will be supplied.

Symbols used and their specific meaning:



CAUTION! Danger of death by electrocution



CAUTION! Absolutely essential

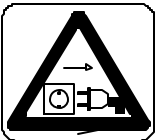

Before accessing the inside of the inverter, disconnect it from the mains supply and wait for at least 2 min.

Wait >2 min



FORBIDDEN! Incorrect operation, may lead to damage.

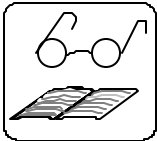

Information, advice, tip

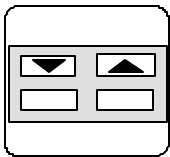

Setting can be changed using the keypad KP100

A.1 Safety Instructions



Because of the high operating voltage (230 or 460 V) and the rotation of the motor connected to the AC Drive, operation of the product is potentially fatal.

To avoid serious injury or considerable damage, only qualified personnel who are familiar with electrical drive equipment should work on this product.

Before installing and commissioning, it is important for such personnel to read carefully the operating instructions and safety warnings.



Electronic equipment can never be 100% reliable. The user is responsible for ensuring that in case of failure of the equipment, the drive fails in a safe condition.

Regulations

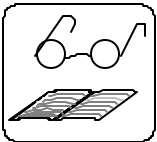

The unit must be installed in accordance with the National Electrical Code and any applicable local codes

1. Technical Specifications

1.1 Physical assembly

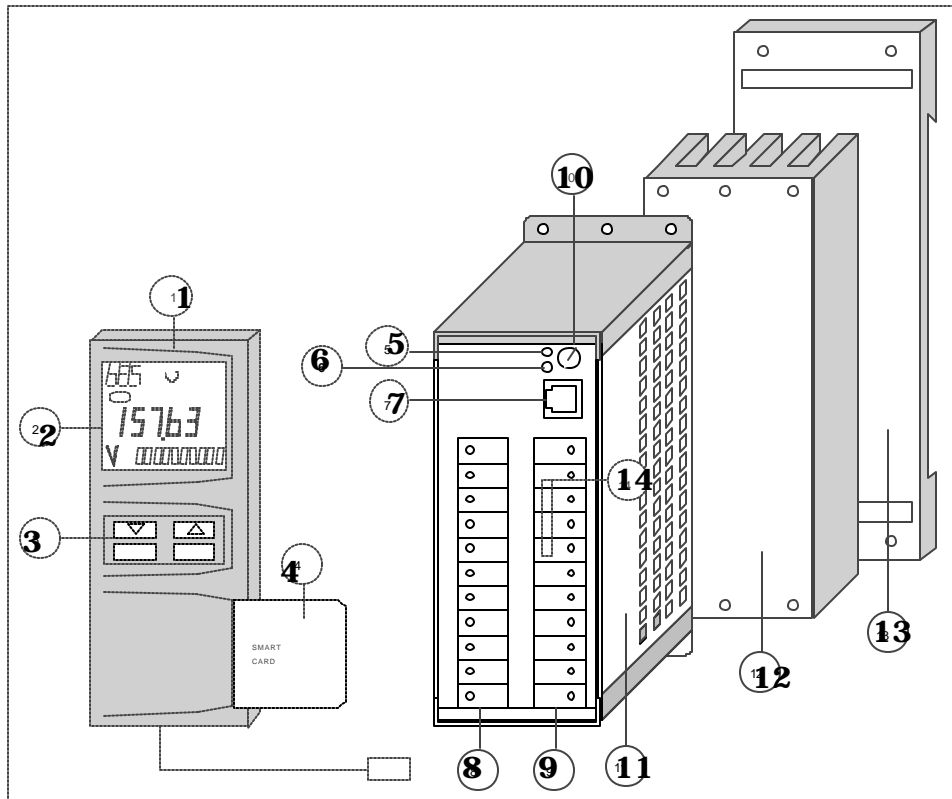

- 1 Keypad (KP100)¹
- 2 LCD - display (140 characters)
- 3 Membrane Keypad
- 4 SmartCard WARNER¹
- 5 LED H2 (green) - operating
- 6 LED H1 (yellow) - fault indicator
- 7 Connector socket for keypad KP100
- 8 Terminal block X5 - power connections
- 9 Terminal block X1 - control signal connections
- 10 Potentiometer P1 - internal set point
- 11 SM 3000 - basic unit
- 12 Heat sink¹
- 13 Top hat rail¹
- 14 Jumper strip X2

¹ Accessories

Output parameters

	Code	Units	SM3201	SM3401
Standard motor, 4 poles rated nominal power	P	HP	1	1
KVA Rating	S	VA	1.3	1.3
Nominal current	I	A	3.2	1.9
Load Capacity		%	110	
Overload, for 60 sec		%	150	
Output voltage	U	V	3 x 0...230	3x0...460
Output frequency	f	Hz	0...400	
Frequency steps	f	%	0.1% of FMAX, min. 0.05 Hz	
Type of load			resistive / inductive	
Overload current for 60 sec	IMAX	A	4.8	2.9
Length of the motor cables			max. 15 ft, if > 15ft use output chokes	
Short-circuit protection between phases			At terminals	
Ground short-circuit protection			At power on	

Input parameters

Supply voltage	U	V	1 x 230 V (+15% / - 20%)	3x400(-15%) ...460(+10%)
Mains frequency	f	Hz	50 / 60 Hz +/- 10%	
Power factor		cos	>0.97 (active power only)	
Gauge of the connecting wires	A	mm ²	1.5	
Recommended mains fuses		A	1 x 10 AT	3 x 10 AT
Efficiency at nominal load		%	95	94
Internal losses at f=50 Hz, I nominal	P	W	35	45
Maximum Unbalance of supply voltage	U	%	3	3

Physical parameters

Dimensions	LxHxP	mm	60 x 156 x 100	
Weight		lb	approx. 2 lb	
Protection class, unit connected			NEMA 1	
Mounting position			Vertical on wall	

Ambient conditions

Max. ambient temperature	T	°C	40	
Output power derating relative to the operating altitude	H	m	> than 1000 m: derating of 5% per additional 1000 m (2000 m max.)	
Output power derating relative to the ambient temperature		%/°C	3% per °C over the ambient of 40°C Max. ambient temperature 50°C	
Relative humidity		%	15...85, not condensing	
Vibration				
Storage temperature	T	°C	-25 to + 55	
Shipping temperature	T	°C	-25 to + 70	

1.3 Dimensions

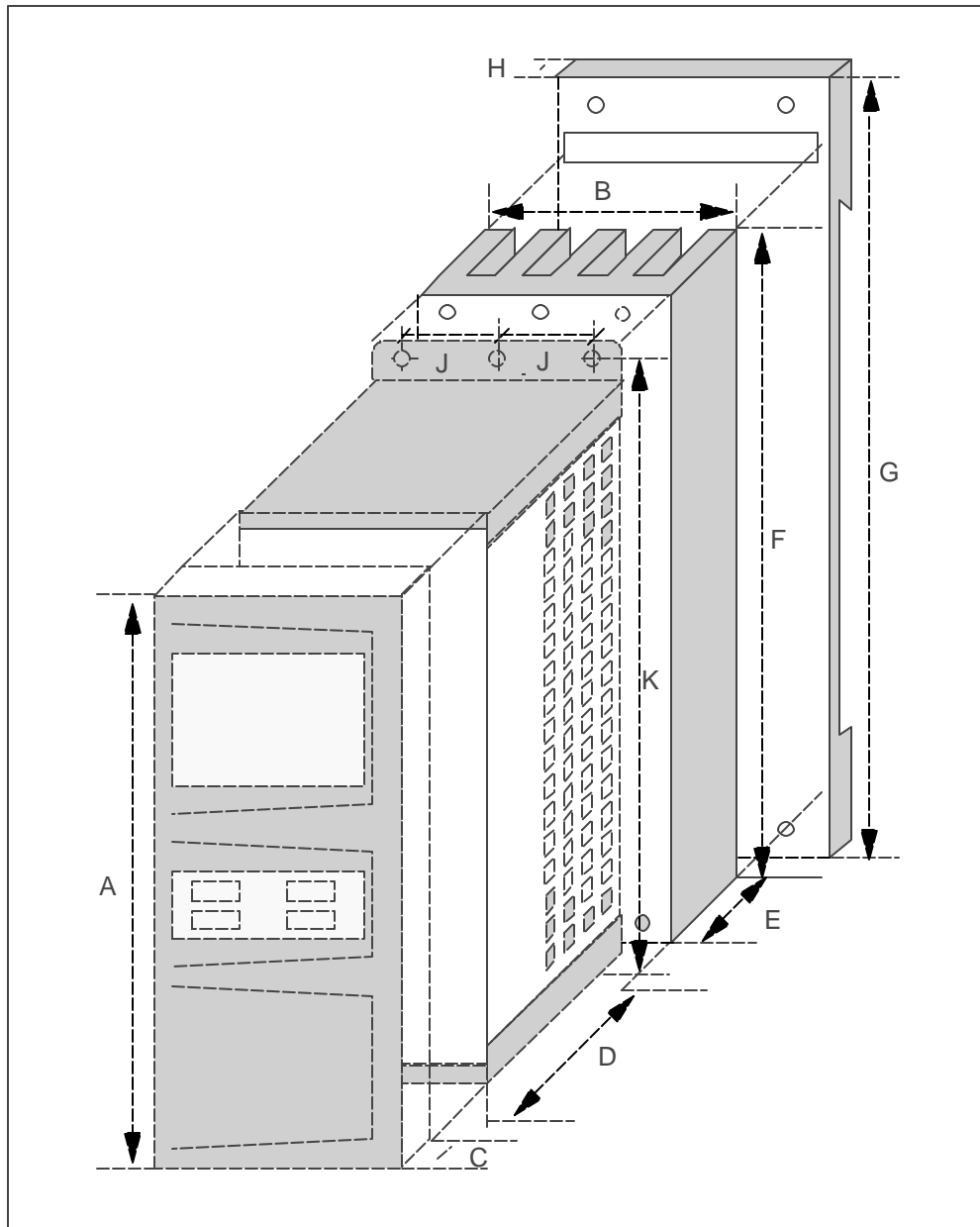

	A	B	C	D	E	F	G	H	J	K
Basic unit		65		132.5		182.5			20	170
Keypad	160	65	21							
Heat sink		65			65	182.5				
Mounting rail		65					245	8		

All dimensions in mm

2. Electrical Connections and functions

2.1 Wiring diagram

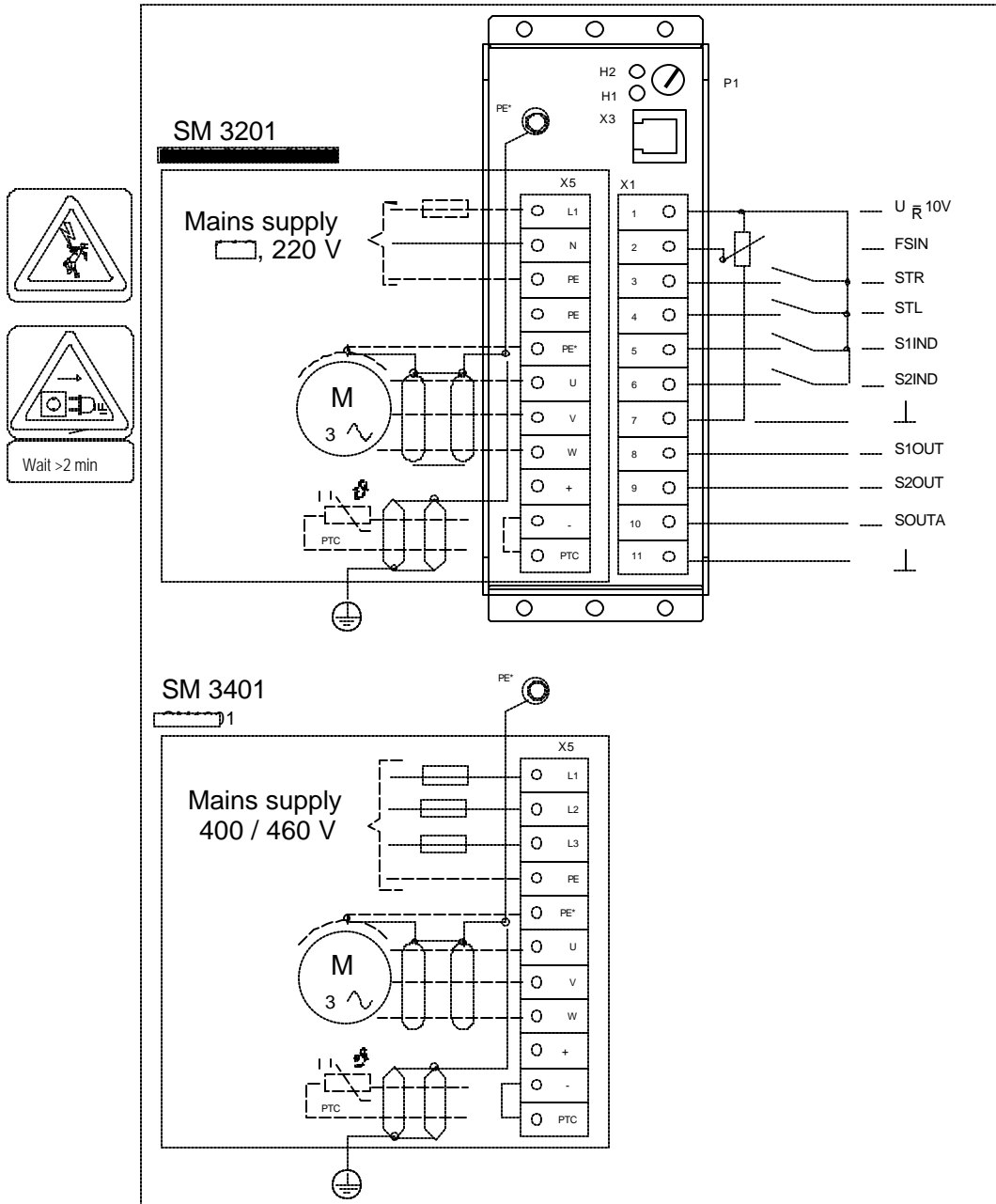

Terminal abbreviations and descriptions

X1	Abbreviation	Description
1	UR	Reference voltage + 10 V
2	FSIN	Set frequency input
3	STR	Input START clockwise
4	STL	Input START counter clockwise
5	S1IND	Programmable input 1
6	S2IND	Programmable input 2
7	Ground	Control connection reference
8	S1OUT	Programmable output 1
9	S2OUT	Programmable output 2
10	SOUTA	Analog output
11	Ground	Control connection reference

X5	
Description	
L1,L2,L3,PE	Power supply connections 400 / 460 V
PE*,U,V,W	Motor connections
- / +	Connections for the external brake chopper
PTC / -	Connections for the motor PTC resistor
PE*	Shield connection

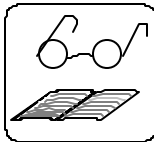

The SM3000 meets the interference requirements of the VDE0843/IEC 801 parts 2 - 6. To meet these radio interference regulations it is necessary for the shield of the motor cable to be connected only to the terminal <PE*> and the neutral connecting cable of the power supply to <PE>.

To prevent interference, a mains supply filter should be used (Part No CM055).

Cooling

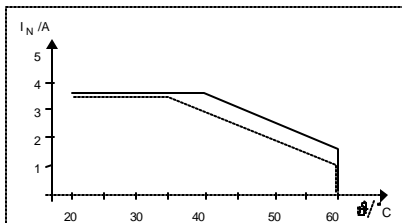

The specifications will be guaranteed without reduction of performance if the inverter is mounted on a suitable wall.

	Material	Surface	Switching frequency
???	Alu. untreated	0.25 m ²	8 kHz
-----	Painted steel	0.25 m ²	8 kHz

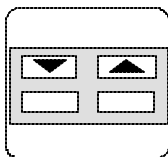

The switching frequency of the PWM modulation can be changed using the keypad to modify parameter <74>. This increases the power losses in the inverter and the rating must be reduced.

2.2 Power connections

Connection of the power supply



You must wait 60 seconds between successive power ups of the inverter.
During start up of the equipment or after an emergency STOP, it is possible to power up the inverter immediately.



The unit must be grounded.

The unit must be fused in accordance with the National Electrical Code.

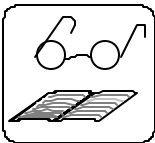

Connection of the SM 3201



The mains power is connected to terminals X5/L1,N,PE.
Technical data see 1.2

Never connect 400/460 V between terminals X5/L1 and X5/N.
The unit will be damaged through the excessive voltage.

Connection of the SM 3401

The mains power is connected to terminals X5/L1,2,L3,PE.
Technical data see 1.2

Connection of the motor ? .

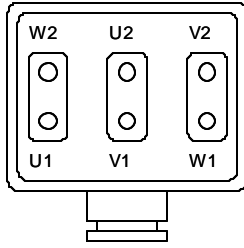

Connection of the SM 32000

The connections to the motor are made on terminals PE, U, V, W of the terminal block X5.

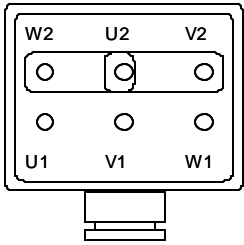

Connection of the SM 3400

The connections to the motor is made on the terminals PE, U, V, W of the terminal block X5.

Connection of the PTC (PTC resistor built in the motor stator)



The PTC resistor built in the stator winding of the motor to indicate its temperature is connected via terminals PTC and - of terminal block X5. If the PTC is not connected, a jumper must be put between those terminals.

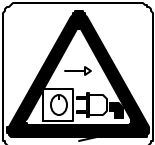

Caution: The connections of the PTC are on the power terminal. Before connecting the PTC, the inverter must be disconnected from the mains.

The resistance of the PTC resistor must be, $> 3 \text{ k}\Omega$, at its operating temperature.

Wait $> 2 \text{ min}$

Brake chopper Connection

General

If the motor speed is higher than the synchronous speed at the applied frequency, the motor, working as a generator, feeds back energy. The motor is slowed down by the inverter and this energy increases the voltage on the DC bus.

Depending on the energy level involved, in order to ensure braking operation without an overvoltage trip, an external brake chopper must be used. The brake chopper converts the regenerative braking energy into heat in a load resistor and prevents an over-voltage trip from occurring.

Connection of the SM 3201

The brake chopper is connected to terminal + and - of terminal block X5.

Caution:

The option CM054 and RB200 (board and resistor) is a OEM-kit and has no protection, either for the operator or the unit. The user must ensure that, during installation and commissioning no injury to human personnel or damage to the material can occur.

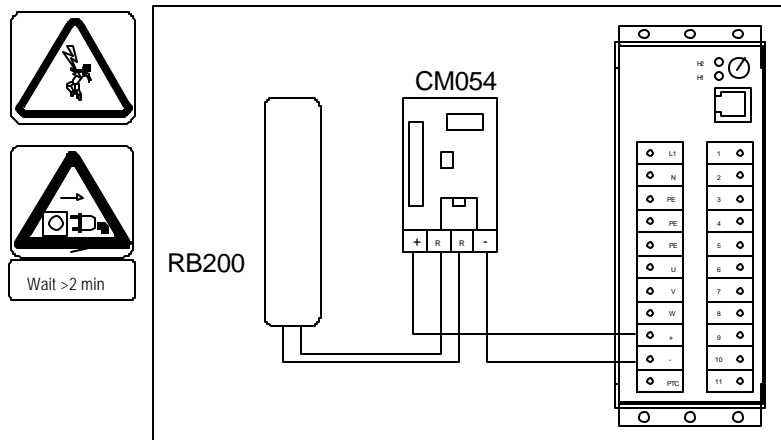

2.3 Control signal connection

Specification of inputs and outputs

Signal	Specification																
Output X1/1 <UR>	? Reference voltage +10V (? 2%) ? Not short-circuit proof ? Maximum load 15 mA																
Input X1/2 <FSINA>	? Several inverters may be cascaded using the set point voltage ? 10 bits resolution ? Internal resistance 100 k? ? Voltage 0...10 V, current 0 (4)...20 mA ? Linearity < 2%																
Factory settings	<table border="1"> <thead> <tr> <th></th> <th>Current</th> <th>Voltage</th> <th>Output</th> </tr> </thead> <tbody> <tr> <td>STOP</td> <td>0 A</td> <td>0 V</td> <td>Locked</td> </tr> <tr> <td>FMIN</td> <td>4 mA</td> <td>0.1 V</td> <td>0.5 Hz</td> </tr> <tr> <td>FMAX</td> <td>20 mA</td> <td>10 V</td> <td>50 Hz</td> </tr> </tbody> </table>		Current	Voltage	Output	STOP	0 A	0 V	Locked	FMIN	4 mA	0.1 V	0.5 Hz	FMAX	20 mA	10 V	50 Hz
	Current	Voltage	Output														
STOP	0 A	0 V	Locked														
FMIN	4 mA	0.1 V	0.5 Hz														
FMAX	20 mA	10 V	50 Hz														
Inputs X1/3 <STR> X1/4 <STL> X1/5 <S1IND> X1/6 <S2IND>	? Input voltage 0... 30 V ? Switching threshold OFF < 2V, ON > 8V ? Internal resistance 2.4 k? ? Response time 1... 8.2 ms																
Outputs X1/8 <S1OUT> X1/9 <S2OUT> Digital	? Open collector output UB max. 30 V ? Max. current = 50 mA max. /Ri = 100 ? (Not short-circuit proof) ? Active low = 0, switches to ground																
Output ? X1/10 <SOUTA> analog	? Output voltage 0 ... 10 V (? 2%) ? Max. current = 50 mA max. /Ri = 100 ? Not short-circuit proof ? 10 bits resolution																
Output? X1/10 <SOUTA> digital	? Open collector UB = 15 V max. ? Max. current = 50 mA max. /Ri = 100 ? Not short-circuit proof																

? see jumper position X2 / J3 and J4

2.4 Standard control functions



Mains Power switching with STL and STR

For safety reasons, the inverter must not be switched on to the mains supply with one of the start inputs STR or STL on.

The start function will only operate if STL or STR is activated after power on and self test is completed.

Analog frequency set point <FSINA>

The output frequency can be set externally via terminals X1/2 and 7. There are three selections:

1. Using a potentiometer: R = 4.7 ... 10 k Ω , Jumper position 3
2. An external DC voltage 0 (2) ... 10 VDC
3. An external DC current 0 (4) ... 20 mA DC

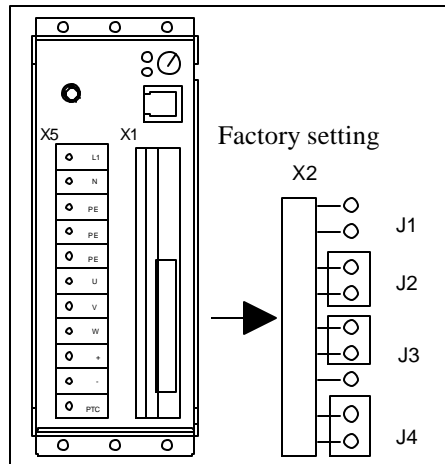

Input FSINA is selected on the jumper strip X2, accessible after removing the terminal block X1.

- No jumper
- Jumper in place

Pos.	J1	J2	Function	Remarks
1	<input type="checkbox"/> <input type="checkbox"/>	<input type="checkbox"/> <input type="checkbox"/>	Input 2 ...10 V	Variation < 2%
2	<input checked="" type="checkbox"/> <input checked="" type="checkbox"/>	<input type="checkbox"/> <input type="checkbox"/>	Input 4 ... 20 mA	R _i = 500 ?
3	<input type="checkbox"/> <input type="checkbox"/>	<input checked="" type="checkbox"/> <input checked="" type="checkbox"/>	Input 0 ...10 V	Variation < 2%, R _i = 500 ? *
4	<input checked="" type="checkbox"/> <input checked="" type="checkbox"/>	<input type="checkbox"/> <input type="checkbox"/>	Input 0 ... 20 mA	R _i = 500 ?

* Factory setting

To activate these settings program Parameter 04-FSSEL = 4

Control functions

The direction of rotation is selected by the inputs STL and STR using two switched contacts, as shown on the wiring diagram.

Alternatively, the direction of rotation may be selected by two external voltage signals in accordance with the control connection information.

START

The inverter starts as soon one of the control signals STL or STR and a frequency demand of at least 0.5 Hz at FSINA input, are present at the same time.

STOP / Slowdown to zero speed

When both signals STL and STR are present, the inverter reduces the motor speed to zero. Restarting is automatic as soon as one of the two signal is removed.

Reversing

The direction of rotation is reversed when the control signal moves from one input to the other. The overlapping time must be at least 8 ms.

Format

Logic	Control signal	Switching contact
0	< 2 V	Open
1	> 8 V	Close

Logical functions

STL	STR	Explanation
0	0	STOP, motor coasts to rest
1	0	START, counter clockwise rotation CCW
0	1	START, clockwise rotation CW
1	1	Motor brakes to zero speed
0	?	Reverse the direction of the rotation
1	?	Switching from one input to the other

Preset frequencies FF2, FF3, FF4

In addition to the frequency set through the FSINA input, the output frequency can be set through the inputs X1/5 <S1IND> and X1/6 <S2IND> available on the terminal block X1. There are three programmable pre-set frequencies available.

Format

Logic	Control signal	Switching contact
0	< 2 V	Open
1	> 8 V	Close

Logical functions

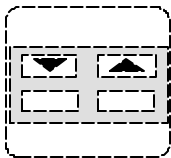

S1IND	S2IND	Explanation	Fact. setting
0	0	Input FSINA active	0 ... 50 Hz
1	0	Pre-set FF2 active	3 Hz
0	1	Pre-set FF3 active	15 Hz
1	1	Pre-set FF4 active	30 Hz

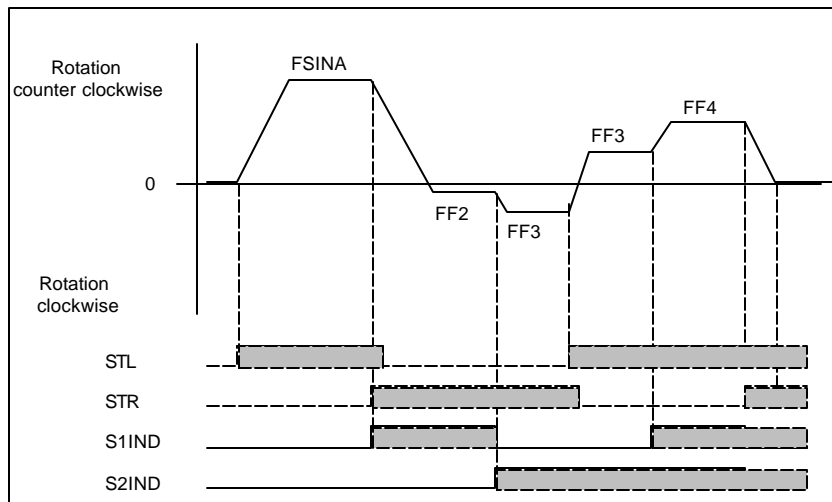

Assigned output signals

Ready, X1/8, <S1OUT>

This output becomes inactive (relay de-energised) if there is a power failure, broken cable or internal inverter fault. The relay energises again as soon the cause has been eliminated and power RESET has been performed.

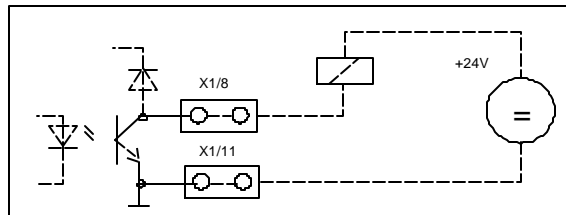

internal free-wheel diode

Frequency contact, X1/9, <S2OUT>

This output becomes active (relay closes) when the output frequency has exceeded the programmed value of the pre-set frequency FF5 (factory setting 3 Hz).

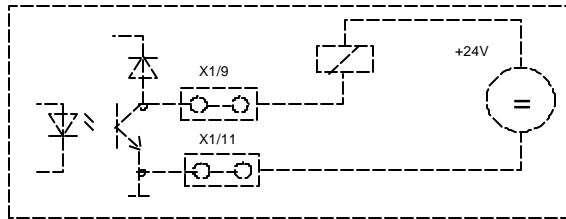

internal free-wheel diode

Programmable analog output, X1/10, <SOUTA>

SOUTA operates as an analog frequency output. It supplies a voltage signal proportional to the output frequency of the inverter.

Format

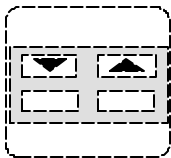

SOUT	Name	Fact. setting
10 V	FMAX	50 Hz
0.1 V	FMIN	0,5 Hz
0 V	STOP	0 Hz

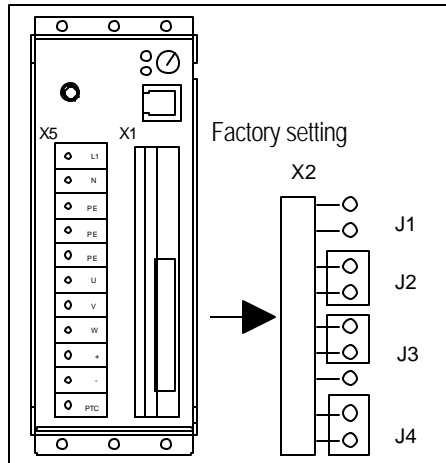

The selection of the input FSINA is made via the jumper strip X2, accessible after removing the terminal block X1.

- No jumper
- Jumper in place

Pos.	J3	J4	Function	Remarks	61-SOUTA
1	<input checked="" type="checkbox"/> <input type="checkbox"/> <input type="checkbox"/>	<input type="checkbox"/> <input type="checkbox"/>	No function		
2	<input checked="" type="checkbox"/> <input checked="" type="checkbox"/> <input type="checkbox"/>	<input checked="" type="checkbox"/> <input checked="" type="checkbox"/>	Output 0 ... 10 V	Factory setting	1
3	<input type="checkbox"/> <input checked="" type="checkbox"/> <input checked="" type="checkbox"/>	<input type="checkbox"/> <input type="checkbox"/>	Pulsed output	Signal PWM	1
4	<input type="checkbox"/> <input checked="" type="checkbox"/> <input checked="" type="checkbox"/>	<input type="checkbox"/> <input type="checkbox"/>	Pulsed output	BC pulses	3, 2
5	<input type="checkbox"/> <input checked="" type="checkbox"/> <input checked="" type="checkbox"/>	<input checked="" type="checkbox"/> <input checked="" type="checkbox"/>	No function		

BC = braking chopper

SOUTA as pulsed output

When the jumpers J3 and J4 are placed in pos. 3, this output delivers a PWM signal as follows:









Output frequency = 0 Hz ? 0 % PWM
 Output frequency = FMAX ? 100 % PWM

When the jumpers J3 and J4 are placed in pos. 4, this output delivers a PWM signal as follows:

61-SOUTA = 3 ? 6 times the output frequency, mark/space ratio 1:1
 61-SOUTA = 2 ? Signal "1" (high), brake chopper active

3. Monitoring and Fault Diagnostics

3.1 Operating display

H1 (red)	H2 (green)	Meaning
		Inverter out of operation
		Power supply is switched on. After 0.5 s self-test the inverter is ready
		Inverter in START
		Overload protection is active

3.2 Overload protection (I x t monitoring)







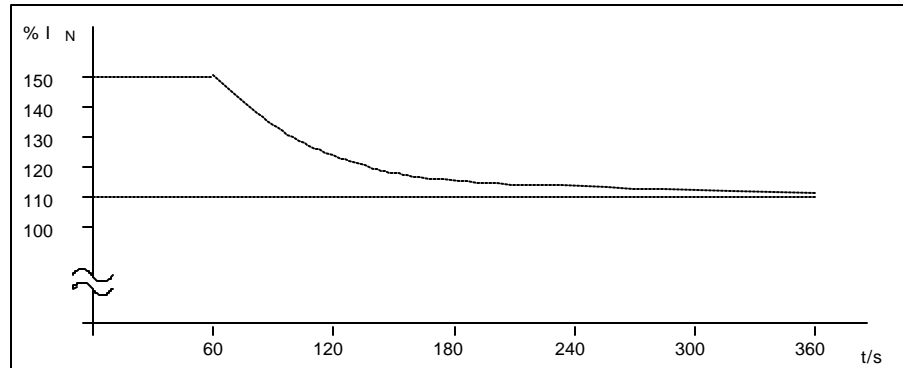

The I x t monitoring protects the power transistors from thermal overload. The maximum permissible overload area may be read from the graph.

Rule of Thumb :

The maximum permissible overload is, 150% of I_N lasting for 1 min every 10 mins.

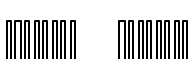

3.3 Fault messages

	H1 (red) flickers	Cause	Correction, Comments
	1 time	Microprocessor error	Turn the inverter OFF and ON again. (Turn ON RESET)
	2 times	Interruption of power supply Power supply voltage too low	Flickers until the intermediate voltage $U_{ZK} < 65$ V. Auto-RESET active
	3 times	Over current detection $I_N > 180\% I_N$, short-circuit	Check motor and motor wiring
	4 times	Over voltage or motor regenerating	Check power supply Check driven system
	5 times	Ixt protection of the motor	Motor overloaded Check driven system
	6 times	Ixt protection of the inverter	Inverter overloaded Check driven system
	7 times	Motor temperature too high	Check bridge X5/10-11 Motor overloaded
	8 times	Inverter temperature too high	Inverter overloaded. Check driven system and unit cooling
	9 times	EEPROM error	Turn the inverter OFF and ON again. (Turn ON RESET)

Assistance:

Should you have problems during installation or start up of the AC drive our technical staff are available for assistance. Please contact your local supplier or the factory