



www.DanaherMotion.com

*Installation Instructions for SLO-SYN[®]
SS2000D3 AND SS2000D6 Packaged Drives*

400030-024 Rev K



Record of Manual Revisions

ISSUE	Date	Description of Revision
K	09/12/2003	Updated corporate information

Copyright Information

© Copyright 1992 - 2003 Danaher Motion - All rights reserved.
Printed in the United States of America.

NOTICE:

Not for use or disclosure outside of Danaher Motion except under written agreement. All rights are reserved. No part of this book shall be reproduced, stored in retrieval form, or transmitted by any means, electronic, mechanical, photocopying, recording, or otherwise without the written permission from the publisher. While every precaution has been taken in the preparation of the book, the publisher assumes no responsibility for errors or omissions. Neither is any liability assumed for damages resulting from the use of the information contained herein.

This document is proprietary information of Danaher Motion that is furnished for customer use ONLY. No other uses are authorized without written permission of Danaher Motion. Information in this document is subject to change without notice and does not represent a commitment on the part of Danaher Motion. Therefore, information contained in this manual may be updated from time-to-time due to product improvements, etc., and may not conform in every respect to former issues.

Safety

Safety symbols used in this manual are:



Warning Alerts users to potential physical danger or harm. Failure to follow warning notices could result in personal injury or death.



Caution Directs attention to general precautions, which if not followed, could result in personal injury and/or equipment damage.



Note Highlights information critical to your understanding or use of the product.

Instructions

Only qualified personnel should install or perform servicing procedures on this equipment. *Do not* operate the unit without the enclosures in place as voltage present in this unit can cause serious or fatal injury.

Before performing any work on the unit, allow at least five minutes for the capacitors to discharge fully.

Voltage is present on unprotected pins when unit is operational.

The "PWR ON" LED must be off for approximately 30 seconds before making or breaking the motor connections.

Motors powered by these drives may develop extremely high torque. Disconnect AC power to these drive before doing any mechanical work.



This unit is designed for 115 VAC input only (see Section 4.2, Electrical Specifications).

Warranty And Limitation Of Liability

Danaher Motion (the "Company") warrants to the first end user purchaser (the "purchaser") of equipment manufactured by the Company that such equipment, if new, unused and in original unopened cartons at the time of purchase, is free from defects in material and workmanship under normal use and service for a period of one year from date of shipment from the Company's factory or a warehouse of the Company in the event that the equipment is purchased from the Company or for a period of one year from the date of shipment from the business establishment of an authorized distributor of the Company in the event that the equipment is purchased from an authorized distributor.

THE COMPANY'S OBLIGATION UNDER THIS WARRANTY SHALL BE STRICTLY AND EXCLUSIVELY LIMITED TO REPAIRING OR REPLACING, AT THE FACTORY OR A SERVICE CENTER OF THE COMPANY, ANY SUCH EQUIPMENT OR PARTS THEREOF WHICH AN AUTHORIZED REPRESENTATIVE OF THE COMPANY FINDS TO BE DEFECTIVE IN MATERIAL OR WORKMANSHIP UNDER NORMAL USE AND SERVICE WITHIN SUCH PERIOD OF ONE YEAR. THE COMPANY RESERVES THE RIGHT TO SATISFY SUCH OBLIGATION IN FULL BY REFUNDING THE FULL PURCHASE PRICE OF ANY SUCH DEFECTIVE EQUIPMENT. This warranty does not apply to any equipment which has been tampered with or altered in any way, improperly installed or has been subject to misuse, neglect or accident.

THE FOREGOING WARRANTY IS IN LIEU OF ANY OTHER WARRANTIES, EXPRESS OR IMPLIED, INCLUDING, WITHOUT LIMITATION, ANY IMPLIED WARRANTY OF MERCHANTABILITY OR FITNESS FOR A PARTICULAR PURPOSE, and of any other obligations or liabilities on the part of the Company; and no person is authorized to assume for the Company any other liability with respect to equipment manufactured by the Company. The Company shall have no liability with respect to equipment not of its manufacture. **THE COMPANY SHALL HAVE NO LIABILITY WHATSOEVER IN ANY EVENT FOR PAYMENT OF ANY INCIDENTAL OR CONSEQUENTIAL DAMAGES, INCLUDING, WITHOUT LIMITATION, DAMAGES FOR INJURY TO ANY PERSON OR PROPERTY.**

Written authorization to return any equipment or parts thereof must be obtained from the Company. The Company shall not be responsible for any transportation charges.

IF FOR ANY REASON ANY OF THE FOREGOING PROVISIONS SHALL BE INEFFECTIVE, THE COMPANY'S LIABILITY FOR DAMAGES ARISING OUT OF ITS MANUFACTURE OR SALE OF EQUIPMENT, OR USE THEREOF, WHETHER SUCH LIABILITY IS BASED ON WARRANTY, CONTRACT, NEGLIGENCE, STRICT LIABILITY IN TORT OR OTHERWISE, SHALL NOT IN ANY EVENT EXCEED THE FULL PURCHASE PRICE OF SUCH EQUIPMENT.

Any action against the Company based upon any liability or obligation arising hereunder or under any law applicable to the sale of equipment, or the use thereof, must be commenced within one year after the cause of such action arises.

The right to make engineering refinements on all products is reserved. Dimensions and other details are subject to change.

Table of Contents

SECTION 1: INTRODUCTION	1
1.1 USING THIS MANUAL.....	1
1.2 PRODUCT FEATURES.....	1
SECTION 2: EXPRESS START UP.....	2
SECTION 3: INSTALLATION GUIDELINES.....	3
3.1 GENERAL WIRING GUIDELINES	3
3.2 MOUNTING	4
3.3 CONNECTOR LOCATIONS AND PIN ASSIGNMENTS.....	6
3.3.1 MOTOR CONNECTIONS.....	7
3.3.2 POWER INPUT.....	8
SECTION 4: SPECIFICATIONS	9
4.1 MECHANICAL	9
4.2 ELECTRICAL.....	9
4.3 ENVIRONMENTAL.....	9
4.4 MOTOR COMPATIBILITY	10
4.5 CURRENT SETTINGS.....	11
4.6 STEP RESOLUTION	11
4.7 SIGNAL SPECIFICATIONS	12
4.7.1 CONNECTOR PIN ASSIGNMENTS.....	12
4.7.2 SIGNAL DESCRIPTIONS.....	12
4.7.3 LEVEL REQUIREMENTS.....	13
4.7.4 TIMING REQUIREMENTS	13
4.8 INDICATOR LIGHTS.....	14
4.9 TEST.....	14

SECTION 5: TORQUE VERSUS SPEED CHARACTERISTICS 15

5.1 MOTOR PERFORMANCE 15

5.2 TYPICAL TORQUE VERSUS SPEED CURVES..... 16

SECTION 6: SYSTEM CHECKING..... 23

APPENDIX A: TROUBLESHOOTING..... 25

A.1 ELECTRICAL INTERFERENCE PROBLEMS..... 25

A.2 CUSTOMER SUPPORT..... 26

SECTION 1: INTRODUCTION

1.1 USING THIS MANUAL

It is important that you understand how this SLO-SYN[®] 2000 unit is installed and operated before you attempt to use it. **Read this manual completely before proceeding with the installation of this unit.**

This manual is an installation and operating guide to the SLO-SYN 2000 Drive. Section 1 gives an overview of the Drive and its features. Section 2 describes the steps necessary to place the drive into operation. General wiring guidelines as well as the physical mounting of the unit and connections to the drive portion are covered in Section 3.

Complete specifications, listed in Section 4, provide electrical, mechanical and performance specifications. The procedure for setting the motor current level is also covered in this section.

Torque versus speed characteristics with all appropriate SLO-SYN Stepper Motors are given in Section 5. Section 6, System Checking, gives procedures to follow if the SLO-SYN 2000 drive fails to operate properly.

Appendix A provides procedures for troubleshooting electrical interference problems.

1.2 PRODUCT FEATURES

SLO-SYN 2000 drives are bipolar, speed adjustable, two-phase chopper drives which use power MOSFET and IGBT devices. They can be set to operate a stepper motor in full or half steps or in 1/5, 1/10, 1/16, 1/36, 1/50, 1/100, 1/125 or 1/250 microsteps. The maximum running speed is 10,000 full steps per second. To reduce the chances of electrical noise problems, the control signals are optically isolated from the drive circuit.

- U.L. Recognized under Component Program, File #E146240

- Switch selectable current levels of .05 through 6 amperes depending on unit selected.

- Latched short circuit protection (phase-to-phase and phase-to-ground)

- Unlatched undervoltage and transient overvoltage protection

- Inputs are optically isolated

- Boost/Reduce Current and Windings Off capabilities

- Drive Ready output

- Built-in AC line filter plus MOV

- Self-test function

- Boost Current

- Reduce Current

SECTION 2: EXPRESS START UP

The following instructions define the minimum steps necessary to make your **Drive** operational.



Always disconnect the AC power to the unit and be certain the "PWR ON" LED is OFF before connecting or disconnecting the motor leads. FAILURE TO DO THIS RESULTS IN A SHOCK HAZARD.

Always operate the Motor and the Drive GROUNDED. Be sure to twist together the wires for each motor phase. Six twists per foot is a good guideline.

1. Check to see that the motor used is compatible with the drive. Refer to Section 4.4 for a list of compatible motors.
2. Set the correct current level for the motor being used per the instructions in Section 4.5.
3. Select the appropriate step resolution and set the front panel switches as described in Section 4.6.
4. Wire the motor per the "Motor Connections" description in Section 3.3.
5. Connect the power source to the AC input terminal strip. The terminal labeled "L1" is line or hot, "N" is neutral or common and " \ominus " is ground.



If the motor operates erratically, refer to Section 5, "Torque Versus Speed Characteristics". Clockwise and counter-clockwise directions are properly oriented when viewing the motor from the end opposite the mounting flange.

Section 3: Installation Guidelines

3.1 GENERAL WIRING GUIDELINES

SLO-SYN 2000 drives use modern solid-state electronics to provide the features needed for advanced motion control applications. In some cases, these applications produce electromagnetic interference (EMI, or electrical "noise") that cause inappropriate operation of the digital logic used in the drive, or in any other computer-type equipment in the user's system.

In general, any equipment that causes arcs or sparks or that switches voltage or current at high frequencies can cause interference. In addition, AC utility lines are often "polluted" with electrical noise from sources outside a user's control (such as equipment in the factory next door). Some of the more common causes of electrical interference are:

- Power from the utility AC line
- Relays, contactors and solenoids
- Light dimmers
- Arc welders
- Motors and motor starters
- Induction heaters
- Radio controls or transmitters
- Switch-mode power supplies
- Computer-based equipment
- High frequency lighting equipment
- DC servo and stepper motors and drives

Use the following wiring practices to reduce noise interference.

Solid grounding of the system is essential. Be sure that there is a solid connection to the AC system earth ground. Bond the drive case to the system enclosure. Use a single-point grounding system for all related components of a system (a "hub and spokes" arrangement). Keep the ground connection short and direct.

Keep signal and power wiring well separated. If possible, use separate conduit or ducts for each. If the wires must cross, they should do so at right angles to minimize coupling.



Power wiring includes AC wiring, motor wiring, etc. and signal wiring includes inputs and outputs (I/O), serial communications (RS232 lines), etc.

Use shielded, twisted-pair cables for Indexer I/O lines. BE SURE TO GROUND SHIELDS ONLY AT ONE END, THE INDEXER/DRIVE END FOR OUTPUTS AND THE SWITCH OR SENSOR END FOR INPUTS.

Suppress all relays to prevent noise generation. Typical suppressors are capacitors or MOVs. (See manufacturers' literature for complete information). Whenever possible, use solid-state relays instead of mechanical contact types to minimize noise generation.

If you are experiencing problems with drive operation that might be related to EMI, refer to Appendix A for Troubleshooting pointers.

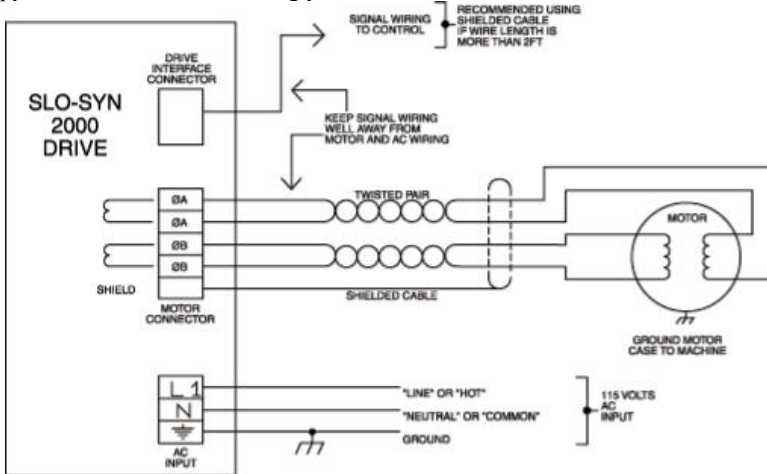

Figure 3.1 Recommended Wiring Practices

3.2 MOUNTING

The SLO-SYN Drive is mounted by fastening its mounting brackets to a flat surface as shown in Figures 3.2 and 3.3.

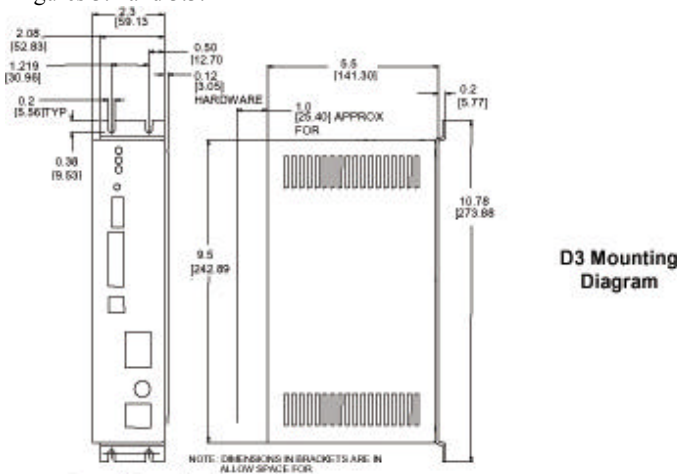

Figure 3.2 D3 Mounting Diagram

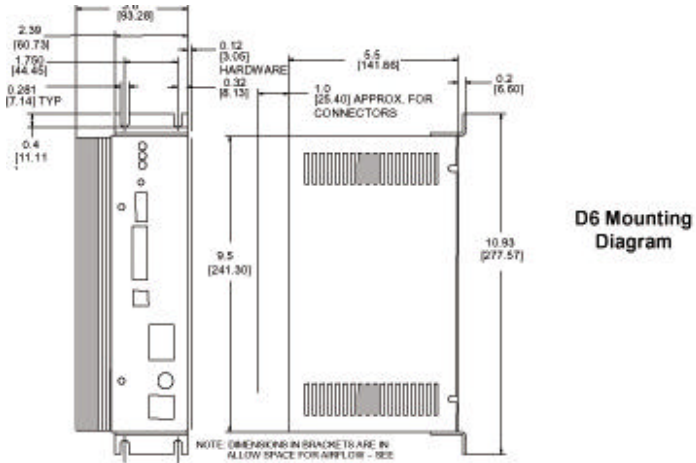

Figure 3.3 D6 Mounting Diagram



The unit should be mounted upright (with the cooling fins vertical) , or proper cooling will not occur. Air flow should not be obstructed. Case temperature should not exceed +70° C (+158° F). Forced air cooling may be required to maintain temperature within the stated limits.

When selecting a mounting location, it is important to leave at least two inches (51mm) of space around the top, bottom and sides of the unit to allow proper airflow for cooling.

It is also important to keep the drive away from obvious noise sources. If possible, locate the drive in its own metal enclosure to shield it and its wiring from electrical noise sources. If this cannot be done, keep the drive at least three feet from any noise sources.

3.3 CONNECTOR LOCATIONS AND PIN ASSIGNMENTS

Figure 3.4 shows the connector locations for the SLO-SYN 2000 drive.

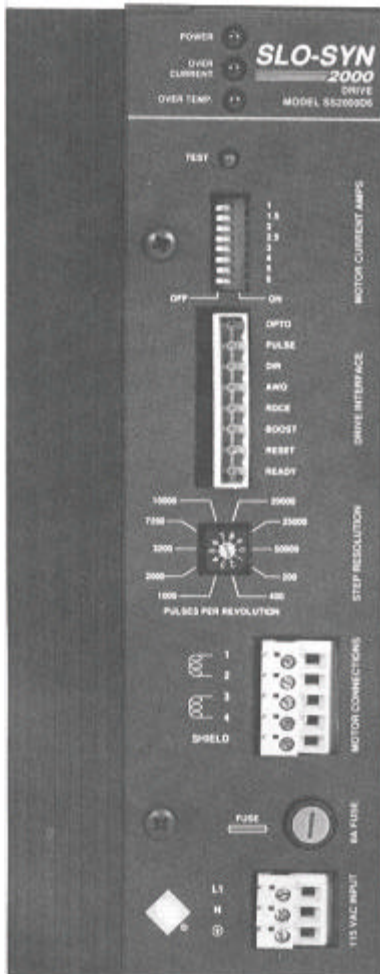

Figure 3.4 Connector Locations

3.3.1 Motor Connections

All motor connections are made via the 5-pin connector. Pin assignments for this connector are:

Motor Connection			
Pin	Assignment	Leads	Terminals
1	M1 (Phase A)	Red	#1
2	M3 (Phase A)	White/Red	#3
3	M4 (Phase B)	Black	#4
4	M5 (Phase B)	White/Blk	#5
5	Shield	Shield	-



Motor phase A is M1 and M3 and motor phase B is M4 and M5. The motor frame must be grounded.

Cabling from the drive to the motor should be done with a shielded, twisted pair cable. As a guideline, the wires for each motor phase should be twisted about six times per foot.

Danaher Motion offers the following motor cable configurations. These cables have unterminated leads on both ends.

Length	Part Number
10 ft (3 m)	216022-031
25 ft (7.6 m)	216022-032
50 ft (15.2 m)	216022-033
75 ft (22.8 m)	216022-034

Figure 3.5 shows the possible motor wiring configurations.

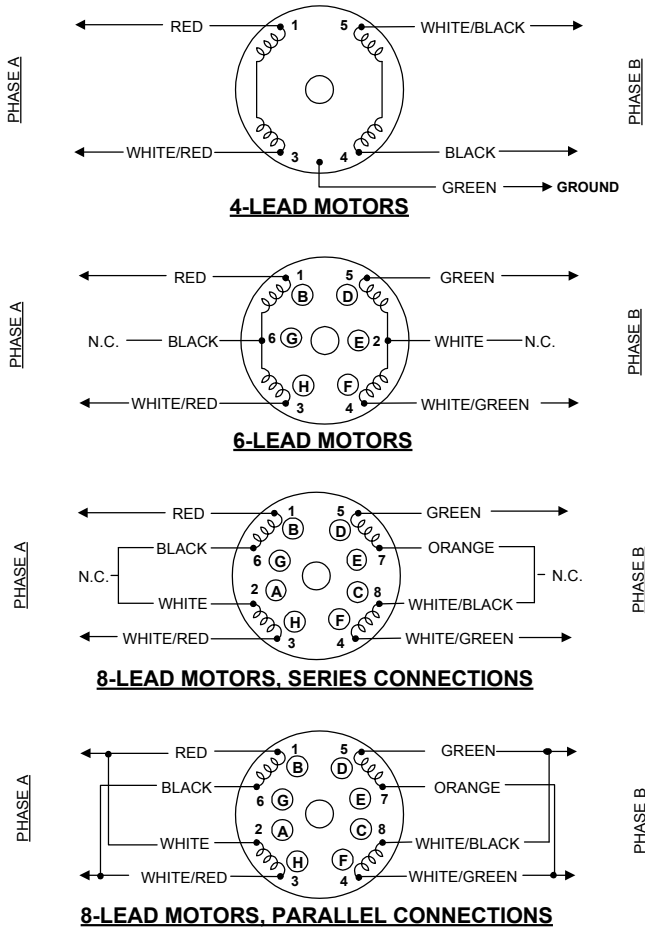

Figure 3.5 Motor Wiring Configurations

3.3.2 Power Input

The AC input power is connected to a 3-screw terminal strip. The terminals are:

Terminal	Lead Color, North American Standard
"L1 for Line or "Hot"	Black
"N" for Common or Neutral	White
"⊕" for Ground	Green

SECTION 4: SPECIFICATIONS

4.1 MECHANICAL

SS2000D3

Size

(Inches) 2.5W x 5.6 (5.8*)D x 9.6 (10.8*)H
(mm) 63W x 142 (147*)D x 244 (274*)H

Weight

3.2 pounds (1.45 kg)

* Includes mounting hardware

SS2000D6

Size

(Inches) 3.8W x 5.6 (5.85*)D x 9.5* (10.75*)H
(mm) 97 W x 142 (149*) D x 241 (273*) H

Weight

6.5 pounds (2.95 kg)

* Includes mounting hardware

4.2 ELECTRICAL

AC Input Range 90 to 132 VAC, 50/60 Hz

AC Current D3 – 5 amperes

D6 – 7 amperes

Fuse Rating** 250 volts, 8 amperes

Fuse Type** Littelfuse part number 314008 or Bussman part number ABC-8

Drive Power Dissipation

(Worse Case)D3 – 35 watts

D6 – 50 watts

** If this fuse blows, the power supply is prevented from energizing any of its outputs, hence, the unit will not operate. Usually, this fuse only blows if an internal failure occurs.

4.3 ENVIRONMENTAL

Temperature

Operating

+32° F to +122° F

(0° C to +50° C) free air ambient, Natural Convection

Storage

-40° F to +167° F

(-40° C to +75° C)

Humidity

95% max. non-condensing

Altitude

10,000 feet (3048 m) max.

Pollution Degree

Level 2

4.4 MOTOR COMPATIBILITY

Motor Types	Superior Electric KM and M Series
Frame Sizes	D3: KML060 — KML091 M061 — M092
	D6: KML060 — KML093 M061 — MH112



Do Not use larger frame size motor than those listed, or the drive may be damaged.

Number of Connections	4, 6, 8
Minimum Inductance	8 millihenrys
Maximum Inductance	64 millihenrys
Maximum Resistance	2 ohms at 6 amp. setting



Maximum resistance is total of motor plus cable.

MOTORS FOR USE WITH THE SS2000D3/D6 DRIVE

Motor	Current (amperes)	D3	D6
KML060-F02	1.5	X	X
KML061-F03	1.5	X	X
KML062-F03	1.5	X	X
KML063-F04	2	X	X
KML091-F05	3	X	X
KML091-F07	3	X	X
KML092-F07	4		X
KML093-F08	4		X
KML093-F10	6		X
M061-FF206	1	X	X
M062-FF206	1.5	X	X
M063-FF206	1.5	X	X
M091-FF206	3	X	X
M092-FF206	4		X
M093-FF206	4		X
M111-FF206	5		X
M112-FF206	6		X
MH112-FF206	6		X



Duty cycle limiting or external motor cooling may be required to keep the shell temperature below its rating.

4.5 CURRENT SETTINGS

The proper current setting for each motor is shown on the individual torque vs. speed curves. Use this current level to obtain the torque shown. The access hole for the switches which set the motor current level is located on the front of the unit (see Figure 4.1). Select the desired operating current by setting the appropriate switch to the "ON" position. Only one switch should be ON. If two or more switches are ON, the one that selects the highest current level is the active switch. The switch settings are:

Position	D3 Current (amperes)	D6 Current (amperes)
8	0.5	1.0
7	0.75	1.5
6	1.0	2.0
5	1.25	2.5
4	1.5	3.0
3	2.0	4.0
2	2.5	5.0
1	3.0	6.0

4.6 STEP RESOLUTION

The number of pulses per revolution is selected using the rotary switch on the front panel. The arrow on the switch knob can point to any of ten positions. The following chart shows the number of pulses per revolution selected by each switch position.

Switch Position	Pulses Per Revolution
1	200
2	400
3	1,000
4	2,000
5	3,200
6	7,200
7	10,000
8	20,000
9	25,000
0	50,000

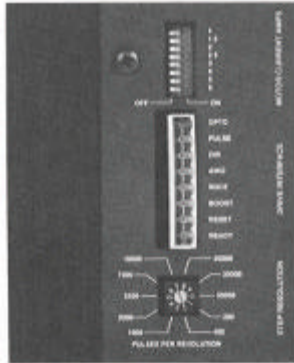

Figure 4.1 Switches For Setting Current Level and Step Resolution

4.7 SIGNAL SPECIFICATIONS

4.7.1 Connector Pin Assignments

All connections are made via the 8-pin connector, part number 220878-008.

Pin	Assignment
1	OPTO
2	PULSE
3	DIR
4	AWO
5	RDCE
6	BOOST
7	RESET
8	READY

4.7.2 Signal Descriptions

OPTO Opto-Isolator Supply
User supplied power for the opto-isolators.

PULSE Pulse Input
A low to high transition on this pin advances the motor one step. The step size is determined by the Step Resolution switch setting.

DIR Direction Input
When this signal is high, motor rotation is clockwise. Motor rotation is counter-clockwise when this signal is low.
Clockwise and counter-clockwise directions are properly oriented when viewing the motor from the end opposite the mounting flange.

- AWO** All Windings Off Input
When this signal is low, AC and DC current to the motor will be zero. **There is no holding torque when the AWO signal is low.**
- RDCE** Reduce Current Input
The motor current is 50% of the selected value when this signal is low. **Holding torque is also reduced when this signal is low.**
- BOOST** Boost Current Input
When this signal is low, the motor current is 150% of the selected level up to a maximum of 6 amperes.
- RESET** Reset Input
The translator goes to the "power up" state when this signal goes low.
- READY** Ready Output
This pin is the emitter of an opto-isolator that activates when the drive is ready to run a motor.

4.7.3 Level Requirements

OPTO

- Voltage 4.5 to 6.0 VDC
Current 20 mA per signal used

READY

- Voltage 4.5 to 6.0 VDC (depends on OPTO)
Current 0.5 mA source

Other Signals

- Voltage
Low..... ≤ 0.8 VDC
 ≥ 0.0 VDC
High..... \leq OPTO
 \geq OPTO - 1 volt
- Current
Low..... ≤ 20 mA
High..... ≤ 0.2 mA

4.7.4 Timing Requirements

PULSE

- Max. Frequency..... 1 megahertz
Max. Rise and
Fall Times..... 1 microsecond
Min. Pulse
Width..... 0.4 microseconds

Other Signals

- Response Time ≤ 50 microseconds

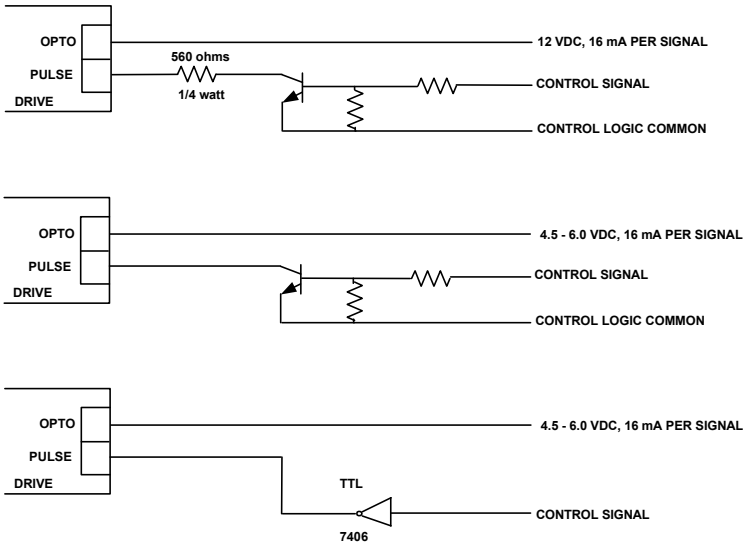

Figure 4.2 Suggested Methods For Control Interface

4.8 INDICATOR LIGHTS

"POWER" LED, Red

Lights when the drive logic power supply is present, indicating the drive is energized.

"OVERCURRENT" LED, Red

Lights to indicate over-current condition. This condition is a result of motor wiring errors or a ground fault. Recovery from this condition requires removing AC power, correcting the problem, then re-energizing AC power.

"OVER TEMP" LED, Red

Lights to indicate the air temperature inside the drive has exceeded a safe level for reliable operation. Recovery from this condition requires removing and reapplying the AC power.

4.9 TEST

A pushbutton Test switch is located on the front panel. To operate the Test function, disconnect the translator input connector and actuate the switch. If the drive and motor are wired correctly, the motor rotates clockwise at about 1/2 revolution per second.

SECTION 5: TORQUE VERSUS SPEED CHARACTERISTICS

5.1 MOTOR PERFORMANCE

All stepper motors exhibit instability at their natural frequency and harmonics of that frequency. Typically, this instability occurs at speeds between 50 and 500 full steps per second and, depending on the dynamic motor load parameters, cause excessive velocity modulation or improper positioning. This type of instability is represented by the open area at the low end of each Torque vs. Speed curve.

There are also other instabilities that cause a loss of torque at stepping rates outside the range of natural resonance frequencies. One such instability is broadly defined as mid-range instability. Usually, the damping of the system and acceleration/deceleration through the resonance areas aid in reducing instability to a level that provides smooth shaft velocity and accurate positioning. If instability does cause unacceptable performance under actual operating conditions, use the following techniques to reduce velocity modulation.

- 1) Avoid constant speed operation at the motors unstable frequencies. Select a base speed above the motors resonant frequencies and adjust acceleration and deceleration to move the motor through unstable regions quickly.
- 2) The motor winding current can be reduced as discussed in Section 4.5. Lowering the current reduces torque proportionally. The reduced energy delivered to the motor can decrease velocity modulation.
- 3) Use the half-step mode of operation or use microstepping to provide smoother operation and reduce the effects of mid range instability. **Microstepping reduces the shaft speed for a given pulse input rate.**

5.2 TYPICAL TORQUE VERSUS SPEED CURVES

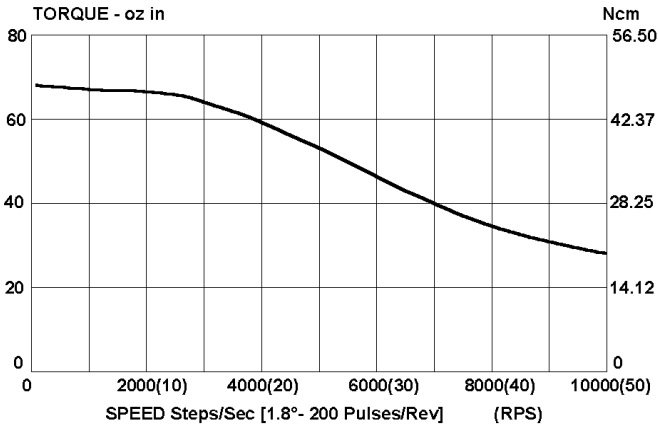

KML060-F02 MOTOR, 1.5 AMPERES

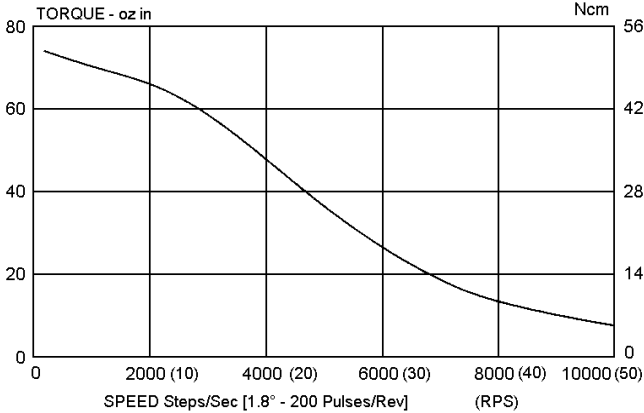

M061-FF206 MOTOR, 1.0 AMPERES



KML061-F03 MOTOR, 1.5 AMPERES

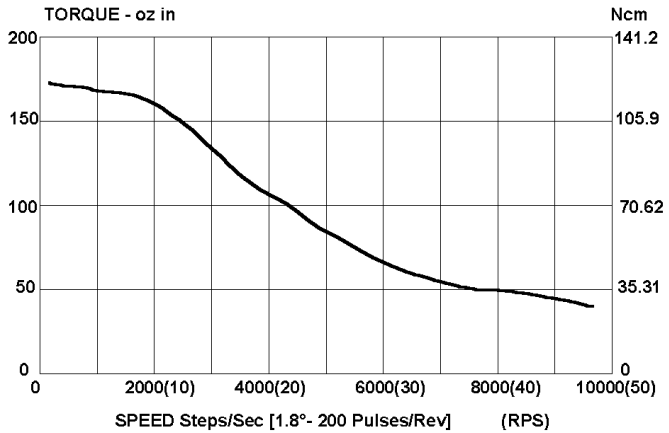

KML062-F03 MOTOR, 1.5 AMPERES

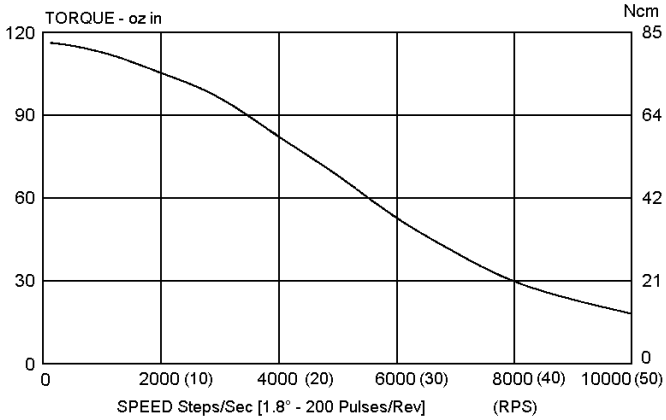

M062-FF206 MOTOR, 1.5 AMPERES

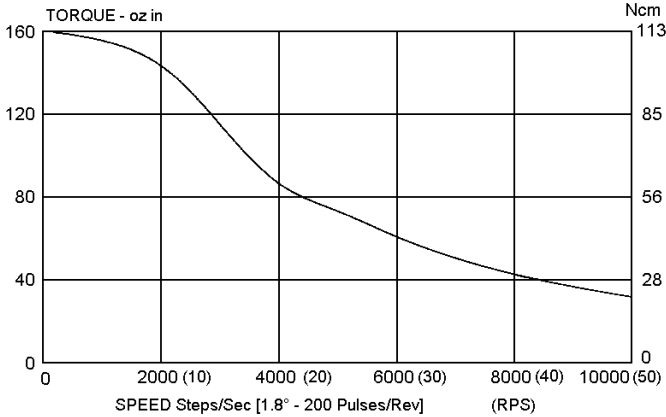

M063-FF206 MOTOR, 1.5 AMPERES

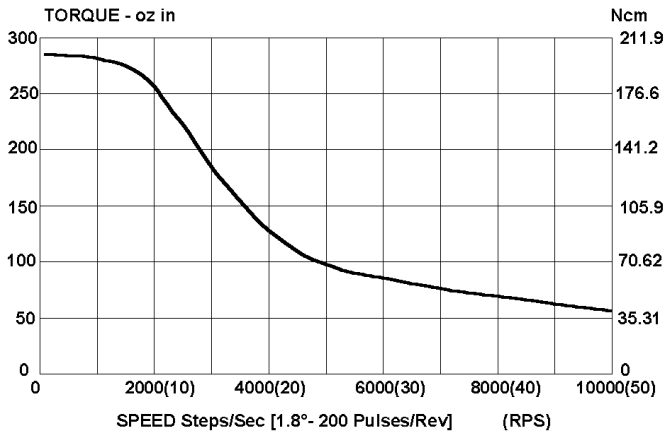

KML063-F04 MOTOR, 2.0 AMPERES

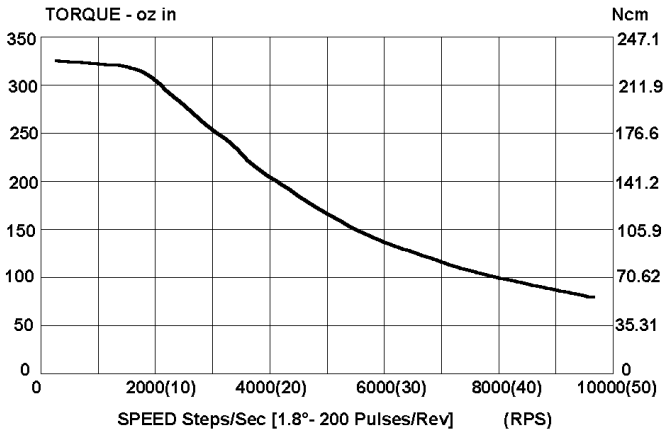

KML091-F05 MOTOR, 3.0 AMPERES

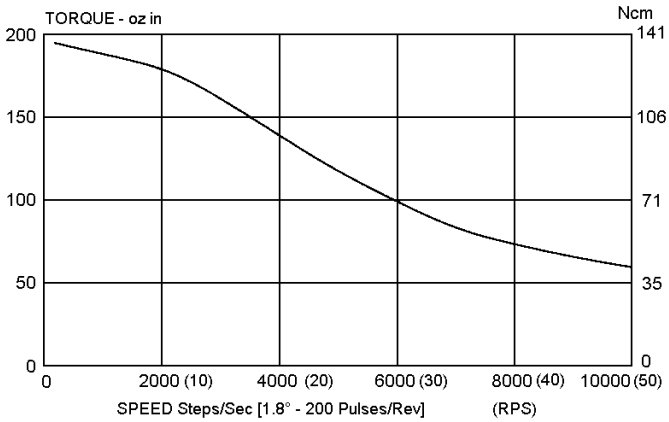

M091-FF206 MOTOR, 3.0 AMPERES

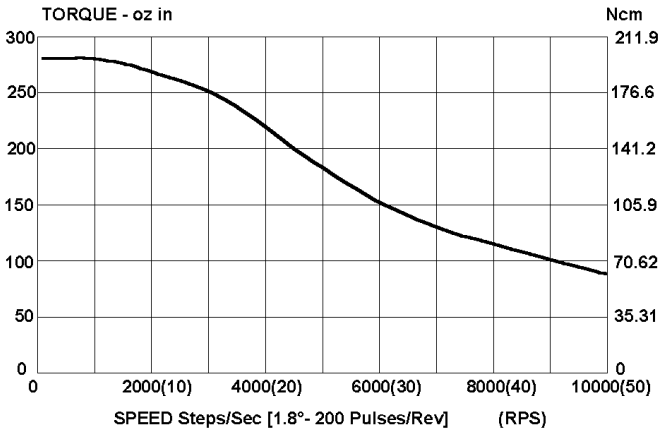

KML091-F07 MOTOR, 3.0 AMPERES

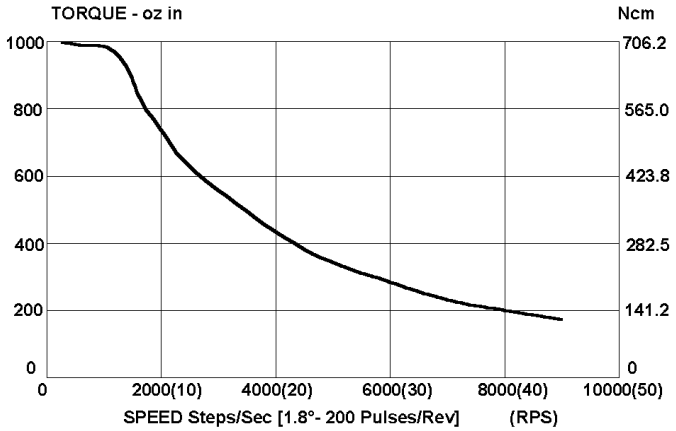

KML093-F10 MOTOR, 6.0 AMPERES

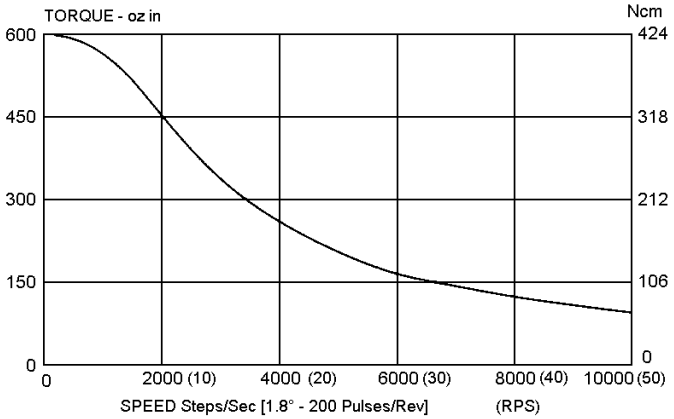

M111-FF206 MOTOR, 5.0 AMPERES

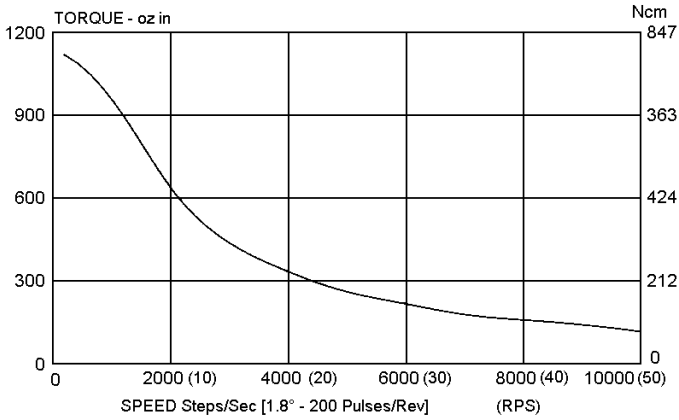

M112-FF206 MOTOR, 6.0 AMPERES

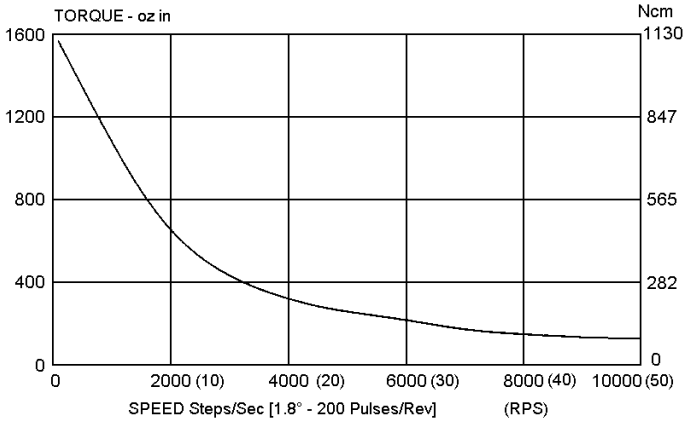

MH112-FF206 MOTOR, 6.0 AMPERES

SECTION 6: SYSTEM CHECKING



Motors connected to this drive can develop high torque and large amounts of mechanical energy.

Keep clear of the motor shaft and all parts mechanically linked to the motor shaft.

Turn off all power to the drive before performing work on parts mechanically coupled to the motor.

If installation and operating instructions have been carefully followed, this unit should perform correctly. If the motor fails to step properly, the following checklist will be helpful in locating and correcting the problem.

In General

Check all installation wiring carefully for wiring errors or poor connections.

Check to see that the proper voltage levels are being supplied to the unit. Be sure that the "POWER" LED lights when AC power is applied.

Be sure that the motor is a correct model for use with this unit.

Disconnect the control interface connector. With the motor connected and AC power applied to the drive, push the front panel "Test" switch. The motor should rotate at about 1/2 rev. per second. If it does rotate, the motor, drive, AC input and associated wiring are probably OK. The problem is most likely in either the pulse source or control wiring to the drive.

If the motor *does not* turn, there is a problem with the drive, motor, AC input or associated wiring.

Specifically

IF MOTOR DIRECTION (CW, CCW) IS REVERSED, Check For:

Reversed connections to the Motor Connector. Reversing the phase A *or* the phase B connections reverses the direction of motor rotation.

IF THE MOTOR MOTION IS ERRATIC, Check For:

Supply voltage out of tolerance.

Proper motion parameters (low speed, acceleration/deceleration, jog speed, home speed and feed rate). Set parameters on controller supplying pulse input to drive.

IF TORQUE IS LOW, Check For:

All Windings Off active or Reduced Current active.

Improper supply voltage.

IF "POWER" INDICATOR IS NOT LIT, Check For:

- Improper AC input wiring and voltage levels
- Blown supply circuit fuse or tripped input circuit breaker
- Check for blown drive fuse

IF "OVERCURRENT" INDICATOR IS LIT, Check For:

- Improper motor wiring
- Grounded or shorted wiring to the motor or shorted motor
- Improper motor type or incorrect Current Select switch setting

IF THE "OVERTEMP" INDICATOR IS LIT, Check For:

- Ambient temperature around drive above 50° C (122° F)
 - Restricted airflow around drive
- If a malfunction occurs that cannot be corrected by making the preceding checks, contact Customer Support.

APPENDIX A: TROUBLESHOOTING

A.1 ELECTRICAL INTERFERENCE PROBLEMS

Electrical interference problems are common with today's computer-based controls. Such problems are often difficult to diagnose and cure. If such a problem occurs with your system, it is recommended that the following checks be made to locate the cause of the problem.

1. Check the quality of the AC line voltage using an oscilloscope and a line monitor. If line voltage problems exist, use appropriate line conditioning, such as line filters or isolation transformers.
2. Be certain all recommended wiring practices are followed for location, grounding, wiring and relay suppression (see Section 3.1).
3. Double-check the grounding connections to be sure they are good electrical connections and as short and direct as possible.
4. Try operating the drive with all suspected noise sources switched off. If the drive functions properly, switch the noise sources on again, one at a time, and try to isolate the one(s) causing the interference problems. When a noise source is located, try rerouting wiring, suppressing relays or other measures to eliminate the problem.

Mandatory connections to meet CE EMC requirements
 Vorgeschriebener Anschluss zur Übereinstimmung mit CE EMC Normen
 Branchement obligatoire afin de respecter la norme CE – EMC

1. SLO-SYN SS2000(V) + SS2000D3 or SS2000D6 + MOTOR

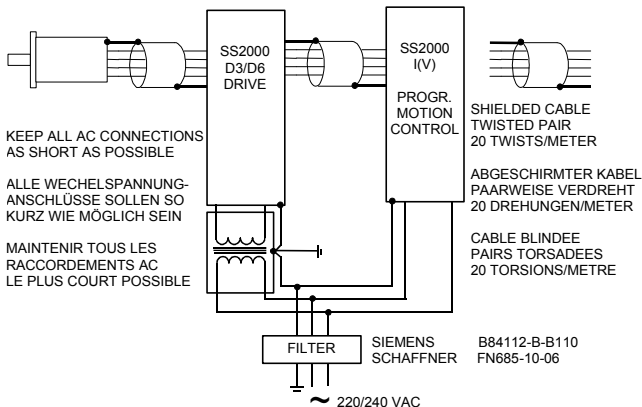

A.2 CUSTOMER SUPPORT

Danaher Motion products are available nationwide through an extensive authorized distributor network. These distributors offer literature, technical assistance and a wide range of models off the shelf for fastest possible delivery.

Danaher Motion sales engineers are conveniently located to provide prompt attention to customers' needs. Call the nearest office listed for ordering and application information or for the address of the closest authorized distributor.

In the US and Canada

13500-J South Point Blvd.
Charlotte, NC 28273

Phone: (704) 588-5693

Fax: (704) 588-5695

Email: sales2@danahermotion.com

Website: www.DanaherMotion.com

In Europe

Danaher Motion GmbH & Co. KG
Robert-Bosch-Straße 10
64331 Weiterstadt, Germany

Phone: +49 (0) 6151-8796-10

Fax: +49 (0) 6151-8796-123

Website: www.DanaherMotion.de