

PiC900 CONTROLS

MOTION SOLUTIONS PRODUCT GUIDE

Part Number M.1301.4204
Version 1.0

Giddings & Lewis

PiC900 Controls

NOTE

Progress is an ongoing commitment at Giddings & Lewis. We continually strive to offer the most advanced products in the industry; therefore, information in this document is subject to change without notice. The illustrations and specifications are not binding in detail. Giddings & Lewis shall not be liable for any technical or editorial omissions occurring in this document, nor for any consequential or incidental damages resulting from the use of this document.

DO NOT ATTEMPT to use any Giddings & Lewis product until the use of such product is completely understood. It is the responsibility of the user to make certain proper operation practices are understood. Giddings & Lewis products should be used only by qualified personnel and for the express purpose for which said products were designed.

Should information not covered in this document be required, contact the Customer Service Department, Giddings & Lewis, 660 South Military Road, P.O. Box 1658, Fond du Lac, WI 54936-1658. Giddings & Lewis can be reached by telephone at 920 921 7100.

Version 1.0

Copyright © 1999 - 2002 Giddings & Lewis, LLC

ARCnet is a trademark of Datapoint

Balluff is a trademark of Gerhard Balluff Febrick Feinmechanischer Erzeugnisse GMBH & Co.

Belden is a trademark of Cooper Industries, Inc.

Cimplicity is a trademark of GE FanucAutomation North America, Inc.

Cimrex is a trademark of Cimrex Electronic AB

Data Highway Plus is a trademark of Allen-Bradley Company

DeviceNet is a trademark of Iris Technologies, Inc.

IBM is a trademark of International Business Machines Corp.

IEEE is a trademark of the Institute of Electrical and Electronics Engineers

Inductosyn is a trademark of Ruhle Companies Inc., Farrand Optical Co., Inc.

Intellution is a trademark of Intellution, Inc.

Modbus is a trademark of Gould, Inc.

MODHUB is a trademark of CCSi

Modicon is a trademark of Modicon Corporation

NEMA is a trademark of the National Energy Manufacturers Association

OPC OLE for Process Control is a trademark of OPC Foundation

Pentium is a trademark of Intel Corporation

RSView is a trademark of Rockwell Software, Inc.

Temposonics is a trademark of MTS Systems Corporation

Windows 95, Windows 98, Windows NT, MS-DOS, QuickBASIC, and Microsoft are trademarks of Microsoft Corporation

Wonderware is a trademark of Wonderware Corporation

PiC900, PiC90, PiCPro, PiCServoPro, PiCMicroTerm, Centurion, and MMC are trademarks of Giddings & Lewis, LLC

Table of Contents:

PiC900 Controls Product Guide

Introduction.....	1
The PiC™ System.....	3
System Racks.....	5
PiC Family CSM/ RSM Modules	9
CSM Module/RSM Module.....	11
PiC90 RSM I/O Module	15
Specification Table	16
PiC Family CPU Modules	17
PiC94X CPU Module	19
Specification Table	20
PiC904X- CSM/CPU Central Service Module/Central Processing Unit	24
Specification Table	25
PiC 900 Communications Modules	29
Ethernet - TCP/IP Module	31
Specification Table	32
DeviceNet Module.....	34
Specification Table	35
Serial Communications Module (2, 4 channel)	36
Specification Table	37
I/O Expansion	39
Block I/O Expansion.....	41
PiC 900 Discrete I/O Modules.....	43
Input 24V DC Module (32 or 16 points)	45
Specification Table	46
Input 24V DC Module (16 switch).....	48
Specification Table	49
Input 12V DC Module (32 points).....	51
Specification Table	52
Input 120V AC Module (16 points).....	54
Specification Table	55
Output 24V DC Source Module (32 or 16 points).....	57
Specification Table	58
Output 24V DC Sink Module (3 versions).....	60
Specification Table	61
Output Relay Module (8 points).....	63
Specification Table	64
Output 120/240V AC Module (32 or 16 points).....	66
Specification Table	67
Input/Output TTL Module (24 inputs/8 outputs).....	69
Specification Table	70
Input/Output 24V DC Sink Module (16/8 points).....	72
Specification Table	73

Input/Output 24V DC Source Module (16/8 points)	75
Specification Table	76
PiC 900 Analog Modules	79
Analog Input Module (8 channel).....	81
Specification Table	82
Analog Output ±10V DC Module (8, 4 channel)	85
Specification Table	86
Analog Input ±10V Output (4 Channel).....	89
Specification Table	90
TEMP J-K Thermocouple Module (12 channel)	93
Specification Table	94
RTD Module (6 channel).....	97
Specification Table	98
Output 4-20mA Module (6 channel)	101
Specification Table	102
PiC Family Miscellaneous Modules	105
Barrier Module.....	107
PiC 900 Servo/Feedback Modules	109
Encoder Module (2, 4, High Speed 4 channel).....	111
Specification table.....	112
Resolver Module (4, 2 channel).....	115
Specification Table	116
Multi-Channel Resolver Module (12 channel)	119
Specification Table	120
Servo Encoder with Analog I/O Module	122
Specification Table	123
Servo Encoder with Analog Output Module	126
Specification Table	127
Slider Driver Module	130
Specification Table	131
Output Stepper Module (8 channel).....	132
Specification Table	133
Output Stepper Axis Module (8 channel).....	135
Specification Table	136
SERCOS Module for PiC	138
Specification Table	139
Specification Table for the Fiber Optic Cable	140
PiC 900 Options and Accessories	141
I/O Wiring Harness.....	143
Battery Backup Board.....	145

PiC900 CONTROLS
MOTION SOLUTIONS PRODUCT GUIDE

Introduction

Giddings & Lewis

The PiC™ System

The PiC is more than just a motion control. It's a *machine* control. The PiC combines motion, logic, and process control all in a single programming environment. Programmed with IEC1131 ladder logic and function block language using our powerful PiCPro for Windows software, the PiC provides a close coupled, integrated solution to the logic, motion, process, operator interface, and communications requirements found in today's industrial automation applications.

A PiC *system* consists of the components found in the following illustration. Motion control is accomplished through the use of encoder/resolver feedback modules and analog output modules, or by using the SERCOS module. The machine inputs and outputs (logic and process control) are handled with a wide variety of rack I/O or distributed block I/O modules. All I/O modules can be used across the PiC90 and PiC900 product lines interchangeably. Serial communications modules and application-specific software functions allow the PiC to communicate to a wide variety of operator interface devices.

PiCPro is the machine control software that ties it all together. Application programs developed for any PiC solution are 100% software compatible with one another. Motion, logic, operator interface, and process control are all performed in a single programming environment, simplifying development, maintenance, and troubleshooting of the application program.

Generally throughout this guide, the PiC refers to the PiC family of *Programmable industrial Computers* and includes the PiC90.

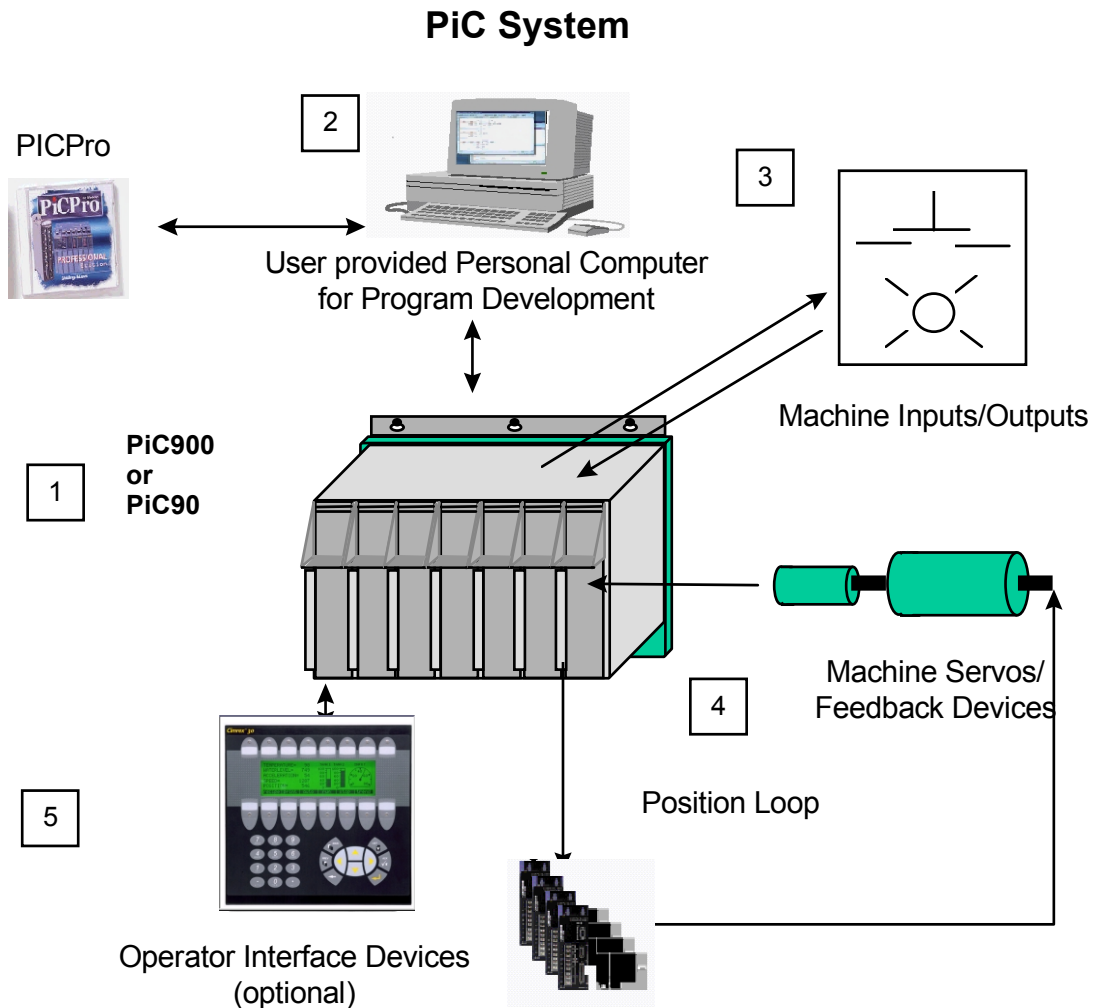

- 1 PiC900/90**
 The PiC900/90 is comprised of a system rack, a CSM module and a CPU module for the PiC900 or a CSM/CPU module for the PiC90, and I/O modules.

System rack - available in 7, 10, or 13 slots for the PiC900 and 3 or 5 slots for the PiC90.
- 2 PiCPro for Windows Software and Workstation**
 The software and computer which are used to develop application programs.
- 3 Machine Inputs/Outputs**
 The physical inputs to and outputs from the machine(s) that are controlled by the PiC.
- 4 Position Loop**
 The physical elements that provide closed loop control over axial positions - the feedback device(s) of the machines and the analog output module of the PiC.
- 5 Operator Interface Devices**
 A terminal, touch screen, or PC which can optionally be used by operators to interface with the system.

System Racks

The *system rack* has four functions:

1. It provides physical support for the top and bottom of each hardware module.
2. It passes power from the CSM (or CSM/CPU) to each of the other modules.
3. It contains a data bus, address bus and control lines. These lines allow data to pass between the CPU (or CSM/CPU) module and each of the other modules.
4. It has a 64-pin female connector at each slot position which allows communication between modules.

Dimensions of the racks

PiC system racks differ only in length and the number of hardware modules they can contain. A dimensional diagram of each rack is shown on the following pages.

System Racks

	Number of actual slots	Number of modules	Length	Height	Depth (with modules)	Part Number
PiC900	13	CSM, CPU, 11 I/O	21.6"	14.0"	9.0"	M.1017.1606 (old # 503-18011-03)
	10	CSM, CPU, 8 I/O	16.8"	14.0"	9.0"	M.1017.1600 (old # 503-18010-03)
	7	CSM, CPU, 5 I/O	12.0"	14.0"	9.0"	(M.1017.1594 (old # 503-18009-03)
PiC90	5*	CSM/CPU, 4 I/O	8.8"	14.0"	9.0"	M.1017.2284 (old # 503-19184-02)
	3*	CSM/CPU, 2 I/O	5.6"	14.0"	9.0"	M.1017.2288 (old # 503-19185-02)

*The PiC90 retaining bar labels the CSM/CPU module slot as 1/2, leaving 2 or 4 slots available for I/O modules.

In the illustrations that follow, racks with 3, 5, and 7 slots are shown with modules inserted. All racks are the same height and have the same profile. The next two rack sizes are shown empty.

System Racks with Modules Installed

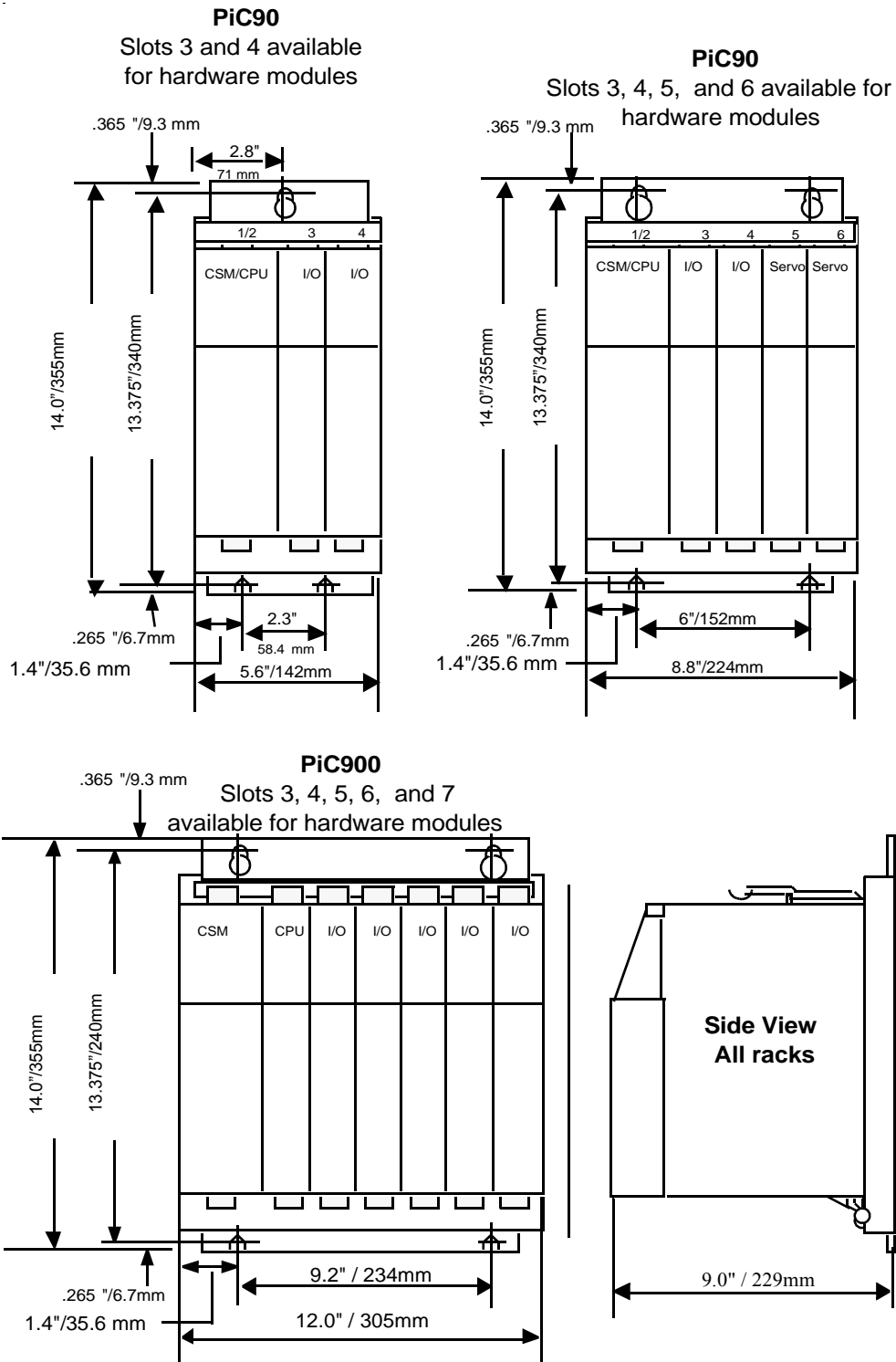

The 10-slot System Rack

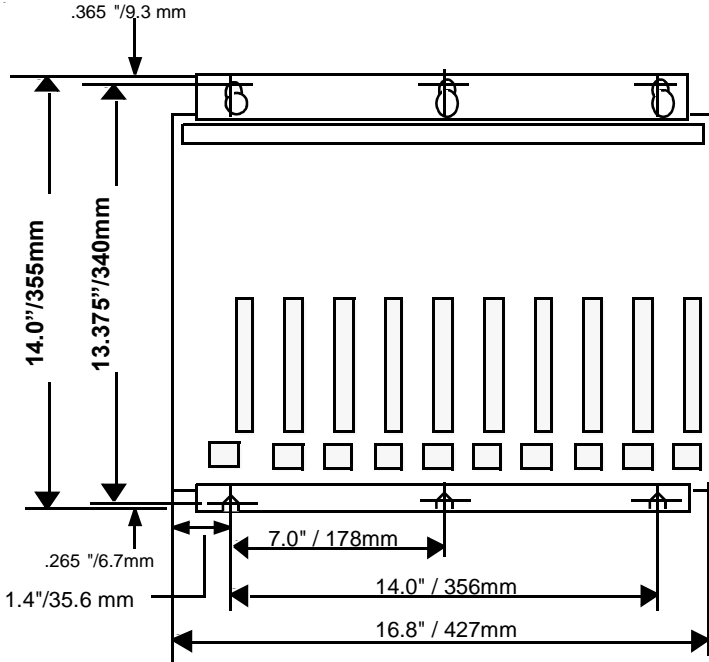

The 13-slot System Rack

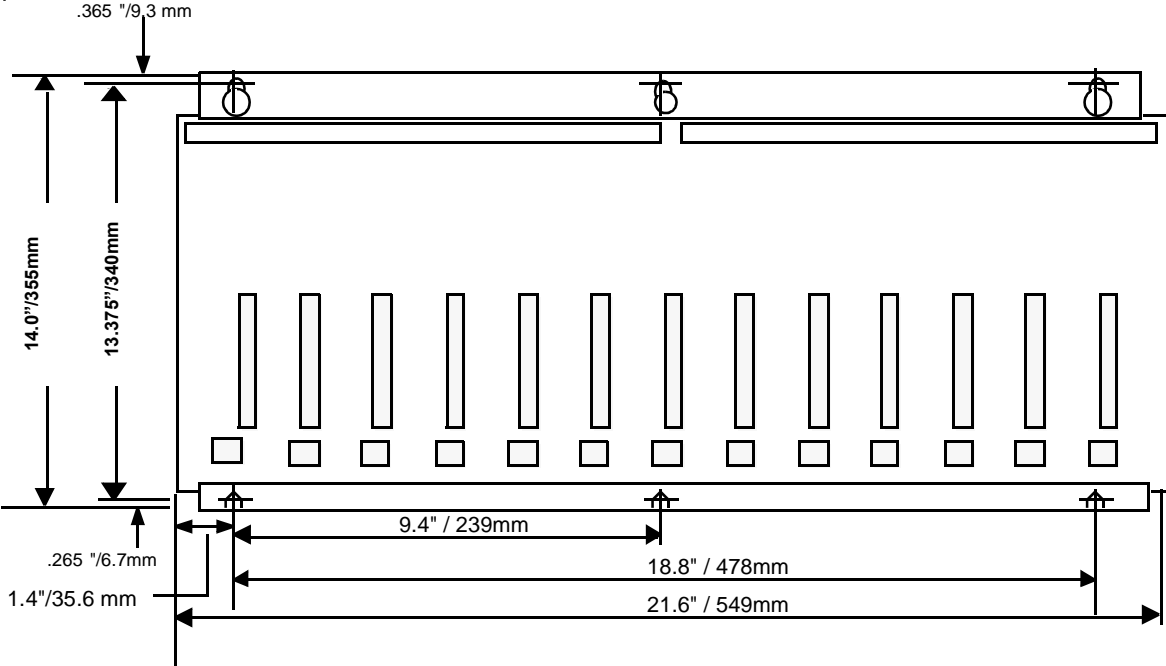

PiC900 CONTROLS

MOTION SOLUTIONS PRODUCT GUIDE

PiC Family CSM/ RSM Modules

Giddings & Lewis

CSM Module/RSM Module

The Central Service Module (CSM) and the Remote Service Module (RSM) convert incoming power to regulated DC power. Through the bus, the CSM supplies this power to the modules in the master rack and the RSM supplies this power to the modules in an expansion rack.

The CSM has the following additional features:

- Scan control which includes a key switch to run/stop the scan when power is on.
- A lithium battery to back up such items as non-volatile RAM in the CPU module and the time-of-day clock on the CSM module when power is turned off.
- An internal clock to provide time of day and date when needed by the software.

The CSM and the RSM must always be located in the first slot on the left in the master rack and expansion rack respectively.

CSM - the Central Service Module (for master rack)

RSM - the Remote Service Module (for expansion rack)

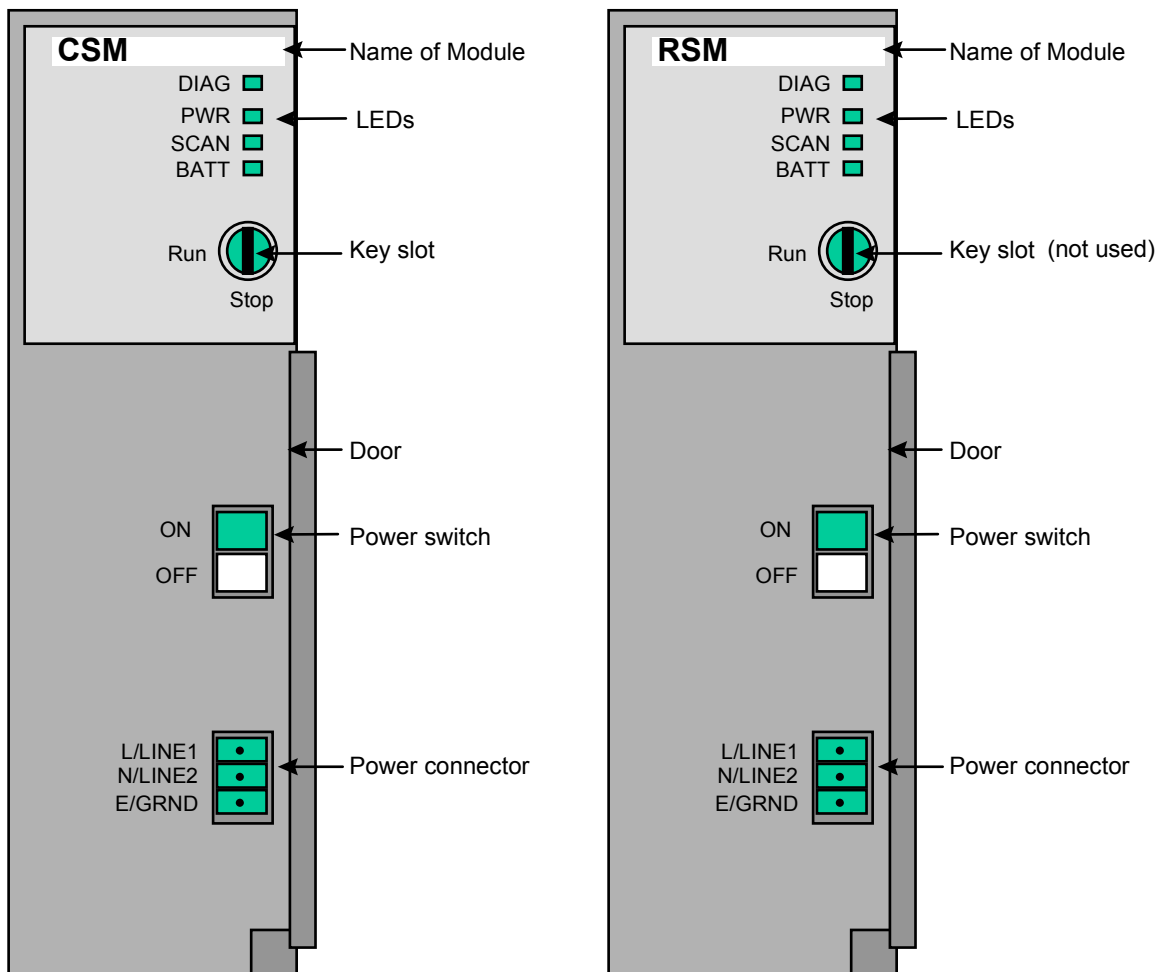

Specification Table

Characteristic	CSM/RSM specifications												
Functions	Supplies regulated DC power to the hardware modules installed in the rack												
AC power source	<table border="1" style="margin-left: auto; margin-right: auto;"> <thead> <tr> <th colspan="2" style="text-align: center;">110-230 VAC, 47-63 Hz, 2 A</th> </tr> <tr> <th style="text-align: left;">Model</th> <th style="text-align: left;">Part Number</th> </tr> </thead> <tbody> <tr> <td>CSM-50</td> <td>M.1016.8879 (old # 502-03512-03)</td> </tr> <tr> <td>CSM-60</td> <td>M.1016.9294 (old # 502-03813-03)</td> </tr> <tr> <td>RSM-50</td> <td>M.1016.9243 (old # 502-03732-03)</td> </tr> <tr> <td>RSM-60</td> <td>M.1016.9308 (old # 502-03817-03)</td> </tr> </tbody> </table>	110-230 VAC, 47-63 Hz, 2 A		Model	Part Number	CSM-50	M.1016.8879 (old # 502-03512-03)	CSM-60	M.1016.9294 (old # 502-03813-03)	RSM-50	M.1016.9243 (old # 502-03732-03)	RSM-60	M.1016.9308 (old # 502-03817-03)
110-230 VAC, 47-63 Hz, 2 A													
Model	Part Number												
CSM-50	M.1016.8879 (old # 502-03512-03)												
CSM-60	M.1016.9294 (old # 502-03813-03)												
RSM-50	M.1016.9243 (old # 502-03732-03)												
RSM-60	M.1016.9308 (old # 502-03817-03)												
DC power source	<table border="1" style="margin-left: auto; margin-right: auto;"> <thead> <tr> <th colspan="2" style="text-align: center;">20 - 60 VDC, 3 A</th> </tr> <tr> <th style="text-align: left;">Model</th> <th style="text-align: left;">Part Number</th> </tr> </thead> <tbody> <tr> <td>CSM-50 (24 VDC)</td> <td>M.1016.9475 (old # 502-03973-00)</td> </tr> </tbody> </table>	20 - 60 VDC, 3 A		Model	Part Number	CSM-50 (24 VDC)	M.1016.9475 (old # 502-03973-00)						
20 - 60 VDC, 3 A													
Model	Part Number												
CSM-50 (24 VDC)	M.1016.9475 (old # 502-03973-00)												
Input connector	3-terminal plug connector, meets all specifications for touch safety in accordance with IEC 529 and DIN VDE 0470 part 1												
Power output, total	<table border="1" style="margin-left: auto; margin-right: auto;"> <thead> <tr> <th style="text-align: left;">Model</th> <th style="text-align: left;">Power</th> </tr> </thead> <tbody> <tr> <td>CSM/RSM-50</td> <td>50 W</td> </tr> <tr> <td>CSM/RSM-60</td> <td>60 W</td> </tr> <tr> <td>CSM 24 VDC</td> <td>50 W</td> </tr> </tbody> </table>	Model	Power	CSM/RSM-50	50 W	CSM/RSM-60	60 W	CSM 24 VDC	50 W				
Model	Power												
CSM/RSM-50	50 W												
CSM/RSM-60	60 W												
CSM 24 VDC	50 W												
Individual outputs	<table border="1" style="margin-left: auto; margin-right: auto;"> <tbody> <tr> <td>+5 V @ 4.0 A</td> <td>+5 V @ 8.5 A</td> <td>+5 V @ 4.0 A</td> </tr> <tr> <td>+15 V @ 2.0 A</td> <td>+15 V @ 1.5 A</td> <td>+15 V @ 1.0 A</td> </tr> <tr> <td>-15 V @ .5 A</td> <td>-15 V @ 1.5 A</td> <td>-15 V @ .5 A</td> </tr> </tbody> </table>	+5 V @ 4.0 A	+5 V @ 8.5 A	+5 V @ 4.0 A	+15 V @ 2.0 A	+15 V @ 1.5 A	+15 V @ 1.0 A	-15 V @ .5 A	-15 V @ 1.5 A	-15 V @ .5 A			
+5 V @ 4.0 A	+5 V @ 8.5 A	+5 V @ 4.0 A											
+15 V @ 2.0 A	+15 V @ 1.5 A	+15 V @ 1.0 A											
-15 V @ .5 A	-15 V @ 1.5 A	-15 V @ .5 A											

Battery (CSM only) Part number	1.2 Ah 3 V, 2/3 A lithium battery M.1015.9316 (old # 401-52446-00)
+ 5 V supply monitor	Trip points $\pm 5\% \pm .5\%$: 4.725 to 4.775 V and 5.225 to 5.275 V PWR LED goes off and PiC shuts down
± 15 V supply monitor	Trip points $\pm 8\% \pm 2\%$: 13.5 to 14.1 V and 15.9 to 16.5 V
Time-of-day clock (CSM only)	Access via PiCPro or application program.
Clock tolerance (CSM only)	At 25°C, ± 1 second per day Over temperature, voltage and aging variation, $+2/-12$ seconds per day
Logic side power requirements (typical)	25 mA @ +5 V 2 mA @ +15 V 2 mA @ - 15 V 2 μ A @ +3 V (from battery during power down on CSM)
Operating temperature range	7°C to 55°C (45°F to 131°F)
Storage temperature range	-40°C to 85°C (-40°F to 185°F)
Humidity	5 to 95%, non-condensing
EMC Compliant Emissions Noise immunity	Refer to the EMC Guidelines for more information. Operates with emissions below EN55011/ CISPR 11 Class A limits Immune to: <ul style="list-style-type: none"> • Electrostatic discharge (4K V contact mode, 8K V air discharge) per IEC 1000-4-2 • RF electromagnetic fields per IEC 1000-4-3 • Electrical fast transients per IEC 1000-4-4 on incoming power lines

CE Marked	<p>Conforms to Directives 73/23/EEC, 89/336/EEC, 92/31/EEC, 93/68/EEC by conforming to the following standards:</p> <p>EN 50081-2:1993 EMC Generic Industrial Emissions EN 50082-2:1995 EMC Generic Industrial Immunity EN 61131-2:1994/A11:1996 Low voltage directive requirements for programmable controllers</p> <p>Operates with emissions below EN5501/CISPR 11 Class A limits</p> <p>Immune to:</p> <ul style="list-style-type: none"> • Electrostatic discharge (4K V contact mode, 8K V air discharge) per EN61000-4-2 • RF electromagnetic fields per EN61100-4-3, ENV50141, and ENV50204
UL and C/UL Listed (CSM/RSM-50)	File No. E126417 NRAQ Programmable Controllers
Physical size	2.4" wide x 12" high x 8.4" deep (including latch) 61 mm x 305 mm x 213 mm
Vibration (per IEC 68-2-7)	10-57 Hz (constant amplitude .15 mm) 57-2000Hz (acceleration 2 g)
Shock (per IEC 68-2-27)	Four shocks per axis (15g/11 msec)

PiC90 RSM I/O Module

When a PiC90 3- or 5-slot rack is used as a remote or local expansion rack for a PiC900 master rack, an RSM I/O driver module is required in slot 1/2 of the PiC90 rack.

The RSM I/O driver module converts AC power to regulated DC power. Through the bus, the RSM supplies this power to the modules in an expansion rack.

A PiC900 system may include up to eight expansion racks containing I/O modules. The RSM I/O driver module must be installed in each PiC90 3- or 5-slot expansion rack and an RSM module and an I/O driver module must be installed in each PiC900 7-, 10-, or 13-slot expansion rack.

The DIAG LED turns on briefly while the diagnostic tests are running.

RSM I/O - the Remote Service Module I/O Driver
(for 3- or 5- slot PiC90 expansion rack)

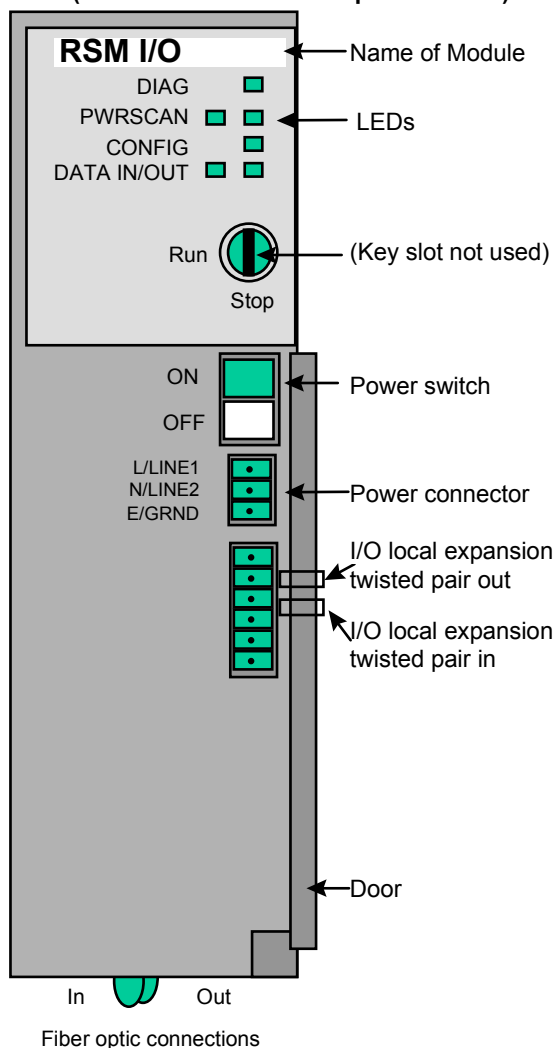

Specification Table

Characteristic	RSM I/O driver specifications
Functions	Supplies regulated DC power to hardware modules installed in the rack and allows additional racks of I/O modules to be connected to a PiC900 master rack
Part number	M.1016.9385 (old # 502-03876-02)
AC power source	120-230 V AC, 47-63 Hz
Input connector	3-terminal plug connector, meets all specifications for touch safety in accordance with IEC 529 and DIN VDE 0470 part 1
Power output, total	40 W
Individual outputs	+ 5 V @ 5.0 A + 15 V @ 2.0 A -15 V @ .5 A
+ 5 V supply monitor	Trip points $\pm 5\% \pm .5\%$: 4.725 to 4.775V and 5.225 to 5.275 V PWR LED goes off and PiC900 shuts down
Logic side power requirements (typical)	510 mA @ +5V
Operating temperature range	7° C to 55° C (45° F to 131° F)
Storage temperature range	-40° C to 85° C (-40° F to 185° F)
Humidity	5 to 95%, non-condensing
EMC Compliant Emissions Noise immunity	Refer to the EMC Guidelines for more information. Operates with emissions below EN55011/ CISPR 11Class A limits Immune to: <ul style="list-style-type: none"> • Electrostatic discharge (4K V contact mode, 8K V air discharge) per IEC 1000-4-2 • RF electromagnetic fields per IEC 1000-4-3 • Electrical fast transients per IEC 1000-4-4 on incoming power lines
UL and C/UL Listed	File No. E126417 NRAQ Programmable Controllers
Physical size	2.4" wide x 12" high x 8.4" deep (including latch) 61 mm x 305 mm x 213 mm
Vibration (per IEC 68-2-6)	10-57 Hz (constant amplitude .15 mm) 57-2000 Hz (acceleration 2 g)
Shock (per IEC 68-2-27)	Four shocks per axis (15g/11msec)

MOTION SOLUTIONS PRODUCT GUIDE

PiC Family CPU Modules

Giddings & Lewis

PiC94X CPU Module

The PiC94X Turbo CPU module controls the PiC900 system and executes the application program. It contains:

- A processor IC providing overall control
- A math coprocessor
- Eight LEDs
- RAM (EPROM optional) memory for the application program and for RAMDISK
- RAM memory for data storage as the system runs
- FLASH memory for the system software
- RS232 ports to communicate with the computer workstation and with a serial interface device
- Optional communication (ARCNET, I/O, and Block I/O expansion) capability
- Optional flash memory for storing things like application source modules

The CPU module must always be in the second slot from the left in the system rack.

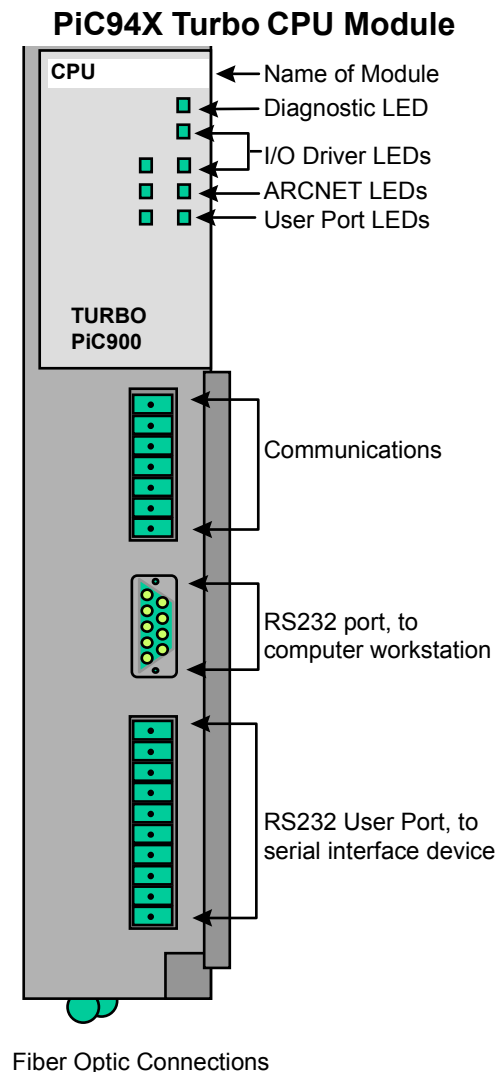

Specification Table

Characterisitcs							CPU 94X module specifications				
Function							Executes the application program. Executes Diagnostics on the system and it's modules. Communicates through RS232 port to external devices. Can provide ARCNET and I/O expansion from module.				
CPUs							Number of servo axes available at five update rates **				
Model	CPU	Part Number	Speed	App Mem	RAM Mem	User Mem	8 ms	4 ms	2 ms	1 ms	.5 ms
941	80486DX2	M.1016.9626 (old # 502-04111-01)	16 MHz	512K	256K	64K	16	8	4	2	1
Turbo ²	80486DX2	M.1016.9627 (old # 502-04111-11)*	16 MHz	512K	256K	64K	16	8	4	2	1
943	80486DX2	M.1016.9508) (old # 502-04011-01)	32 MHz	512K	256K	64K	32	16	8	4	2
Turbo ²	80486DX2	M.1016.9510 (old # 502-04011-11)*	32 MHz	512K	256K	64K	32	16	8	4	2
945											
Turbo ³	80486DX2	M.1016.9491 (old # 502-03994-11)*	50 MHz	512K	256K	64K	32	32	16	8	4
947											
Turbo ³	80486DX4	M.1016.9629 (old # 502-04112-11)*	100MHz	512K	256K	64K	32	32	24	12	8

*ARCNET and I/O expansion communications are standard on these modules.

**The number of axes listed is typical for RATIO_GR, RATIOCAM, VEL_STRT, POSITION and DISTANCE move types. Applications which use time axes, servo tasks, RATIO_RL, M_LINCIR, or M_SCRVLC moves require more CPU time. Consult Giddings & Lewis for assistance if you want to exceed the number of axes in this chart.

Flash memory system board (optional)	8 Megabyte FMS Board M.1016.9390 (old # 502-03882-20)																												
Memory	1 Megabyte max.																												
PiCPro Port (to workstation)	RS232 serial port, secured protocol Software selectable baud rate to 115.2K																												
User Port (to serial interface device)	RS232 serial port Supports RTS/CTS hardware handshaking Software selectable baud rate to 19.2K																												
Logic side power requirements (typical)	<table border="1"> <thead> <tr> <th>Part Number</th> <th>+5 V</th> <th>+ 15 V</th> <th>-15 V</th> </tr> </thead> <tbody> <tr> <td>M.1016.9626 (old # 502-04111-01)</td> <td>700 mA</td> <td>4 mA</td> <td>10 mA</td> </tr> <tr> <td>M.1016.9508 (old # 502-04011-01)</td> <td>800 mA</td> <td>4 mA</td> <td>10 mA</td> </tr> <tr> <td>M.1016.9627 (old # 502-04111-11)*</td> <td>900 mA</td> <td>4 mA</td> <td>39 mA</td> </tr> <tr> <td>M.1016.9510 (old # 502-04011-11)*</td> <td>1000 mA</td> <td>4 mA</td> <td>39 mA</td> </tr> <tr> <td>M.1016.9491 (old # 502-03994-11)*</td> <td>1400 mA</td> <td>4 mA</td> <td>39 mA</td> </tr> <tr> <td>M.1016.9629 (old # 502-04112-11)*</td> <td>1100 mA</td> <td>4 mA</td> <td>39 mA</td> </tr> </tbody> </table> <p>All CPUs draw 15 μA from the battery during power down. * CPUs with ARCNET and I/O capabilities on board.</p>	Part Number	+5 V	+ 15 V	-15 V	M.1016.9626 (old # 502-04111-01)	700 mA	4 mA	10 mA	M.1016.9508 (old # 502-04011-01)	800 mA	4 mA	10 mA	M.1016.9627 (old # 502-04111-11)*	900 mA	4 mA	39 mA	M.1016.9510 (old # 502-04011-11)*	1000 mA	4 mA	39 mA	M.1016.9491 (old # 502-03994-11)*	1400 mA	4 mA	39 mA	M.1016.9629 (old # 502-04112-11)*	1100 mA	4 mA	39 mA
Part Number	+5 V	+ 15 V	-15 V																										
M.1016.9626 (old # 502-04111-01)	700 mA	4 mA	10 mA																										
M.1016.9508 (old # 502-04011-01)	800 mA	4 mA	10 mA																										
M.1016.9627 (old # 502-04111-11)*	900 mA	4 mA	39 mA																										
M.1016.9510 (old # 502-04011-11)*	1000 mA	4 mA	39 mA																										
M.1016.9491 (old # 502-03994-11)*	1400 mA	4 mA	39 mA																										
M.1016.9629 (old # 502-04112-11)*	1100 mA	4 mA	39 mA																										
Operating temperature range	7°C to 55°C (45°F to 131°F)																												
Storage temperature range	-40°C to 85°C (-40°F to 185°F)																												
Humidity	0 to 95%, non-condensing																												

EMC Compliant Emissions Noise immunity	Operates with emissions below EN55011/ CISPR 11 Class A limits Immune to: <ul style="list-style-type: none"> • Electrostatic discharge (4K V contact mode, 8K V air discharge) per IEC1000-4-2 • RF electromagnetic fields per IEC 1000-4-3 • Electrical fast transients per IEC 1000-4-4 on incoming power lines Refer to the EMC Guidelines for more information.
UL and C/UL Listed	File No. E126417 NRAQ Programmable Controllers
Physical size	1.6" wide x 12" high x 8.4" deep (including latch) 41 mm x 305 mm x 213 mm
Vibration (per IEC 68-2-6)	10-57 Hz (constant amplitude .15mm) 57-2000 Hz (acceleration 2g)
Shock (per IEC 68-2-27)	Four shocks per axis (15g/11 msec)

NOTES

PiC904X- CSM/CPU Central Service Module/Central Processing Unit

The PiC9041 or 9043 CSM/CPU module occupies the 1/2 slot in the rack.

The CSM/CPU converts AC or DC power to regulated DC power. It supplies this power to the modules in the rack through the bus. The CSM/CPU controls the PiC90 system and executes the application program.

PiC904X CSM/CPU Module

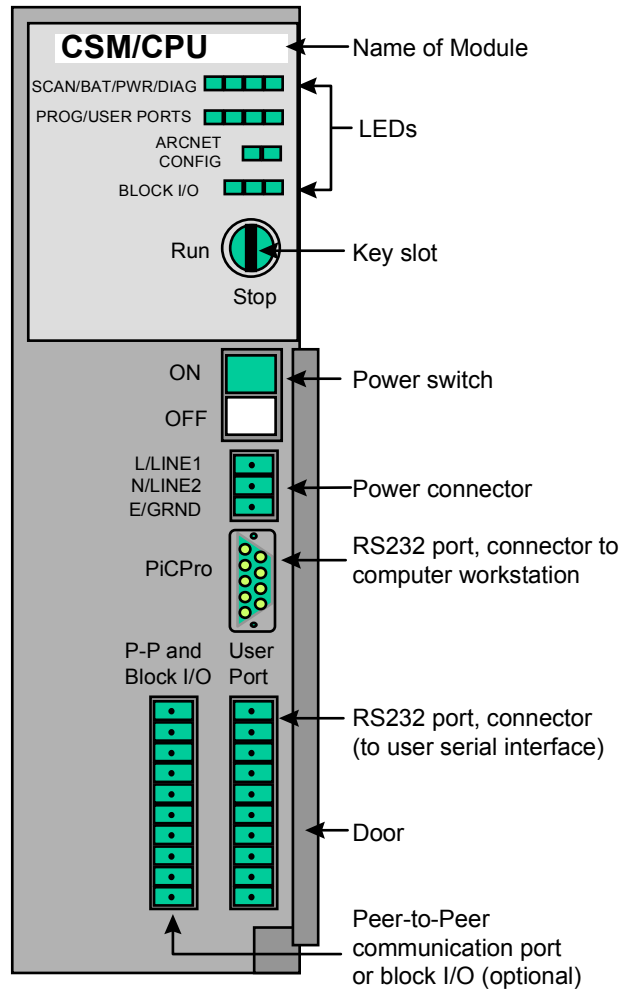

Specification Table

Characterisitcs		CSM/CPU specifications									
Functions		Supplies regulated DC power to the hardware modules installed in the rack. Executes the application program. Executes Diagnostics on the system and it's modules. Communicates through RS232 port to external devices. Peer -to-peer communications with PiC family of controls (optional).									
Models available							Number of servo axes available at six update rates *				
PiC90 Model (with AC Power Source)	Part Number	Speed	App Mem	RAM Mem	User Mem	8 ms	4 ms	2 ms	1 ms	.5 ms	.25 ms
9041 Standard w/o comm	M.1016.9615 (old # 502-04104-01)	16 MHz	256K	128K	64K	12	6	4	2	1	0
9041 Standard w/ comm	M.1016.9617 (old # 502-04104-11)	16 MHz	256K	128K	64K	12	6	4	2	1	0
9043 Turbo w/o comm	M.1016.9677 (old # 502-04125-01)	32 MHz	256K	128K	64K	12	12	8	4	2	1
9043 Turbo w/ comm	M.1016.9679 (old # 502-04125-11)	32 MHz	256K	128K	64K	12	12	8	4	2	1
PiC90 Model (with DC Power Source)											
9043 Turbo w/ comm	M.1016.9682 (old # 502-04126-10)	32 MHz	256K	128K	64K	12	12	8	4	2	1

*The number of axes listed is typical for RATIO_GR, RATIOCAM, VEL_STRT, POSITION and DISTANCE move types. Applications which use time axes, servo tasks, RATIO_RL, M_LINCIR, or M_SCRVLC moves require more CPU time. Consult Giddings & Lewis for assistance if you want to exceed the number of axes in this chart.

PiC904X- CSM/CPU Central Service Module/Central Processing Unit

AC power source	110-230 V AC, 47-63 Hz, 1A												
DC power source	20 -30V DC, 3 A												
Input connector	3-terminal plug connector, meets all specifications for touch safety in accordance with IEC 529 and DIN VDE 0470 part 1												
Power output, total	CSM/CPU 40 W (for AC power source) 30 W (for DC power source)												
Individual outputs	<table border="1"> <thead> <tr> <th></th> <th>AC Power Source</th> <th>DC Power Source</th> </tr> </thead> <tbody> <tr> <td>+ 5V @</td> <td>5.0 A</td> <td>3 A</td> </tr> <tr> <td>+ 15V @</td> <td>2.0 A</td> <td>1 A</td> </tr> <tr> <td>-15V @</td> <td>.5 A</td> <td>.5 A</td> </tr> </tbody> </table>		AC Power Source	DC Power Source	+ 5V @	5.0 A	3 A	+ 15V @	2.0 A	1 A	-15V @	.5 A	.5 A
	AC Power Source	DC Power Source											
+ 5V @	5.0 A	3 A											
+ 15V @	2.0 A	1 A											
-15V @	.5 A	.5 A											
Battery	1.2 Ah 3V, 2/3A lithium battery												
+ 5 V supply monitor	Low trip point 4.50V min 4.75V max High trip point 5.50V min 5.94V max PWR LED goes off and PiC9041 shuts down												
Flash memory system board (optional)	8 Megabyte FMS Board M.1016.9390 (old # 502-03882-20)												
PiCPro port	Used to connect to the work station RS232 serial port, secured protocol Software selectable baud rate (300 to 57600 baud)												
User port	Used to connect to a serial interface device RS232 serial port Supports RTS/CTS hardware handshaking Baud rates to 19.2 K												
Peer-to-peer communications (optional)	Allows for communication between PiC90s and/or PiC900s (up to 255) A dedicated network controller supports peer-to-peer communications. Provides a twisted pair wire interface that is transformer isolated. Data is transferred serially at a rate of 2.5 megabits per second.												
Block I/O expansion (optional)	Allows for communication between the PiC90 and block I/O modules (up to 77) The maximum distance between modules is 200 feet using shielded twisted pair wire												
Time-of-day clock	Access via PiCPro or application program.												
Clock tolerance	At 25° C, ±1 second per day Over temperature, voltage and aging variation, +2/-12 seconds per day												

Central Processing Unit

Logic side power requirements (typical)	450 mA @ +5V 650 mA @ +5V 600 mA @ +5V 800 mA @ +5V 5 mA @ +15V 10 mA @ -15V 40 mA @ -15V 5 μ A @ +3V	M.1016.9615 (old # 502-04104-01) M.1016.9617 (old # 502-04104-11) M.1016.9677 (old # 502-04125-01) M.1016.9679 (old # 502-04125-11), M.1016.9682 (old # 502-04126-10) all M.1016.9615 (old # 502-04104-01), M.1016.9677 (old # 502-04125-01) M.1016.9617 (old # 502-04104-11), M.1016.9678 (old # 502-04125-10), M.1016.9682 (old # 502-04126-10) (all) From the battery during power down
Operating temperature range	7° C to 55° C (45° F to 131° F)	
Storage temperature range	-40° C to 85° C (-40° F to 185° F)	
Humidity	5 to 95%, non-condensing	
EMC Compliant	In progress	
CE Marked	<p>Conforms to Directives 73/23/EEC, 89/336/EEC, 92/31/EEC, 93/68/EEC by conforming to the following standards:</p> <p>EN 50081-2:1993 EMC Generic Industrial Emissions EN 50082-2:1995 EMC Generic Industrial Immunity EN 61131-2:1994/A11:1996 Low voltage directive requirements for programmable controllers</p> <p>Operates with emissions below EN5501/CISPR 11 Class A limits</p> <p>Immune to:</p> <ul style="list-style-type: none"> • Electrostatic discharge (4K V contact mode, 8K V air discharge) per EN61000-4-2 • RF electromagnetic fields per EN61100-4-3, ENV50141, and ENV50204 • Electrical fast transients per EN61000-4-4 • Magnetic fields per EN61000-40 	
UL and C/UL Listed	File No. E1226417 NRAQ Programmable Controllers	
Physical size	2.4" wide x 12" high x 8.4" deep (including latch) 61 mm x 305 mm x 213 mm	
Vibration (per IEC 68-2-6)	10-57 Hz (constant amplitude .15 mm) 57-2000 Hz (acceleration 2 g)	
Shock (per IEC 68-2-27)	Four shocks per axis (15g/11msec)	

**PiC900 CONTROLS
MOTION SOLUTIONS PRODUCT GUIDE**

PiC 900 Communications Modules

Giddings & Lewis

Ethernet - TCP/IP Module

The Ethernet - TCP/IP module provides the PiC with Ethernet access and Internet connectivity. Connections for 10Base T, 10Base 2, and AUI (Attachment Unit Interface) are provided following the IEEE 802.3 specification. The data transfer rate is 10 Mbps. Applications can range from connecting several PiCs, connecting groups of PiCs and PCs, or connecting to a system that includes Internet access.

The Remote Programmer Access key will allow you to enable/disable PiCPro for Windows running over Ethernet. The DIAG LED goes on briefly while the diagnostic tests are running shortly after power is applied.

NOTE: The Ethernet module must be used with an EMC-compliant or CE-marked rack.

Ethernet - TCP/IP Module

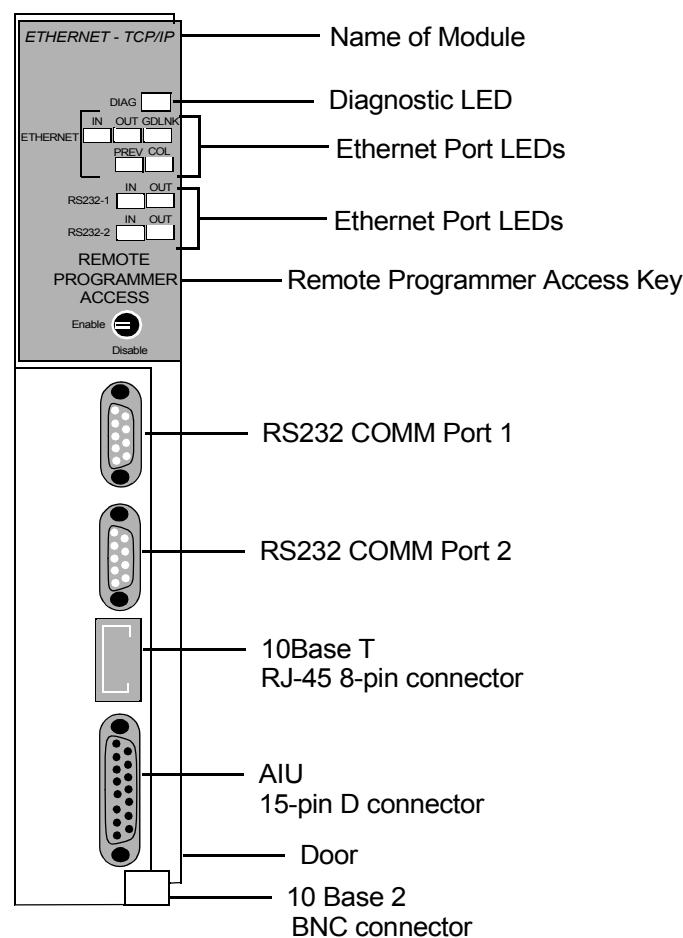

Specification Table

Characteristics	Ethernet - TCP/IP Module Specifications
Function	Provides the PiC with Ethernet access and Internet connectivity
Part number	M.1016.9694 (old # 502-04137-00)
RS232 Port 1	Com Port 1 modem (future)
RS232 Port 2	Com Port 2 (for firmware and configuration loading)
10Base T	RJ-45 8-pin connector Maximum twisted pair length is 100 m (328 ft.).
AUI	15-pin D connector Maximum twisted pair length is 50 m (164 ft.).
10Base 2	BNC connector Maximum coax cable length is 185 m (607 ft.).
Logic side power requirements (typical)	+5V @ 1250 mA +15V @ 30 mA maximum -15V @ 30 mA maximum
Operating temperature range	7° C to 55° C (45° F to 131° F)
Storage temperature range	-40° C to 85° C (-40° F to 185° F)
Humidity	5 to 95%, non-condensing
EMC Compliant	
Emissions	Operates with emissions below EN55011/ CISPR 11 Class A limits
Noise immunity	Immune to: <ul style="list-style-type: none"> • Electrostatic discharge (4K V contact mode, 8KV air discharge) per IEC 1000-4-2 • RF electromagnetic fields per IEC 1000-4-3 • Electrical fast transients per IEC 1000-4-4 on incoming power lines Refer to the EMC Guidelines for more information.

CE Marked	<p>Conforms to Directives 73/23/EEC, 89/336/EEC, 92/31/EEC, 93/68/EEC by conforming to the following standards:</p> <p>EN 50081-2:1993 EMC Generic Industrial Emissions EN 50082-2:1995 EMC Generic Industrial Immunity EN 61131-2:1994/A11:1996 Low voltage directive requirements for programmable controllers</p> <p>Operates with emissions below EN5501/CISPR 11 Class A limits</p> <p>Immune to:</p> <ul style="list-style-type: none"> • Electrostatic discharge (4K V contact mode, 8K V air discharge) per EN61000-4-2 • RF electromagnetic fields per EN61100-4-3, ENV50141, and ENV50204
UL and C/UL Listed	File No. E126417 NRAQ Programmable Controllers
Physical size	1.6" wide x 12" high x 8.4" deep (including latch) 41 mm x 305 mm x 213 mm
Vibration (per IEC 68-2-6)	10-57 Hz (constant amplitude .15 mm) 57 - 2000 Hz (acceleration 2 g)
Shock (per IEC 68-2-27)	Four shocks per axis (15g/11 msec)

DeviceNet Module

The DeviceNet scanner module is an interface between the PiC and a DeviceNet network. The module contains an on-board processor, a DeviceNet compliant interface, and firmware that makes it act as the master to all other nodes on the network.

Prior to initial operation, a file is generated with specific configuration software in an external PC. This file must be downloaded via the RS232 configuration port to the DeviceNet module prior to initial operation. Two indicator LEDs (IN/OUT) are connected to this configuration port.

Directly above the DeviceNet port are two LEDs that provide operation information: Network Status and DeviceNet Scanner Status.

The DIAG LED goes on briefly while the diagnostics tests are running.

NOTE: The DeviceNet module must be used with an EMC-compliant or CE-marked rack.

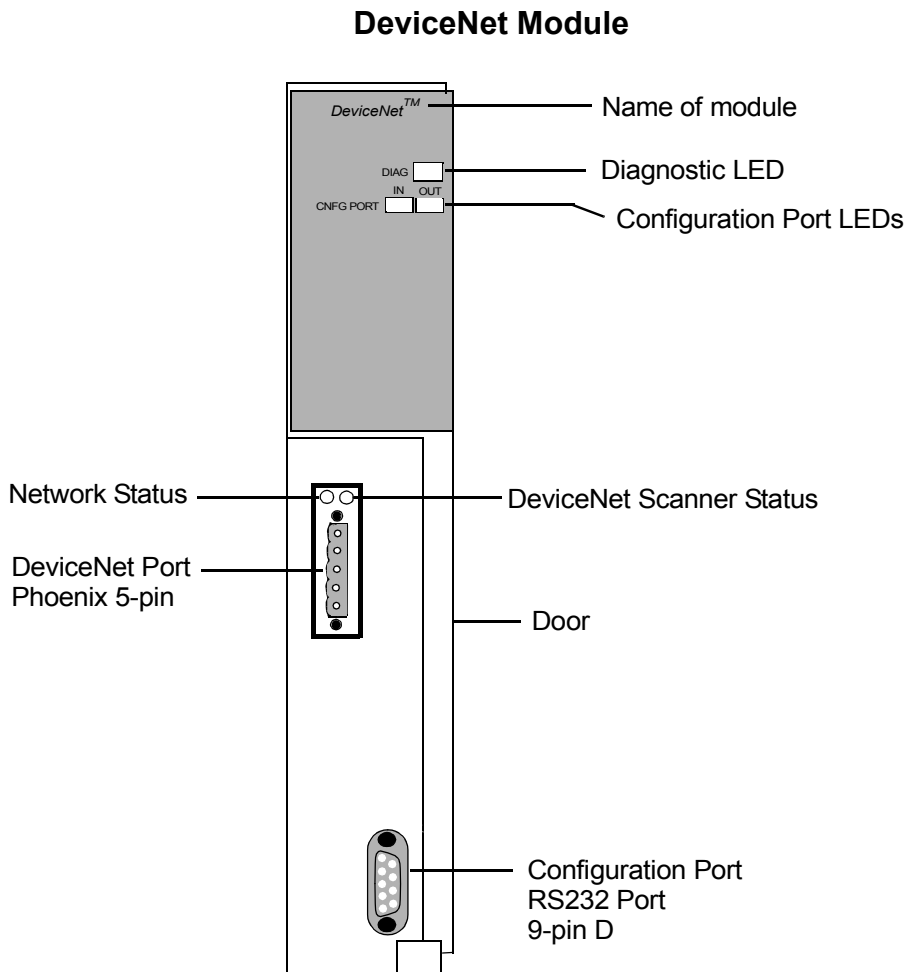

Specification Table

Characteristics	DeviceNet Module Specifications
Function	Interfaces to a DeviceNet network with up to 63 other nodes
Part number	M.1016.9719 (old # 502-04157-00)
DeviceNet Port	Phoenix style 5-pin male connector
Configuration Port	RS232 interface
Logic side power requirements (typical)	275 mA @ 5 V
Operating temperature range	7° C to 55° C (45° F to 131° F)
Storage temperature range	-40° C to 85° C (-40° F to 185° F)
Humidity	5 to 95%, non-condensing
EMC Compliant	
Emissions	Operates with emissions below EN55011/ CISPR 11 Class A limits
Noise immunity	Immune to: <ul style="list-style-type: none"> • Electrostatic discharge (4K V contact mode, 8KV air discharge) per IEC 1000-4-2 • RF electromagnetic fields per IEC 1000-4-3 • Electrical fast transients per IEC 1000-4-4 on incoming power lines Refer to the EMC Guidelines for more information.
UL and C/UL Listed	File No. E126417 NRAQ Programmable Controllers
Physical size	1.6" wide x 12" high x 8.4" deep (including latch) 41 mm x 305 mm x 213 mm
Vibration (per IEC 68-2-6)	10-57 Hz (constant amplitude .15 mm) 57 - 2000 Hz (acceleration 2 g)
Shock (per IEC 68-2-27)	Four shocks per axis (15g/11 msec)

Serial Communications Module (2, 4 channel)

The serial communications module provides two or four channels to be used for asynchronous serial communication with external devices such as computers, operator interface devices, etc. For each channel, RS232 electrical interface is provided for data and control lines; RS422/485 electrical interface is provided for data lines.

The DIAG LED goes on briefly while the diagnostic tests are running

Serial COMMUNICATIONS Module (2, 4 ch)

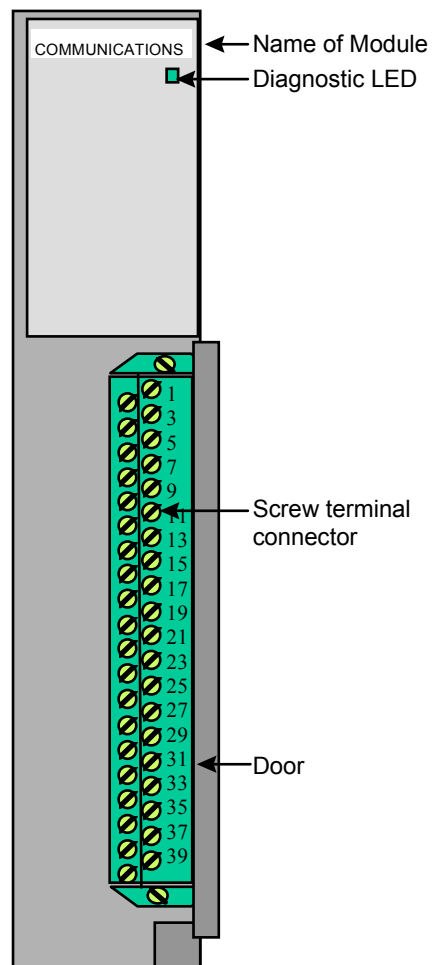

Specification Table

Characteristics	Communications Module Specifications
Function	Provides 2 or 4 asynchronous serial communication channels to be used with serial interface devices
Part number	2 channel - M.1016.9143 (old # 502-03676-23) 4 channel - M.1016-9140 (old # 502-03676-03)
Dedicated processor	80C186, 8 MHz, 32K x 16 EPROM, 8K x 16 RAM
Ports 1, 2, 3, and 4	RS232 or RS422/485 electrical interface Supports RTS/CTS hardware handshaking Baud rates to 19.2 Kbps
Logic side power requirements (typical)	420 mA @ +5V (2 ch) 450 mA @ +5V (4 ch) 5 mA @ +15V 5 mA @ -15V 50 mA per terminated RS422/485 channel @ +5V 5 mA per active RS232 channel @ +15V 6 mA per active RS232 channel @ -15V
Operating temperature range	7° C to 55° C (45° F to 131° F)
Storage temperature range	-40° C to 85° C (-40° F to 185° F)
Humidity	5 to 95%, non-condensing
EMC Compliant Emissions Noise immunity	Operates with emissions below EN55011/ CISPR 11 Class A limits Immune to: <ul style="list-style-type: none"> • Electrostatic discharge (4K V contact mode, 8K V air discharge) per IEC 1000-4-2 • RF electromagnetic fields per IEC 1000-4-3 • Electrical fast transients per IEC 1000-4-4 on incoming power lines Refer to the EMC Guidelines for more information.

Serial Communications Module (2, 4 channel)

CE Marked	<p>Conforms to Directives 73/23/EEC, 89/336/EEC, 92/31/EEC, 93/68/EEC by conforming to the following standards:</p> <p>EN 50081-2:1993 EMC Generic Industrial Emissions EN 50082-2:1995 EMC Generic Industrial Immunity EN 61131-2:1994/A11:1996 Low voltage directive requirements for programmable controllers</p> <p>Operates with emissions below EN5501/CISPR 11 Class A limits</p> <p>Immune to:</p> <ul style="list-style-type: none"> • Electrostatic discharge (4K V contact mode, 8K V air discharge) per EN61000-4-2 • RF electromagnetic fields per EN61100-4-3, ENV50141, and ENV50204
UL and C/UL Listed	File No. E126417 NRAQ Programmable Controllers
Physical size	1.6" wide x 12" high x 8.4" deep (including latch) 41 mm x 305 mm x 213 mm
Vibration (per IEC 68-2-6)	10-57 Hz (constant amplitude .15mm) 57-2000 Hz (acceleration 2g)
Shock (per IEC 68-2-27)	Four shocks per axis (15g/11msec)

I/O Expansion

Local I/O Expansion

Local I/O Expansion allows additional PiC900 or PiC90 racks of input/output modules to be connected to a PiC900 master rack within the same cabinet. The diagram below shows three expansion racks connected to a master rack.

Local I/O Expansion

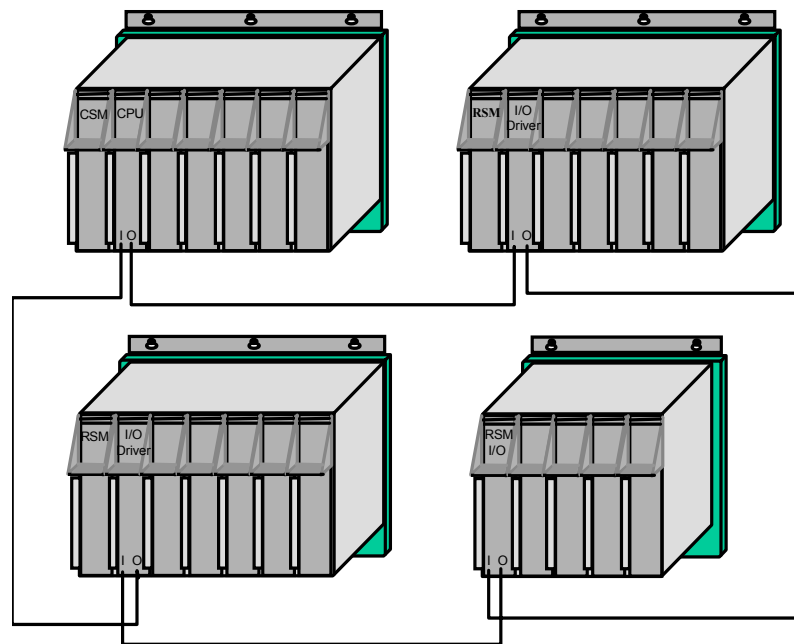

NOTE: When a PiC900 rack is used for expansion, an RSM (or CSM) module is placed in slot 1 and the I/O driver module is placed in slot 2. When a PiC90 rack is used for expansion, the RSM I/O driver module is placed in slot 1/2.

Expansion Modules

Expansion is accomplished with a PiC9XX CPU module with communication capabilities in the master rack and an I/O expansion driver for each additional rack. Up to seven expansion drivers with the PiC9XX can be linked to a master rack.

Wiring

All cables are twisted pairs of wires. The maximum distance (from rack to rack) is 40 feet.

Addressing

All addressing of modules is software defined - no address switches are required.

Remote I/O Expansion

Remote I/O Expansion allows for additional racks of input/output module in remote cabinets to be connected to the PiC900 master rack. The diagram below shows two expansion racks. NOTE: It is possible to combine local and remote expansion racks in the same system. Use twisted pair wiring to connect racks that are in the same cabinet (local) as the master rack and use fiber optic cable to connect racks that are up to 2000 feet apart (remote).

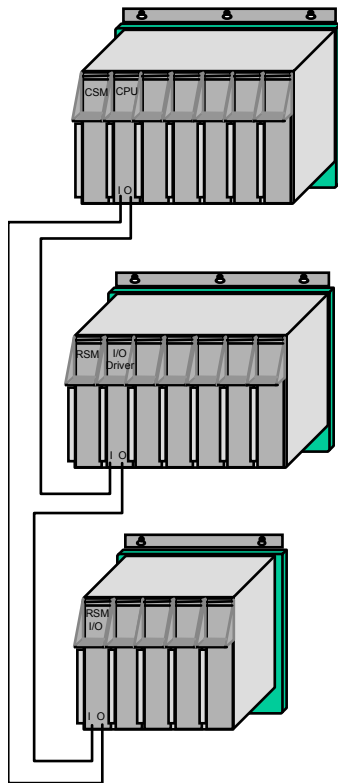

Expansion Modules

Communication with expansion is accomplished by using the following:

- For the PiC900 Master Rack, a PiC9XX CPU module with communication capabilities.
- For a PiC900 Expansion Rack, a RSM or CSM module in slot 1 *and* an I/O driver module in slot 2.
- For a PiC90 Expansion Rack, an RSM I/O module in slot 1/2.

Seven (with the PiC9XX) expansion drivers can be linked to a master rack.

Wiring

All cables are fiber optic. The maximum distance (rack to rack) is 2000 feet. (The maximum loop distance is 4000 feet.)

Circuitry

Expansion circuitry on the I/O driver modules provides for parallel to serial and serial to parallel conversions.

Addressing

All addressing of modules is software defined - no address switches are required.

Block I/O Expansion

Block I/O is a self-contained I/O interface with its own logic power supply derived from an external 24V DC source. Each block has a communication interface that includes two transmitters (RS485) and two receivers (optically isolated). Blocks differ as to the type of I/O interface (analog or digital) provided.

Block I/O is an alternative to PiC900 rack I/O expansion. It is used to distribute small groups of interface logic close to the actual location of I/O devices. It allows you to replace long runs of I/O cables with twisted pairs of communication wires. The Block I/O footprint has been minimized for easy installation into small enclosures or junction boxes.

NOTE: Block I/O cannot be intermixed within a rack I/O expansion loop. Block I/O uses a slower data rate and optical isolation to accommodate longer distances between modules. Block I/O can be used with MMCs, PiC900s and PiC90s.

One possible layout for PiC expansion using block I/O modules is shown below. There can be up to 200 feet between block I/O modules. The recommended wire is Belden 9729, 24 AWG stranded conductors, twisted pair (100 Ω characteristic impedance) with shield.

Block I/O Layout for PiC90/900 Expansion

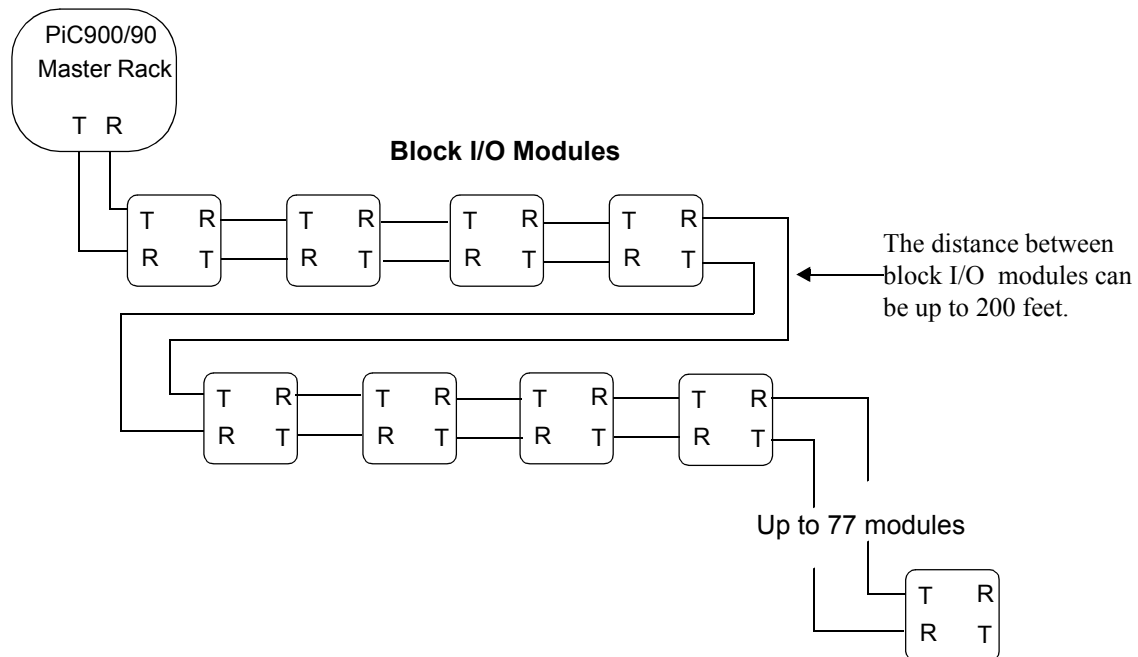

NOTE: Unlike wiring for I/O expansion racks, it is not necessary to return the last block I/O module back to the PiC. The interconnecting cable between block I/O modules contains both a forward and a return communication path.

Ordering Information

I/O expansion requires a PiC9XX CPU or a PiC904X CSM/CPU module with communication capabilities. Also required is an RSM (or CSM) module and an I/O driver module installed in PiC900 expansion racks and an RSM I/O driver module installed in PiC90 expansion racks.

	Part number	Description
PiC94X master rack	M.1016.9627 (old # 502-04111-11) M.1016.9510 (old # 502-04011-11) M.1016.9491 (old # 502-03994-11) M.1016.9629 (old # 502-04112-11)	CPUs with Communication Capabilities on Board
PiC904X master rack	M1016.9617 (old # 502-04104-11) M.1016.9679 (old # 502-04125-11) M.1016.9682 (old # 502-04126-10)	CSM/CPUs with Communication Capabilities on Board
PiC900 expansion rack	M.1016.9243 (old # 502-03732-03) M.1016.9308 (old # 502-03817-03)	RSM-50W Module <i>or</i> RSM-60W Module <i>or</i>
	M.1016.8879 (old # 502-03512-03) M.1016.9294 (old # 502-03813-03)	CSM-50W Module <i>or</i> CSM-60W Module <i>and</i>
	M.1016.9105 (old # 502-03657-03)	I/O driver Module
PiC90 expansion rack	M.1016.9385 (old # 502-03876-02)	RSM I/O driver Module

Remote I/O requires fiber optic cable:

Length of Fiber Optic Cable for Above	Part Number
10'	M.1016.9210 (old # 502-03700-10)
25'	M.1016.9215 (old # 502-03700-25)
50'	M.1016.9217 (old # 502-03700-50)
75'	M.1016.9219 (old # 502- 03700-75)
100'	M.1016.9222 (old # 502-03701-00)
125'	M.1016.9225 (old # 502-03701-25)
150'	M.1016.9227 (old # 502-03701-50)
175'	M.1016.9228 (old # 502-03701-75)

*Refer to the I/O expansion section of the Product Guide to determine the number of fiber optic cables required for your application.

**PiC900 CONTROLS
MOTION SOLUTIONS PRODUCT GUIDE**

PiC 900 Discrete I/O Modules

Giddings & Lewis

Input 24V DC Module (32 or 16 points)

The 24V DC input module converts DC signals from 32 or 16 devices into logic levels that the CPU can use. Each signal is converted into a corresponding logic 1 or 0 which is transmitted through the system bus to the CPU module. An "on" signal is nominally 24 V DC, but can be any level between 14 and 30 volts. An "off" signal is any level below 5V. The wiring configurations may be sink or source.

32 or 16 LEDs in the upper section of the module indicate the logic state of each input. The DIAG LED goes on briefly while the diagnostics tests are running.

Input 24V DC Module (32 and 16 Points)

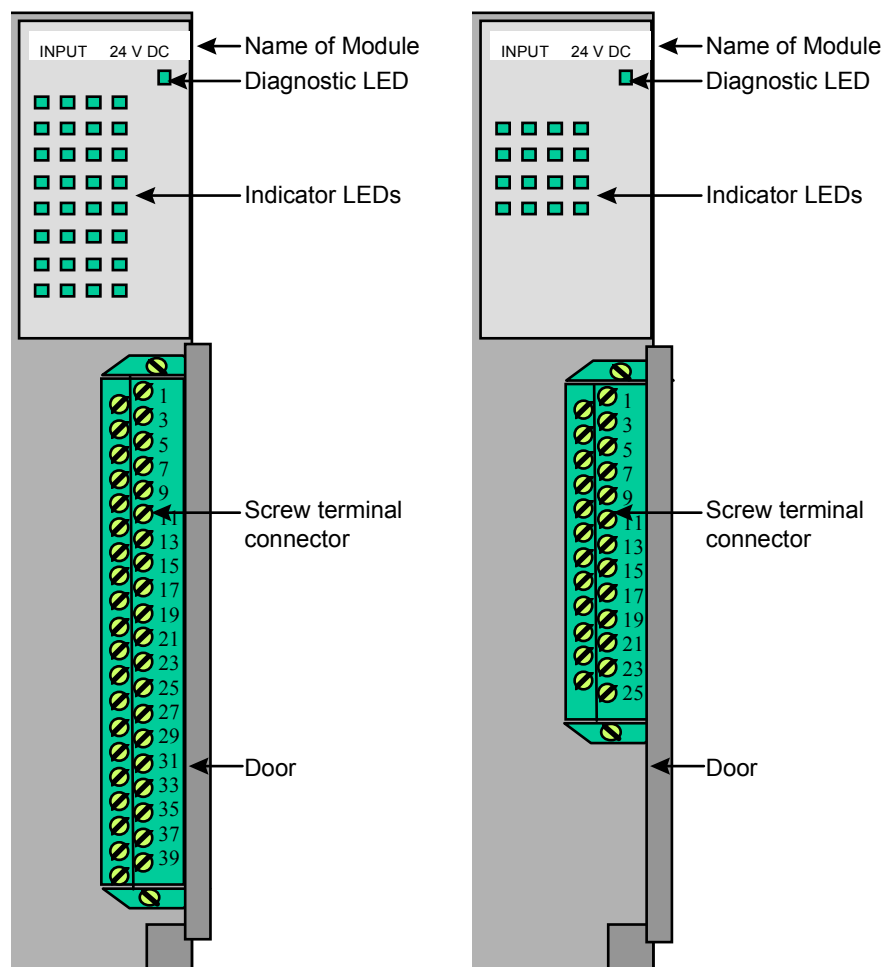

Specification Table

Characteristic	Input 24V DC module specifications
Function	Monitors on/off states from DC voltage inputs
Part number	32 point M.1016.9010 (old # 502-03605-00) 16 point M.1016.8929 (old # 502-03548-00)
Field side connector	32 point 40-pin card edge connector, screw terminals 16 point 25-pin card edge connector, screw terminals
Input signals (exceed IEC standards)	Nominal 24V DC on, 0V DC off
UH Max (max. allowed voltage)	30V DC
IH Max (max. current @ 30V DC)	7.5 mA
UL Min	Polarity independent
Guaranteed on	14V DC
IH Min (min. current @ UH Min)	2.8 mA
Guaranteed off	5V DC
IT Min (current allowed when off)	.75 mA
Time delay on	1 ms max.
Time delay off	1 ms max.
Protection of logic circuits	Optical isolation between the logic and field sides, 4000V peak
Input groups	Four groups of 8 or 4 IEC Type 1 inputs per NEMA Standard, ICS 3-1983, Table 3-304-2. UL 508 spacing
Indicator lights, input circuits	An LED indicates the logic state of each input
Indicator light, module	The DIAG LED goes OFF when the module passes power-on diagnostic tests
Logic side power requirements (typical)	32 point 29 mA @+5 V 7 mA per energized input @+5 V 16 point 2 mA @+5 V 7 mA per energized input @+5 V
Field side power dissipation, worst case	32 point 7.2 W 16 point 3.6 W
Operating temperature range	7°C to 55°C (45°F to 131°F)
Storage temperature range	-40°C to 85°C (-40°F to 185°F)
Humidity	5 to 95%, non-condensing

<p>EMC Compliant</p> <p>Emissions</p> <p>Noise immunity</p>	<p>Operates with emissions below EN55011/ CISPR 11 Class A limits</p> <p>Immune to:</p> <ul style="list-style-type: none"> • Electrostatic discharge(4K V contact mode, 8K V air discharge) per IEC 1000-4-2 • RF electromagnetic fields per IEC 1000-4-3 • Electrical fast transients per IEC 1000-4-4 on incoming power lines <p>Refer to the EMC Guidelines for more information.</p>
<p>CE Marked</p>	<p>Conforms to Directives 73/23/EEC, 89/336/EEC, 92/31/EEC, 93/68/EEC by conforming to the following standards:</p> <p>EN 50081-2:1993 EMC Generic Industrial Emissions</p> <p>EN 50082-2:1995 EMC Generic Industrial Immunity</p> <p>EN 61131-2:1994/A11:1996 Low voltage directive requirements for programmable controllers</p> <p>Operates with emissions below EN5501/CISPR 11 Class A limits</p> <p>Immune to:</p> <ul style="list-style-type: none"> • Electrostatic discharge (4K V contact mode, 8K V air discharge) per EN61000-4-2 • RF electromagnetic fields per EN61100-4-3, ENV50141, and ENV50204
<p>UL and C/UL Listed</p>	<p>File No. E126417 NRAQ Programmable Controllers</p>
<p>Physical size</p>	<p>1.6" wide x 12" high x 8.4" deep (including latch)</p> <p>41 mm x 305 mm x 213 mm</p>
<p>Vibration (per IEC 68-2-6)</p>	<p>10-57 Hz (constant amplitude .15 mm)</p> <p>57-2000 Hz (acceleration 2 g)</p>
<p>Shock (per IEC 68-2-27)</p>	<p>Four shocks per axis (15g/11 msec)</p>

Input 24V DC Module (16 switch)

The input switch module converts the position status of 16 on/off switches mounted on the faceplate into logic levels that the CPU can use. The on/off position status of each switch is converted into a corresponding logic 1 or 0 which is transmitted through the system bus to the CPU module.

16 LEDs in the upper section of the module indicate the logic state of each switch input. The DIAG LED goes on briefly while the diagnostic tests are running.

INPUT Switch Module (16)

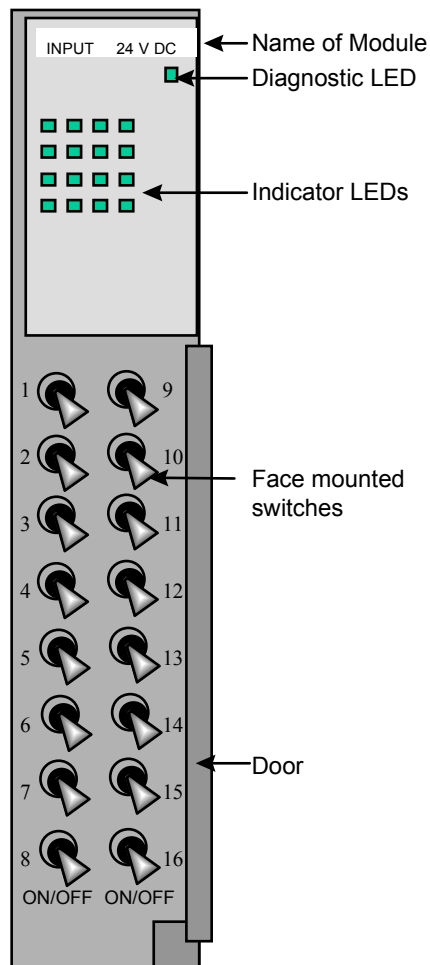

Specification Table

Characteristic	Input switch (16) module specifications
Function	Monitors on/off states from up to 16 face mounted switches
Part number	M.1016.9095 (old # 502-03651-00)
Field side connector	25-pin card edge connector, face plate, switches
Protection of logic circuits	Optical isolation between the logic and field sides
Indicator lights, input circuits	An LED indicates the logic state of each switch
Indicator light, module	The DIAG LED goes OFF when the module passes power-on diagnostic tests
Logic side power requirements (typical)	2 mA @ +5 V 11mA per energized input @ +5 V
Operating temperature range	7°C to 55°C (45°F to 131°F)
Storage temperature range	-40°C to 85°C (-40°F to 185°F)
Humidity	5 to 95%, non-condensing
EMC Compliant	
Emissions	Operates with emissions below EN55011/ CISPR 11 Class A limits
Noise immunity	Immune to: <ul style="list-style-type: none"> • Electrostatic discharge (4K V contact mode, 8K V air discharge) per IEC 1000-4-2 • RF electromagnetic fields per IEC 1000-4-3 • Electrical fast transients per IEC 1000-4-4 on incoming power lines
	Refer to the EMC Guidelines for more information.

Input 24V DC Module (16 switch)

CE Marked	<p>Conforms to Directives 73/23/EEC, 89/336/EEC, 92/31/EEC, 93/68/EEC by conforming to the following standards:</p> <p>EN 50081-2:1993 EMC Generic Industrial Emissions EN 50082-2:1995 EMC Generic Industrial Immunity EN 61131-2:1994/A11:1996 Low voltage directive requirements for programmable controllers</p> <p>Operates with emissions below EN5501/CISPR 11 Class A limits</p> <p>Immune to:</p> <ul style="list-style-type: none"> • Electrostatic discharge (4K V contact mode, 8K V air discharge) per EN61000-4-2 • RF electromagnetic fields per EN61100-4-3, ENV50141, and ENV50204
UL and C/UL Listed	File No. E126417 NRAQ Programmable Controllers
Physical size	1.6" wide x 12" high x 8.4" deep (including latch) 41 mm x 305 mm x 213 mm.
Vibration (per IEC 68-2-6)	10-57 Hz (constant amplitude .15 mm) 57-2000 Hz (acceleration 2 g)
Shock (per IEC 68-2-27)	Four shocks per axis (15g/11 msec)

Input 12V DC Module (32 points)

The input 12V DC module converts DC signals from 32 devices into logic levels that the CPU can use. Each signal is converted into a corresponding logic 1 or 0 which is transmitted through the system bus to the CPU module. An "on" signal is nominally 12 VDC, but can be any level between 10 and 14 volts. An "off" signal is any level below 5V. The wiring configurations may be sink or source.

32 LEDs in the upper section of the module indicate the logic state of each input. The DIAG LED goes on briefly while the diagnostics tests are running.

INPUT 12V DC Module (32 PT)

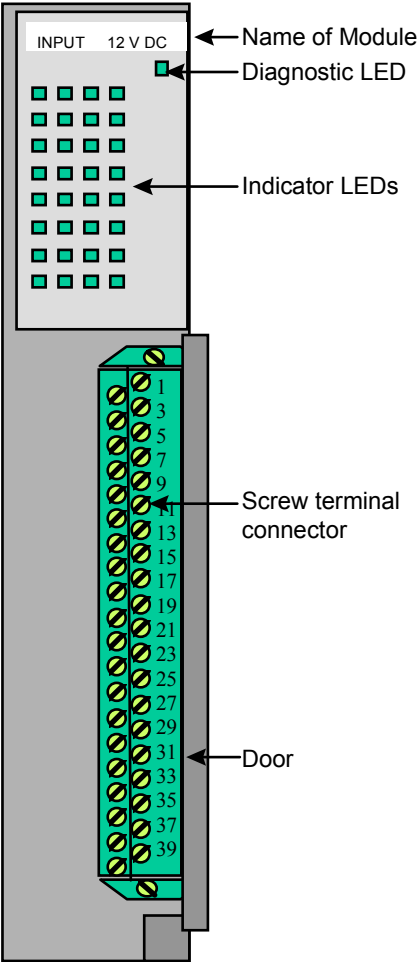

Specification Table

Characteristic	Input 12V DC (32 pt) module specifications
Function	Monitors on/off states from up to 32 DC voltage inputs
Part number	M.1016.9085 (old #502-03643-00)
Field side connector	40-pin card edge connector, screw terminals
Input signals	Nominal 12V DC on, 0V DC off
Maximum allowed voltage	14V DC
Maximum current @ 14V DC	8.5 mA
Guaranteed on	10V DC
Minimum current @ 10V DC	5 mA
Guaranteed off	5V DC
Current allowed when off	2 mA
Time delay on	1 ms max.
Time delay off	1 ms max.
Protection of logic circuits	Optical isolation between the logic and field sides, 4000 V peak
Input groups	Four groups of 8 inputs UL 508 spacing
Indicator lights, input circuits	An LED indicates the logic state of each input
Indicator light, module	The DIAG LED goes OFF when the module passes power-on diagnostic tests
Logic side power requirements (typical)	29 mA @ +5V 7 mA per energized input @ +5V
Field side power dissipation, worst case	3.8 W
Operating temperature range	7°C to 55°C (45°F to 131°F)
Storage temperature range	-40°C to 85°C (-40°F to 185°F)
Humidity	5 to 95%, non-condensing

<p>EMC Compliant</p> <p>Emissions</p> <p>Noise immunity</p>	<p>Operates with emissions below EN55011/ CISPR 11 Class A limits</p> <p>Immune to:</p> <ul style="list-style-type: none"> • Electrostatic discharge(4K V contact mode, 8K V air discharge) per IEC 1000-4-2 • RF electromagnetic fields per IEC 1000-4-3 • Electrical fast transients per IEC 1000-4-4 on incoming power lines <p>Refer to the EMC Guidelines for more information.</p>
<p>UL and C/UL Listed</p>	<p>File No. E126417 NRAQ Programmable Controllers</p>
<p>Physical size</p>	<p>1.6" wide x 12" high x 8.4" deep (including latch)</p> <p>41 mm x 305 mm x 213 mm</p>
<p>Vibration (per IEC 68-2-6)</p>	<p>10-57 Hz (constant amplitude .15 mm)</p> <p>57-2000 Hz (acceleration 2 g)</p>
<p>Shock (per IEC 68-2-27)</p>	<p>Four shocks per axis (15g/11 msec)</p>

Input 120V AC Module (16 points)

The 120V AC input module converts AC signals from 16 devices into logic levels that the CPU can use. Each signal is converted into a corresponding logic 1 or 0 which is transmitted through the system bus to the CPU module. An “on” signal is nominally 120V AC, but can be any level between 79 and 132 volts. An “off” signal is any level below 20 A C. The wiring configurations may be sink or source.

16 LEDs in the upper section of the module indicate the logic state of each input. The DIAG LED goes on briefly while the diagnostics tests are running.

INPUT 120V AC Module (16 PT)

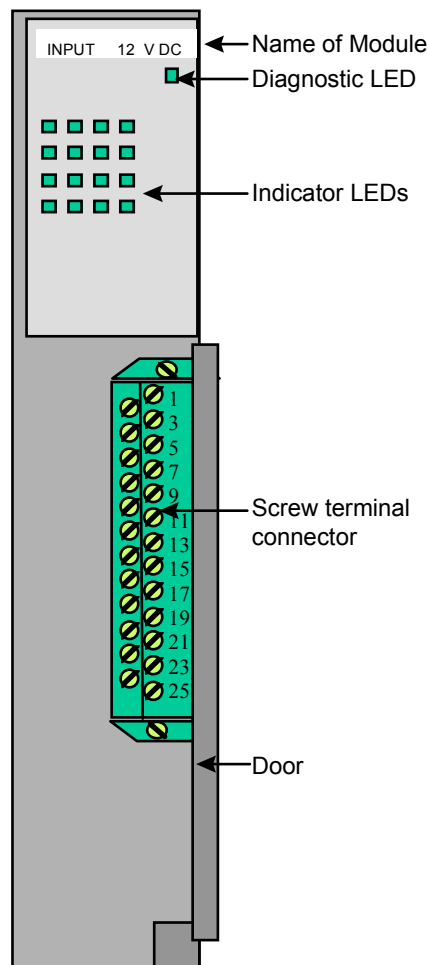

Specification Table

Characteristic	Input 120V AC (16 pt) Module Specifications
Function	Monitors on/off states from up to 16 AC voltage inputs
Part number	M.1016.8937 (old # 502-03550-02)
Field side connector	25-pin card edge connector, screw terminals
Input signals	Nominal 120V AC on, 0V AC off
UH Max (max. allowed voltage)	132V AC
IH Max (max. current @ 132V AC)	8.7 mA
UL Min	0V
Guaranteed on	79V AC
IH Min (min. current @ UH Min)	4.6 mA
Guaranteed off	20V AC
IT Min (current allowed when off)	1 mA
Frequency	50/60 Hz \pm 5%
Time delay on, max.	14 ms
Time delay off, max.	20 ms
Protection of logic circuits	Optical isolation between the logic and field sides, 1780 VAC.
Arrangement of inputs	Four groups of 4 IEC Type 1 inputs per NEMA Standard, ICS 3-1983, Table 3-304-2. UL 508 spacing
Indicator lights, circuits	An LED indicates its logic state of each input
Indicator light, module	The DIAG LED goes off after the module passes its diagnostic tests at power-on.
Logic side power requirements (typical)	1 mA @ +5V 11 mA per energized input @ +5V
Field side power dissipation, worst case	18.4 W
Operating temperature range	7°C to 55°C (45°F to 131°F)
Storage temperature range	-40°C to 85°C (-40°F to 185°F)
Humidity	5 to 95%, non-condensing

Input 120V AC Module (16 points)

EMC Compliant Emissions Noise immunity	Operates with emissions below EN55011/ CISPR 11 Class A limits Immune to: <ul style="list-style-type: none">• Electrostatic discharge (4K V contact mode, 8K V air discharge) per IEC 1000-4-2• RF electromagnetic fields per IEC 1000-4-3• Electrical fast transients per IEC 1000-4-4 on incoming power lines Refer to the EMC Guidelines for more information.
UL and C/UL Listed	File No. E126417 NRAQ Programmable Controllers
Physical size	1.6" wide x 12" high x 8.4" deep (including latch) 41 mm x 305 mm x 213 mm
Vibration (per IEC 68-2-6)	10-57 Hz (constant amplitude .15 mm) 57-2000 Hz (acceleration 2 g)
Shock (per IEC 68-2-27)	Four shocks per axis (15g/11 msec)

Output 24V DC Source Module (32 or 16 points)

The output 24V DC module sources voltage for individual loads from one or more DC power supplies. Each external supply is nominally 24 volts, but can be between 5 and 32 volts. It is available in the following configurations.

- 32 point 24V DC output module
- 16 point 24V DC output module

32 or 16 LEDs in the upper section of the module indicate the logic state that drives each output. Another LED labeled FB turns on if the fuse in any active circuit is open or missing.

The DIAG LED goes on briefly while the diagnostic tests are running.

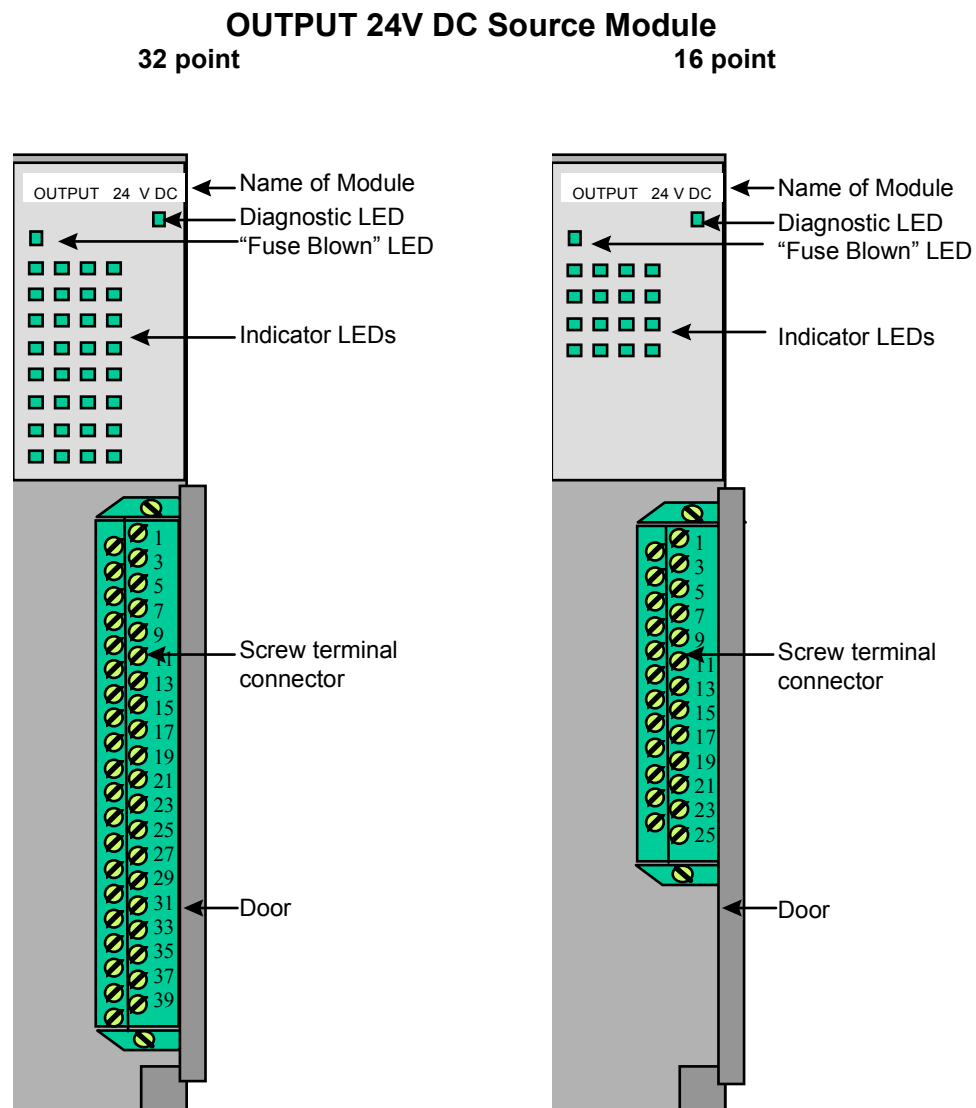

Specification Table

Characteristic	Output 24V DC module specifications
Function	Sources an external DC supply to 16/32 loads
Part number	32 point M.1016.9070 (old # 502-03640-02) 16 point M.1016.8933 (old # 502-03549-02)
DC source requirements	Nominal 24V DC; range 5 to 32V DC
Field side connector	32 point 40-pin card edge connector, screw terminals 16 point 25-pin card edge connector, screw terminals
Protection of logic circuits	Optical isolation between the logic and field side
Grouping of outputs	Four groups of 8 or 4 solid-state switches. Each group may use its own DC supply, or one supply may be daisy-chained. UL 508 spacing
Fuse per group of 8 switches	Fast-acting, UL rated 3 A 250V AC metric fuse, 5 x 20 mm
Maximum current per group	2 A of continuous current for the group; 32-point - each switch is rated at .4 A continuous 16 point - each switch is rated at .75 A continuous
Indicator lights, output circuits	An LED for each output
Indicator light, module	A DIAG LED turns OFF when the module passes its diagnostic tests at power-on
Indicator light, fuses	A logic side LED lights to indicate a "blown fuse" condition when power is on to a group with missing or open fuse
Switch characteristics	Solid-state switches
Time delay on for resistive loads	30 μ sec max
Time delay off for resistive loads	300 μ sec max
Leakage current in off state	0.5 mA max
Switch voltage, maximum ON	32 point 1.8V DC @ .4 A 16 point 1.6V DC @ .75 A
Surge current, maximum	32 point 2.5 A for 40 msec., every 2 seconds 16 point 5 A for 40 msec, every 2 seconds; fuse blows if this is exceeded
Response to scan loss (present)	All outputs are reset to the OFF state
Logic side power requirements (typical)	1 mA @ +5V 32 point 25 mA per energized output @ +5V 16 point 23 mA per energized output @ +5V
Field side power dissipation, worst case (at 32 VDC)	15.8 W
Operating temperature range	7°C to 55°C (45°F to 131°F)
Storage temperature range	-40°C to 85°C (-40°F to 185°F)

Humidity	5 to 95%, non-condensing
EMC Compliant Emissions Noise immunity	Refer to the EMC Guidelines for more information. Operates with emissions below EN55011/ CISPR 11 Class A limits Immune to: •Electrostatic discharge (4K V contact mode, 8K V air discharge) per IEC 1000-4-2 •RF electromagnetic fields per IEC 1000-4-3 •Electrical fast transients per IEC 1000-4-4 on incoming power lines
UL and C/UL Listed	File No. E126417 NRAQ Programmable Controllers
Physical size	1.6" wide x 12" high x 8.4" deep (including latch). 41 mm x 305 mm x 213 mm
Vibration (per IEC 68-2-6)	10-57 Hz (constant amplitude .15 mm) 57-2000 Hz (acceleration 2 g)
Shock (per IEC 68-2-27)	Four shocks per axis (15g/11 msec)

Output 24V DC Sink Module (3 versions)

The output 24V DC module sinks voltage for 32 individual loads from one or more DC power supplies. Each external supply is nominally 24 volts, but can be between 5 and 32 volts. It is available in three configurations:

- 32 point, all diode protected
- 32 point, 16 diode protected/16 unprotected
- 32 point, all unprotected

32 LEDs in the upper section of the module indicate the logic state that drives each output. Another LED labeled FB turns on if the fuse in any active circuit is open or missing.

The DIAG LED goes on briefly while the diagnostic tests are running.

OUTPUT 24V DC Source Module (32 pt)

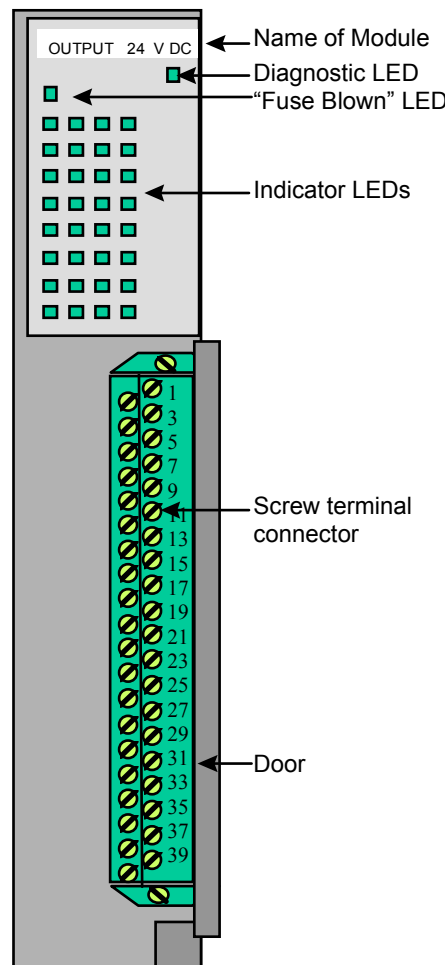

Specification Table

Characteristic	Output 24V DC module (32 pt sink) specifications
Function	Sinks an external DC source to 32 loads
Part number	16 protected/16 unprotected M.1016.9127 (old # 50203674-02) All diode protected M.1016.9130 (old # 502-03674-22) All unprotected M.1016.9133 (old # 502-03674-42)
DC source requirements	Nominal 24V DC; range 5 to 32V DC
Field side connector	40-pin card edge connector, screw terminals
Protection of logic circuits	Optical isolation between the logic and field side
Grouping of outputs	Four groups of 8 solid-state switches. Two groups share a DC supply. Two DC supplies are allowed per module. (One supply may be daisy chained.) UL 508 spacing
Fuse per group of 8 switches	Fast-acting, UL rated 3A 250V AC metric fuse, 5 x 20 mm
Maximum current per group	2 A of continuous current for the group; each switch is rated at .4 A continuous
Indicator lights, output circuits	An LED for each output
Indicator light, module	A DIAG LED turns OFF when the module passes its diagnostic tests at power-on
Indicator light, fuses	A logic side LED lights to indicate a "blown fuse" condition when power is on to a group with missing or open fuse
Switch characteristics	Solid-state switches
Time delay on for resistive loads	30 μ sec max
Time delay off for resistive loads	300 μ sec max
Leakage current in off state	0.5 mA max
Switch voltage, maximum ON	1.8V DC @ .4 A
Surge current, maximum	2.5 A for 40 msec., every 2 seconds
Response to scan loss (present)	All outputs are reset to the OFF state.
Logic side power requirements (typical)	1 mA @+5V 25 mA per energized output @ +5V
Field side power dissipation, worst case (at 32 VDC)	15.8 W

Output 24V DC Sink Module (3 versions)

Operating temperature range	7°C to 55°C (45°F to 131°F)
Storage temperature range	-40°C to 85°C (-40°F to 185°F)
Humidity	5 to 95%, non-condensing
EMC Compliant Emissions Noise immunity	Operates with emissions below EN55011/ CISPR 11 Class A limits Immune to: <ul style="list-style-type: none"> • Electrostatic discharge (4K V contact mode, 8K V air discharge) per IEC 1000-4-2 • RF electromagnetic fields per IEC 1000-4-3 • Electrical fast transients per IEC 1000-4-4 on incoming power lines Refer to the EMC Guidelines for more information.
UL and C/UL Listed	File No. E126417 NRAQ Programmable Controllers
Physical size	1.6" wide x 12" high x 8.4" deep (including latch). 41 mm x 305 mm x 213 mm
Vibration (per IEC 68-2-6)	10-57 Hz (constant amplitude .15 mm) 57-2000 Hz (acceleration 2 g)
Shock (per IEC 68-2-27)	Four shocks per axis (15g/11 msec)

Output Relay Module (8 points)

The relay output module can switch eight relay contacts. Four relays are normally open(NO)/normally closed(NC) form C type and four are normally open (NO) form A type.

Eight LEDs in the upper section of the module indicate the logic state that drives each relay.

The DIAG LED goes on briefly while the diagnostic tests are running.

OUTPUT RELAY Module (8 PT)

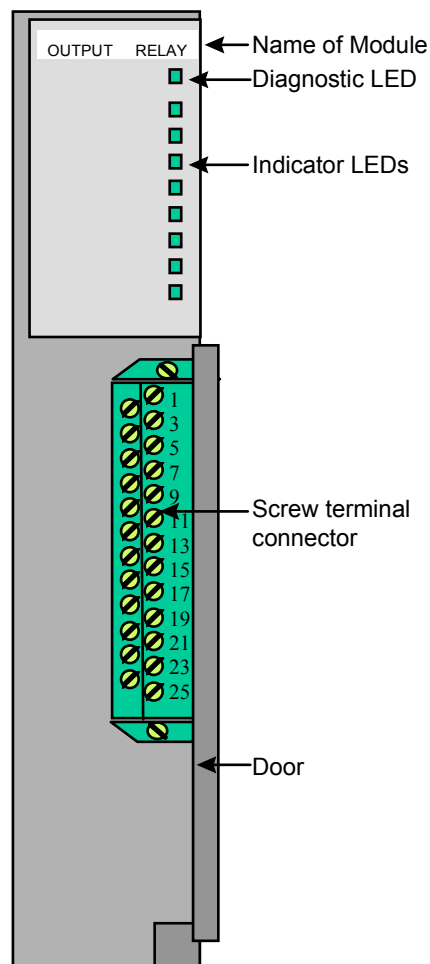

Specification Table

Characteristic	Output relay (8) module specification
Function	Switches eight relay contacts
Part number	M.1016.9089 (old # 502-03644-03)
Field side connector	25 pin card edge connector, screw terminals
Output channels	8
Relay characteristics Contact types	Four form C (NO/NC) Four form A (NO)
Maximum switching voltage	280V AC resistive load; 50V DC resistive load
Minimum switching current	100 mA
Maximum switching current (DC)	0-24V DC @ 3 A 30 VDC @ 2.5 A 40V DC @ 1.5 A 50 VDC @ 1.0 A
Maximum switching current (AC)	0-120V AC @ 3 A 280V AC @ 2.5 A
Initial contact resistance	100 m ³ / ₄
Turn on time (resistive load)	10 msec maximum
Turn off time (resistive load)	10 msec maximum
Expected life, electrical	10 ⁵ operations minimum
Expected life, mechanical	10 ⁷ operations minimum
Breakdown voltage between contacts	750 V _{rms} for 1 minute
Breakdown voltage between contacts and coil	1500 V _{rms} for 1 minute
Maximum switching frequency	20 energize/deenergize cycles/min. (to satisfy expected life ratings)
Indicator light, module	DIAG LED turns off after the module passes its diagnostic tests. A logic side LED for each relay turns on when the logic side energizes the relay.
Isolation	Electromechanical relay provides protection between logic and field side
Logic side power requirements (typical)	1 mA @ 5V 5 mA @ +15V 39 mA per energized output @ +15V (Pt 1-4) 24 mA per energized output @ +15V (Pt 5-8)

Operating temperature range	7°C to 55 C (45°F to 131°F)
Storage temperature range	-40°C to 85°C (-40°F to 185°F)
Humidity	5 to 95%, non-condensing
EMC Compliant Emissions Noise immunity	Refer to the EMC Guidelines for more information. Operates with emissions below EN55011/ CISPR 11 Class A limits Immune to: <ul style="list-style-type: none"> • Electrostatic discharge (4K V contact mode, 8K V air discharge) per IEC 1000-4-2 • RF electromagnetic fields per IEC 1000-4-3 • Electrical fast transients per IEC 1000-4-4 on incoming power lines
UL and C/UL Listed	File No. E126417 NRAQ Programmable Controllers
Physical size	1.6" wide x 12" high x 8.4" deep (including latch) 41 mm x 305 mm x 213 mm
Vibration (per IEC 68-2-6)	10-57 Hz (constant amplitude .15 mm) 57-2000 Hz (acceleration 2 g)
Shock (per IEC 68-2-27)	Four shocks per axis (15g/11 msec)

Output 120/240V AC Module (32 or 16 points)

The 120/240V output module switches voltage for individual loads from one or more AC power sources. Each external AC source is nominally 115 VAC, but can be between 48 and 240 volts. It is available in the following configurations:

- 32 point 120/240V AC output module
- 16 point 120/240V AC output module

32 or 16 LEDs in the upper section of the module indicate the logic state that drives each output. Another LED labeled FB turns on if the fuse in any active circuit is open or missing.

The DIAG LED goes on briefly while the diagnostic tests are running.

OUTPUT 120/240 VAC Module

32 point

16 point

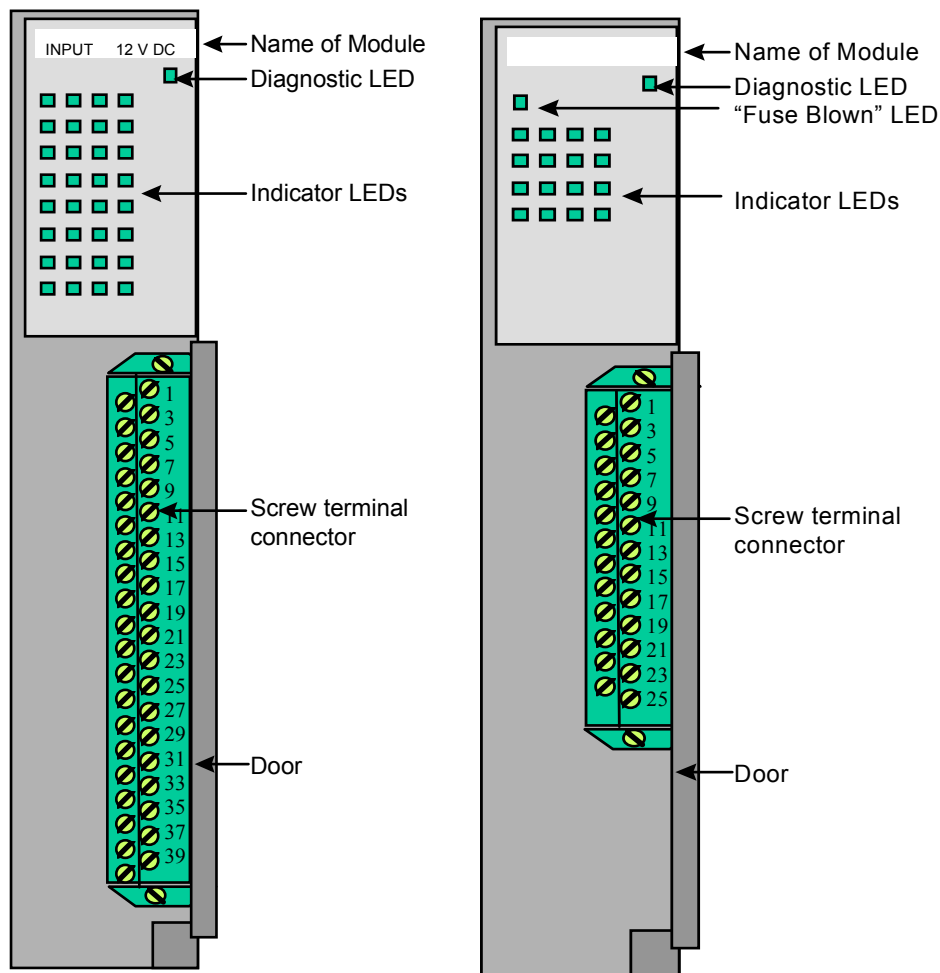

Specification Table

Characteristic	Output 120/240V AC module specifications
Function	Switches an external AC source to 32 or 16 loads
Part number	32 point M.1016.9076 (old # 502-03641-03) 16 point M.1016.8943 (old # 502-03551-03)
AC source requirements	Nominal 115 VAC, range 48 to 240V AC
Field side connector	32 point 40-pin card edge connector, screw terminals 16 point 25-pin card edge connector, screw terminals
Protection of logic circuits	Optical isolation between the logic and field side, 2830 V AC
Arrangement of outputs	Four groups of 8 or 4 solid-state switches. Each group can use its own AC source, or one source can be daisy-chained. UL 508 spacing
Fuse per group of 8	Fast-acting, UL rated 3A 250V AC metric fuse, 5 x 20 mm
Maximum current per group	2 A of continuous current for the group; 32 point each switch is rated at .75 A continuous 16 point each switch is rated at 2 A continuous
Indicator lights, output circuits	An LED for each output
Indicator light, module	A DIAG LED turns OFF when the module passes its diagnostic tests at power-on.
Indicator light, fuses	A logic side LED lights to indicate a "blown fuse" condition when power is on to a group with a missing or open fuse.
Switch characteristics	Solid-state switches.
Switch voltage, maximum ON	32 point 1V AC @ .75A RMS 16 point 1.2V AC @ 2A RMS
Surge current, maximum	20 A for 2 cycles, every 2 seconds; fuse blows if this is exceeded.
Frequency	50 / 60 Hz. \pm 5%
Time delay on, maximum	1/2 cycle (turns on at zero voltage)
Time delay off, maximum	1/2 cycle (turns off at zero voltage)
Minimum load current	50 mA
Leakage current in OFF state, max	4 mA @ 120 VAC 6 mA @ 240V AC
Response to scan loss (present)	All outputs are reset to the OFF state
Logic side power requirements (typical)	32 point 1 mA @ +5V 7 mA per energized output @ +5V 16 point 1 mA @ +5V 23 mA per energized output @ +5V

Output 120/240V AC Module (32 or 16 points)

Field side power dissipation, worst case	32 point 11.0 W 16 point 12.0 W
Operating temperature range	7°C to 55°C (45°F to 131°F)
Storage temperature range	-40° C to 85°C (-40°F to 185°F)
Humidity	5 to 95%, non-condensing
EMC Compliant Emissions Noise immunity	Operates with emissions below EN55011/ CISPR 11 Class A limits Immune to: <ul style="list-style-type: none"> • Electrostatic discharge (4K V contact mode, 8K V air discharge) per IEC 1000-4-2 • RF electromagnetic fields per IEC 1000-4-3 • Electrical fast transients per IEC 1000-4-4 on incoming power lines Refer to the EMC Guidelines for more information.
UL and C/UL Listed	File No. E126417 NRAQ Programmable Controllers
Physical size	1.6" wide x 12" high x 8.4" deep (including latch) 41 mm x 305 mm x 213 mm
Vibration (per IEC 68-2-6)	10-57 Hz (constant amplitude .15 mm) 57-2000 Hz (acceleration 2 g)
Shock (per IEC 68-2-27)	Four shocks per axis (15g/11 msec)

Input/Output TTL Module (24 inputs/8 outputs)

The TTL (Transistor-Transistor Logic) module provides 24 optically isolated input points to monitor the status of TTL devices and 8 optically isolated output points to interface with TTL devices (or other 5V DC devices such as photoelectric sensors).

The module can also be used as a feedback module to read devices like linear displacement transducers (TEMPOSONICS™, BALLUFF) or absolute encoders. These devices provide high speed, low voltage, low noise parallel digital signals.

An external +5V DC is required for operation.

The DIAG LED goes on briefly while the diagnostic tests are running.

TTL (24 inputs/8 outputs)

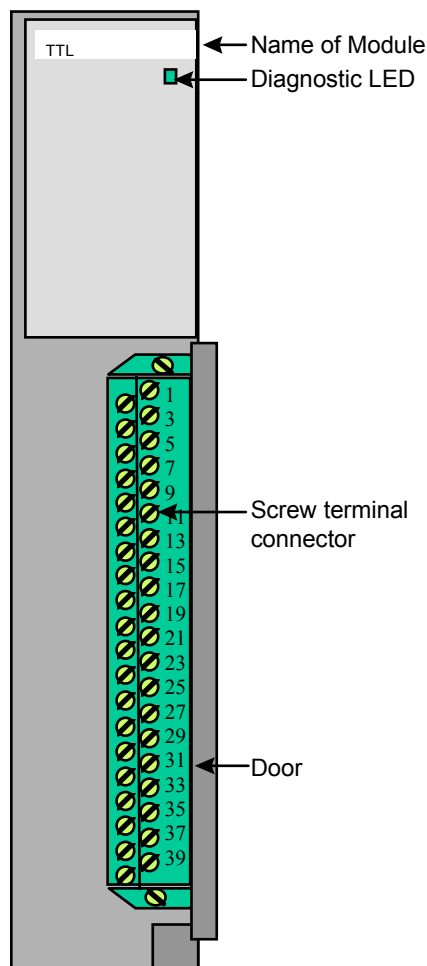

Specification Table

Characteristics	TTL module specifications
Function	Monitors on/off states of 24 TTL inputs and controls on/off state of 8 TTL outputs.
Part number	M.1016.9291 (old # 502-03810-03)
Field side connector	40 pin card edge connector, screw terminals
External power supply	+5V \pm 5% 450 mA
Isolation	2500 VRMS between field side and logic side
Input characteristics	V_{in} high- 2.0 V minimum V_{in} low- 0.8 V maximum I_{in} high- 1 μ A maximum I_{in} low - -0.65 mA maximum Minimum input pulse width 1 μ sec
Output characteristics	V_{ol} -0.8V maximum @ $I_o = 10$ mA (sinking) V_{oh} -4.0V minimum @ $I_o = -10$ mA (sourcing) Output turn on/off time - 300 nano sec Maximum cable length - 3 meters (approximately 10 feet)
Logic side power requirements (typical)	+5V @ 450 mA
Operating temperature range	7°C to 55°C (45°F to 131°F)
Storage temperature range	-40°C to 85°C (-40°F to 185°F)
Humidity	5 to 95%, non-condensing

<p>EMC Compliant</p> <p>Emissions</p> <p>Noise immunity</p>	<p>Operates with emissions below EN55011/ CISPR 11 Class A limits</p> <p>Immune to:</p> <ul style="list-style-type: none"> • Electrostatic discharge (4K V contact mode, 8K V air discharge) per IEC 1000-4-2 • RF electromagnetic fields per IEC 1000-4-3 • Electrical fast transients per IEC 1000-4-4 on incoming power lines <p>Refer to the EMC Guidelines for more information.</p>
<p>UL and C/UL Listed</p>	<p>File No. E126417 NRAQ Programmable Controllers</p>
<p>Physical size</p>	<p>1.6" wide x 12" high x 8.4" deep (including latch) 41 mm x 305 mm x 213 mm</p>
<p>Vibration (per IEC 68-2-6)</p>	<p>10-57 Hz (constant amplitude .15 mm) 57-2000 Hz (acceleration 2 g)</p>
<p>Shock (per IEC 68-2-27)</p>	<p>Four shocks per axis (15g/11 msec)</p>

Input/Output 24V DC Sink Module (16/8 points)

The input section of the 24V DC I/O module converts DC signals from 16 devices into logic levels that the CPU can use. Each signal is converted into a corresponding logic 1 or 0 which is transmitted through the system bus to the CPU. An "on" signal is nominally 24 VDC, but can be any level between 14 and 30 volts. An "off" signal is any level below 5V. The wiring configurations may be sink or source. 16 LEDs indicate the logic state of each input.

The output section of the module sinks voltage for eight individual loads from one DC power supply. The external supply is nominally 24 volts, but can be between 5 and 32 volts. Eight LEDs on the module indicate the logic state that drives each output. Another LED labeled FB turns on if the fuse in the active circuit is open or missing.

The DIAG LED goes on briefly while the diagnostics tests are running.

24V DC Input/Output Module (16/8 sink pt)

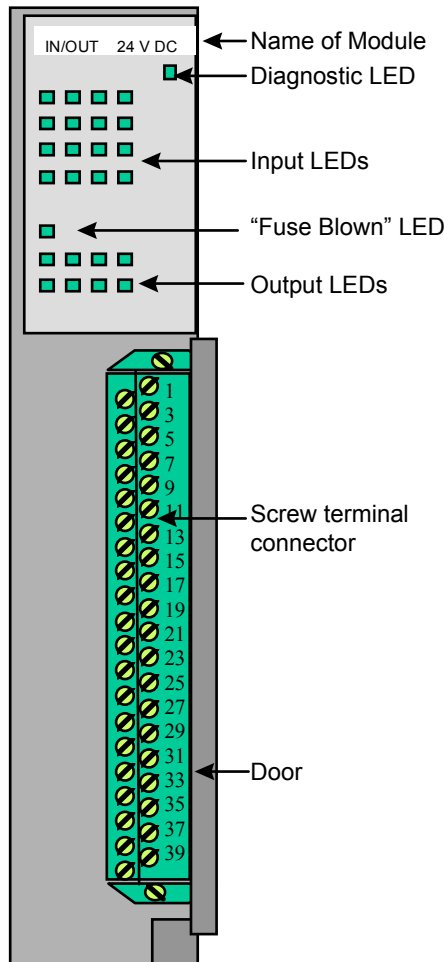

Specification Table

Characteristic	Module specifications
Function	Monitors on/off states from up to 16 DC voltage inputs Sinks an external DC source to eight loads
Part number	M.1016.9350 (old # 502-03843-02)
Field side connector	40-pin card edge connector, screw terminals
Logic side power requirements (typical)	30 mA @ 5 V 7 mA per energized input @ +5 V 25 mA per energized output @ +5 V
Field side power dissipation (worst case at 32V DC)	3.6 W for inputs 4.0 W for outputs
Indicator lights, input/output circuits	An LED for each input/output
Indicator light, module	A DIAG LED turns OFF when the module passes its diagnostic tests at power-on
Indicator light, fuses	A logic side LED lights to indicate a "blown fuse" condition when power is on to the eight outputs when a fuse is missing or open
Operating temperature range	7°C to 55°C (45°F to 131°F)
Storage temperature range	-40°C to 85°C (-40°F to 185°F)
Humidity	5 to 95%, non-condensing
EMC Compliant Emissions Noise immunity	Operates with emissions below EN55011/ CISPR 11 Class A limits Immune to: <ul style="list-style-type: none"> • Electrostatic discharge (4K V contact mode, 8K V air discharge) per IEC 1000-4-2 • RF electromagnetic fields per IEC 1000-4-3 • Electrical fast transients per IEC 1000-4-4 on incoming power lines Refer to the EMC Guidelines for more information.
UL and C/UL Listed	File No. E126417 NRAQ Programmable Controllers
Physical size	1.6" wide x 12" high x 8.4" deep (including latch). 41 mm x 305 mm x 213 mm
Vibration (per IEC 68-2-6)	10-57 Hz (constant amplitude .15 mm) 57-2000 Hz (acceleration 2 g)
Shock (per IEC 68-2-27)	Four shocks per axis (15g/11 msec)

Input/Output 24V DC Sink Module (16/8 points)

Input section(16 pt)	
Input signals (exceed IEC standards)	Nominal 24V DC on, 0V DC off
UH Max (max. allowed voltage)	30V DC
IH Max (max. current @ 30 VDC)	7.5 mA
UL Min	Polarity independent
Guaranteed on	14V DC
IH Min (min. current @ UH Min)	2.8 mA
Guaranteed off	5V DC
IT Min (current allowed when off)	.75 mA
Time delay on	.75 mA
Time delay off	1 ms max
Protection of logic circuits	Optical isolation between the logic and field sides 4000 V peak
Input groups	Two groups of 8 IEC Type 1 inputs per NEMA Standard, ICS 3-1983, Table 3-304-2. UL 508 spacing
Output section (8 pt sink)	
DC source requirements	Nominal 24V DC; range 5 to 32V DC
Protection of logic circuits	Optical isolation between the logic and field side
Grouping of output	One grup of 8 solid-state switches UL 508 spacing
Fuse per group of 8 switches	Fast-acting UL rated 3 A 250V AC metric fuse, 5 x 20 mm
Maxiumum current per group	2 A of continuous current for the group; each switch is rated at .4 A continuous
Switch characteristics	Solid-state switches
Time delay on for resistive loads	30 µsec max
Time delay off for resistive loads	300 µsec max
Leakage current in off state	0.5 mA max
Switch voltage, maxiumum ON	1.8 VDC@ .4A
Surge current, maxiumum	2.5 A for 40 msec., every 2 seconds
Response to scan loss (present)	All outputs are reset to the OFF state

Input/Output 24V DC Source Module (16/8 points)

The input section of the 24V DC I/O module converts DC signals from 16 devices into logic levels that the CPU can use. Each signal is converted into a corresponding logic 1 or 0 which is transmitted through the system bus to the CPU. An “on” signal is nominally 24V DC, but can be any level between 14 and 30 volts. An “off” signal is any level below 5V. The wiring configurations may be sink or source. 16 LEDs on the module indicate the logic state of each input.

The output section of the module sources voltage for eight individual loads from one or two DC power supplies. Each external supply is nominally 24 volts, but can be between 5 and 32 volts. Eight LEDs indicate the logic state that drives each output. Another LED labeled FB turns on if the fuse in any active circuit is open or missing.

The DIAG LED goes on briefly while the diagnostics tests are running.

24V DC input/output module (16/8 source PT)

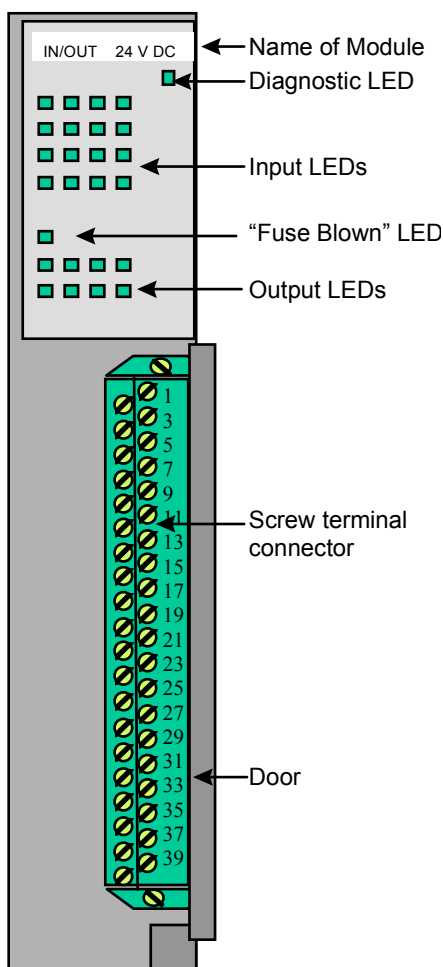

Specification Table

Characteristic	Input/Output module specifications
Function	Monitors on/off states from up to 16 DC voltage inputs Sources an external DC source to 8 loads
New Part number	M.1016.9348 (old # 502-03842-02)
Field side connector	40-pin card edge connector, screw terminals
Logic side power requirements (typical)	30 mA @ +5V 7 mA per energized input @ +5V 23 mA per energized output @ +5V for outputs
Field side power dissipation worst case (at 32V DC)	3.6 W for inputs 6.4 W for outputs
Indicator lights, input/output circuits	An LED indicates the logic state of each input/output
Indicator light, module	The DIAG LED goes OFF when the module passes power-on diagnostic tests
Indicator light, fuses	A logic side LED lights to indicate a "blown fuse" condition when power is on to a group with missing or open fuse
Operating temperature range	7°C to 55°C (45°F to 131°F)
Storage temperature range	-40°C to 85°C (-40°F to 185°F)
Humidity	5 to 95%, non-condensing
EMC Compliant Emissions Noise immunity	Operates with emissions below EN55011/ CISPR 11 Class A limits Immune to: <ul style="list-style-type: none"> • Electrostatic discharge (4K V contact mode, 8K V air discharge) per IEC 1000-4-2 • RF electromagnetic fields per IEC 1000-4-3 • Electrical fast transients per IEC 1000-4-4 on incoming power lines Refer to the EMC Guidelines for more information.
UL and C/UL Listed	File No. E126417 NRAQ Programmable Controllers
Physical size	1.6" wide x 12" high x 8.4" deep (including latch). 41 mm x 305 mm x 213 mm
Vibration (per IEC 68-2-6)	10-57 Hz (constant amplitude .15 mm) 57-2000 Hz (acceleration 2 g)
Shock (per IEC 68-2-27)	Four shocks per axis (15g/11 msec)

Input section(16 pt)	
Input signals (exceed IEC standards)	Nominal 24 VDC on, 0 VDC off
UH Max (max. allowed voltage)	30V DC
IH Max (max. current @ 30 VDC)	7.5 mA
UL Min	Polarity independent
Guaranteed on	14V DC
IH Min (min. current @ UH Min)	2.8 mA
Guaranteed off	5V DC
IT Min (current allowed when off)	.75 mA
Time delay on	1 ms max.
Time delay off	1 ms max.
Protection of logic circuits	Optical isolation between the logic and field sides, 4000 V peak
Input groups	Two groups of 8 IEC Type 1 inputs per NEMA Standard, ICS 3-1983, Table 3-304-2. UL 508 spacing
Output section (8 pt source)	
DC source requirements	Nominal 24V DC; range 5 to 32 VDC
Protection of logic circuits	Optical isolation between the logic and field side
Grouping of outputs	Two groups of four solid-state switches. UL 508 spacing
Fuse per group of 8 switches	Fast-acting, UL rated 3A 250 VAC metric fuse, 5 x 20 mm
Maximum current per group	2 A of continuous current for the group; each switch is rated at .75 A continuous
Switch characteristics	Solid-state switches
Time delay on for resistive loads	30 µsec max
Time delay off for resistive loads	300 µsec max
Leakage current in off state	0.5 mA max
Switch voltage, maximum ON	1.8V DC @ .4 A
Surge current, maximum	2.5 A for 40 msec., every 2 seconds
Response to scan loss (present)	All outputs are reset to the OFF state

Input/Output 24V DC Source Module (16/8 points)

**PiC900 CONTROLS
MOTION SOLUTIONS PRODUCT GUIDE**

PiC 900 Analog Modules

Giddings & Lewis

Analog Input Module (8 channel)

The analog input module is designed to interface the PiC with voltage or current output devices to monitor such things as pressure, flow, speed, position, or temperature. There are two versions of the analog input module available. One has 12-bit resolution and the other has 14-bit resolution.

The module has eight independent analog conversion channels. Each channel converts a unipolar or bipolar analog input voltage or current into a 12- or 14- bit digital value. This data is transmitted to the PiCs CPU for processing.

There is an internal current sense resistor for each channel for use with 0 to 20 mA or 4 to 20 mA devices. This module contains no user adjustable potentiometers or hardware switches. All necessary gain adjustments are done in software. The analog module can be configured as a feedback module using the Servosetup software.

The DIAG LED goes on briefly while the diagnostics tests are running.

INPUT ANALOG Module (8 CH)

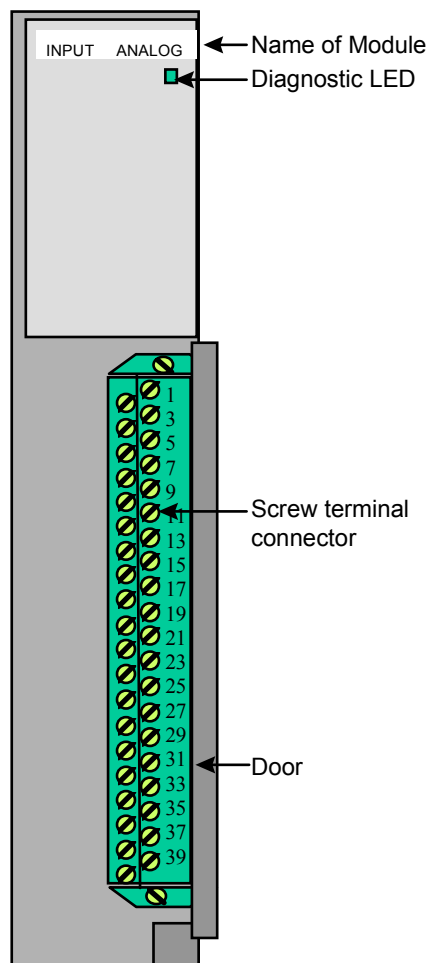

Specification Table

Characteristic	Input Analog (8 ch) module specification																		
Function	Converts an analog input signal into a 12- or 14-bit digital word for each of eight channels.																		
Part number	12-bit M.1016.9081 (old # 502-03642-03) 14-bit M.1016.9544 (old # 502-04050-00)																		
Field side connector	40 pin card edge connector, screw terminals																		
Input channels	8																		
Resolution	12 bits, or 4096 steps over the full input range 14 bits, or 16384 steps over the full input range																		
Input sensitivity (software selectable)																			
Voltage ranges	<table border="0"> <thead> <tr> <th>Unipolar</th> <th>Bipolar</th> </tr> </thead> <tbody> <tr> <td>0 to 10V</td> <td>±10V</td> </tr> <tr> <td>0 to 5V</td> <td>±5V</td> </tr> <tr> <td>0 to 2.5V</td> <td>±2.5V</td> </tr> <tr> <td>0 to 1.25V</td> <td>±1.25V</td> </tr> <tr> <td>0 to 1V</td> <td>±1V</td> </tr> <tr> <td>0 to .5V</td> <td>±.5V</td> </tr> <tr> <td>0 to .25V</td> <td>±.25V</td> </tr> <tr> <td>0 to .125V</td> <td>±.125V</td> </tr> </tbody> </table>	Unipolar	Bipolar	0 to 10V	±10V	0 to 5V	±5V	0 to 2.5V	±2.5V	0 to 1.25V	±1.25V	0 to 1V	±1V	0 to .5V	±.5V	0 to .25V	±.25V	0 to .125V	±.125V
Unipolar	Bipolar																		
0 to 10V	±10V																		
0 to 5V	±5V																		
0 to 2.5V	±2.5V																		
0 to 1.25V	±1.25V																		
0 to 1V	±1V																		
0 to .5V	±.5V																		
0 to .25V	±.25V																		
0 to .125V	±.125V																		
Current range	0 to 20 mA, 4 to 20 mA																		
Common mode maximum voltage (The maximum voltage that can safely be applied between either input terminal and circuit common.)	±40V																		
Common mode operating voltage (The maximum voltage that can be applied between either input terminal and circuit common with inputs still operating properly.)	±11V																		
Internal current sense resistor	250 ohms																		
Maximum current sense resistor power	.12 W																		
Differential input resistance (each input to ground)	1 M Ohms																		
Filter time constant - software selection	1 ms, 10 ms, 100 ms																		

Accuracy of 4-20 mA range	12-bit - .2% of FSR at 25°C 14-bit - .15% of FSR at 25°C ± 100 PPM /°C
Accuracy of all other ranges	12-bit - .5% of FSR at 25°C 14-bit - .2% of FSR at 25°C ± 100 PPM /°C
0 Offset	12-bit-from ±2 counts @ 10 V to ±8 counts @ .125 14-bit-from ±5 counts @ 10 V to ±40 counts @ .125
Logic side power requirements (typical)	120 mA @ +5 V 112 mA @ +15 V
Indicator light, module	DIAG LED goes off after the module passes its diagnostic tests
Operating temperature range	7°C to 55°C (45°F to 131°F)
Storage temperature range	-40°C to 85°C (-40°F to 185°F)
Humidity	5 to 95%, non-condensing
EMC Compliant Emissions Noise immunity	Operates with emissions below EN55011/ CISPR 11 Class A limits Immune to: <ul style="list-style-type: none"> • Electrostatic discharge (4K V contact mode, 8K V air discharge) per IEC 1000-4-2 • RF electromagnetic fields per IEC 1000-4-3 • Electrical fast transients per IEC 1000-4-4 on incoming power lines Refer to the EMC Guidelines for more information.
UL and C/UL Listed	File No. E126417 NRAQ Programmable Controllers
Physical size	1.6" wide x 12" high x 8.4" deep (including latch) 41 mm x 305 mm x 213 mm
Vibration (per IEC 68-2-6)	10-57 Hz (constant amplitude .15 mm) 57-2000 Hz (acceleration 2 g)
Shock (per IEC 68-2-27)	Four shocks per axis (15g/11 msec)

NOTES

Analog Output $\pm 10V$ DC Module (8, 4 channel)

The $\pm 10V$ DC output module has eight or four independent D/A conversion channels. It is also called a D/A or Analog Output module. Each channel converts a 16-bit digital word into a differential type analog output signal. The full range of the output signal is -11 V to +11 V, with a resolution of 1 part in 65,536.

A typical use for this module is to supply the velocity command to a servo drive. This module contains no potentiometers or hardware switches. All necessary adjustments are done using PiCServoPro/PiCPro commands.

The DIAG LED goes on briefly while the diagnostics tests are running.

OUTPUT $\pm 10V$ DC Module (8, 4 CH)

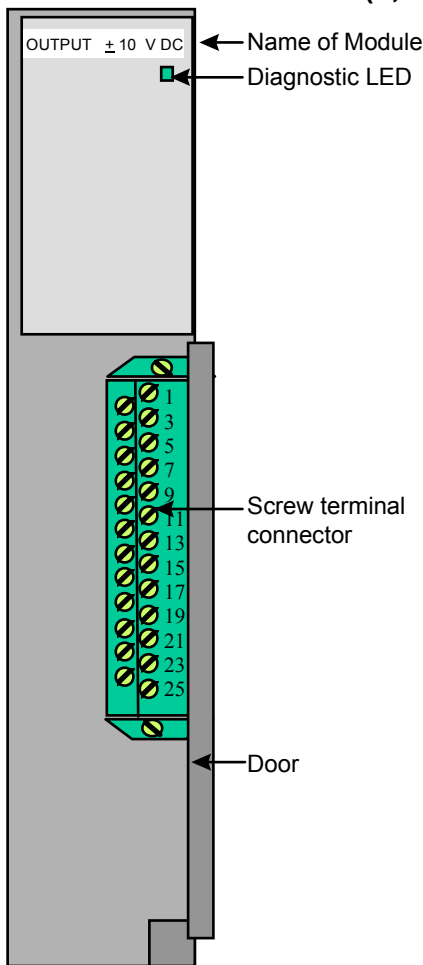

Specification Table

Characteristic	Output ± 10 VDC module specification
Function	Converts a 16-bit digital word into a +/- 11 V analog signal for each of eight or four channels.
Part number	8 ch M.1016.8892 (old # 502-03518-03) 4 ch M.1016.8897 (old # 502-03518-23)
Field side connector	25 pin card edge connector, screw terminals
Output channels	8 4
Resolution	16 bits, or 65536 steps over the full output range
Output voltage characteristics	
Nominal voltage range	$\pm 11V$ DC
Voltage accuracy @ 11 V	$\pm 5\%$
Output current, max. @ $\pm 10V$	± 10 mA
Output update time increment	32 μ s
Output voltage after power up	0 V \pm 20 mV
Response to scan loss	All outputs reset to 0V \pm 20 mV
Output ripple	< 10 mV _{RMS} at 30 KHz
Short circuit protection	Current limited outputs
Indicator light, module	DIAG LED goes off after the module passes its diagnostic tests
Logic side power requirements (typical)	For 8 channel module; 43 mA @ +5V 11 mA @ +15V 6 mA @ -15V 2 mA per energized output @ +5V 12 mA per energized output @ +15V 12 mA per energized output @ -15V For 4 channel module; 37 mA @ +5V 5 mA @ +15V 3 mA @ -15V 1 mA per energized output @ +5V 11 mA per energized output @ +15V

Operating temperature range	7°C to 55°C (45°F to 131°F)
Storage temperature range	-40°C to 85°C (-40°F to 185°F)
Humidity	5 to 95%, non-condensing
EMC Compliant Emissions Noise immunity	Operates with emissions below EN55011/ CISPR 11 Class A limits Immune to: <ul style="list-style-type: none"> • Electrostatic discharge (4K V contact mode, 8K V air discharge) per IEC 1000-4-2 • RF electromagnetic fields per IEC 1000-4-3 • Electrical fast transients per IEC 1000-4-4 on incoming power lines Refer to the EMC Guidelines for more information.
UL and C/UL Listed	File No. E126417 NRAQ Programmable Controllers
Physical size	1.6" wide x 12" high x 8.4" deep (including latch) 41 mm x 305 mm x 213 mm
Vibration (per IEC 68-2-6)	10-57 Hz (constant amplitude .15 mm) 57-2000 Hz (acceleration 2 g)
Shock (per IEC 68-2-27)	Four shocks per axis (15g/11 msec)

NOTES

Analog Input $\pm 10V$ Output (4 Channel)

The module provides:

- Four analog input channels
- Four analog output channels

The DIAG LED goes on briefly while the diagnostic tests are running.

Analog In/ $\pm 10V$ Out module

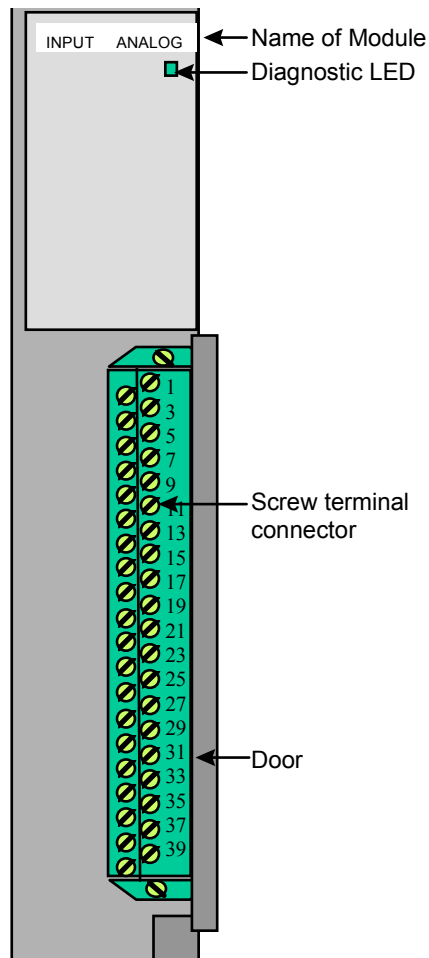

Specification Table

Characteristic	Analog In/ $\pm 10V$ Out module specifications
Function	Converts a 16-bit digital word into a $\pm 11V$ analog output signal for each of four channels Converts an analog input signal into a 12-bit digital word for each of four channels.
New Part number	M.1016.9408 (old # 502-03907-03)
Logic side power requirements (typical)	192 mA @ +5V 70 mA @ +15V 53 mA @ -15V Analog Output 1 mA per energized output @ +5V 11 mA per energized output @ +15V 11 mA per energized output @ -15V
Field side connection	40 pin card edge connector, screw terminals
Indicator light, module	DIAG LED goes off after the module passes its diagnostic tests
Operating temperature range	7°C to 55°C (45°F to 131°F)
Storage temperature range	-40°C to 85°C (-40°F to 185°F)
Humidity	5 to 95%, non-condensing
EMC Compliant Emissions Noise immunity	Operates with emissions below EN55011/ CISPR 11 Class A limits Immune to: <ul style="list-style-type: none"> • Electrostatic discharge (4K V contact mode, 8K V air discharge) per IEC 1000-4-2 • RF electromagnetic fields per IEC 1000-4-3 • Electrical fast transients per IEC 1000-4-4 on incoming power lines Refer to the EMC Guidelines for more information.
UL and C/UL Listed	File No. E126417 NRAQ Programmable Controllers
Physical size	1.6" wide x 12" high x 8.4" deep (including latch) 41 mm x 305 mm x 213 mm
Vibration (per IEC 68-2-6)	10-57 Hz (constant amplitude .15 mm) 57-2000 Hz (acceleration 2 g)
Shock (per IEC 68-2-27)	Four shocks per axis (15g/11 msec)

Analog Output section (4 ch)																			
Output channels	4																		
Resolution	16 bits, or 65536 steps over the full output range																		
Output voltage characteristics																			
Nominal voltage range	$\pm 11V$ DC																		
Voltage accuracy @ 11 V	$\pm 5\%$																		
Output current, max. @ $\pm 10V$	± 10 mA																		
Output update time increment	32 μ sec																		
Output voltage after power up	0 V ± 20 mV																		
Response to scan loss	All outputs reset to 0 V ± 20 mV																		
Output ripple	< 10 mV _{RMS} at 30 KHz																		
Short circuit protection	Current limited outputs																		
Analog Input section (4 ch)																			
Input channels	4																		
Resolution	12 bits, or 4096 steps over the full input range																		
Input sensitivity (software selectable)																			
Voltage ranges	<table border="0"> <thead> <tr> <th>Unipolar</th> <th>Bipolar</th> </tr> </thead> <tbody> <tr> <td>0 to 10 V</td> <td>$\pm 10V$</td> </tr> <tr> <td>0 to 5 V</td> <td>$\pm 5V$</td> </tr> <tr> <td>0 to 2.5 V</td> <td>$\pm 2.5V$</td> </tr> <tr> <td>0 to 1.25 V</td> <td>$\pm 1.25V$</td> </tr> <tr> <td>0 to 1 V</td> <td>$\pm 1V$</td> </tr> <tr> <td>0 to .5 V</td> <td>$\pm .5V$</td> </tr> <tr> <td>0 to .25 V</td> <td>$\pm .25V$</td> </tr> <tr> <td>0 to .125 V</td> <td>$\pm .125V$</td> </tr> </tbody> </table>	Unipolar	Bipolar	0 to 10 V	$\pm 10V$	0 to 5 V	$\pm 5V$	0 to 2.5 V	$\pm 2.5V$	0 to 1.25 V	$\pm 1.25V$	0 to 1 V	$\pm 1V$	0 to .5 V	$\pm .5V$	0 to .25 V	$\pm .25V$	0 to .125 V	$\pm .125V$
Unipolar	Bipolar																		
0 to 10 V	$\pm 10V$																		
0 to 5 V	$\pm 5V$																		
0 to 2.5 V	$\pm 2.5V$																		
0 to 1.25 V	$\pm 1.25V$																		
0 to 1 V	$\pm 1V$																		
0 to .5 V	$\pm .5V$																		
0 to .25 V	$\pm .25V$																		
0 to .125 V	$\pm .125V$																		
Current range	0 to 20 mA, 4 to 20 mA																		
Common mode maximum voltage (The maximum voltage that can safely be applied between either input terminal and circuit common.)	$\pm 40V$																		
Common mode operating voltage (The maximum voltage that can be applied between either input terminal and circuit common with inputs still operating properly.)	$\pm 11V$																		

Analog Input $\pm 10V$ Output (4 Channel)

Internal current sense resistor	250 ohms
Maximum current sense resistor power	.12 W
Differential input resistance (each input to ground)	1 M Ohms
Filter time constant - software selection	1 ms, 10 ms, 100 ms
Accuracy	.5% of FSR at 25°C ± 100 PPM /°C
0 Offset	From ± 2 counts @ 10 V to ± 8 counts @ .125 V

TEMP J-K Thermocouple Module (12 channel)

The input temp J-K thermocouple modules (one for use with grounded thermocouples and one for use with ungrounded thermocouples) has 12 independent thermocouple or analog conversion channels which receive signals from J or K type thermocouples or from a voltage source. Each channel converts an analog signal into a 12-bit digital word which is processed by the PiC.

This module requires no hardware adjustments. All adjustments such as Fahrenheit or Celsius scaling and thermocouple ranges are software selectable.

The DIAG LED turns on briefly while the diagnostic tests are running.

INPUT TEMP J-K Module (12 CH)

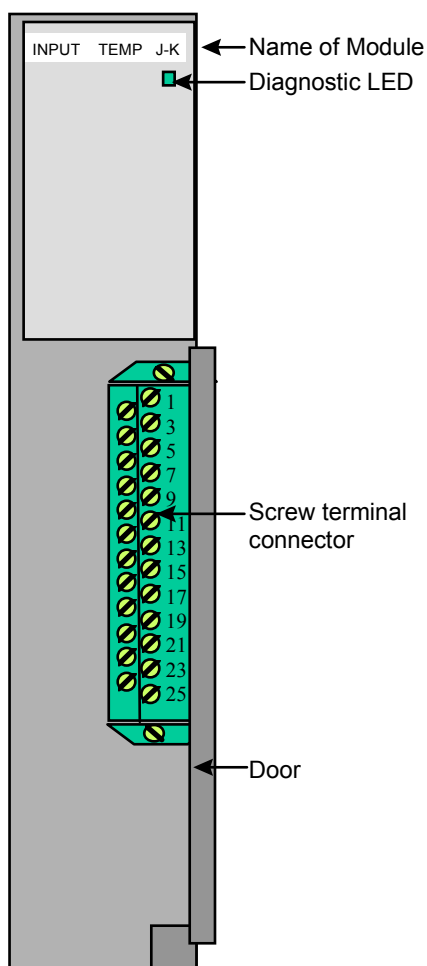

Specification Table

Characteristic	Thermocouple module specification
Function	Measure J or K type thermocouple wire inputs or ± 100 mV analog inputs
Part Number	Ungrounded M.1016.9108 (old # 502-03658-02) Grounded M.1016.9289 (old # 502-03809-02)
Field side connector	25-pin card edge connector, screw terminals
Input channels	12
Resolution	12 bits
Input voltage sensitivity (software selectable)	± 100 mV
J type thermocouple temperature ranges (at 25°C)	-150°C to 1200°C (-238°F to 2192° F) -35°C to 620°C (-31°F to 1148° F) -10°C to 280°C (+14°F to 536° F)
K type thermocouple temperature ranges (at 25°C)	-200°C to 1300°C (-328°F to 2372° F) -80°C to 820°C (-112°F to 1508° F) -35°C to 415°C (-31°F to 779° F)
J or K type accuracy	J type .37% of the 1350°C span K type .36% of the 1500°C span
± 100 mV accuracy	$\pm (50 \mu\text{V} + 1 \text{ count} + \text{input} \times 1\%)$
Time between samples (software selectable)	5000 to 65,535 μsec
Filter time constant	120 ms
Cold junction compensation	0 to 80°C $\pm 1^\circ\text{C}$ at the sensor
Open thermocouple detection	Indicated by software (No detection for grounded thermocouples)
Logic side power requirements (typical)	80 mA @ +5V 112 mA @ +15V
Indicator light, module	DIAG LED goes off after the module passes its diagnostic tests
Operating temperature range	7°C to 55°C (45°F to 131°F)
Storage temperature range	-40°C to 85°C (-40°F to 185°F)
Humidity	5 to 95%, non-condensing

EMC Compliant Emissions Noise immunity	Operates with emissions below EN55011/ CISPR 11 Class A limits Immune to: <ul style="list-style-type: none"> • Electrostatic discharge (4K V contact mode, 8K V air discharge) per IEC 1000-4-2 • RF electromagnetic fields per IEC 1000-4-3 • Electrical fast transients per IEC 1000-4-4 on incoming power lines Refer to the EMC Guidelines for more information.
UL and C/UL Listed	File No. E126417 NRAQ Programmable Controllers
Physical size	1.6" wide x 12" high x 8.4" deep (including latch) 41 mm x 305 mm x 213 mm
Vibration (per IEC 68-2-6)	10-57 Hz (constant amplitude .15 mm) 57-2000 Hz (acceleration 2 g)
Shock (per IEC 68-2-27)	Four shocks per axis (15g/11 msec)

NOTES

RTD Module (6 channel)

The input RTD (resistance temperature detector) module has 6 independent RTD conversion channels which receive signals from 50 $\frac{3}{4}$ or 100 $\frac{3}{4}$ RTDs. Each channel converts a resistance into a 12-bit digital word which is processed by the PiC.

This module requires no hardware adjustments. All adjustments such as Fahrenheit or Celsius scaling and temperature ranges are software selectable.

The DIAG LED turns on briefly while the diagnostic tests are running.

INPUT RTD Module (6 ch)

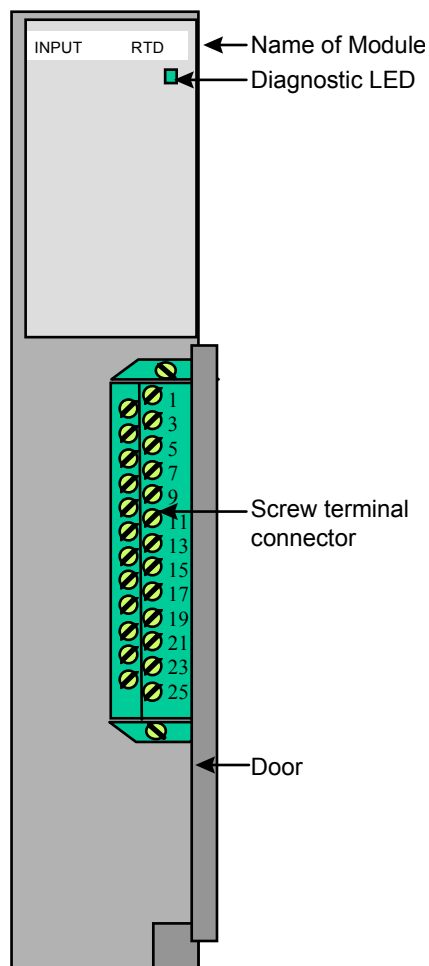

Specification Table

Characteristic	RTD module specification
Function	Measures 50 $\frac{3}{4}$ and 100 $\frac{3}{4}$ RTD inputs
Part Number	(M.1016.9154) (old # 502-03679-02)
Field side connector	25-pin card edge connector, screw terminals
Input channels	6
Resolution	12 bits
RTD types	European curve (Alpha = .00385) for 50 $\frac{3}{4}$ and 100 $\frac{3}{4}$ two and three wire RTDs
50 $\frac{3}{4}$ temperature ranges	-200°C to 850°C (-328°F to 1562° F) -200°C to 266°C (-328°F to 510.8° F)
100 $\frac{3}{4}$ temperature ranges	-200°C to 850°C (-328°F to 1562° F) -200°C to 266°C (-328°F to 510.8° F) -200°C to 0°C (-328°F to 32° F)
Maximum RTD lead wire length	
24 AWG or smaller	< 20 feet
20 AWG or larger	2-wire RTD - under 20 feet without lead compensation NOTE: Lead length can affect accuracy of 2-wire RTDs with lengths over 20 feet. 2-wire RTD - up to 5000 feet with lead compensation 3-wire RTD - up to 1000 feet without lead compensation 3-wire RTD - up to 5000 feet with lead compensation
Accuracy	.6% FSR @ 25°C Temperature coefficient of 75 PPM/°C
Time between samples (software selectable)	2000 to 65,535 μ sec
Filter time constant	120 ms
Open RTD detection	Indicated by software
Logic side power requirements (typical)	80 mA @ +5 V 112 mA @ +15 V
Indicator light, module	DIAG LED goes off after the module passes its diagnostic tests
Operating temperature range	7°C to 55°C (45°F to 131°F)

Storage temperature range	-40°C to 85°C (-40°F to 185°F)
Humidity	5 to 95%, non-condensing
EMC Compliant Emissions Noise immunity	Operates with emissions below EN55011/ CISPR 11 Class A limits Immune to: <ul style="list-style-type: none"> • Electrostatic discharge (4K V contact mode, 8K V air discharge) per IEC 1000-4-2 • RF electromagnetic fields per IEC 1000-4-3 • Electrical fast transients per IEC 1000-4-4 on incoming power lines Refer to the EMC Guidelines for more information.
UL and C/UL Listed	File No. E126417 NRAQ Programmable Controllers
Physical size	1.6" wide x 12" high x 8.4" deep (including latch) 41 mm x 305 mm x 213 mm
Vibration (per IEC 68-2-6)	10-57 Hz (constant amplitude .15 mm) 57-2000 Hz (acceleration 2 g)
Shock (per IEC 68-2-27)	Four shocks per axis (15g/11 msec)

NOTES

Output 4-20mA Module (6 channel)

The 4-20mA output module has six independent 4-20mA conversion channels. Each channel converts a 15-bit digital value into a single ended type 4-20mA analog current output signal. The full range of the output signal is 4mA to 20mA, with a 15-bit resolution of one part in 32,768.

A typical use for this module is to supply a control signal to valves. This module contains no user adjusted potentiometers or hardware switches. All necessary adjustments are done in software.

The DIAG LED goes on briefly while the diagnostic tests are running.

OUTPUT 4-20mA Module (6 CH)

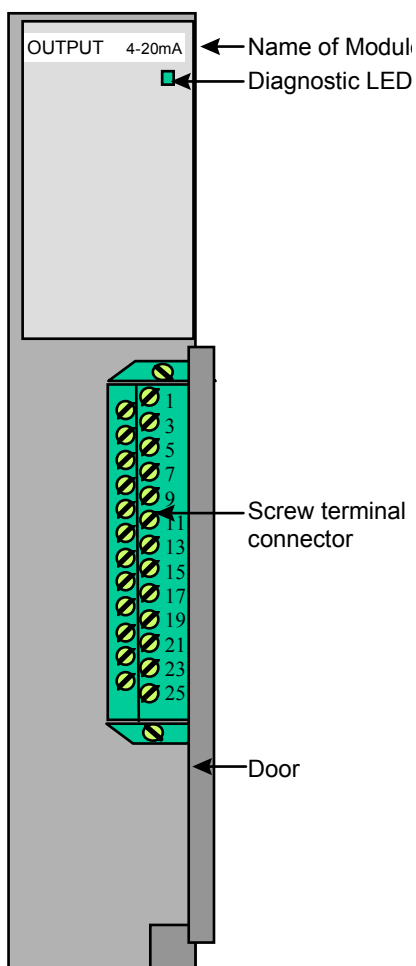

Specification Table

Characteristic	Output 4-20mA (6 ch) specification
Function	Converts a 15-bit digital value into a 4-20mA analog current signal for each of six channels
New Part number	M.1016.9160 (old # 502-03681-02)
Field side connector	25-pin card edge connector, screw terminals
Output channels	6
Resolution	15 bits, or 32,768 steps over the full output range
Zero Offset	.1% FSR (Full Scale Range) over full temperature range
Accuracy	.1% FSR (Full Scale Range) over full temperature range
Output current, max.	20 mA
Output update time increment	100 μ sec
Output voltage after power up	$V_{OUT} = I_{OUT} * R_{LOAD}$
Response to scan loss	All outputs reset to 4mA
Short circuit protection	Current is limited to: $I_{OUT} =$ where $I_{OUT} = 4$ to 20mA
Indicator light, module	DIAG LED goes off after module passes its diagnostic tests
External power supply +V and current Line and load regulation Maximum noise	+15 V to +24 V: \leq 250 mA .5% 100 mV pk-pk
Isolation	Field side has differential isolation via Op Amp buffer between logic and field side The open alarm flag is optically isolated between field and logic side
Logic side power requirements (typical)	125 mA @ +5 V 30 mA @+15 V 18 mA @-15 V
Operating temperature range	7°C to 55°C (45°F to 131°F)
Storage temperature range	-40°C to 85°C (-40°F to 185°F)
Humidity	5 to 95%, non-condensing

EMC Compliant Emissions Noise immunity	Operates with emissions below EN55011/ CISPR 11 Class A limits Immune to: <ul style="list-style-type: none"> • Electrostatic discharge (4K V contact mode, 8K V air discharge) per IEC 1000-4-2 • RF electromagnetic fields per IEC 1000-4-3 • Electrical fast transients per IEC 1000-4-4 on incoming power lines Refer to the EMC Guidelines for more information.
UL and C/UL Listed	File No. E126417 NRAQ Programmable Controllers
Physical size	1.6" wide x 12" high x 8.4" deep (including latch) 41 mm x 305 mm x 213 mm
Vibration (per IEC 68-2-6)	10-57 Hz (constant amplitude .15 mm) 57-2000 Hz (acceleration 2 g)
Shock (per IEC 68-2-27)	Four shocks per axis (15g/11 msec)

NOTES

MOTION SOLUTIONS PRODUCT GUIDE

PiC Family Miscellaneous Modules

Giddings & Lewis

Barrier Module

A Barrier module is available for any empty slot in the system rack. The part number for the barrier module is M.1016.9125 (new) and 502-03673-00 (old).

The Barrier Module

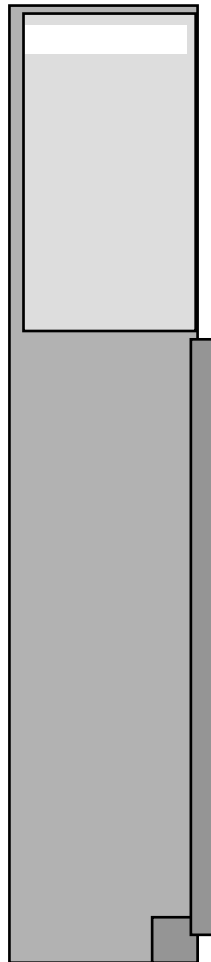

UL and C/UL Listed File No. E126417 NRAQ Programmable Controllers

**PiC900 CONTROLS
MOTION SOLUTIONS PRODUCT GUIDE**

**PiC 900 Servo/
Feedback Modules**

Giddings & Lewis

Encoder Module (2, 4, High Speed 4 channel)

The encoder module can interface to four or two independent incremental encoders or equivalent devices. Information from the encoders is used to update four or two separate position counters and latches within the module.

For each channel, a 24-bit counter is incremented or decremented based on signals it receives from the A and B outputs of an encoder. The counter value can be latched (stored) if the module receives either an “index” signal from the encoder or a 24V DC “fast” input signal.

An LED in the upper section of the module goes on when the fast input for each channel is energized. The DIAG LED goes on briefly while the diagnostics tests are running.

INPUT ENCODER Module (4 CH)

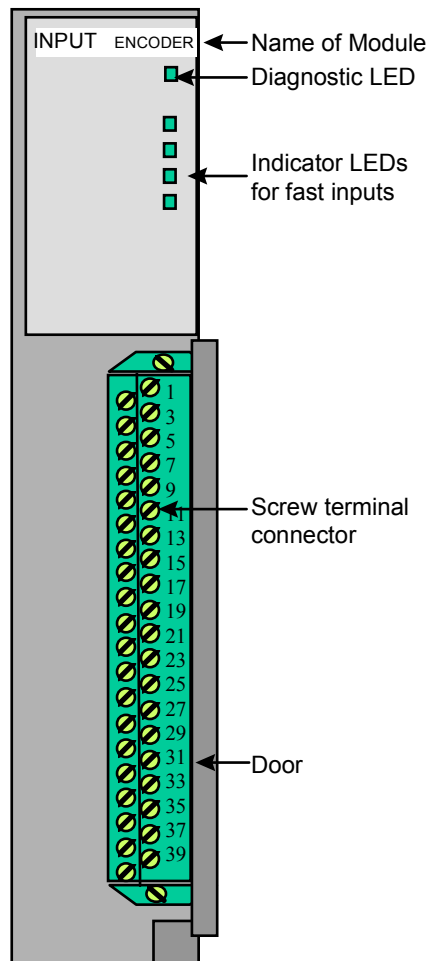

Specification table

Characteristic	Input Encoder module (2, 4, HS) specifications									
Function	Counts pulses from up to 4 encoders Latches the counter value at an index or 24 VDC input event									
Part number	<table border="1"> <tbody> <tr> <td>4 ch</td> <td>2.5 VDC - 7 VDC M.1016.9260 (old # 502-03782-02)</td> <td>3.5 VDC - 16.5 VDC M.1016.9264 (old # 502-03786-02)</td> </tr> <tr> <td>2 ch</td> <td>2.5 VDC - 7 VDC M.1016.9261 (old # 502-03782-22)</td> <td>N/A</td> </tr> <tr> <td>high speed</td> <td>M.1016.9433 (old # 502-03947-00)</td> <td>N/A</td> </tr> </tbody> </table>	4 ch	2.5 VDC - 7 VDC M.1016.9260 (old # 502-03782-02)	3.5 VDC - 16.5 VDC M.1016.9264 (old # 502-03786-02)	2 ch	2.5 VDC - 7 VDC M.1016.9261 (old # 502-03782-22)	N/A	high speed	M.1016.9433 (old # 502-03947-00)	N/A
4 ch	2.5 VDC - 7 VDC M.1016.9260 (old # 502-03782-02)	3.5 VDC - 16.5 VDC M.1016.9264 (old # 502-03786-02)								
2 ch	2.5 VDC - 7 VDC M.1016.9261 (old # 502-03782-22)	N/A								
high speed	M.1016.9433 (old # 502-03947-00)	N/A								
2,4 Ch Encoder (A, B, and index) High-speed Encoder	Differential or single ended; differential recommended 2632 differential receiver									
Guaranteed on, min.(2, 4 ch)	2.5V DC @ 2.5 mA 3.5V DC @ 7.3 mA									
Input voltage, max. (2, 4 ch) (high speed)	7V DC 16.5V DC 5V DC									
Input current, max. (2, 4 ch)	22 mA @ 7V DC 30 mA @ 16.5V DC									
Input voltage, threshold (high-speed) Input termination (high-speed)	±200 mV 120 ³ / ₄									
Signal pulse width, min. (2, 4 ch) (high-speed)	.6 μs(600 ns) 75 ns									
Quad signal freq, max. (2, 4 ch) (high-speed)	250 KHz for A or B input (1 M FU count rate) 2.5 MHz (10M FU count rate)									
Pulse signal freq, max. (2, 4 ch) (high-speed)	500 KHz for A or B input (500 KFU count rate) 5 MHz (5M FU count rate)									
Field side connection	40 pin card edge connector, screw terminals									
Encoder device	1. Quadrature type incremental encoder (recommended) 2. Pulse type incremental encoder									

Stored position value range	24-bit up/down counter 24-bit latch
Fast input	Nominal 24V DC, switched externally to the module Active high or low Reverse polarity protected
Voltage max.	30V DC
Guaranteed on	15V DC
Guaranteed off	5V DC
Input impedance	2.7 K
On/off time, max.	50 μ s
Indicator light	LED is lit when current flows into the input
Indicator light, module	DIAG LED goes off after the module passes its diagnostic tests
Cable length, max. (2, 4 ch)	200 ft. @ 250 KHz and 45° quad error (with differential driver)
Cable length, max. (high speed)	50 ft. @ 2.5 MHz with 100 ns minimum separation between A and B
Logic side power requirements (typical for 2, 4 ch)	572 mA @ +5V 1 mA @ +15V 1 mA @ -15V 21 mA per energized input @ +5V 12 mA per fast input @ +5V
Logic side power requirements (typical for high-speed)	370 mA @ +5V 12 mA per fast input @ +5V
Field side power dissipation, worst case (2, 4 ch)	7.4 W
Field side power dissipation, worst case (high speed)	1.5 W from encoder +5 V supply 1.6 W from fast input supply
Operating temperature range	7°C to 55°C (45°F to 131°F)
Storage temperature range	-40°C to 85°C (-40°F to 185°F)
Humidity	5 to 95%, non-condensing

Encoder Module (2, 4, High Speed 4 channel)

<p>EMC Compliant Emissions</p> <p>Noise immunity</p>	<p>Operates with emissions below EN55011/ CISPR 11 Class A limits</p> <p>Immune to:</p> <ul style="list-style-type: none"> • Electrostatic discharge (4K V contact mode, 8K V air discharge) per IEC 1000-4-2 • RF electromagnetic fields per IEC 1000-4-3 • Electrical fast transients per IEC 1000-4-4 on incoming power lines <p>Refer to the EMC Guidelines for more information.</p>
<p>UL and C/UL Listed</p>	<p>File No. E126417 NRAQ Programmable Controllers</p>
<p>Physical size</p>	<p>1.6" wide x 12" high x 8.4" deep (including latch) 41 mm x 305 mm x 213 mm</p>
<p>Vibration (per IEC 68-2-6)</p>	<p>10-57 Hz (constant amplitude .15 mm) 57-2000 Hz (acceleration 2 g)</p>
<p>Shock (per IEC 68-2-27)</p>	<p>Four shocks per axis (15g/11 msec)</p>

Resolver Module (4, 2 channel)

The resolver module can interface to four or two independent resolvers (or equivalent transducers). Information from the resolvers is used to update four or two separate position counters and latches within the module.

For each channel, the module sends out two sine waves 90° out of phase with each other and receives a signal whose phase represents the angular position of the resolver. This input signal is used to update a 24-bit counter. This module can be programmed to "latch" (store) the counter value when a signal is received by the fast input for that channel.

An LED in the upper section of the module goes on when the fast input for each channel is energized. The DIAG LED goes on briefly while the diagnostics tests are running.

INPUT RESOLVER Module (4 CH)

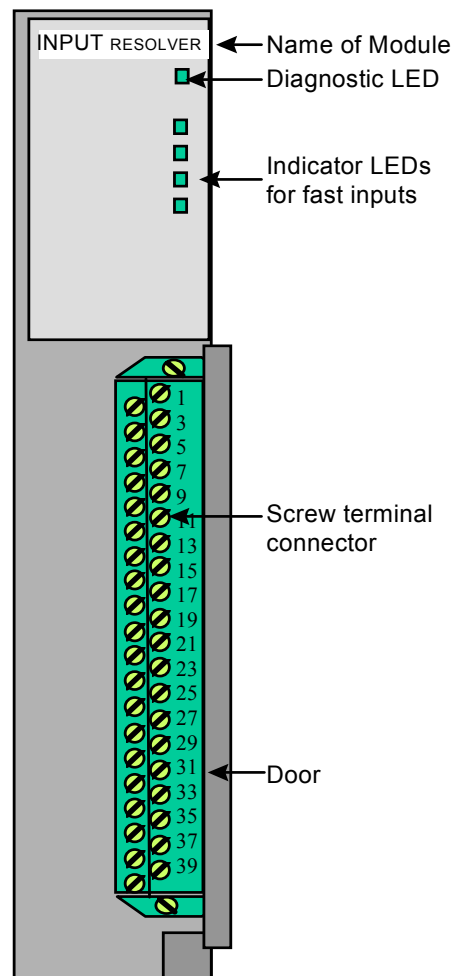

Specification Table

Characteristic	Input Resolver module specifications
Function	Measures the position of a transducer that accepts a 2-phase quadrature excitation, such as a resolver or potentiometer
Part number	4 ch M.1016.8949 (old # 502-03552-02) 2 ch M.1016.8951 (old # 502-03552-22)
Field side connector	40 pin card edge connector, screw terminals
Excitation method	2-phase quadrature for control transformer type of resolver
Excitation frequency	2 KHz
RPO and QPO outputs	
Output voltage	16V P-P (5.7V RMS)
Current per output channel, max.	4ch 5mA RMS (14 mA P-P) 2 ch 10mA RMS (20 mA P-P)
Resolver transformer ratio	.5 to 1.0
Resolution, resolver	4000 Feedback Units (FUs) per electrical revolution
Resolution, potentiometer	1000 Feedback Units (FUs) per electrical revolution
Accuracy at constant temperature	± 20 arc minutes
Accuracy over temperature range	± 45 arc minutes
Electrical velocity, max.	15000 RPM (1M FU/Sec.)
Cable length, max.	200 ft.
Stored position value range	24-bit up/down counter 24-bit latch
Fast input	Nominal 24V DC
Reverse polarity protection	YES
Voltage max.	30V DC
Guaranteed on	15V DC
Guaranteed off	5V DC
Input impedance	2.7 K
On/off time, max.	50 μs
Indicator lights, fast inputs	LED is lit when current flows into the input.

Indicator light, module	DIAG LED goes off when the module passes its diagnostic tests
Logic side power requirements (typical for 4 ch)	<p>473 mA @ 5V 133 mA @ +15V 20 mA @ -15V</p> <p>14 mA per energized input @ +15V 14 mA per energized input @ -15V 12 mA per fast input</p>
Logic side power requirements (typical for 2 ch)	<p>296 mA @ 5V 105 mA @ +15V 16 mA @ -15V</p> <p>14 mA per energized input @ +15V 14 mA per energized input @ -15V 13 mA per fast input</p>
Field side power dissipation, worst case	4 ch 1.4 W 2 ch .7 W
Recommended resolver	Part number M.1200.0399 (old # 501-98409-00) Harowe 11BRW 300-F-1/10
Other suggested resolvers	Clifton 11BHW-0IE/A004 Kearfott CR41095050
Operating temperature range	7°C to 55°C (45°F to 131°F)
Storage temperature range	-40°C to 85°C (-40°F to 185°F)
Humidity	5 to 95%, non-condensing
EMC Compliant Emissions Noise immunity	<p>Operates with emissions below EN55011/ CISPR 11 Class A limits</p> <p>Immune to:</p> <ul style="list-style-type: none"> • Electrostatic discharge e(4K V contact mode, 8K V air discharge) per IEC 1000-4-2 • RF electromagnetic fields per IEC 1000-4-3 • Electrical fast transients per IEC 1000-4-4 on incoming power lines <p>Refer to the EMC Guidelines for more information.</p>
UL and C/UL Listed	File No. E126417 NRAQ Programmable Controllers
Physical size	1.6" wide x 12" high x 8.4" deep (including latch) 41 mm x 305 mm x 213 mm
Vibration (per IEC 68-2-6)	10-57 Hz (constant amplitude .15 mm) 57-2000 Hz (acceleration 2 g)
Shock (per IEC 68-2-27)	Four shocks per axis (15g/11 msec)

NOTES

Multi-Channel Resolver Module (12 channel)

The input multi-channel resolver module can interface to 12 independent resolvers (or equivalent transducers). Feedback information from the resolvers is used to update the on-board memory. The position of each resolver can be read at any time by the PiC.

For each channel, the module sends out two sine waves 90° out of phase with each other and receives a signal whose phase represents the angular position of the resolver. The resolution of the angular position is 4000 counts per revolution or 0.09 degrees.

The DIAG LED goes on briefly while the diagnostic tests are running.

INPUT RESOLVER (Multi-Channel) Module (12 CH)

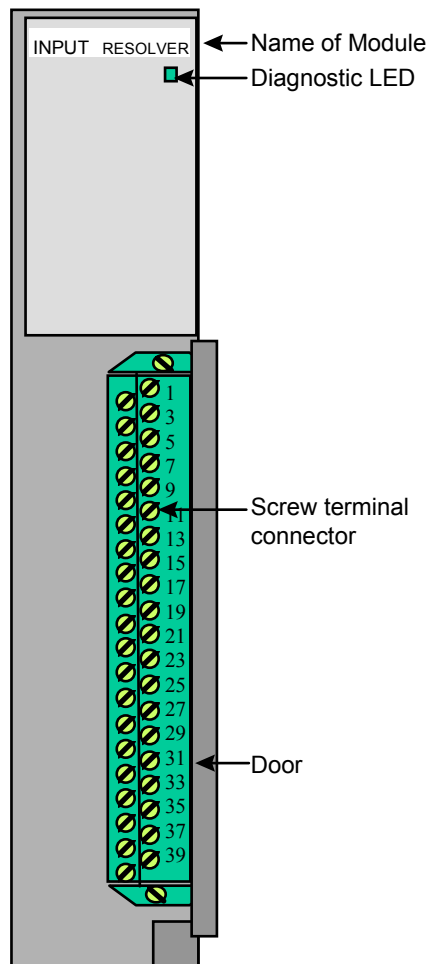

Specification Table

Characteristic	Input Resolver (12 ch) Module Specifications
Function	Measures the position of a transducer that accepts a 2-phase quadrature excitation, such as a resolver or potentiometer
Part number	M.1016.9231 (old # 502-03722-02)
Field side connector	40 pin card edge connector, screw terminals
Excitation method	2-phase quadrature for control transformer type of resolver
Excitation frequency	4KHz
RPO and QPO outputs	
Output voltage	15V P-P (5.3V RMS)
Current per output channel, max.	100 mA
Resolver transformer ratio	.5 to 1.0
Resolution, resolver	4000 Feedback Units (FUs) per electrical revolution
Resolution, potentiometer	1000 Feedback Units (FUs) per electrical revolution
Accuracy at constant temperature	± 12 arc minutes
Accuracy over temperature range	± 5.4 arc minutes /10°F
Velocity, max.	15000 electrical RPM (1M FU/Sec.)
Cable length, max.	6 ft. from module to terminal block (18 AWG) 100 ft. from terminal block to resolvers (twisted pair)
Stored position value range	0-3999
Indicator light, module	DIAG LED goes off when the module passes its power-on diagnostic tests
Logic side power requirements (typical)	200 mA @ +5V 60 mA @ +15V 60 mA @ -15V
Recommended resolver	Giddings & Lewis part number 501-98409-00 Harowe 11BRW 300-F-1/10
Other suggested resolvers	Clifton 11BHW-01E/A004 Kearfott CR410959
Operating temperature range	7° C to 55° C (45° F to 131° F)
Storage temperature range	-40° C to 85° C (-40° F to 185° F)
Humidity	5 to 95%, non-condensing

EMC Compliant Emissions Noise immunity	Operates with emissions below EN55011/ CISPR 11 Class A limits Immune to: <ul style="list-style-type: none"> • Electrostatic discharge (4K V contact mode, 8K V air discharge) per IEC 1000-4-2 • RF electromagnetic fields per IEC 1000-4-3 • Electrical fast transients per IEC 1000-4-4 on incoming power lines Refer to the EMC Guidelines for more information.
UL and C/UL Listed	File No. E126417 NRAQ Programmable Controllers
Physical size	1.6" wide x 12" high x 8.4" deep (including latch) 41 mm x 305 mm x 213 mm
Vibration (per IEC 68-2-6)	10-57 Hz (constant amplitude .15 mm) 57-2000 Hz (acceleration 2 g)
Shock (per IEC 68-2-27)	Four shocks per axis (15g/11 msec)

Servo Encoder with Analog I/O Module

The servo encoder with analog I/O module provides:

- Two analog output channels
- Four analog input channels
- Three encoder input channels
- Three fast inputs

An LED goes on when the fast input for each encoder channel is energized.

The DIAG LED goes on briefly while the diagnostic tests are running.

Servo Module Encoder with Analog Inputs

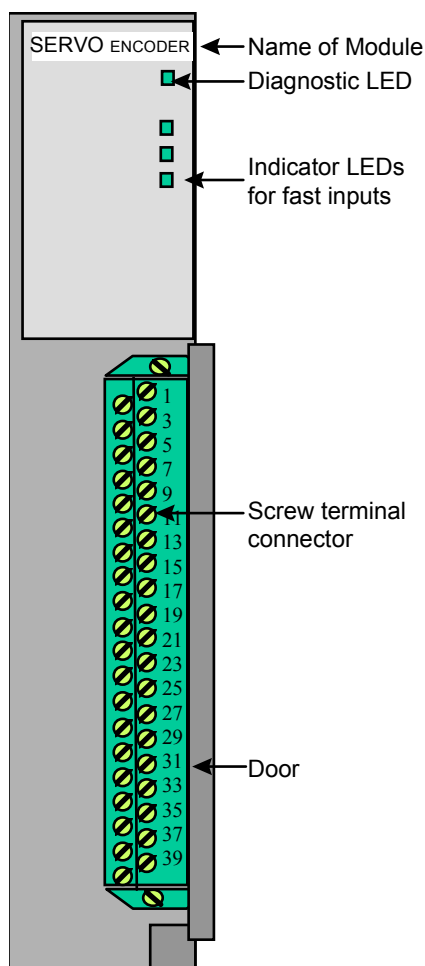

Specification Table

Characteristic	Servo Encoder module specifications
Function	<p>Converts a 16-bit digital word into a $\pm 11\text{V}$ analog output signal for each of two channels</p> <p>Converts an analog input signal into a 12-bit digital word for each of four channels.</p> <p>Counts pulses from up to three encoders</p> <p>Latches the counter value at an index or 24 VDC fast input event</p>
Part number	M.1016.9329 (old # 502-03839-04)
Logic side power requirements (typical)	<p>482 mA @ +5V 42 mA @ +15V 62 mA @ -15V</p> <p>Analog Output</p> <p>1 mA per energized output @ +5V 11 mA per energized output @ +15V 11 mA per energized output @ -15V</p> <p>Analog Input</p> <p>120 mA @ +5V 112 mA @ +15V</p> <p>Encoder</p> <p>21 mA per energized input @ +5V 12 mA per fast input @ +5V</p>
Field side connection	40 pin card edge connector, screw terminals
Field side power dissipation, worst case	7.4 W
Indicator light, module	DIAG LED goes off after the module passes its diagnostic tests
Indicator light	LED is lit when current flows into the fast input
Operating temperature range	7°C to 55°C (45°F to 131°F)
Storage temperature range	-40°C to 85°C (-40°F to 185°F)
Humidity	5 to 95%, non-condensing
EMC Compliant	<p>Emissions</p> <p>Operates with emissions below EN55011/ CISPR 11 Class A limits</p> <p>Noise immunity</p> <p>Immune to:</p> <ul style="list-style-type: none"> • Electrostatic discharge (4K V contact mode, 8K V air discharge) per IEC 1000-4-2 • RF electromagnetic fields per IEC 1000-4-3 • Electrical fast transients per IEC 1000-4-4 on incoming power lines <p>Refer to the EMC Guidelines for more information.</p>
UL and C/UL Listed	File No. E126417 NRAQ Programmable Controllers

Servo Encoder with Analog I/O Module

Physical size	1.6" wide x 12" high x 8.4" deep (including latch) 41 mm x 305 mm x 213 mm	
Vibration (per IEC 68-2-6)	10-57 Hz (constant amplitude .15 mm) 57-2000 Hz (acceleration 2 g)	
Shock (per IEC 68-2-27)	Four shocks per axis (15g/11 msec)	
Analog Output section (2 ch)		
Output channels	2	
Resolution	16 bits, or 65536 steps over the full output range	
Output voltage characteristics		
Nominal voltage range	± 11V DC	
Voltage accuracy @ 11 V	± 5%	
Output current, max. @ ±10V	± 10 mA	
Output update time increment	32 µsec	
Output voltage after power up	0V ± 20 mV	
Response to scan loss	All outputs reset to 0V ± 20 mV	
Output ripple	< 10 mV _{RMS} at 30 KHz	
Short circuit protection	Current limited outputs	
Analog Input section (4 ch)		
Input channels	4	
Resolution	12 bits, or 4096 steps over the full input range	
Input sensitivity (software selectable)		
Voltage ranges	Unipolar	Bipolar
	0 to 10V	±10V
	0 to 5V	±5V
	0 to 2.5V	±2.5V
	0 to 1.25V	±1.25V
	0 to 1V	±1V
	0 to .5V	±.5V
	0 to .25V	±.25V
Current range	0 to 20 mA, 4 to 20 mA	
Common mode maximum voltage (The maximum voltage that can safely be applied between either input terminal and circuit common.)	±40V	
Common mode operating voltage (The maximum voltage that can be applied between either input terminal and circuit common with inputs still operating properly.)	±11V	
Internal current sense resistor	250 ohms	
Maximum current sense resistor power	.12 W	

Differential input resistance (each input to ground)	1 M Ohms
Filter time constant - software selection	1 ms, 10 ms, 100 ms
Accuracy	.5% of FSR at 25°C ± 100 PPM /°C
0 Offset	From ±2 counts @ 10 V to ±8 counts @ .125 V
Encoder Input section (3 ch)	
Input Encoder (3 ch) (A, B, and index)	Differential or single ended; differential recommended
Guaranteed on, min.	2.5V DC @ 2.5 mA
Input voltage, max.	7V DC
Input current, max.	22 mA @ 7V DC
Signal pulse width, min.	.6 µs(600 ns)
Quadrature signal frequency, max.	250 KHz for A or B input (1 M FU count rate)
Pulse encoder signal frequency, max.	500 KHz for A or B input (500 KFU count rate)
Encoder device	1. Quadrature type incremental encoder (recommended) 2. Pulse type incremental encoder
Stored position value range	24-bit up/down counter 24-bit latch
Fast input	Nominal 24V DC, switched externally to the module Active high or low Reverse polarity protected
Voltage max.	30V DC
Guaranteed on	15V DC
Guaranteed off	5V DC
Input impedance	2.7 K
On/off time, max.	50 µs
Cable length, max.	200 ft. @ 250 KHz and 45° quad error (with differential driver)

Servo Encoder with Analog Output Module

Depending on the model you have, the Servo encoder with analog output module provides:

- Four, three, or two analog output channels
- Three, two or one encoder input channels
- Three, two, or one fast inputs

An LED goes on when the fast input for each encoder channel is energized.

The DIAG LED goes on briefly while the diagnostic tests are running.

Servo Module (Encoder)

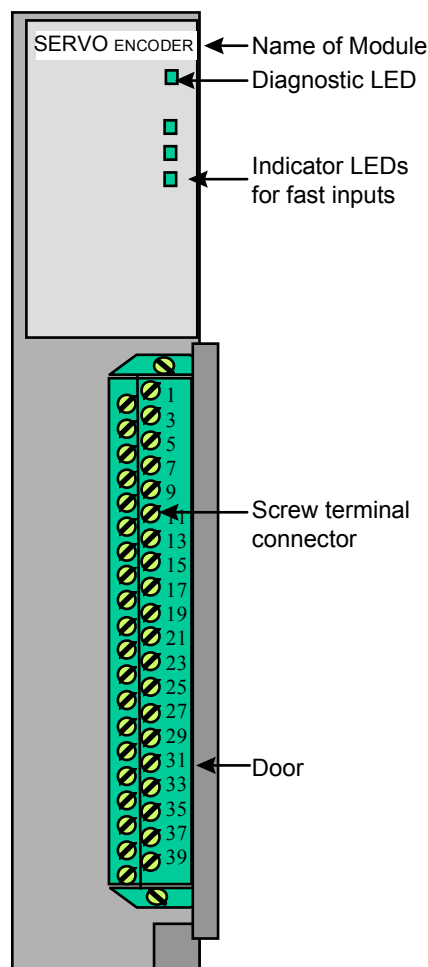

Specification Table

Characteristic	Servo module encoder specifications
Function	Converts a 16-bit digital word into a $\pm 11\text{V}$ analog output signal for each of two channels Counts pulses from up to three encoders Latches the counter value at an index or 24 VDC input event
Part number	4 Analog Outputs/3 Encoder Inputs M.1016.9333 (old # 502-03840-24) 3 Analog Outputs/2 Encoder Input M.1016.9338 (old # 502-03840-44) 2 Analog Outputs/1 Encoder Input M.1016.9343 (old # 502-03840-24)
Logic side power requirements (typical)	413 mA @ +5V 55 mA @ +15V 51 mA @ -15V Analog Output 1 mA per energized output @ +5V 11 mA per energized output @ +15V 11 mA per energized output @ -15V Encoder 21 mA per energized input @ +5V 12 mA per fast input @ +5V
Field side connection	40 pin card edge connector, screw terminals
Field side power dissipation, worst case	7.4 W
Indicator light, module	DIAG LED goes off after the module passes its diagnostic tests
Indicator light, fast inputs	LED is lit when current flows into the fast input
Operating temperature range	7°C to 55°C (45°F to 131°F)
Storage temperature range	-40°C to 85°C (-40°F to 185°F)
Humidity	5 to 95%, non-condensing

EMC Compliant	
Emissions	Operates with emissions below EN55011/ CISPR 11 Class A limits
Noise immunity	Immune to: <ul style="list-style-type: none"> • Electrostatic discharge (4K V contact mode, 8K V air discharge) per IEC 1000-4-2 • RF electromagnetic fields per IEC 1000-4-3 • Electrical fast transients per IEC 1000-4-4 on incoming power lines Refer to the EMC Guidelines for more information.
UL and C/UL Listed	File No. E126417 NRAQ Programmable Controllers
Physical size	1.6" wide x 12" high x 8.4" deep (including latch) 41 mm x 305 mm x 213 mm
Vibration (per IEC 68-2-6)	10-57 Hz (constant amplitude .15 mm) 57-2000 Hz (acceleration 2 g)
Shock (per IEC 68-2-27)	Four shocks per axis (15g/11 msec)
Analog Output section (4, 3, or 2 ch)	
Resolution	16 bits, or 65536 steps over the full output range
Output voltage characteristics	
Nominal voltage range	± 11V DC
Voltage accuracy @ 11 V	± 5%
Output current, max. @ ±10V	± 10 mA
Output update time increment	32 μsec
Output voltage after power up	0V ± 20 mV
Response to scan loss	All outputs reset to 0V ± 20 mV
Output ripple	< 10 mV _{RMS} at 30 KHz
Short circuit protection	Current limited outputs
Response to scan loss	All outputs are reset to the OFF state
Encoder Input section (3, 2, or 1 ch)	
Input Encoder (A, B, and index)	Differential or single ended; differential recommended
Guaranteed on, min	2.5V DC @ 2.5 mA
Input voltage, max	7V DC

Input current, max	22 mA @ 7V DC
Signal pulse width, min	.6 μ s (600 ns)
Quadrature signal frequency, max	250 KHz for A or B input (1 M FU count rate)
Pulse encoder signal frequency, max	500 KHz for A or B input (500 K FU count rate)
Encoder device	1. Quadrature type incremental encoder (recommended) 2. Pulse type incremental encoder
Stored position value range	24-bit up/down counter 24-bit latch
Fast input	Nominal 24V DC, switched externally to the module Active high or low Reverse polarity protected
Voltage max	30V DC
Guaranteed on	15V DC
Guaranteed off	5V DC
Input impedance	2.7 K
On/off time, max	50 μ s
Cable length, max	200 ft. @ 250 KHz and 45° quad error (with differential driver)

Slider Driver Module

The Slider Driver module is an interface between the PiC Resolver module and up to two independent Inductosyn systems.

For each Inductosyn system, the Slider Driver module accepts two sinusoidal signals from the Resolver module and applies them to the slider of the Inductosyn system. The Slider Driver module then accepts feedback from the scale amplifier of the Inductosyn system, conditions the signal, and passes this information to the Resolver module. The Resolver module uses the feedback signal to determine position information.

Refer to the Input Resolver Module for additional information.

Slider Driver Module

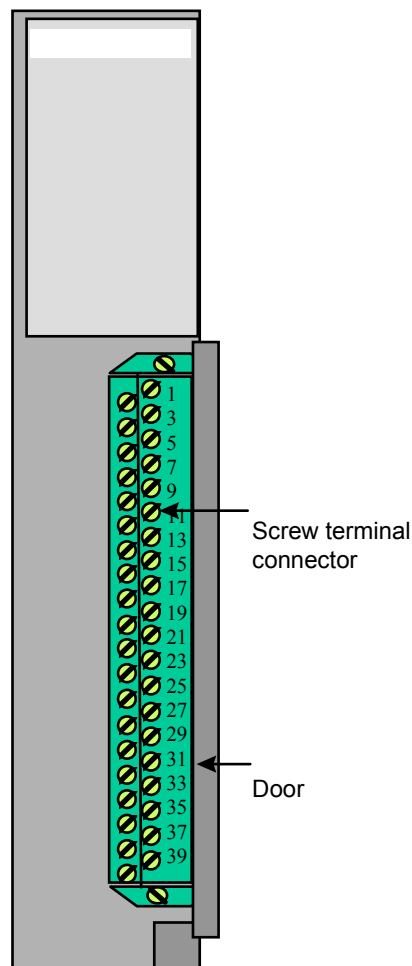

Specification Table

Characteristic	Slider Driver Module Specifications
Function	Drives up to two Inductosyn sliders
Part number	M.1016.9443 (old # 502-03956-02)
Field side connector	40 pin card edge connector, screw terminals
External Supply	
Input Voltage range	+18 to 30V DC
Nominal input	+24V DC
Input current (max)	1Amp
Output Voltages	±12V DC current limited
Scale Amplifier	Part Number M.1200.2894 (old # 503-13704-00) NOTE: If the Inductosyn scales and sliders are purchased from Giddings & Lewis, this is the required scale amplifier.
Operating temperature range	7° C to 55° C (45° F to 131° F)
Storage temperature range	-40° C to 85° C (-40° F to 185° F)
Humidity	5 to 95%, non-condensing
EMC Compliant	
Emissions	Operates with emissions below EN55011/ CISPR 11 Class A limits
Noise immunity	Immune to: <ul style="list-style-type: none"> • Electrostatic discharge (4K V contact mode, 8K V air discharge) per IEC 1000-4-2 • RF electromagnetic fields per IEC 1000-4-3 • Electrical fast transients per IEC 1000-4-4 on incoming power lines Refer to the EMC Guidelines for more information.
UL and C/UL Listed	File No. E126417 NRAQ Programmable Controllers
Physical size	1.6" wide x 12" high x 8.4" deep (including latch) 41 mm x 305 mm x 213 mm
Vibration (per IEC 68-2-6)	10-57 Hz (constant amplitude .15 mm) 57-2000 Hz (acceleration 2 g)
Shock (per IEC 68-2-27)	Four shocks per axis (15g/11 msec)

Output Stepper Module (8 channel)

The output stepper motor control module (SMCM) can control up to eight stepper drives. The maximum step rate is one million steps per second.

An external power supply is required for operation.

Commands and control data are sent to the module and status and position information are received from the module via software.

The DIAG LED goes on briefly while the diagnostic tests are running.

OUTPUT STEPPER Module (8 ch)

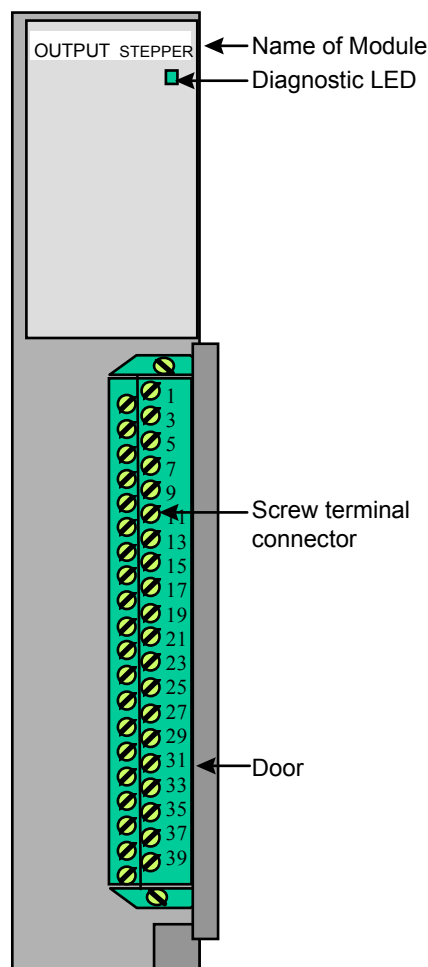

Specification Table

Characteristic	Output stepper module (8 ch) specifications
Function	Controls up to eight stepper drives
Part Number	M.1016.9146 (old # 502-03677-02 8 channel)
+V input (from external supply)	4.5V DC to 20V DC, 45 mA per connected channel
Step/CW output rating Direction/CCW output rating	Totem pole, 15 mA sink, 5 mA source
Field side connector	40-pin card edge connector, screw terminals
Protection of logic circuits	Optical isolation between the logic and field side
Indicator light, module	A DIAG LED turns OFF when the module passes its diagnostic tests at power-on
Position range	±2,147,352,575 steps
Step rate	0 to 1,000,000 steps/sec
Step rate accuracy	$ActualRate = \frac{10 \times 10^6}{X}$ <p>where X is the integer quotient of $\frac{10 \times 10^6}{ProgrammedRate}$</p>
Acceleration/deceleration rate	1 to 16,777,215 steps/sec/sec
Reference range	±2,147,352,575 steps
Response to scan loss	Pulse output halted
Logic side power requirements (typical)	404 mA @ +5V 8 channel 6 mA per active channel @ +5V
Operating temperature range	7° C to 55° C (45° F to 131° F)
Storage temperature range	-40° C to 85° C (-40° F to 185° F)
Humidity	5 to 95%, non-condensing
EMC Compliant Emissions Noise immunity	<p>Refer to the EMC Guidelines for more information.</p> <p>Operates with emissions below EN55011/ CISPR 11 Class A limits</p> <p>Immune to:</p> <ul style="list-style-type: none"> • Electrostatic discharge (4K V contact mode, 8K V air discharge) per IEC 1000-4-2 • RF electromagnetic fields per IEC 1000-4-3 • Electrical fast transients per IEC 1000-4-4 on incoming power lines

Output Stepper Module (8 channel)

UL and C/UL Listed	File No. E126417 NRAQ Programmable Controllers
Physical size	1.6" wide x 12" high x 8.4" deep (including latch) 41 mm x 305 mm x 213 mm
Vibration (per IEC 68-2-6)	10-57 Hz (constant amplitude .15 mm) 57-2000 Hz (acceleration 2 g)
Shock (per IEC 68-2-27)	Four shocks per axis (15g/11 msec)

Output Stepper Axis Module (8 channel)

The output stepper axis module (SAM) can control up to eight stepper drives. The maximum step rate is ten million steps per second.

An external power supply (4.75V DC to 5.25V DC) is required for operation.

Commands and control data are sent to the module and status information is received from the module via the motion.lib software in PiCServoPro.

The DIAG LED goes on briefly while the diagnostic tests are running.

OUTPUT STEPPER Axis Module (8 ch)

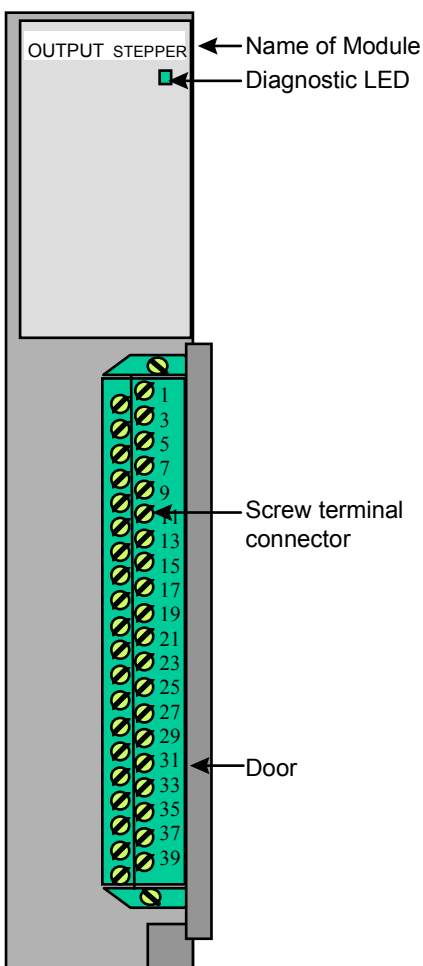

Specification Table

Characteristic	Output stepper module (8 ch) specifications
Function	Controls up to eight stepper drives
Part number	M.1016.9582 (old # 502-04077-00 8 channel)
+V input (from external supply)	4.75V DC to 5.25V DC, 45 mA per connected channel
Step/CW output rating Direction/CCW output rating	Totem pole, 15 mA sink, 5 mA source
Field side connector	40-pin card edge connector, screw terminals
Protection of logic circuits	Optical isolation between the logic and field side
Indicator light, module	A DIAG LED turns OFF when the module passes its diagnostic tests at power-on
Step rate	0 to 10,000,000 steps/sec
Step rate accuracy	$ValidRate = \frac{10 \times 10^6}{X}$ where X is any integer from 1 to 8,388,609
Response to scan loss	Pulse output halted
Logic side power requirements (typical)	120 mA @ +5V 8 channel
Operating temperature range	7° C to 55° C (45° F to 131° F)
Storage temperature range	-40° C to 85° C (-40° F to 185° F)
Humidity	5 to 95%, non-condensing

<p>EMC Compliant</p> <p>Emissions</p> <p>Noise immunity</p>	<p>Operates with emissions below EN55011/ CISPR 11 Class A limits</p> <p>Immune to:</p> <ul style="list-style-type: none"> • Electrostatic discharge (4K V contact mode, 8K V air discharge) per IEC 1000-4-2 • RF electromagnetic fields per IEC 1000-4-3 • Electrical fast transients per IEC 1000-4-4 on incoming power lines <p>Refer to the EMC Guidelines for more information.</p>
<p>UL and C/UL Listed</p>	<p>File No. E126417 NRAQ Programmable Controllers</p>
<p>Physical size</p>	<p>1.6" wide x 12" high x 8.4" deep (including latch) 41 mm x 305 mm x 213 mm</p>
<p>Vibration (per IEC 68-2-6)</p>	<p>10-57 Hz (constant amplitude .15 mm) 57-2000 Hz (acceleration 2 g)</p>
<p>Shock (per IEC 68-2-27)</p>	<p>Four shocks per axis (15g/11 msec)</p>

SERCOS Module for PiC

The SERCOS module is an interface between the PiC and up to two fiber optic rings of from one to eight SERCOS slaves. The module contains an on-board processor. Five LEDs provide diagnostic information and transmit and receive status for the SERCOS ports. There are two SERCOS ports located at the bottom of the module. Each port has a receive and a transmit fiber optic connector. There is also an RS232 port used for loading FLASH memory updates.

NOTE: The SERCOS module must be used with an EMC-compliant or CE-marked rack.

SERCOS Module

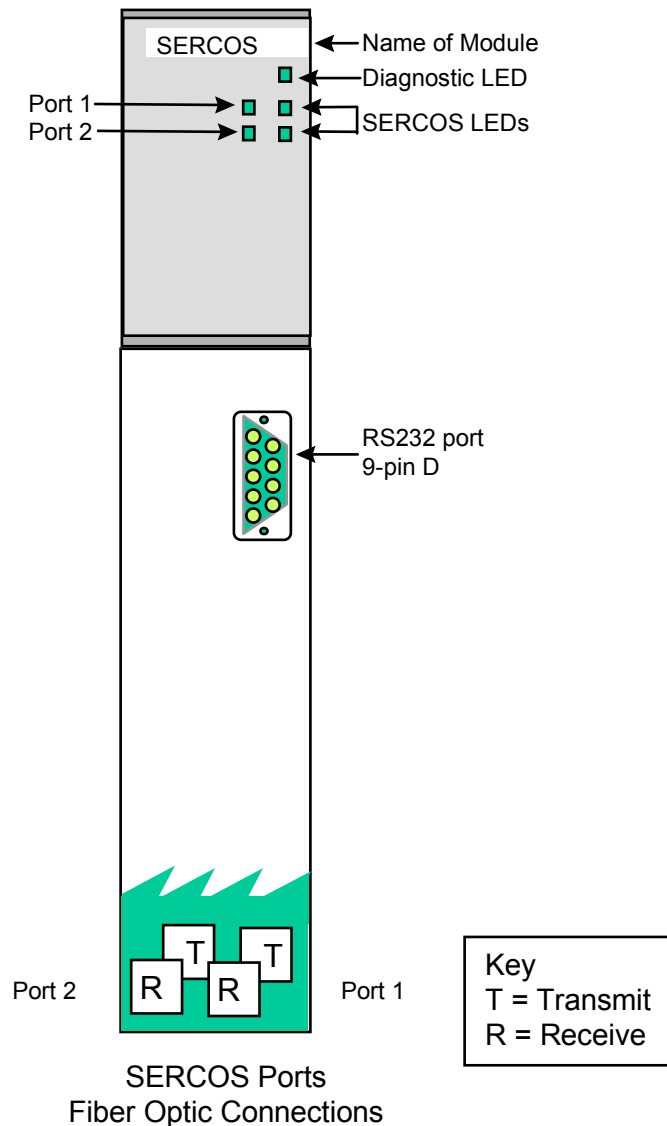

Specification Table

Characteristic	SERCOS Module Specifications
Function	Interfaces with up to two rings with from one to eight digital drives
Part number	One-Ring Module M.1016.9429 (old # 502-03944-10) Two-Ring Module M.1016.9428 (old # 502-03944-00)
SERCOS port	SMA female connectors for interfacing to 1000 μ meter plastic fiber optic cable with SMA male connectors
Update port	RS232 interface Fiber optic receiver specifications: Peak input power (optical level low) -31.2 dBm max Peak input power (optical level high) -20.0 dBm min -5.0 dBm max Fiber optic transmitter specifications: Peak output power (optical level high) -10.5 dBm min -5.5 dBm max
Logic side power require.	575 mA @ 5V
Operating temperature range	7° C to 55° C (45° F to 131° F)
Storage temperature range	-40° C to 85° C (-40° F to 185° F)
Humidity	5 to 95%, non-condensing
EMC Compliant Emissions Noise immunity	Operates with emissions below EN55011/ CISPR 11 Class A limits Immune to: <ul style="list-style-type: none"> • Electrostatic discharge (4K V contact mode, 8K V air discharge) per IEC 1000-4-2 • RF electromagnetic fields per IEC 1000-4-3 • Electrical fast transients per IEC 1000-4-4 on incoming power lines Refer to the EMC Guidelines for more information.
UL and C/UL Listed	File No. E126417 NRAQ Programmable Controllers
Physical size	1.6" wide x 12" high x 8.4" deep (including latch) 41 mm x 305 mm x 213 mm
Vibration (per IEC 68-2-6)	10-57 Hz (constant amplitude .15 mm) 57-2000 Hz (acceleration 2 g)
Shock (per IEC 68-2-27)	Four shocks per axis (15g/11 msec)

Specification Table for the Fiber Optic Cable

Characteristics	Fiber optic cable specifications
Function	For use with SERCOS rings with segments from 0 to 30 meters (98 feet)
Type	Plastic with step index profile
Core diameter Fiber diameter	980µm ±60µm 1000µm ±60µm
Operating temperature	0° C to 55° C (32° F to 131° F)
Minimum bend radius	One time: 30mm Continuous: 80mm
Tensile strength	One time: 250N Continuous: 100N
Connectors	SMA style which accommodates 1000µm size cable

**PiC900 CONTROLS
MOTION SOLUTIONS PRODUCT GUIDE**

PiC 900 Options and Accessories

Giddings & Lewis

PiC Options and Accessories

I/O Wiring Harness

There is an optional wiring harness available which can be used to replace the discrete wiring from some of the PiC input and output modules (see table below) to field side terminal blocks. It consists of a cable and a terminal strip interface as shown below. The pinouts on the terminal strip interface replicate the pinouts for the hardware module as depicted in the Hardware Manual; i.e., pin 1 on the connector is pin 1 on the module.

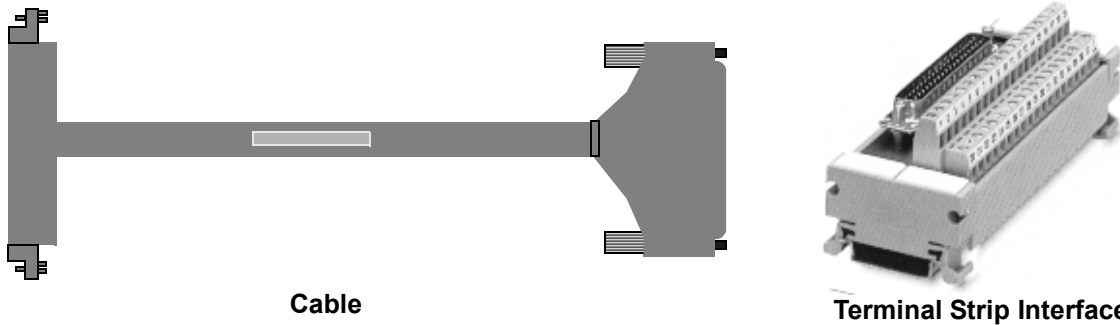

Cable

Terminal Strip Interface

*Cables are 5' in length. Other lengths are available. Consult factory for information.

OPTIONS FOR OUTPUT MODULES				
Voltage	No. of Points	Module Part No.	Order Cable Part No.	Order Terminal Block Interface Part No.
24 VDC Source	32	M.1016.9070 (old # 502-03640-02)	M.1016.9537 (old # 502-04046-05)	M.1016.1595 (old # 401-56417-00)
	16	M.1016.8933 (old # 502-03640-02)	M.1016.9542 (old # 502-04048-05)*	M.1016.1597 (old # 401-56419-00)
24 VDC Sink	16 Clamped 16 Unclamped	M.1016.9127 (old # 502-03674-02)	M.1016.9537 (old # 502-04046-05)*	M.1016.9537 (old # 401-56417-00)
	32 Clamped	M.1016.9130 (old # 502-03674-22)	M.1016.9537 (old # 502-04046-05)	M.1016.9537 (old # 502-056417-00)
	32 Unclamped	M.1016.9133 (old # 502-03674-42)	M.1016.9537 (old # 502-04046-05)	M.1016.9537 (old # 502-056417-00)
120/240 VAC	32	M.1016.9076 (old # 502-03641-03)	M.1016.9537 (old # 502-04046-05)	M.1016.9537 (old # 502-056417-00)
	16	M.1016.8943 (old # 502-03551-03)	M.1016.9542 (old # 502-04048-05)*	M.1016.1597 (old # 401-56419-00)

*This part number is for a 5-foot cable. Other lengths are available. Please consult the factory for information

OPTIONS FOR INPUT MODULES				
Voltage	No. of Points	Module Part No.	Order Cable Part No.	Order Terminal Block Interface Part No.
24 VDC	32 (Sink or Source)	M.1016.9010 (old # 502-03605-00)	M.1016.9532 (old # 502-04043-05)*	M.1016.1596 (old # 401-56418-00)
	16 (Sink or Source)	M.1016.8929 (old # 502-03548-00)	M.1016.9540 (old # 502-04047-05)*	M.1016.1598 (old # 401-56419-01)
12 VDC	32 (Sink or Source)	M.1016.9085 (old # 502-03643-02)	M.1016.9532 (old # 502-04043-05)*	M.1016.1596 (old # 401-56418-00)
120 VAC	16	M.1016.9076 (old # 502-03550-02))	M.1016.9540 (old # 502-04047-05)*	M.1016.1598 (old # 401-56419-01)

*This part number is for a 5-foot cable. Other lengths are available. Please consult the factory for information

Description	New Part Number	Old Part Number
Discrete I/O Wiring Harness Cable for 16DC and 16 AC Inputs	M.1016.9540*	502-04047-05*
Discrete I/O Wiring Harness Cable for 16 DC and 16 AC Outputs	M.1016.9542*	502-04048-05*
Discrete I/O Wiring Harness Cable for 32 DC Inputs	M.1016.9532*	502-04043-05*
Discrete I/O Wiring Harness Cable for 32 DC and 16 AC Outputs	M.1016.9537*	502-04046-05*
Terminal Block for 16-Point Input Modules	M.1016.1598	401-56419-01
Terminal Block for 16-Point Output Modules	M.1016.1597	401-56419-00
Terminal Block for 32-Point Input Modules	M.1016.1596	401-56418-00
Terminal Block for 32-Point Output Modules	M.1016.1595	401-56417-00
PiC900 CPU Battery Backup Module with Battery Test	M.1016.9521	502-04030-00

*This part number is for a 5-foot cable. Other lengths are available. Please consult the factory for information

Battery Backup Board

There is a battery backup board available to use with PiC CPUs. It maintains the memory contents when the CPU is not in a rack; i. e., when it is in transit.

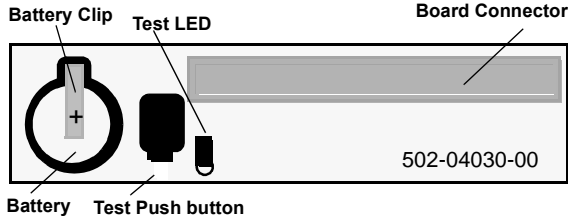

Item	Battery Backup Board Part Number	Replacement Battery
Battery Backup Board with LED and Test Push Button	M.1016.9521 (old # 502-04030-00)	3V Panasonic BR2330 or equivalent

NOTES