

USER MANUAL

PiC9TM DSM Series

GIDDINGS & LEWIS[®]

USER MANUAL

PiC9TM DSM Series

GIDDINGS & LEWIS[®]

NOTE

Progress is an on going commitment at Giddings & Lewis. We continually strive to offer the most advanced products in the industry; therefore, information in this document is subject to change without notice. The illustrations and specifications are not binding in detail. Giddings & Lewis shall not be liable for any technical or editorial omissions occurring in this document, nor for any consequential or incidental damages resulting from the use of this document.

DO NOT ATTEMPT to use any Giddings & Lewis product until the use of such product is completely understood. It is the responsibility of the user to make certain proper operation practices are understood. Giddings & Lewis products should be used only by qualified personnel and for the express purpose for which said products were designed.

Should information not covered in this document be required, contact the Customer Service Department, Giddings & Lewis, 660 South Military Road, P.O. Box 1658, Fond du Lac, WI 54936-1658. Giddings & Lewis can be reached by telephone at (920) 921-7100.

Version 0599

108-31006-50

© 1995, 1996, 1999 Giddings & Lewis

Belden® is a registered trademark of Cooper Industries, Inc.

IBM is a registered trademark of International Business Machines Corp.

Microsoft® and MS-DOS® are registered trademarks of Microsoft Corporation.

MCS is a registered trademark of Intel Coporation.

MODHUB is a trademark of Contemporary Control Systems, Inc.

ARCNET® is a registered trademark of Datapoint Corporation.

ST is a trademark of AT&T Bell Labs.

PiC900, PiC90, PiC9, PiCPro, PiCServoPro, and PiCPro Utilities are trademarks of Giddings & Lewis, Inc.

Table of Contents

CHAPTER 1- PiC9 Hardware/Software

Hardware Introduction	1-1
PiC9 Expansion.....	1-2
The Centurion DSM100 Drive.....	1-3
The PiC9 CPU	1-4
Startup Summary.....	1-5
Mounting Instructions	1-6
PiC9 LEDs/Connectors.....	1-9
Status LEDs	1-10
ARCNET LEDs	1-10
I/O Connections.....	1-13
Analog Output Section	1-14
Analog Output Connections.....	1-14
Analog Output Theory of Operation.....	1-15
Encoder Input Section	1-16
Encoder Drivers	1-16
Encoder Connections	1-17
Incremental Encoders.....	1-19
Encoder Theory of Operation	1-20
24 VDC Input Section.....	1-22
Input Connections	1-22
Input Theory of Operation	1-23
24 VDC Output Section	1-26
Output Connections	1-26
Output Theory of Operation.....	1-27
Protecting Outputs from an Inductive Load.....	1-27
Specification Tables	1-29
Software Setup	1-35
Servo Setup.....	1-35
Hardware Declarations.....	1-36
Software Declarations.....	1-37
Appendix A - Component Installation Procedures	
Preliminary Steps	A-1
Final Steps.....	A-2
System EPROM	A-4
Ladder Memory	A-4
Optional Math Coprocessor	A-5

Replacing the battery on the PiC9	A-5
Optional Flash Memory System (FMSSDISK)	A-6
Replacing a Blown Fuse	A-8

Appendix B - Communications Connections

Communication Topologies.....	B-2
Bus Topology.....	B-2
Star Topology.....	B-2
Distributed Star Topology	B-3
Distributed Star/Bus Topology	B-3
Connectors	B-7
Coax	B-7
Twisted Pair	B-7
Fiber Optics.....	B-8

Appendix C - EMC Guidelines

Background on EMC (Electromagnetic Compatibility) Compliance.....	C-1
RFI Emission and Immunity.....	C-1
Classes of EMC Operating Environments	C-2
Conformance with the EMC Directive	C-3
Changes to the PiC Products.....	C-3
Changes Affecting the User	C-3

PiC9 Hardware/Software

Hardware Introduction

The PiC9 is a member of the PiC900 family of Programmable industrial Computers. The PiC9 consists of a Centurion DSM100 drive and a PiC9 controller board. The PiC9 is programmed using PiCPro Software. It is capable of two axes of motion control (three axes with optional expansion), I/O expansion, and ARCNET communication. The PiC9 package includes the PiC9 controller, the PiC9 Manual, and the DSM100 Drive Manual.

FIGURE 1-1. The PiC9

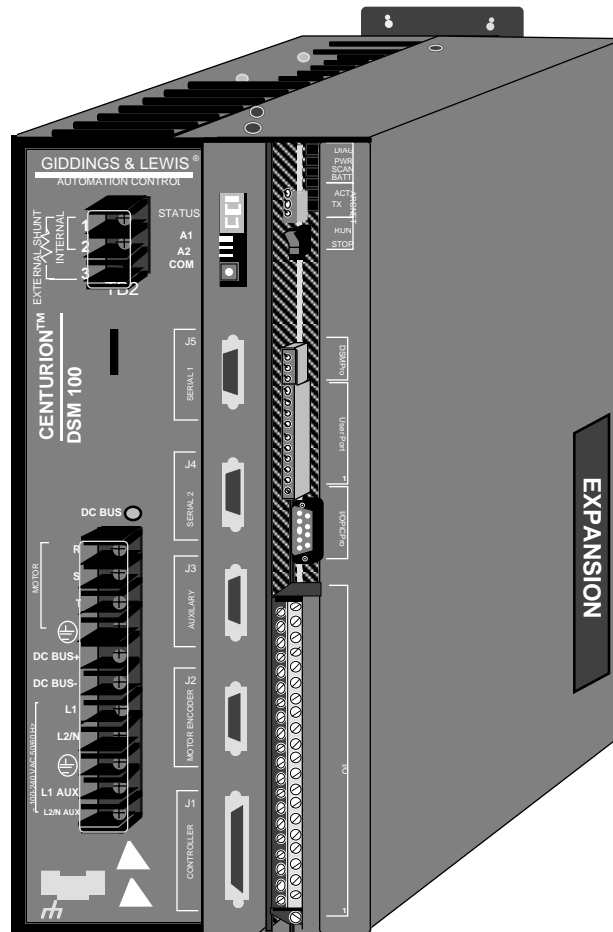

PiC9 Expansion

It is possible to add an expansion rack to the PiC9. The rack holds two hardware modules as shown below. You can select any discrete I/O, analog, servo/feedback, or communication modules from the PiC900 family. The PiC900 Hardware Manual will provide information on the expansion rack modules.

The expansion rack plugs into the expansion slot on the side of the PiC9. The location of the expansion slot is shown in Figure 1-1.

FIGURE 1-2. PiC9 with Expansion Rack

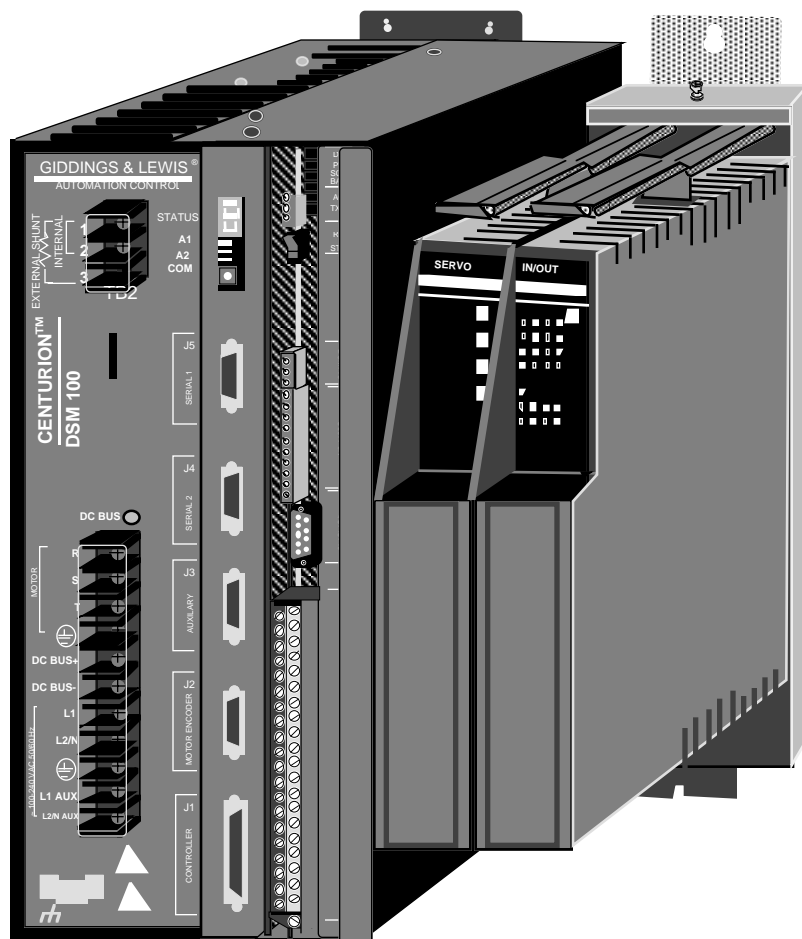

The Centurion DSM100 Drive

Refer to the Drive Manual included with the PiC9 package for information on the DSM100 drive.

IMPORTANT

The 24V DC power supply on the drive is available on the PiC9 I/O connector. *This supply is only available if there is no expansion rack attached to the PiC9.* See **FIGURE 1-5. I/O Screw Terminal Connector** on page 12. As stated in the Drive Manual, there is a total of .5 A available from this 24V supply.

IMPORTANT

Some connections are already made for you between the DSM100 drive and the PiC9. Therefore, no connections should be made to the following connectors on the DSM100 drive.

On connectorJ1:

1. MTR Encoder Outputs - Pins 7 through 12
2. Drive Enable Pin 20
3. Analog Command + and - Pins 22 and 23

The PiC9 CPU

The PiC9 CPU performs the following:

- Performs diagnostic tests.
- Checks the battery.
- Performs routine maintenance tasks.
- Executes the application program.
- Communicates with the drive and with I/O modules.
- Maintains communication with the workstation through the PiCPro port.
- Maintains communication with the user interface device through the user port.

The application program created with PiCPro software and loaded into PiC9 memory will not be scanned until you turn the Run/Stop switch on the PiC9 to the Run position.

CAUTION

The run/stop rocker switch on the PiC9 does not control power to the PiC9. *Always shut off power at the main disconnect switch before you replace a module in the system.*

There is an internal time-of-day clock on the PiC9 which maintains the current date and time. If power is off to the system, the battery maintains the clock. The application program and PiCPro can access this clock. Details are given in the Software Manual.

Startup Summary

Below is a quick overview of what needs to be done to begin operating the PiC9 control.

1. Refer to this manual to mount the PiC9 on your panel.
2. Refer to the DSM100 Manual for the DSM100 power wiring procedure.
3. Refer to this manual to connect any discrete I/O you will be using.
4. Mount the motor.
5. Connect one end of the motor power cable to the drive and the other to the PiC9.
6. Using the proper Giddings & Lewis feedback cable, connect one end of the cable to the motor and the other to the PiC9.
7. Connect a PC to the PiC9 PiCPro Port using the PiCPro cable supplied with the PiCPro software.
8. Turn on power to the PiC9.
9. Refer to the DSM Manual to properly configure the drive for your motor using DSMPro software.
10. Download your PiCPro application program.
11. Start the scan.

Mounting Instructions

Follow the mounting precautions found in the DSM100 Drive Manual when mounting the PiC9. The dimensions for the PiC9 are shown on the next page.

NOTE

If you are adding an expansion rack to a PiC9 that is already mounted, be sure to push the expansion rack connector into the slot on the side of the PiC9 before screwing down the expansion rack mounting bracket.

FIGURE 1-3. Dimensions for Mounting the PiC9 with the DSM 110, 120, or 130 (w and w/o Expansion Rack)

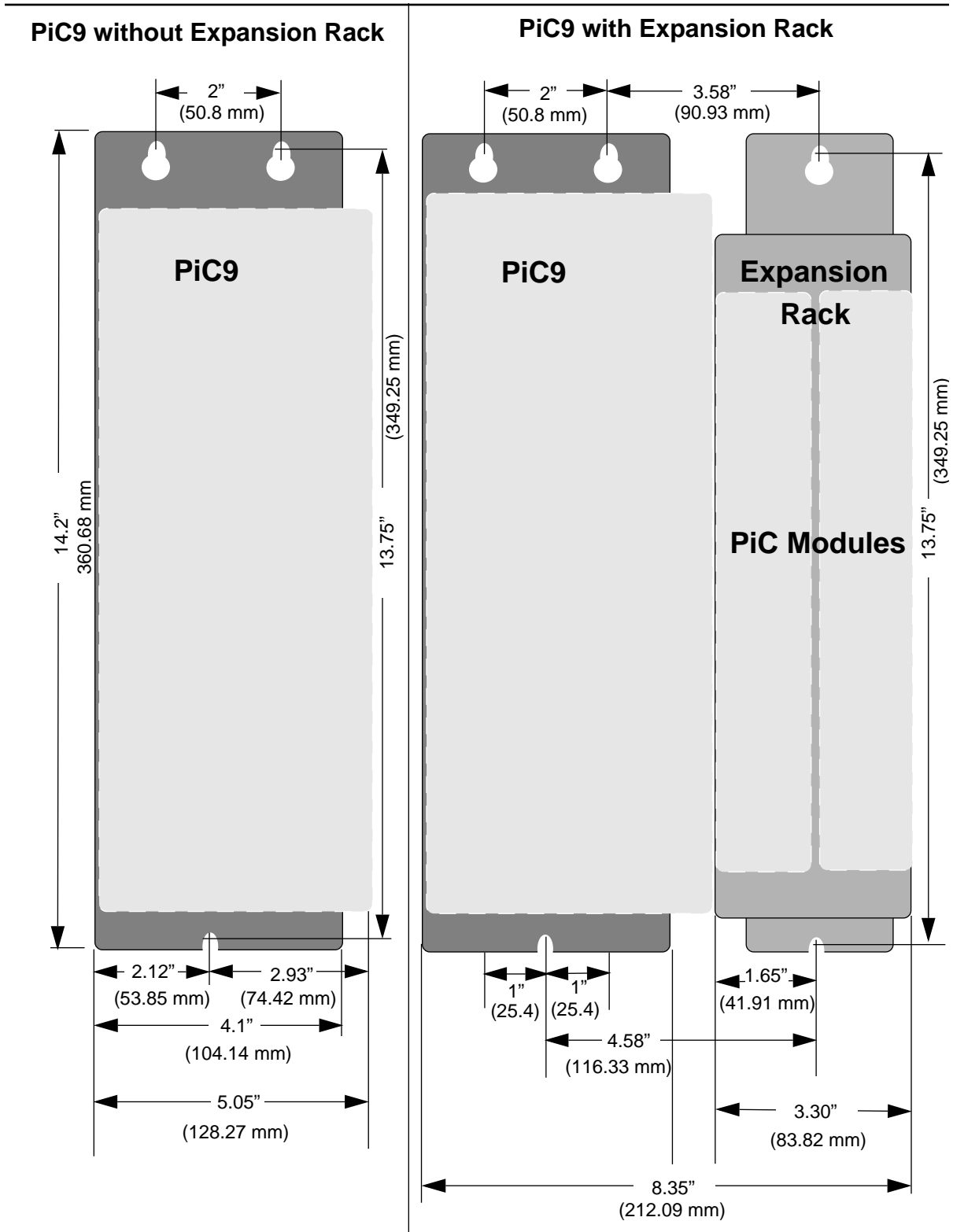

FIGURE 1-4. Dimensions for Mounting the PiC9 with the DSM175
(with and without an Expansion Rack)

The overall dimensions for the PiC9/DSM175 are:

without an expansion rack-10 in x 6.92 in x 14.25 in (254 mm x 175.77 mm x 361.95 mm)

with an expansion rack-10 in x 10.22 in x 14.25 in (254 mm x 259.59 mm x 361.95mm)

PiC9 without Expansion Rack

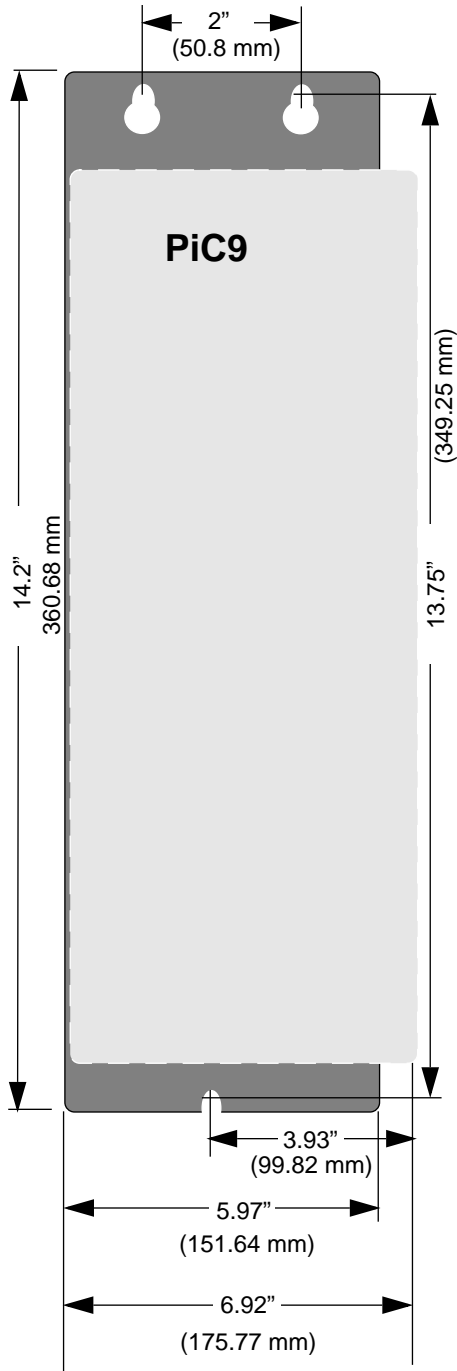

PiC9 with Expansion Rack

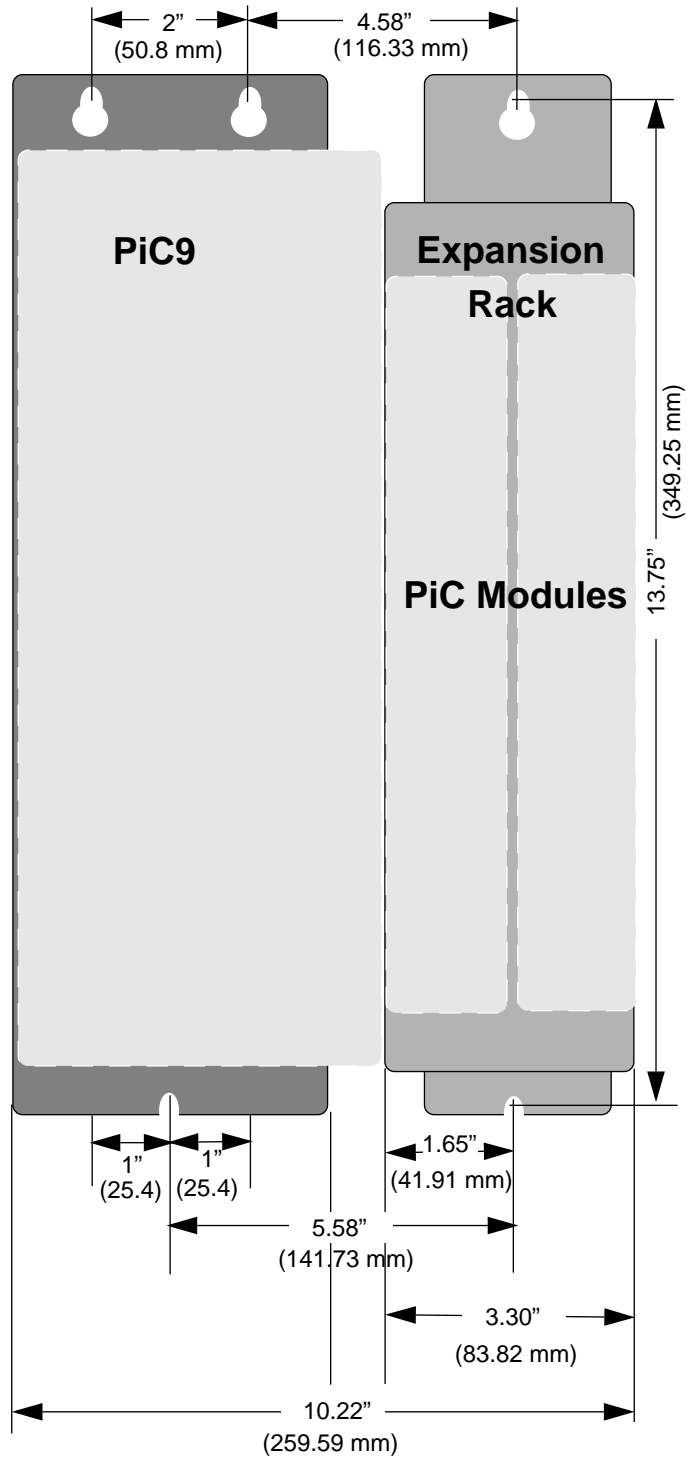

PiC9 LEDs/Connectors

The PiC9 has the following connectors located on the front edge from top to bottom. See **FIGURE 1-1. The PiC9** on page 1.

1. A 3-pin ARCNET connector (optional)
2. A 10-pin user port connector
3. A 9-pin “D” PiCPro connector
4. A 40-pin I/O connector

The ARCNET port has a 3-pin screw terminal connector and provides peer-to-peer communications capabilities. This is optional. See Appendix B for information on connecting PiCs on a network.

The user port has a 10-pin screw terminal connector and communicates with an optional serial interface device such as a touch-screen, a hand-held controller, etc.

The PiCPro port has a 9-pin D connector and communicates with the workstation serial port. This port is used when downloading an application program from the workstation into PiC9 RAM memory. It may also be used while the PiC9 system is running the program in order to exchange data with the workstation.

The 40-pin I/O screw terminal connector provides connections to the following:



1. An analog output (Channel 2)
2. An encoder input (Channel 2)
3. Two fast inputs for encoders (Channel 1 and Channel 2)
4. DC inputs (1 through 12)
5. DC outputs (1 through 6)
6. 24V DC Supply (.5A total) (only available if no expansion rack is installed)

NOTE: This 24V DC supply is coming from the PiC9. Do not hook an external power supply to these pins.

Other internal connections between the PiC9 and the drive include the following:

1. Encoder Channel 1 receives its signals from the MTR Encoder In pins on the drive’s J2 connector.
2. Analog Output Channel 1 controls the velocity command (Analog Command + and -) inputs on the drive.
3. DC Output 7 controls the Drive Enable signal on the drive.
Turning this output on enables the drive.
4. DC Output 8 controls the source of the user port.
When this output is off, data is sent to/from the 10-pin connector.
When this output is on, data is sent to/from the 3-pin connector which is typically wired to the serial port connector on the drive.
5. DC Input 16 is connected to the Drive Ready Signal on the drive.
When this input is on, there are no active faults and the drive is functioning properly.

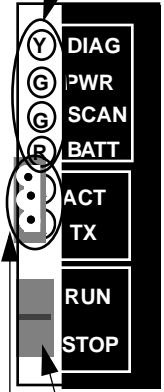
The next section describes the connections on the front of the PiC9.

PiC9 LEDs/ Connectors	Descriptions
<div style="display: flex; flex-direction: column; align-items: center;"> <div style="margin-bottom: 20px;"> <p>Status LEDs</p>  </div> <div style="margin-bottom: 20px;"> <p>ARCNET LEDs</p> </div> <div style="margin-bottom: 20px;"> <p>The scan RUN/STOP rocker switch controls the program loaded in the PiC9.</p> </div> </div>	<p>Status LEDs</p> <p>The first four LEDs located at the top of the PiC9 indicate the status of the system.</p> <p>Diagnostic LED - DIAG</p> <p>The yellow DIAG LED should turn on briefly whenever power is turned on to the system. The PiC9 automatically runs diagnostic tests on all modules at power up. The DIAG LED goes on during testing and turns off when the module passes all the tests.</p> <p>Power LED - PWR</p> <p>The green PWR light should be on all the time that power is on to the system. It indicates that the + 5V supply is within tolerance. See the specification sheet.</p> <p>Scan LED - SCAN</p> <p>The green SCAN light indicates that the processor is executing the application program. If scan loss occurs the light will go off and the PiC9 performs an orderly shutdown.</p> <p>Battery LED - BATT</p> <p>The red BATT light should turn on briefly while the battery is checked at power-on. After the battery passes its test, the LED goes off. If the battery LED starts flashing either at start-up or during system operation, the lithium battery must be replaced. The PiC9 controller and any expansion module that uses the battery to back up its data has circuitry that can maintain its data for approximately two hours if the battery is not in the PiC9. Power must be on for at least five minutes to ensure that data will be retained when the battery is removed.</p> <p>ARCNET 3-Pin Connector</p> <div style="text-align: center; margin: 10px 0;">  <p>ARCNET twisted pair interface</p> </div> <p>ARCNET LEDs</p> <p>The next two LEDs indicate the status of the optional ARCNET communications.</p> <p>Active LED - ACT</p> <p>The red ACT LED indicates the ARCNET active status. If it is off, no data is being transferred. If it is flashing on, data is being transferred to/from the ARCNET interface.</p> <p>Transmit LED - TX</p> <p>The red TX LED indicates the ARCNET transmit status. If it is off, it is not an active part of the network. If it is on, there is normal network activity. If it is flashing, the network is being reconfigured.</p>







PiC9 LEDs/ Connectors	Descriptions																																			
	<p>User Port</p> <table border="0"> <thead> <tr> <th></th> <th style="text-align: center;"><u>Pins</u></th> <th style="text-align: center;"><u>In/Out</u></th> </tr> </thead> <tbody> <tr> <td rowspan="10">  <p>LEDs</p> <p>(R) On when the user port is transmitting data.</p> <p>(R) On when the user port is receiving data.</p> </td> <td>10</td> <td>Transmit Data</td> <td>Out</td> </tr> <tr> <td>9</td> <td>Receive Data</td> <td>In</td> </tr> <tr> <td>8</td> <td>Signal Ground</td> <td>In/Out</td> </tr> <tr> <td>7</td> <td>Clear to Send</td> <td>In</td> </tr> <tr> <td>6</td> <td>Not Connected</td> <td>----</td> </tr> <tr> <td>5</td> <td>Request to Send</td> <td>Out</td> </tr> <tr> <td>4</td> <td>Data Terminal Ready</td> <td>Out</td> </tr> <tr> <td>3</td> <td>5 Volts</td> <td>Out</td> </tr> <tr> <td>2</td> <td>+12 Volts</td> <td>Out</td> </tr> <tr> <td>1</td> <td>-12 Volts</td> <td>Out</td> </tr> </tbody> </table>		<u>Pins</u>	<u>In/Out</u>	 <p>LEDs</p> <p>(R) On when the user port is transmitting data.</p> <p>(R) On when the user port is receiving data.</p>	10	Transmit Data	Out	9	Receive Data	In	8	Signal Ground	In/Out	7	Clear to Send	In	6	Not Connected	----	5	Request to Send	Out	4	Data Terminal Ready	Out	3	5 Volts	Out	2	+12 Volts	Out	1	-12 Volts	Out	
		<u>Pins</u>	<u>In/Out</u>																																	
	 <p>LEDs</p> <p>(R) On when the user port is transmitting data.</p> <p>(R) On when the user port is receiving data.</p>	10	Transmit Data	Out																																
9		Receive Data	In																																	
8		Signal Ground	In/Out																																	
7		Clear to Send	In																																	
6		Not Connected	----																																	
5		Request to Send	Out																																	
4		Data Terminal Ready	Out																																	
3		5 Volts	Out																																	
2		+12 Volts	Out																																	
1		-12 Volts	Out																																	
<p>PiCPro Port</p> <table border="0"> <thead> <tr> <th><u>In/Out</u></th> <th><u>Pins</u></th> <th></th> <th><u>Pins</u></th> <th><u>In/Out</u></th> </tr> </thead> <tbody> <tr> <td>Out</td> <td>+12 Volts</td> <td>6</td> <td rowspan="5">  </td> <td>1</td> <td>5 Volts</td> <td>Out</td> </tr> <tr> <td>Out</td> <td>Request to Send</td> <td>7</td> <td>2</td> <td>Receive Data</td> <td>In</td> </tr> <tr> <td>----</td> <td>Not Connected</td> <td>8</td> <td>3</td> <td>Transmit Data</td> <td>Out</td> </tr> <tr> <td>Out</td> <td>-12 Volts</td> <td>9</td> <td>4</td> <td>Data Terminal Ready</td> <td>Out</td> </tr> <tr> <td></td> <td></td> <td></td> <td>5</td> <td>Signal Ground</td> <td>In/Out</td> </tr> </tbody> </table>	<u>In/Out</u>	<u>Pins</u>		<u>Pins</u>	<u>In/Out</u>	Out	+12 Volts	6		1	5 Volts	Out	Out	Request to Send	7	2	Receive Data	In	----	Not Connected	8	3	Transmit Data	Out	Out	-12 Volts	9	4	Data Terminal Ready	Out				5	Signal Ground	In/Out
<u>In/Out</u>	<u>Pins</u>		<u>Pins</u>	<u>In/Out</u>																																
Out	+12 Volts	6		1	5 Volts	Out																														
Out	Request to Send	7		2	Receive Data	In																														
----	Not Connected	8		3	Transmit Data	Out																														
Out	-12 Volts	9		4	Data Terminal Ready	Out																														
				5	Signal Ground	In/Out																														
<p>I/O Port</p> <p>The PiC9 I/O section has a 40-pin screw terminal connector. See FIGURE 1-5. I/O Screw Terminal Connector on page 12. Their descriptions follow.</p>																																				

FIGURE 1-5. I/O Screw Terminal Connector

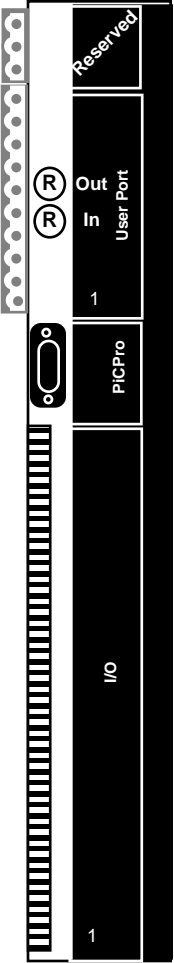

I/O Connections

Several signals to the 40-pin connector must come to the screw terminals through shielded twisted pair wires. Shielded twisted pair wire is used to connect:

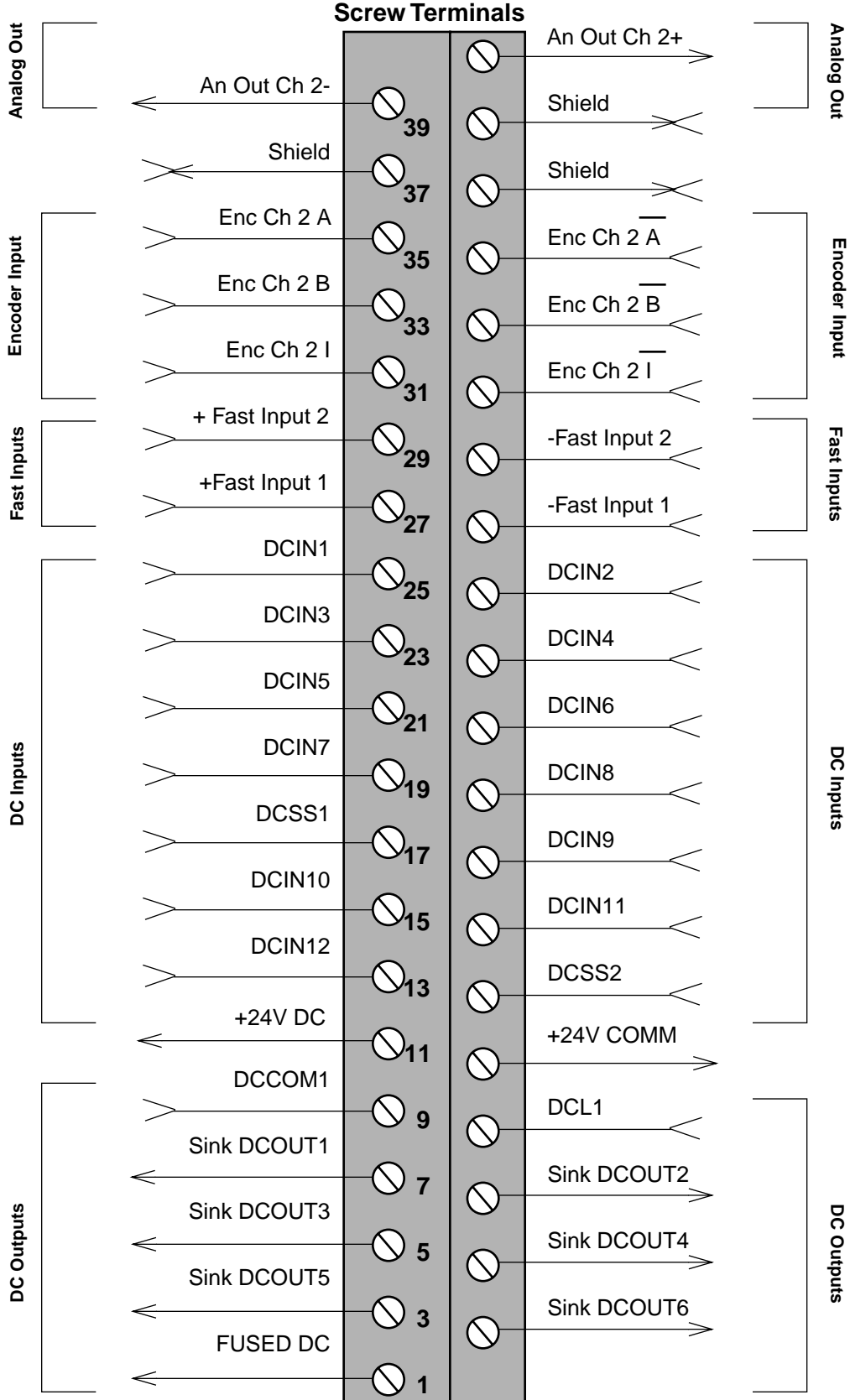
- Analog output channel 2 to a receiving device
- Channel 2 encoder signals to the PiC9
- Both fast input signals to the PiC9

These wires must be protected against electrical noise because of the speed and/or voltage levels of the signals transmitted through them.

The module has three screw terminal connections for terminating the shields. All three are connected together inside the module, so they are the same point electrically.

The connections to the individual sections of the I/O screw terminal connector are covered in the sections that follow.

NOTE
Whenever the I/O connections require an external 24V DC supply, you can use the supply available on pins 10 and 11 provided there is no expansion rack in the PiC9 system. There is a total of .5A available from this supply.

Analog Output Section

There are two analog output channels on the PiC9. Channel 1 is connected internally to the velocity command inputs (Analog Command + and -) of the drive. Channel 2 is available on the screw terminal connector.

Analog Output Connections

You may connect a differential type output from the analog output to a differential (Figure 1-5) or single-ended (Figure 1-6) input device.

FIGURE 1-6. Connections to a Differential Device

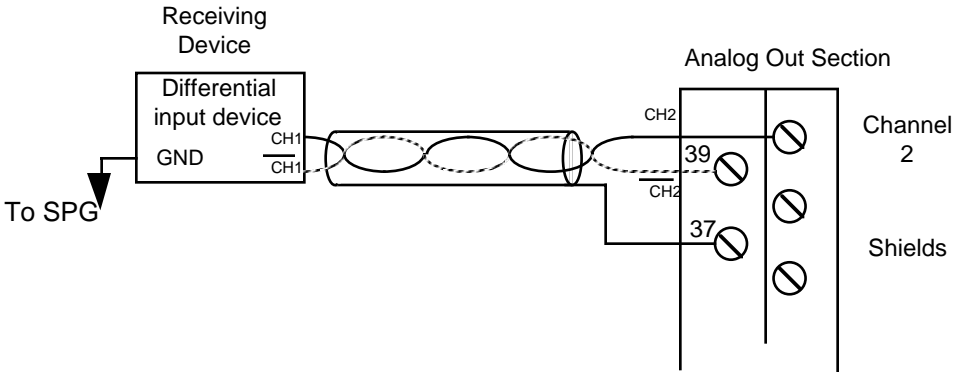

Note that one wire in the twisted pair is connected to the 0 V terminal on the single-ended receiving device. This 0V terminal must be referenced to the SPG through the device's ground connection.

FIGURE 1-7. Connections to a Single-Ended Device

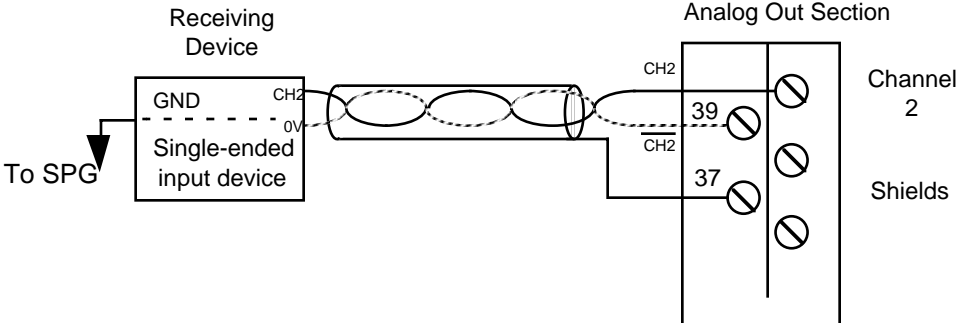

Analog Output Theory of Operation

The PiC9 sends the analog output section a 16-bit digital word for the analog output channel. Each digital word is converted to a corresponding voltage within the range of ± 11 V. The voltage is buffered and brought out to a pair of screw terminal connections as a differential type voltage output. This output is less subject to interference from electrical noise than a single-ended output would be.

You can adjust the analog output channel in software for offset adjustments, gain scaling, and unipolar outputs.

For safety reasons, the output is automatically reset to 0 V when a scan loss condition occurs.

Encoder Input Section

There are two encoder channels on the PiC9. Encoder Channel 1 is internal and receives its signals from the MTR Encoder In pins on the drive's J2 connector. The Channel 1 fast input is found on the screw terminal connector. See **FIGURE 1-5. I/O Screw Terminal Connector** on page 12.

Encoder Channel 2 is found on the screw terminal connector. The encoder channel has four signal pairs, each of which has two screw terminal connections. The signal pairs are:

Encoder Input A
Encoder Input B
Index Input
24 VDC Fast Input

IMPORTANT

The power supply to the encoder (or signal source device) must have its common connected to the Single Point Ground.

If the 24 VDC "fast" input is used, its power supply common must also be connected to the Single Point Ground.

Encoder Drivers

Information from the encoders is used to update four separate position counters and latches within the module. For each channel, a 24-bit counter is incremented or decremented based on signals it receives from the A and B outputs of an encoder. The counter value can be latched (stored) if the module receives either an "index" signal from the encoder or a 24 VDC "fast" input signal.

Acceptable drivers provided by encoder manufacturers include:

Differential voltage drivers	75183 8830 75114 9614 7513 26LS31
Single-ended open collector drivers	7406

339 type output devices will not work because their output current level is too low.

NOTE

Encoders with differential drivers are strongly recommended. They provide better noise immunity and capability for the module to detect “loss of feedback”.

See **Appendix C Electrical Noise Reduction** for a comparison of signals from differential and single-ended drivers.

Encoder Connections

If the encoder has differential output drivers as shown in Figure 1-7, the three encoder outputs are paired:

A and \overline{A}
 B and \overline{B}
 index and $\overline{\text{index}}$

FIGURE 1-8. Wiring from an Encoder with Differential Drivers

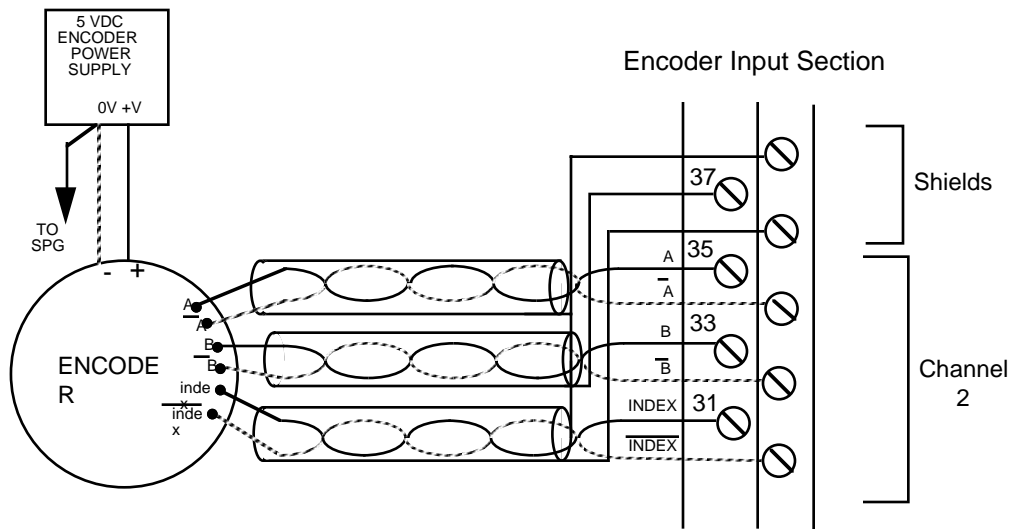

If an encoder has single-ended drivers, there are three single outputs: A, B, and index. Each output is referenced to the + V terminal of the encoder power supply. See Figure 1-8.

FIGURE 1-9. Wiring from an Encoder with Single-Ended Drivers

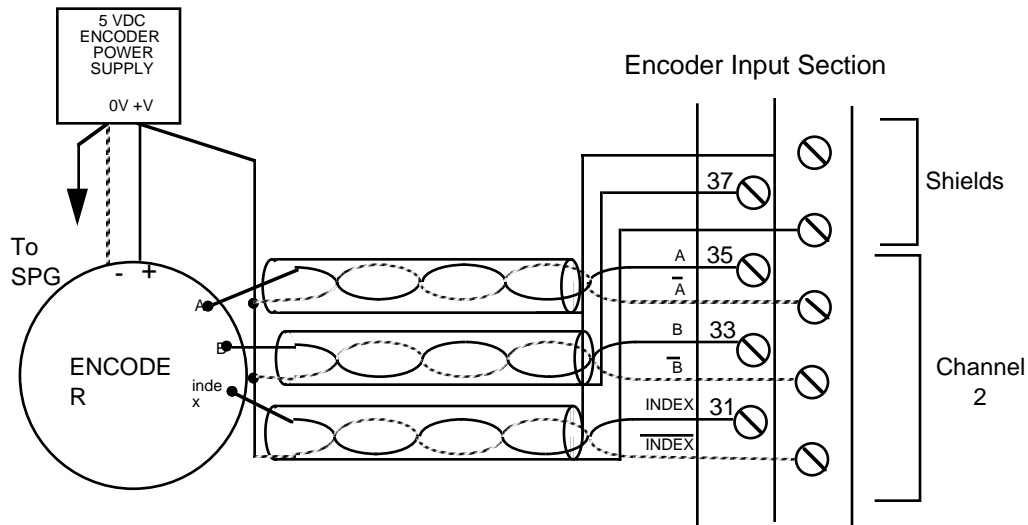

IMPORTANT

The minimum width signal that can be accepted by the encoder section is 0.6 μ seconds.

The signal at output A or B from the encoder has a frequency that is the product of the resolution of the encoder in pulses (lines) per revolution and the speed of the encoder in revolutions per second.

Thus an encoder that generates 2,000 pulses (lines) per revolution and rotates at 10 revolutions per second generates 20,000 pulses (lines) per second. In a quadrature type encoder, the interface module would supply 80,000 Feedback Units per second.

Encoder Input Section

Fast inputs are connected as shown in Figure 1-9. Either fast input can be connected as sink or source.

FIGURE 1-10. Fast Input Connections

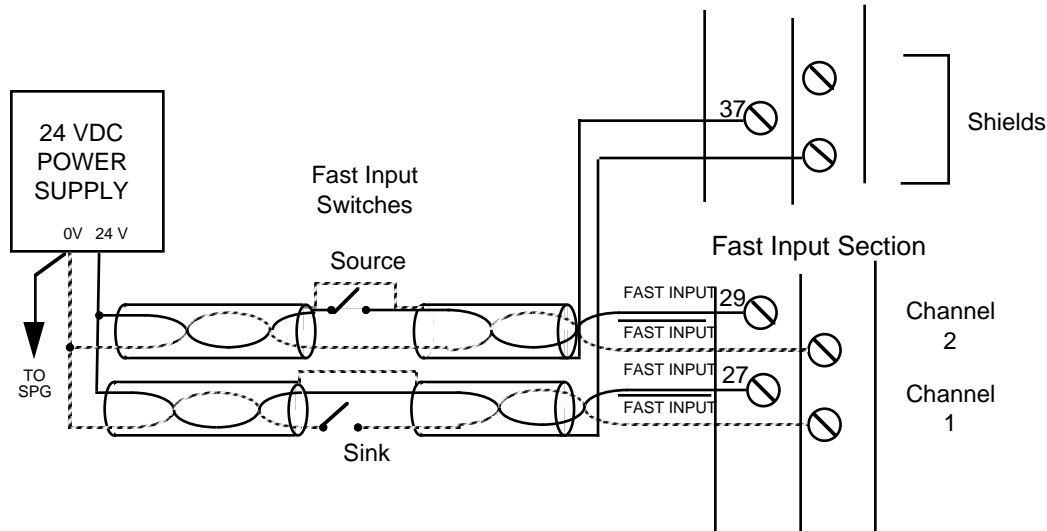

Incremental Encoders

An *incremental encoder* is a position transducer. It transmits quadrature or pulse type signals through its “A” and “B” outputs with a frequency proportional to the rotational velocity of its shaft. It transmits a pulse through its index output once per revolution of the device.

There are two types of incremental encoders, quadrature and pulse. Giddings & Lewis recommends quadrature type encoders, which are the most commonly used.

A *quadrature encoder* sends square wave type signals. When the shaft rotates at a constant velocity, the A and B outputs are square waves and are at the same frequency. However they are out of phase with each other by 90°. When the encoder shaft rotates in one direction, each A pulse leads the corresponding B pulse by 90°. When it rotates the other direction each A pulse lags its B pulse by 90°.

The signals illustrated in Figure 1-10 indicate that the encoder shaft rotates in one direction at first. Its speed of rotation decreases to 0 and then it starts rotating the other direction. The signals are shown as differential. \overline{A} is the inverse of the signal A and \overline{B} is the inverse of signal B.

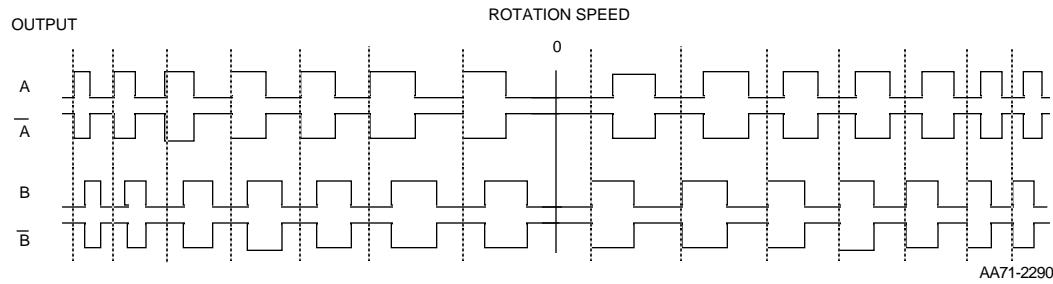
FIGURE 1-11. Signals Transmitted by a Quadrature Encoder with Differential Outputs

A *pulse encoder* sends pulses through output A for one direction of its shaft rotation, and output B for the other direction. When the shaft is not rotating, no pulse is generated.

The signals illustrated in Figure 1-11 indicate that the encoder shaft rotates in one direction at first. Its speed of rotation decreases to 0 and then it starts rotating the other way. The signals are shown as differential, with \overline{A} the inverse of signal A and \overline{B} the inverse of signal B. A pulse encoder may alternate signals at its two outputs, but it cannot send signals from both outputs at the same time.

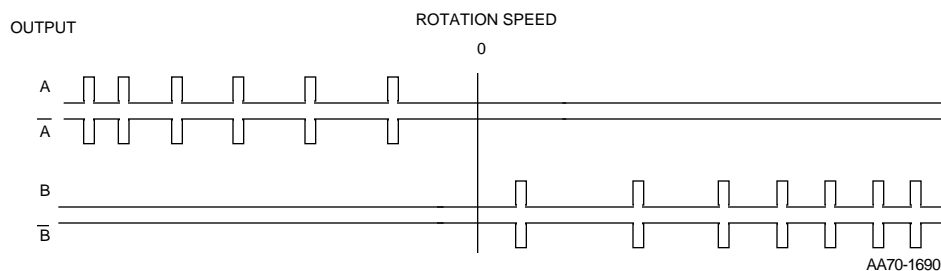
FIGURE 1-12. Signals Transmitted by a Pulse Encoder with Differential Outputs

Encoder Theory of Operation

The encoder section uses differential type inputs to interface with an incremental encoder. These inputs are optically isolated and current limited.

- From a quadrature type, the maximum input frequency is 250,000 lines per second, which results in 1,000,000 Feedback Units (FUs) per second in the encoder module.

FIGURE 1-13. Counting Quadrature Pulses

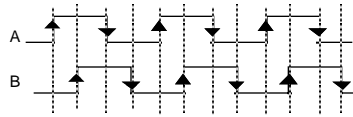

The module counts positive and negative transitions at both channel A and channel B. One quadrature cycle in this case gives four Feedback Units.

- From a pulse type, the module can accept up to 500,000 pulses per second at either input.

There is a 24-bit up/down counter on the PiC9. It is incremented or decremented in accordance with the counting mode selected. There is also a 24-bit latch associated with each encoder channel.

The module can be programmed so that the counter value is “latched” or stored under one of these conditions:

- An index pulse from the encoder
- A positive or negative transition of the fast input
- The next index pulse after the required transition of the fast input

The 24-bit latch has a fast 24 VDC input associated with it. Each input is optically isolated. This input is intended to receive a signal from a device other than an encoder. It is typically used for referencing or synchronization purposes.

Fast input characteristics include:

- The detection of a signal occurs faster than it does for the DC inputs in other modules, due to less filtering. Because of this there is also less noise immunity.
- The response to a fast input signal is independent of ladder scan time. The module can be programmed to latch a position count as soon as this input is detected.

24 VDC Input Section

The input section of the PiC9 converts DC signals from 12 devices into logic levels that the PiC9 can use. Each signal is converted into a corresponding logic 1 or 0 which is transmitted to the PiC9. An “on” signal is nominally 24 VDC, but can be any level between 14 and 30 volts. An “off” signal is any level below 5V. The wiring configurations may be sink or source.

Input Connections

A screw terminal connector is provided for each input and for each external power supply connection. The inputs are isolated in two groups [one group of eight (1-8) and one group of four (9-12)], with one additional terminal per group for the DC source/sink connection (DCSS1 and DCSS2). The devices connected to terminals in the same group have a common DC supply and are wired in the same configuration, sink or source.

Figure 1-13 illustrates two groups of inputs using the same power supply.

Each group can work independently of the other; one group may be sink and the other source. The DC power supply for each group may be different if required. Typically just one DC power supply is used, daisy-chained from one group to the next.

The first group of eight inputs is shown with devices “sinking” current through the module. The HOT (V+) terminal of the power supply must be connected to the module at DCSS1. The second group of four inputs are shown with devices “sourcing” current through the module. The COMMON (0V) terminal of the power supply must be connected to the module at DCSS2. In this example the DC power supply is the same for both groups.

FIGURE 1-14. Connectors for Two Groups of Inputs

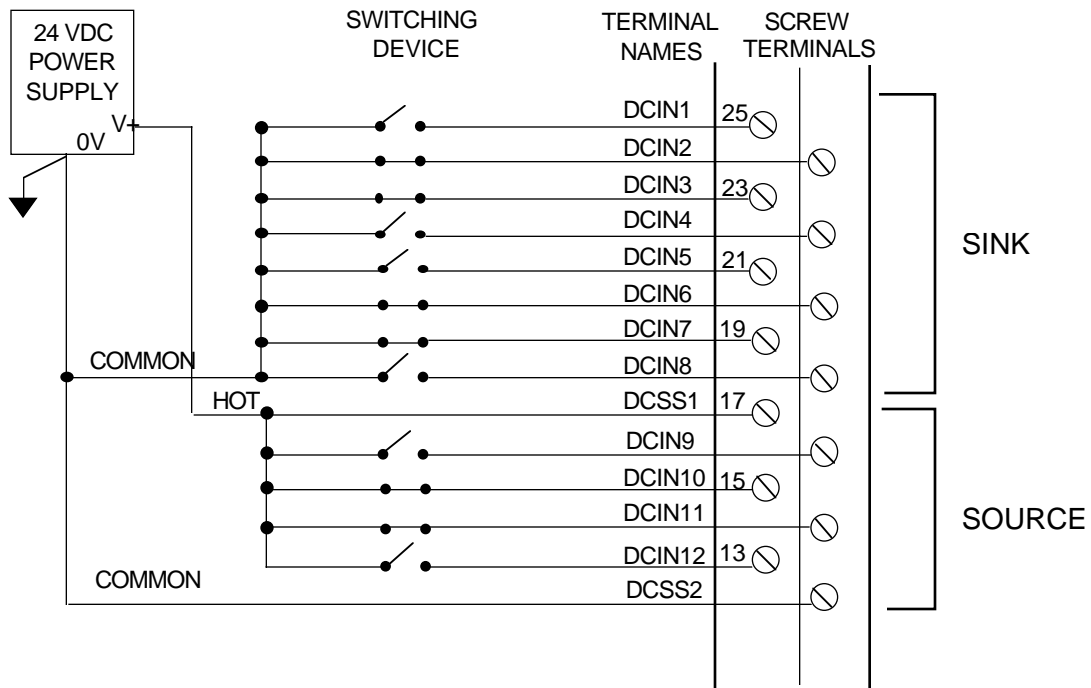

Input Theory of Operation

Each input is guaranteed “on” at 14 to 30 VDC and guaranteed “off” at 0 to 5 VDC. This is polarity independent. Its on/off state is converted to a corresponding logic 1 or 0. This logic state is transmitted through the system bus to the CPU module where the processor uses it as data in the ladder program. The logic side of the input is optically isolated from the field side.

If you need to know whether voltage is present at the field side, use a voltmeter on the terminal screws.

The shaded blocks show the limits specified by the IEC. The lines show the maximum and minimum V/I of the inputs in this module. The voltage/current curve in this graph shows that the input module is well within the IEC Type 1 limits.

FIGURE 1-15. Input Characteristics Compared to IEC Standards

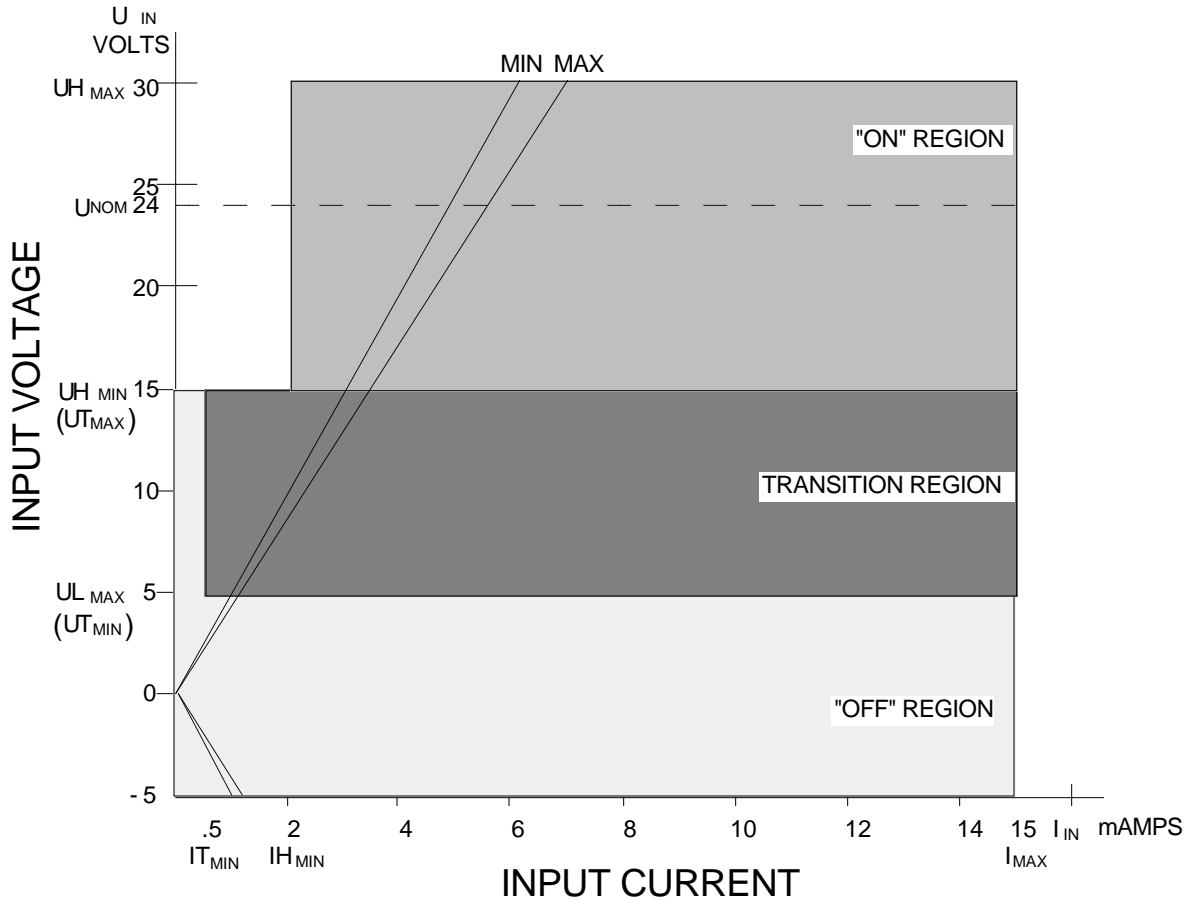

IMPORTANT

Switching devices can sometimes have a leakage current that exceeds the IT (current allowed when off) of an input module. In order to use such a device, an impedance (typically, a resistor) needs to be used in parallel with the input.

For example, some of the newer proximity switches use two wires instead of three. The third wire was used for a power or ground line. Without the third wire, the switch is easier to install. However, it requires more leakage current in the off state to power its internal circuitry.

Use the following formula to calculate the size of the necessary resistor:

$$\frac{2.4\text{VDC}}{\text{Switch Leakage} - .75\text{mA}} \geq R$$

If the switch leakage specification $\leq 1.7\text{mA}$, then:

$$\frac{2.4\text{VDC}}{1.7 - .75\text{mA}} \geq 2.5\text{K } \Omega$$

Use a $2.4\text{K } \Omega$, $1/2\text{W}$ or any lower resistance and higher wattage resistor. Be sure that the wattage is adequate for the resistor remembering that:

$$P = \frac{\text{VDC}^2}{R}$$

24 VDC Output Section

The output section of the module sinks voltage for six individual loads from one DC power supply. The external supply is nominally 24 volts, but can be between 5 and 32 volts.

Output Connections

A screw terminal connection is provided for each output. The outputs are isolated in one group of six with one additional terminal (FUSED DC) for the DC fused supply (DCL1). Figure 1-15 shows the connections for the outputs.

One terminal is provided for DC common and one terminal is provided for the DC supply input. The DC supply input is a fused circuit and returns to a terminal for field use. Figure 1-15 shows the internal fuse circuitry in the shaded box.

FIGURE 1-16. Connections for Outputs

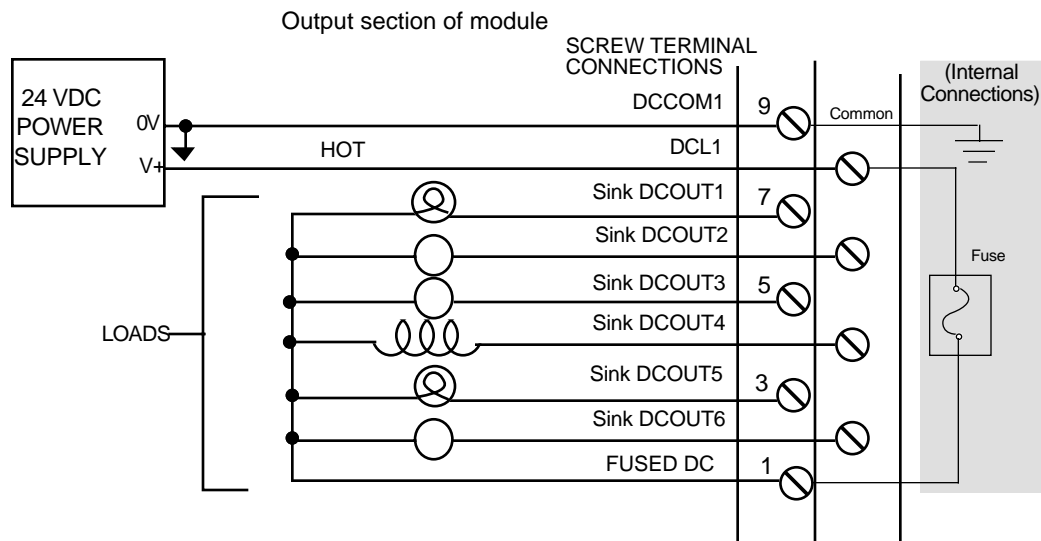

IMPORTANT

Do not connect the DC HOT (DCL) and COMMON (DCCOMMON) to the group unless you plan to use one or more of its outputs.

The external DC supplies that power the input and output signals should have a wire connected from their 0V (COMMON) terminal directly to the single-point ground used for the PiC9. Their power disconnect switch should be the same one used for the PiC9.

Output Theory of Operation

Each output point is a solid state switch rated at 4 A. It turns on or off according to the logic state sent to it by the PiC9. If the PiC9 sends it a logic 1, the switch closes and the load is provided a path to common. If the PiC9 sends a logic 0, the switch opens and power to the load is cut off. The PiC9 updates the logic state for each switch every time it scans the program.

The logic side of the switch is optically isolated from the field side. If you need to know whether voltage is actually present at the field side, use a voltmeter on the terminal screws.

A fuse in series with the source protects against current overload in case the outputs are shorted to ground. See Appendix A for information on changing a blown fuse.

Protecting Outputs from an Inductive Load

The outputs should be used for non-inductive loads such as resistive or electronic loads. Resistive loads can be connected to the module and controlled by the system with no precautions other than making sure they have a connection to the DCOUT fused supply. When an output is energized, current passes through the load into the common line. When the output is de-energized, current stops. The state of the outputs is controlled by the CPU module.

Inductive loads have an electrical “kickback” when current is stopped. This can damage or destroy the output switching device. When the output is turned off, the inductive field collapses. This creates a reverse voltage across the load called “kickback” which tries to continue the current. The voltage is in series with the DC power supply. The combined voltage appears across the output switching device in

the module. If this were the only path available, voltage across the device would peak at several hundred volts.

IMPORTANT
If inductive loads need to be connected to the outputs, an external diode must be connected between the load and FUSED DC as shown below.

FIGURE 1-17. Connecting an External Diode

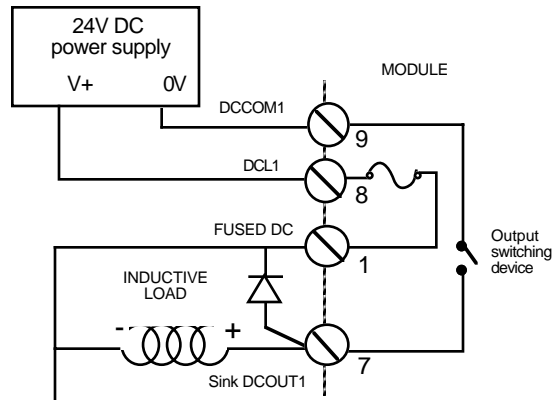

Specification Tables

Characteristic		PiC9 specifications Executes the application program. Executes Diagnostics on the system and its modules. Communicates through the RS232 ports to external devices. Option: Peer-to-peer communication with PiC900 family of controls									
Functions											
Models available						Number of servo axes available at six update rates*					
Model	Drive	Part Number	Speed	App Mem	RA M Mem	8 ms	4 ms	2 ms	1 ms	.5 ms	.25 ms
Turbo	DSM110-10A	503-25187-01	16 MHz	256K	128K	3	3	3	2	1	0
w/ARCNET	DSM110-10A	503-25187-11	16 MHz	256K	128K	3	3	3	2	1	0
Turbo	DSM120-20A	503-25188-01	16 MHz	256K	128K	3	3	3	2	1	0
w/ARCNET	DSM120-20A	503-25188-11	16 MHz	256K	128K	3	3	3	2	1	0
Turbo	DSM130-30A	503-25189-01	16 MHz	256K	128K	3	3	3	2	1	0
w/ARCNET	DSM130-30A	503-25189-11	16 MHz	256K	128K	3	3	3	2	1	0
Turbo	DSM175-75A	503-25768-01	16 MHz	256K	128K	3	3	3	2	1	0
w/ARCNET	DSM175-75A	503-25768-11	16 MHz	256K	128K	3	3	3	2	1	0
Optional Expansion Rack		503-25164-02									

*The number of axes listed is typical for RATIO_GR, RATIOCAM, VEL_STRT, POSITION and DISTANCE move types. Applications which use time axes, servo tasks, RATIO_RL, M_LINCIR, or M_SCRVLC moves require more CPU time and may reduce the number of axes that can be controlled at that rate. Consult Giddings & Lewis for assistance if you want to exceed the number of axes in this chart.

24V power available on pin 11 of the PiC9 controller I/O connector and/or J1-5 and J1-26 connectors on the drive	No expansion rack installed.	.5A total	
	Expansion rack installed.	0A	
Current output from 5 and 12V pins	PiCPro Port+12VPin# 6	100mA] 100mA Total
	User Port +12VPin# 2	100mA	
	PiCPro Port-12VPin# 9	100mA] 100mA Total
	User Port -12VPin# 1	100mA	
	PiCPro Port +5VPin# 1	100mA] 250mA Total
User Port +5VPin# 3	100mA		
Drive J1 +5VPin# 1, 3	See drive manual.		

Power to expansion modules	15 W
Individual outputs	+ 5 V @ 3.0 A + 15 V @ 0.5 A -15 V @ 0.5 A
Battery	1.2 Ah 3V, 2/3A lithium battery
+ 5 V supply monitor	Low trip point 4.50V min 4.75V max High trip point 5.50V min 5.94V max PWR LED goes off and PiC9 shuts down
Flash memory system board (FMSDISK)	4 Megabyte FMS Board 502-03882-00 8 Megabyte FMS Board 502-03882-20
Math coprocessor (optional)	Numeric coprocessor Part Number 401-54187-10
PiCPro port (to workstation)	RS232 serial port, secured protocol Software selectable baud rate (300 to 57600 baud)
User port (to serial interface device)	RS232 serial port Supports RTS/CTS hardware handshaking Baud rates to 19.2 K
Peer-to-peer communications	Allows for communication between PiC9s and/or PiC90s/ PiC900s (up to 255) A dedicated network controller supports peer-to-peer communications. Provides a twisted pair wire interface that is transformer isolated. Data is transferred serially at a rate of 2.5 megabits per second.
Twisted pair wire	24 or 26 AWG solid or 26 AWG stranded IMPORTANT Use of other wire sizes may result in an impedance mismatch that could disable communications with some or all nodes on a network when doing peer-to-peer communications.
Time-of-day clock	Access via PiCPro or application program.
Clock tolerance	At 25° C, ±1 second per day Over temperature, voltage and aging variation, +2/-12 seconds per day
Battery power draw when powered down	5 µA @ +3V
Temperature range	7 to 55° C (45 to 131° F)
Humidity	0 to 95%, non-condensing

Specification Tables

EMC Compliant Emissions Noise immunity	Operates with emissions below EN55011/ CISPR 11 Class A limits Immune to: <ul style="list-style-type: none">• Electrostatic discharge (4K V contact mode) per IEC1000-4-2• RF electromagnetic fields per IEC 1000-4-3• Electrical fast transients per IEC 1000-4-4 on incoming power lines Refer to the EMC Guidelines for more information.
Physical size of drive/PiC9	10 in x 5.05 in x 14.25 in (254 mm x 128.27 mm x 361.95 mm)
Physical size with expansion module	10 in x 8.275 in x 14.25 in (254 mm x 210.19 mm x 361.95 mm)

Characteristic	Encoder/analog out specifications
Field side power dissipation, worst case	7.4 W
Analog Output Section (2 ch)	
Function	Converts a 16-bit digital word into a $\pm 11\text{V}$ analog output signal for each of two channels
Resolution	16 bits, or 65536 steps over the full output range
Output voltage characteristics	
Nominal voltage range	$\pm 11\text{ VDC}$
Voltage accuracy @ 11 V	$\pm 5\%$
Output current, max. @ $\pm 10\text{V}$	$\pm 10\text{ mA}$
Output update time increment	32 μsec
Output voltage after power up	$0\text{ V} \pm 20\text{ mV}$
Response to “scan loss”	All outputs reset to $0\text{ V} \pm 20\text{ mV}$
Output ripple	$< 10\text{ mV}_{\text{RMS}}$ at 30 KHz
Short circuit protection	Current limited outputs
Response to scan loss	All outputs are reset to the OFF state
Encoder Input Section	
Function	Counts pulses from two encoders Latches the counter value at an index or 24 VDC input event
Input Encoder (A, B, and index)	Differential or single ended; differential recommended
Guaranteed on, min	2.5 VDC @ 2.5 mA
Input voltage, max	7 VDC
Input current, max	22 mA @ 7 VDC
Signal pulse width, min	.6 μs (600 ns)
Quadrature signal frequency, max	250 KHz for A or B input (1 M FU count rate)
Pulse encoder signal frequency, max	500 KHz for A or B input (500 KFU count rate)
Encoder device	1. Quadrature type incremental encoder (recommended) 2. Pulse type incremental encoder
Stored position value range	24-bit up/down counter 24-bit latch

Specification Tables

Fast input	Nominal 24 VDC, switched externally to the module Active high or low Reverse polarity protected
Voltage max	30 VDC
Guaranteed on	15 VDC
Guaranteed off	5 VDC
Input impedance	2.7 K
On/off time, max	50 μ s
Cable length, max	200 ft. @ 250 KHz and 45° quad error (with differential driver)

Characteristic	Discrete I/O specifications
Field side power dissipation (worst case at 32V DC)	3.6 W for inputs 4.0 W for outputs
Input section(12 pt)	
Function	Monitors on/off states from up to 12 DC voltage inputs
Logic side power requirements (typical)	7 mA per energized input @+5V
Input signals (exceed IEC standards)	Nominal 24 VDC on, 0 VDC off
UH Max (max. allowed voltage)	30 VDC
IH Max (max. current @ 30 VDC)	7.5 mA
UL Min	Polarity independent
Guaranteed on	14 VDC
IH Min (min. current @ UH Min)	2.8 mA
Guaranteed off	5 VDC
IT Min (current allowed when off)	.75 mA
Time delay on	1 ms max.
Time delay off	1 ms max.
Protection of logic circuits	Optical isolation between the logic and field sides 4000 V peak
Input groups	Two groups of IEC Type 1 inputs per NEMA Standard, ICS 3-1983, Table 3-304-2. UL 508 spacing
Output section (6 pt sink)	
Function	Sinks an external DC source to six loads
Logic side power requirements (typical)	25 mA per energized output @+5V
DC source requirements	Nominal 24V DC; range 5 to 32 VDC
Protection of logic circuits	Optical isolation between the logic and field side

Grouping of outputs	One group of 6 solid-state switches. UL 508 spacing
Fuse per group of 6 switches	Fast-acting, UL rated 3A 250 VAC metric fuse, 5 x 20 mm
Maximum current per group	2 A of continuous current for the group; each switch is rated at .4 A continuous
Switch characteristics	Solid-state switches
Time delay on for resistive loads	30 μ sec max
Time delay off for resistive loads	300 μ sec max
Leakage current in off state	0.5 mA max
Switch voltage, maximum ON	1.8 VDC @ .4 A
Surge current, maximum	2.5 A for 40 msec., every 2 seconds
Response to scan loss	All outputs are reset to the OFF state

Software Setup

The PiC9 is programmed using PiC(Servo)Pro software. There are several tasks you must perform in the three areas covered below (Servo Setup, Hardware Declarations, and Software Declarations) when you start programming in PiC(Servo)Pro.

Servo Setup

Follow the steps below when setting up your servo information.

1. With PiC(Servo)Pro running, select Servosetup and tuning (**S**) from the Programs menu.
2. Open a new or existing file from the File (**F**) menu.
3. Press **<Insert>** to insert an axis.
4. Enter all or any of the following that you are using for servo control from the PiC9.

Enter in Define Axis Box	Description
Encoder Input 1 Input Slot 3 Channel 1	Encoder channel 1 is the encoder feedback coming directly from the drive. It is connected internally.
Analog Output 1 Output Slot 3 Channel 1	Analog Output Channel 1 is connected internally to the velocity command (VCS+ and VCS-) of the drive.
Encoder Input 2 Input Slot 3 Channel 2	Encoder Channel 2 is available on the 40-pin screw terminal connector in the I/O section of the PiC9. See FIGURE 1-5. I/O Screw Terminal Connector on page 12.
Analog Output 2 Output Slot 3 Channel 2	Analog Output Channel 2 is available on the 40-pin screw terminal connector in the I/O section of the PiC9. See FIGURE 1-5. I/O Screw Terminal Connector on page 12.

Hardware Declarations

Follow the steps below to declare the hardware for the PiC9.

1. With PiCPro running, select **Declarations (D)**, **Hardware (H)**.
2. This brings up the **Master Rack Hardware Declarations** table. With the cursor on Slot 2, press **<F8>** to select the correct CPU.
3. If PiC9 is available as a choice, select **PiC9**. Press **<Enter>**.
The **Math Coprocessor (NPX) present on CPU?** box appears. Select **No** or **Yes**. Press **<Enter>**.
Note: By selecting **PiC9**, the correct modules are automatically entered in slots 3 and 4. Proceed to Step 12 if you are using an expansion rack. If no expansion rack is used, press **<F10>** to accept your hardware declarations.
If PiC9 is not available as a choice, select **PiC90**. Press **<Enter>**. Go through the remaining steps.
4. Select **Turbo**. Press **<Enter>**.
5. Answer **Yes** or **No** depending on whether or not you have the optional math coprocessor installed in the PiC9. Press **<Enter>**.
6. Move the cursor to Slot 3. The Servo Encoder/Analog Output Module must be declared in Slot 3. To do this, press **<F8>**.
7. Select **Mixed Module**. Press **<Enter>**.
8. Select **Servo Encoder (3AO 2EI)**. Press **<Enter>**.
9. Move the cursor to Slot 4. The 24VDC 16 Input/8 Sink Output module must be declared in Slot 4. To do this, press **<F8>**.
10. Select **Mixed Module**. Press **<Enter>**.
11. Select **In/Out 24V DC (16 In 8 Out Sink)**. Press **<Enter>**.
12. If you are using the optional expansion feature, then declare the first expansion module in Slot 5 and the second expansion module in Slot 6.
13. Press **<F10>** to accept your hardware declarations.

Software Declarations

There are some I/O points that must be declared in the software declarations table. These are listed below.

1. With PiCPro running, select Declarations (**D**), Software (**S**).
2. This brings up the **Software Declarations** table. Enter the following I/O points.

I/O Point	Description
04.7	Output 7 controls the Drive Enable. When it is on, the drive is enabled.
04.8	For future use, Output 8 will select the 3-pin port for serial communication when it is on.
I4.16	Input 16 indicates that the drive is Ready when it is on.
I4.17	On when output fuse is blown. 24V DC Power must be connected to DCCOM1 and DCL1 of the DC output section as shown in Figure 1-15 for this to work properly.

NOTES

Component Installation Procedures

Appendix A is divided into six sections. The sections correspond to the six areas shown in Figure A-1 of the PiC9 module on which components can be installed or replaced. They include the following:

3. System EPROM
4. Ladder Memory
5. Math Coprocessor (Optional)
6. Battery
7. Flash Memory System Disk (FMSDISK) (Optional)
8. Fuse

Preliminary Steps

Before adding/replacing any PiC9 component, follow standard precautions for handling any electronic components.

1. Disconnect power to the drive.
2. Remove all cables.
3. Remove the PiC9 from the cabinet.
4. Lay the unit on a static-free surface, PiC9 module side up. Ground yourself using a properly grounded wrist strap before you open the module.
5. Remove the two screws (one on the top, one on the bottom) which secure the center front panel covering the drive J connectors.
6. Remove the cover by loosening four screws (two on the top, two on the bottom) and sliding the cover off.

CAUTION
Do not touch the pins on any of the ICs. IC circuitry can be easily damaged. Broken or bent pins prevent the IC from functioning properly.

Refer to Figure A-1 for the correct location and/or orientation of any component you are installing or replacing on the PiC9. Turn to the section for the component you are adding/replacing and follow any steps listed there. When the component is added/replaced, proceed with the following final steps to return the PiC9 system to operation.

Final Steps

After adding/replacing any PiC9 component, do the following:

1. Replace the PiC9 cover by sliding it back in place and screwing in the four screws.
2. Replace the center front panel with the two screws.
3. Install the PiC9 into the cabinet.
4. Connect all the cables.
5. Place the scan rocker switch in the Stop position.
6. Turn on power at the main disconnect switch and the drive.
7. Check the applicable LEDs.
8. Using PiCPro, download the application module (see PiCPro Software Manual).
9. Turn rocker switch to Run.

CAUTION

Follow the power on sequence as defined above. If not followed, the PiC9 may malfunction.

A-1. Component Location on PiC9 Board

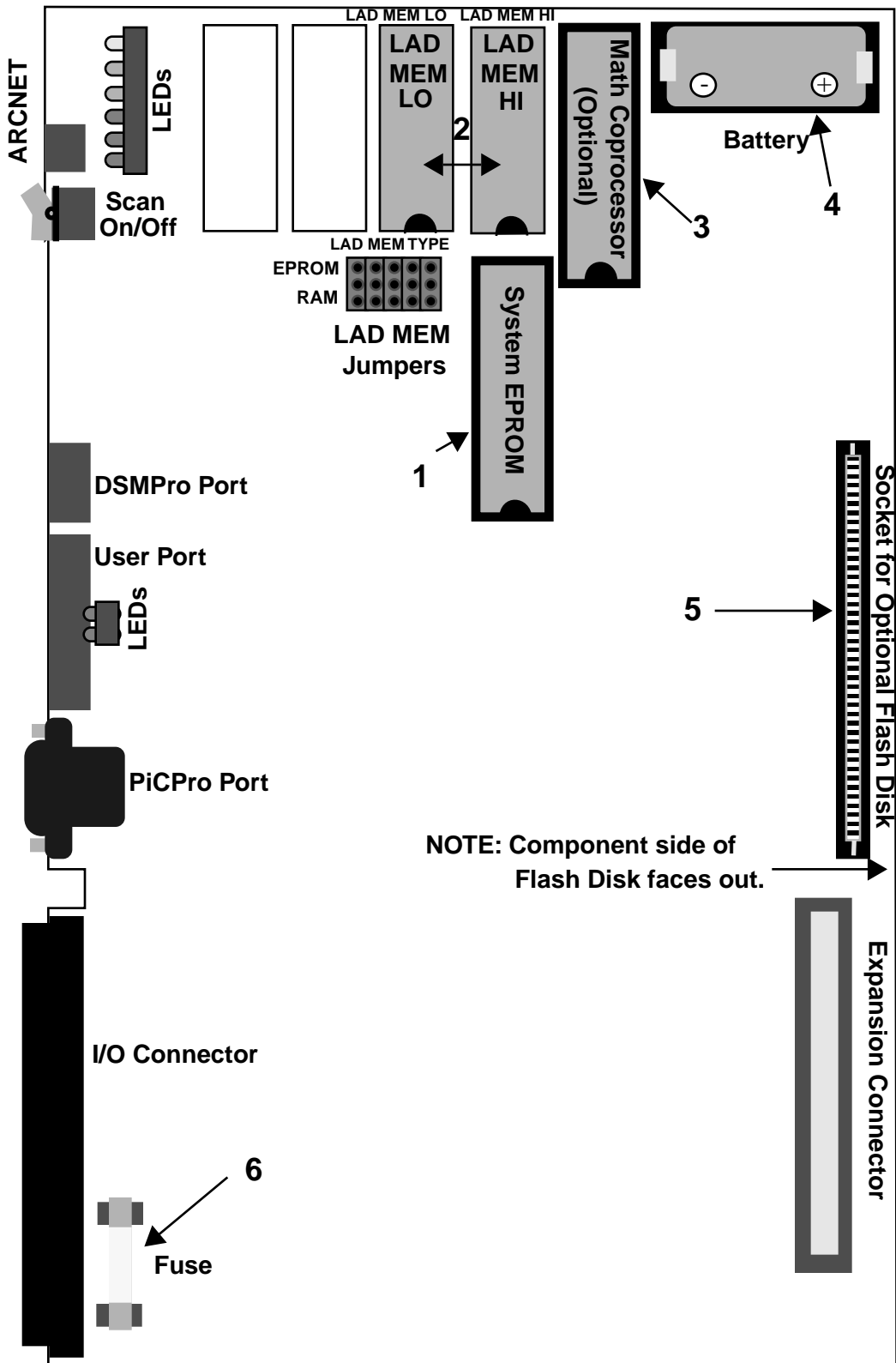

Section 2. System EPROM

Whenever a new version of the PiCPro Software is released, you will receive a new system EPROM with instructions on how to install it. The system EPROM is in location 1 of Figure A-1 on page A-3.

Section 3. Ladder Memory

An application may be programmed into a pair of user-supplied EPROMs, and then the EPROMs may be inserted in the PiC9 module at location 2 in Figure A-1 on page A-3. Recommended EPROMs include:

Advanced Micro Devices (AMD) AM27C010-120DC (128K x 8)

The PiCPro Software Manual gives directions for creating a file in a format suitable for an EPROM. Such a file may be loaded from a workstation into the EPROMs using any of a number of commercially available EPROM Programmers.

Follow the preliminary steps found on page A-1 and then proceed with the following steps to install.

1. Use Figure A-1 to see where the EPROMs should be placed. If a pair of EPROMs occupies the sockets already, use an EPROM-removal tool to remove them.
2. To insert a new pair of EPROMs, start with the one labeled LAD MEM LO. Use an insertion tool to position it over the left socket labeled LAD MEM LO with the notched end of the EPROM matching the notched end of the socket.
3. Line up the pins and push it in place. Repeat with the LAD MEM HI socket of the pair.

CAUTION

Check that the EPROM is going in the correct socket. The processor cannot access an EPROM in the wrong place.

Make sure the EPROM is oriented correctly. If it is installed backwards, it may be destroyed when power is turned on to the system.

4. Place the LAD MEM TYPE jumper in the EPROM position. (See Figure A-1 for jumper location.)

Follow the final steps found on page A-2 when you are finished.

Section 4. Optional Math Coprocessor

Some applications may require a math coprocessor installed on the PiC9 module. The socket for this IC is at location 3 in Figure A-1 on page A-3.

Follow the preliminary steps found on page A-1 and then proceed with the following.

The math coprocessor is shipped in a socket for easy installation. The math coprocessor, the socket, and the PiC9 module socket are each notched. All notches should be on the same end.

IMPORTANT

Be sure to check that the math coprocessor is oriented correctly with all notches on the same end. Press the math coprocessor firmly in place.

If the math coprocessor is installed backwards, it may be damaged or destroyed when power is turned on to the system.

Follow the final steps found on page A-2 when you are finished.

Section 5. Replacing the battery on the PiC9

The battery is found at location 4 in Figure A-1 on page A-3. Follow the procedure below to replace a battery.

After AC power has been applied to the PiC9 for at least five minutes, follow the preliminary steps found on page A-1. Then proceed as follows.

1. Use Figure A-1 to locate the battery. Note how it is oriented.
2. Use an insulated screwdriver to pry the old battery up at one end, then lift it out.
3. Replace it with a 3V, 2/3A lithium battery. See the specification sheet in Chapter 1.

Follow the final steps found on page A-2 when you are finished.

Section 6. Optional Flash Memory System (FMDSISK)

The optional Flash Memory System (FMS) board provides flash disk storage for things like ladder source files on the PiC9. Files are sent to the FMS board via PiCPro software.

A-2. FMDSISK Board

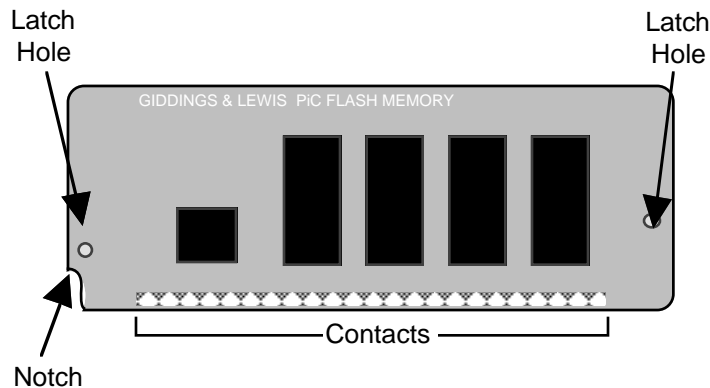

The FMS board is available in either a 4 Megabyte (4M) or 8 Megabyte (8M) size.

FMDSISK	Part Number
4M FMDSISK	502-03882-00
8M FMDSISK	502-03882-20

The FMDSISK board socket is in location 5 in Figure A-1. Follow the preliminary steps found on page A-1 and then proceed with one of the following depending on the type of socket on the PiC9.

With the socket on the left, the FMS board must be slid straight into the channels on the ends. With the socket on the right, the FMS board must be angled into the socket and then rotated up to latch in.

Straight-in Socket

(Top View)



1. To insert the FMS board in this socket, grasp it by the sides. The component side of the board faces the outside edge of the PiC9 module ensuring that the notched end will go into the correct channel of the FMS socket. Avoid touching the contacts at the bottom of the FMS board.
2. Line up the sides of the FMS board with the channels on the ends of the socket being sure the notched end of the FMS board is going into the notched end channel of the socket.
3. Press the FMS board firmly in place. Be sure the latches on the FMS socket go into the latch holes on the FMS board.

Angle-in Socket

(Top View)



1. To insert the FMS board in this socket, grasp it on the sides or the top. The component side of the board faces the outside edge of the PiC9 module. Avoid touching the contacts at the bottom of the FMS board.
2. Insert the FMS board at an angle applying a firm but gentle pressure. Forcing the board could damage it. Push the board downward into the socket, ensuring that the board is fully and properly inserted.
3. Rotate the board gently upward until the latches snap it into place. Be sure the latches on the FMS socket go into the latch holes on the FMS board.

Follow the final steps found on page 2 when you are finished.

Section 7. Replacing a Blown Fuse

The PiC9 has one fuse for the group of six outputs. Use a meter to check the condition of the fuse or see the Software Manual for how to monitor the condition of the fuse from within PiCPro software.

The fuse is in series with the HOT line to the group in order to protect the output switching device and the load. The fuse protects against a short circuit in an output device, but not against a sustained marginal overload current.

The fuse is at location 6 in Figure A-1 on page A-3. To change a blown fuse, follow the preliminary steps found on page A-1 and then proceed as follows.

1. Use an insulated screwdriver or fuse puller to remove the fuse.
2. Put a new fuse in its slot. The replacement must be a fast-acting 3A 250 VAC fuse. The following are recommended:

Littlefuse 235-003 or Bussman GMA-3 (or an equivalent)

3. Check the wiring to the devices to find out why the fuse blew, and correct the situation before you continue running the program.

Follow the final steps found on page A-2 when you are finished.

Communications Connections

It is possible to establish communication between PiC9s and/or any PiCs equipped with peer-to-peer communication capability using various connection configurations. These configurations will depend on how many PiCs you are communicating with and how great a distance the total network will cover.

Two to eight PiCs can be connected using twisted pair wire. The twisted pair wiring can consist of one or more lengths connecting the PiCs. A **minimum** length of 6 feet (2 m) between devices on a network is required. The total network length end-to-end may be a **maximum** of 400 feet (122 m). This is referred to as a *wire segment*.

CAUTION

The network is polarity dependent. Always connect the positive (+) of the twisted pair interface of the first PiC to the positive (+) of the twisted pair interface of the second PiC and the negative (-) to the negative (-) etc.

With the use of active hubs, it is possible to link up to 255 PiCs in a network extending up to four miles (6400 m) using twisted pair, coax and/or fiber optics cabling. With coax cable, a minimum length of 6 feet (2 m) between devices on a network is required. The total network length end-to-end may be a maximum of 2000 feet (610 m). With glass fiber optics, there is no minimum length. The total network length end-to-end may be a maximum of 3000 feet (915 m), 6000 feet (1800m), or 9000 feet (2740m) based on 50, 62.5, or 100 micron glass fiber optics cable respectively.

CAUTION

Although considerable noise immunity is obtained with the isolated twisted pair interface, care should be taken to route twisted pair wires and coax cables separate from wires used for high voltage, motors, solenoids, etc.

Communication Topologies

There are several possible layouts or topologies for peer-to-peer communications. They are summarized here.

The PiC or any device that contains an ARCNET controller chip and cable transceiver and is connected to a network is referred to as a *node*. The PiC has no internal termination and, therefore, whenever a PiC appears at the end of a segment it must be terminated with a 100 Ω resistor.

A device that facilitates interconnecting multiple nodes by matching line impedance is called a *hub*. The active hubs used here have internal termination.

Bus Topology

In bus topology, the nodes can be connected without the use of a hub. Cabling distances and node numbers are less than when a hub is used. Whenever a bus topology is used, each end of the bus must be terminated with a resistive terminator.

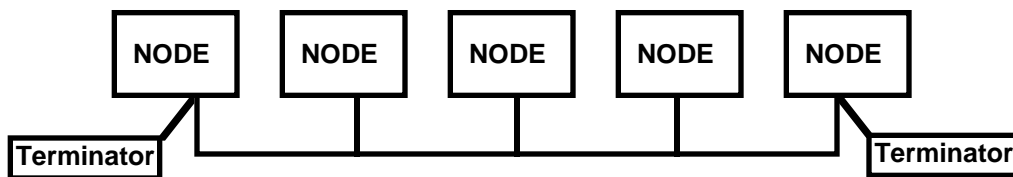

Star Topology

The star topology requires the use of a hub. This topology makes troubleshooting easier since only one node is connected to one port on the hub.

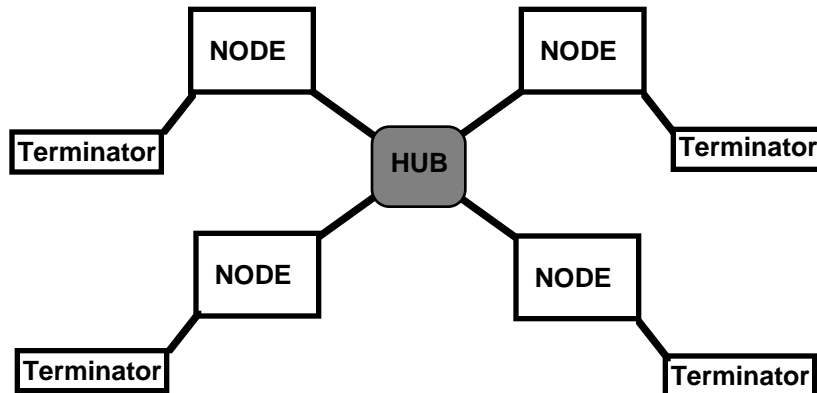

Distributed Star Topology

Whenever hubs are cascaded together, the topology is called a distributed star. Each hub can have various nodes connected to it.

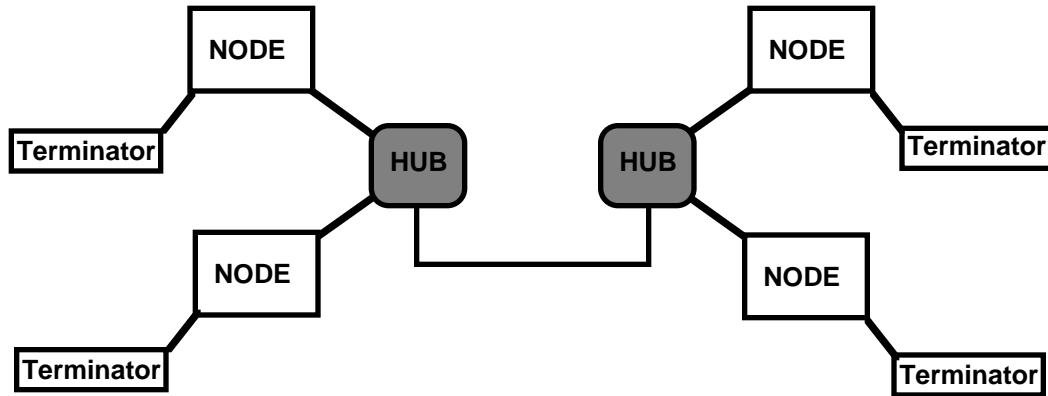

Distributed Star/Bus Topology

A star topology can be combined with a bus topology.

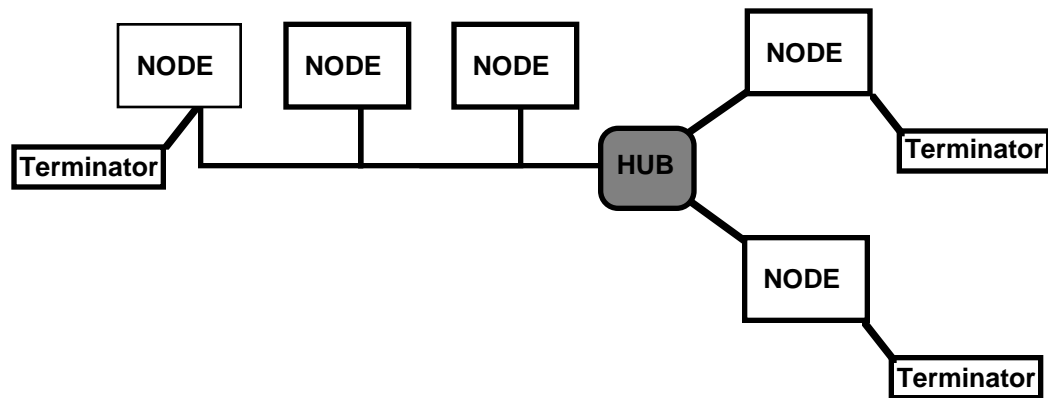

Connecting 2 to 8 PiCs up to 400 feet - Bus Topology

Connections for peer-to-peer expansion using two different types of PiCs are illustrated in Figure B-1. Twisted pair wire is used. Shielded twisted pair wire is shown below and is required for EMC compliance. 100 Ω resistors must be installed at each end of the wire segment.

B-1. Connections between PiCs - Bus Topology

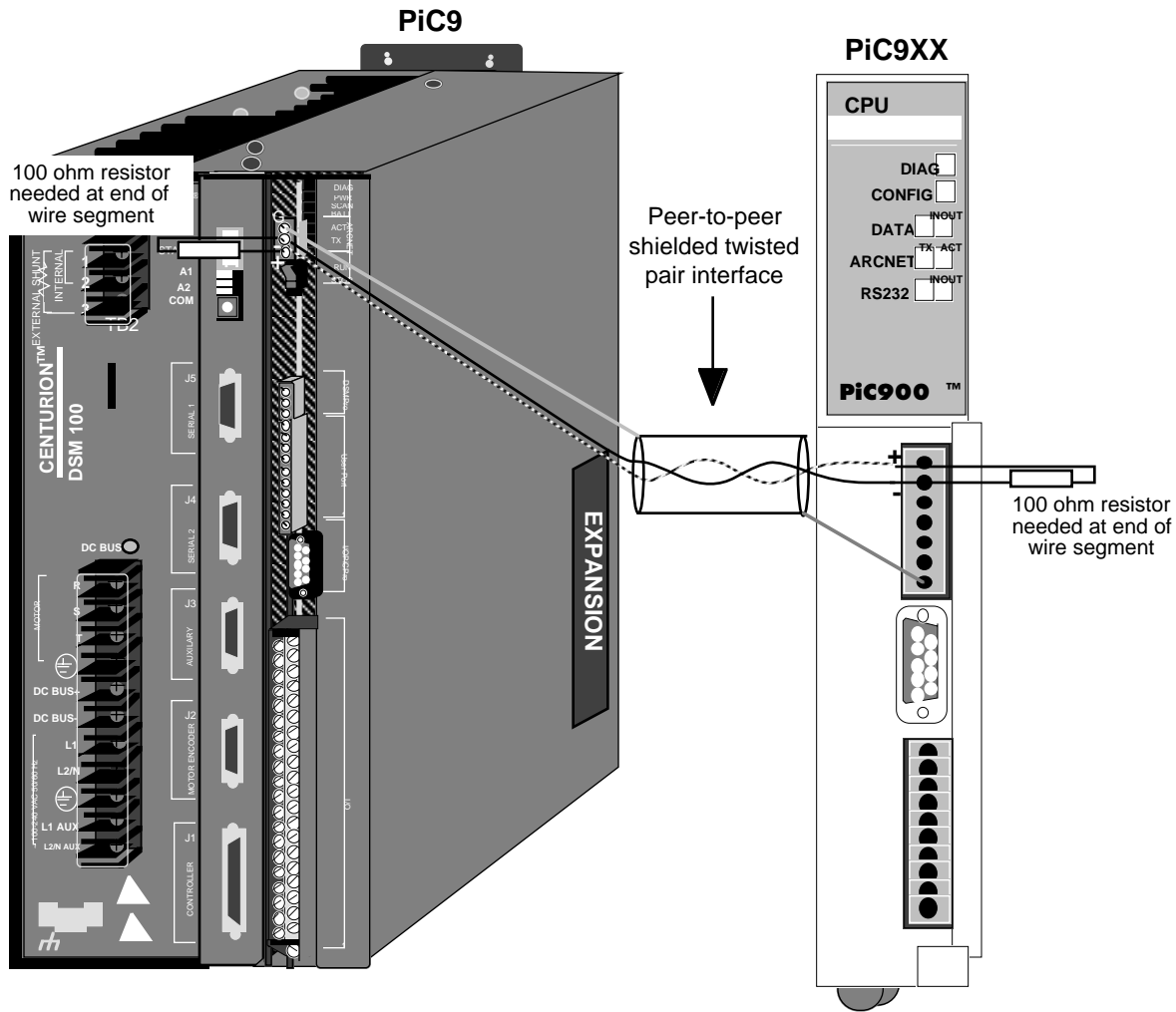
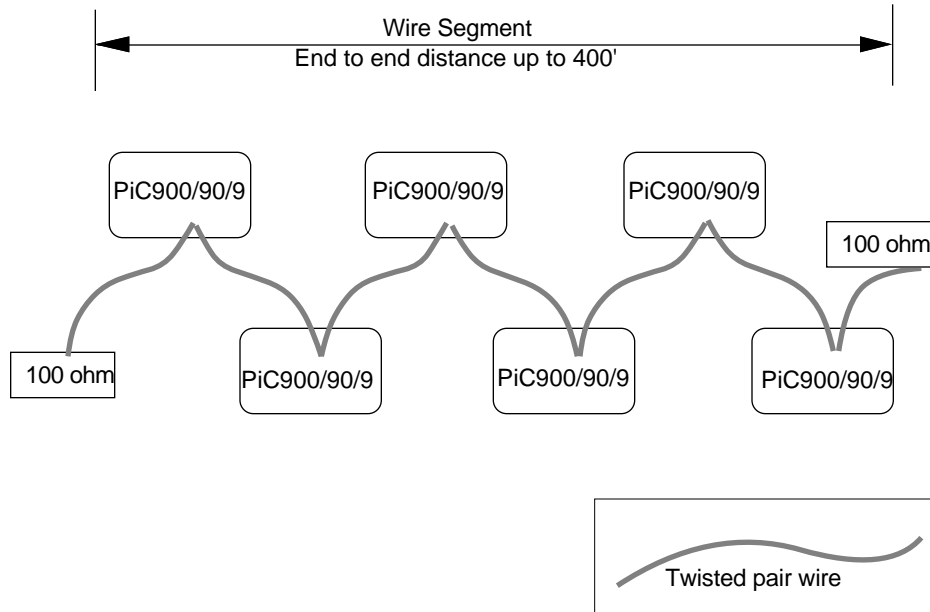

Figure B-2 illustrates how multiple PiCs can be connected using twisted pair wire. The total twisted pair wire segment is under 400 feet (122 m). Notice that the ends of the wire segment must be terminated with a 100 Ω resistor.

B-2. Connecting PiCs within 400 feet (122 m) - Bus Topology



Expanding with Active Hubs

An active hub may be added to the system if greater than 400 feet distances need to be covered and/or if more than eight PiCs need to be included in the network. An active hub also allows you to communicate using a variety of cabling types.

The MOD HUB from Contemporary Control Systems, Inc. (CCSI) is an electronic device used to expand networks. Its main function is to match line impedance. It regenerates the network signal for distances from 6 to 400 feet (100 m) using twisted pair cable, from 6 to 2,000 feet (610 m) using RG 62/U coax cable in a bus topology (0 to 2000 in a star topology), or 0 to 9,000 feet (2740 m) using glass fiber optics cable. With the use of a MOD HUB, these cabling types can be inter-mixed depending upon the requirements of your network.

The MOD HUB uses plug-in expansion modules each containing four ports. The ports may be all one type of connection (twisted pair, coax, or fiber optics) or a mix of two types of connections (twisted pair/coax, twisted pair/fiber optics, coax/fiber optics). You decide on the type of cabling or mix of cabling you need and choose the appropriate expansion modules. The MOD HUB is available in two sizes: a 16 port enclosure holding up to four modules or a 48 port enclosure holding up to 12 modules. The MOD HUB requires AC power and is available in 120V or 240V versions.

Diagnostic LEDs help with troubleshooting. Each expansion module has LEDs indicating activity for each port. There are four other LEDs on the timing module of the hub. Refer to the MOD HUB documentation from CCSI for more information.

B-3. MOD HUB 16 with Four Expansion Modules

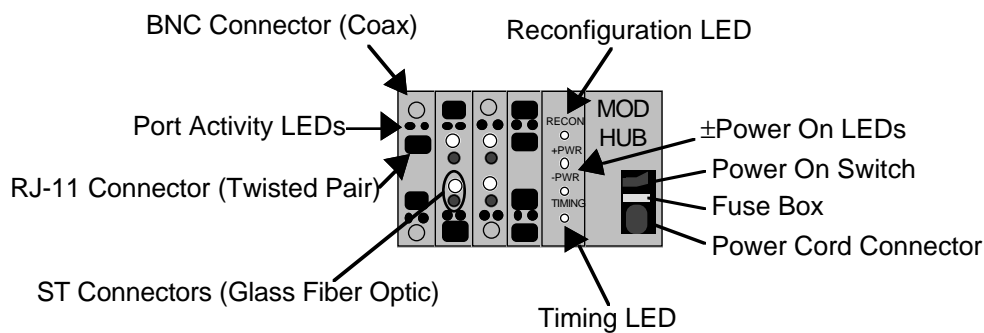

There is also a network interface module (NIM) available from CCSI if you need to interface your network to a PC. The PCX series of NIMs supports coax, twisted pair, or fiber optics connectors on it. See Figure B-8.

Connectors

Coax

Coax cable is connected to the MOD HUB using BNC tee connectors.

B-4. BNC Connector for Coax Cable

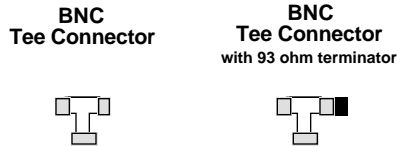

Twisted Pair

The twisted pair wire from the PiCs must be connected to an RJ11 modular plug. The pinout for the RJ11 modular plug for any of the recommended CCSI products is shown in Figure B-5. Be sure that you match polarity when making the connection from the connector on the PiC to the RJ11 modular plug.

B-5. RJ11 Modular Plug (6 position - 4 contact) for Twisted Pair Wire

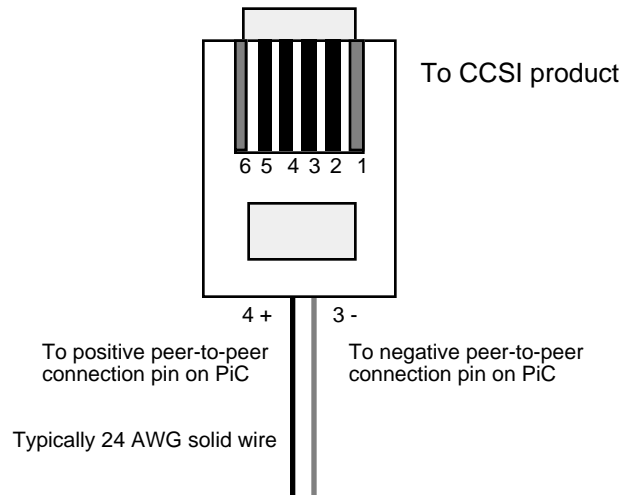

Refer to the specification table at the end of for alternate wire sizes.

Fiber Optics

Fiber optic cables are duplex, multimode in either 50/125, 62.5/125, or 100/140 micron cable. Use the bayonet style ST connectors.

B-6. ST Connector for Fiber Optic Cable

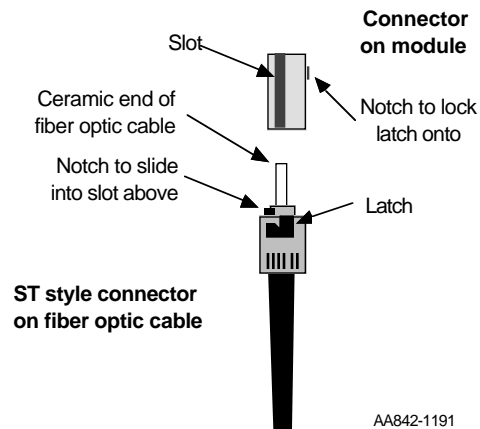

CAUTION

Never create a loop with the network cabling. For example, do not connect the PiCs (or hubs) in such a manner that the cabling attached to the last device is also connected to the first device.

Figures B-7 and B-8 illustrate some of the connection configurations for peer-to-peer communication using active hubs.

In Figure B-7, two active hubs are connected using coax cable. The twisted pair wire is used to connect a bus of PiCs to the hubs. Note that the end of the bus is terminated with a 100 Ω resistor.

B-7. MOD HUBS using Coax and Twisted Pair - Distributed Star/Bus Topology

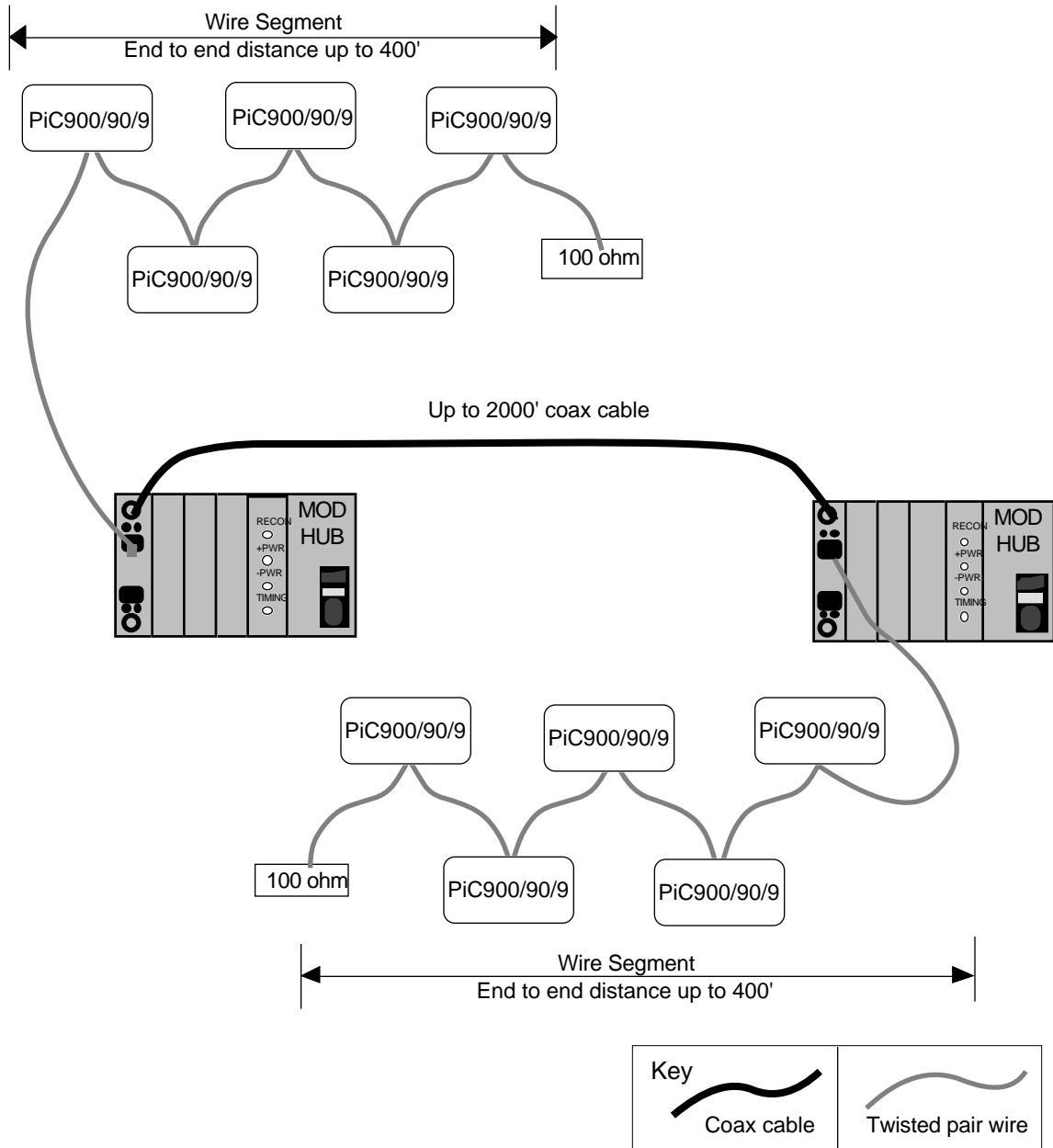
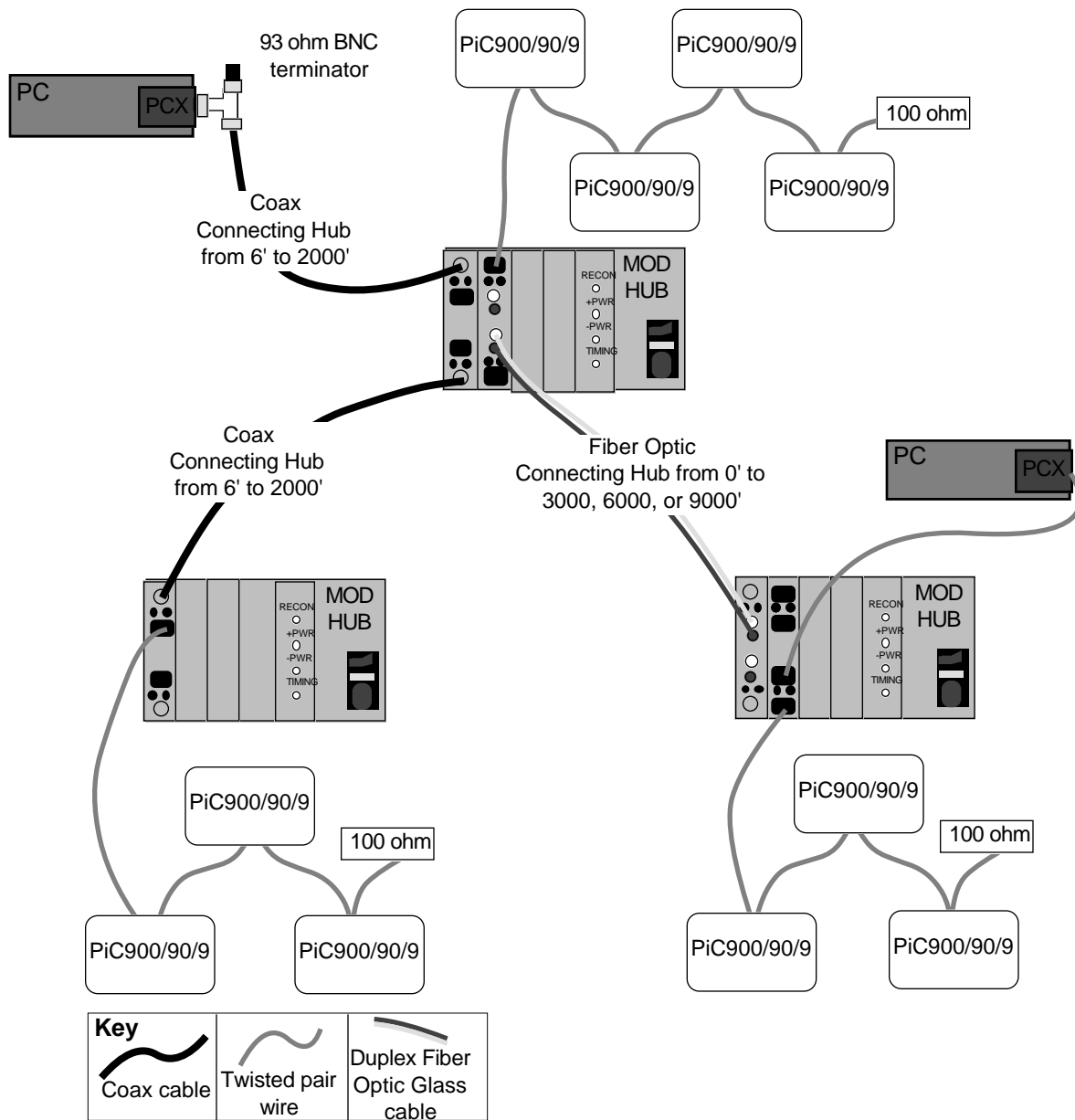

Figure B-8 shows some other network possibilities. The maximum cable distance between any two PiC900s located at opposite ends of the network is 20,000 feet/4 miles (6400 m). More modules could be added to each MOD HUB as your system requires.

B-8. Cascading hubs to further extend the network - Distributed Star/Bus Topology



Some of the items listed below are available from:

Contemporary Control Systems, Inc. (CCSI)
 2512 Wisconsin Avenue
 Downers Grove, IL 60515

It is recommended that they be used for peer-to-peer communications.

NOTE: Part numbers may be changed by manufacturers.

CCSI also has network configuration guides available and other information you may find helpful.

Recommended connectivity products	Description
Active MOD HUB	MOD HUB-16 (16 port, 120V) MOD HUB-16E (16 port, 240V) MOD HUB-16F (16 port, 120 V, flange mount) MOD HUB-16 EF (16 port, 240 V, flange mount) MOD HUB-48 (48 port, 120 V) MOD HUB-48E (48 port, 240 V) NOTE: There is also a HUB rack mounting kit available.
EXP modules	The following expansion plug-in modules are available, each with four ports: EXP-TPS (Twisted Pair) EXP-CXS (Coax) EXP-TPS/CXS (Twisted Pair/Coax) EXP-FOG-ST (Glass Fiber Optics with ST connector) EXP-TPS/FOG-ST (Twisted Pair/Glass Fiber Optics with ST connector) EXP-CXS/FOG-ST (Coax/Glass Fiber Optics with ST connector)
PCX module	An ARCNET Network Interface Module for the IBM compatible PC PCX-CXS (Coax) PCX-TPS (Twisted Pair) PCX-FOG-ST (Glass Fiber Optics with ST connector)
ARC DETECT™	Handheld network analyzer recommended for maintaining and troubleshooting your network.
BNC Tee connector	BNC/T
93 Ω BNC terminator	BNC/TER
RG62/U coax cable	Belden #86262
Glass fiber optics	
50/125	Belden 227822
62.5/125	Belden 225872
100/140	Belden 226822

Twisted pair wire	<p>24 or 26 AWG solid or 26 AWG stranded One recommended type is Belden 1227A - 24 AWG solid copper unshielded twisted pair. This comes with two pairs. Use only one pair.</p> <p>For EMC compliance, it is necessary to use shielded twisted pair wire. One recommended type is Belden 9729-24 AWG (7 x 32) stranded conductors. This comes with two pairs. Use only one pair and terminate the shield wire only if there is a pin provided for this at the ARCNET node.</p> <p style="text-align: center;">IMPORTANT</p> <p>Use of other wire sizes may result in an impedance mismatch that could disable communications with some or all nodes on a network when doing peer-to-peer communications.</p>
-------------------	--

EMC Guidelines

Background on EMC (Electromagnetic Compatibility) Compliance

In order to market products in the European Union after January 1, 1996, an electromagnetic compatibility directive (EU Directive 89/336/ECC) must be met. All products must be designed and manufactured in such a way that:

1. Electromagnetic disturbances generated by the products do not cause interference to other systems.
2. The performance of the product is not affected by electromagnetic disturbances within the environment in which the product is intended to operate.

The directive refers to relevant harmonized European EMC standards against which product conformity can be assessed, although other methods of assessment, notably the preparation of a Technical File, are permissible. The equipment manufacturer or the manufacturer's agent in the Community must make a Declaration of Conformity and can place the CE mark on the product. Failure to conform with the requirements of the directive can result in a total ban on sales throughout the Single Market and legal action could be taken against the signatory of a false declaration of conformity.

RFI Emission and Immunity

The EMC product characteristics are classified by the emission and immunity performance.

Emissions not only include radiated noise from the product enclosure and cabling, but also that which is conducted away from the product along the cables connected to it. This may be subsequently radiated from the cable or conducted directly into another product which shares this cable e.g. the main AC supply.

Immunity is how susceptible a product is (e.g. to the radiated and conducted emissions from the product mounted next to it). To ensure compatibility, the immunity of a product must always exceed the expected emissions in the environment in which it operates as is shown in the diagram below. This is to ensure a margin of safety.

C-1. Safety Margin

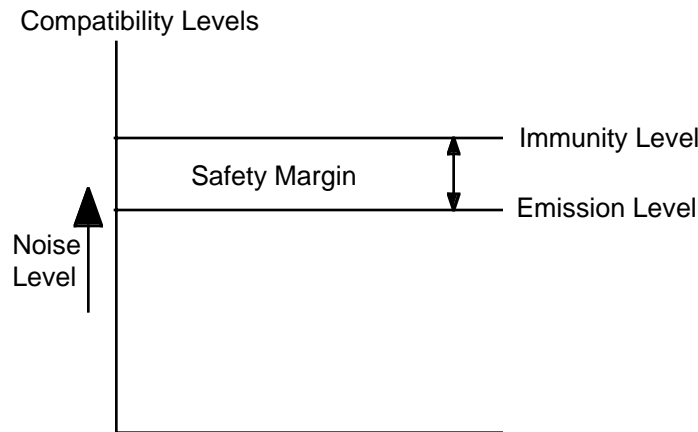

In addition to conducted and radiated immunity, products must also be capable of withstanding:

1. Electro-static discharges (ESD)
2. Conducted fast transient voltages

The discharge spark generated from ESD can easily damage electronic components.

The conducted fast transient voltages are induced in cables laid in close proximity to other cables in which large inductive loads are switched (such as relays, contactors, and AC motor starters). This is a good example of what can happen to sensitive control and signal cabling connected to drives when poorly installed in enclosures on industrial sites.

Classes of EMC Operating Environments

Before the correct level of EMC can be designed into equipment, the EMC operating environment must be defined. For example in industrial locations where high power equipment is in use, high levels of background electrical noise would be expected when compared to a household or office environment. Since it is more expensive to reduce the emissions from higher power equipment than to increase the immunity, the emission limits allowed in industrial environments are higher than for household or office environments. Vice versa for immunity because of the higher emission limits in industrial environments, the immunity requirements are more strict than for the household or office environment. Hence in order to achieve EMC between different equipment, it is essential to know what EMC operating environment it is to be installed in, and to compare the installation environment to the environment for which it was designed.

Today using generic EMC standards, two environments are defined:

1. Industrial
2. Residential, commercial, and light industrial

The environments are locations defined on the basis of whether the AC supply is shared with other locations or is buffered from them with a distribution transformer. If your location is buffered via a distribution transformer, then you are in an industrial environment. If you share your AC supply with a neighboring location, then you are in a residential, commercial, or light industrial environment. For example, an industrial unit which shares its AC supply with a neighboring unit is defined as a residential, commercial, and light industrial location. If it is supplied from its own distribution transformer, then it is an industrial location.

Conformance with the EMC Directive

Giddings & Lewis will be complying to the Directive by self-certification to the following generic EMC standards:

1. EN50081-2 for industrial emissions using EN55011 (based upon CISPR 11A)
2. EN50082-2 for industrial immunity using
 - IEC 1000-4-2 (ESD)
 - IEC 1000-4-3 (Radiated susceptibility)
 - IEC 1000-4-4 (Electrical fast transient)

A statement of compliance will be made with the letters “EMC” on the product, but will be valid only if the product is installed properly.

Changes to the PiC Products

Giddings & Lewis PiC products had originally been designed with a high level of noise immunity and tested according to standards such as NEMA showering arc and the original version of IEC 801-2. However, the EU directive for immunity requires testing to standards that have more variables and are more repeatable. The directive also requires control of emissions, something that is not regulated in U. S. industrial environments.

As a result, changes have been made to the hardware modules within the PiC product line. The changes have included the addition of filtering, re-routing of foils and/or the addition of ground planes to printed circuit boards, use of some conductive enclosures, provision for shielded wires for peer-to-peer communication, and internal connection of SPG to field side connectors.

Changes Affecting the User

Many of the changes Giddings & Lewis has implemented are transparent to the user. However, there are some changes affecting user installation.

Giddings & Lewis continues to recommend separation of low level signals (encoder, analog, communications, fast DC inputs) from higher voltage or current lines from any of the above. More specifically, maintain *at least* one inch of separation around encoder signals and around communication signals.

It is no longer necessary to connect a wire from a module to SPG. This user-installed wire had been a source of emissions and thus the connection should not be made. Analog modules typically had this requirement in the past.

To prevent excessive conducted emissions from a DC power source (typically 24V) used for digital I/O, a 1000 picofarad capacitor should be used. Connect the capacitor from the +24V DC to COMMON at the distribution terminals. The same applies to any other external DC power source used with the PiC product.

The figure on the left below illustrates the connection method *before* EMC compliant products were available. The figure on the right illustrates the recommended connections when using EMC compliant products. On the right, note that the SPG connection has been eliminated and that a capacitor is connected to the 24V DC supply.

C-2. EMC Compliance Connections

Connections before EMC Compliant Products Recommended EMC Compliant Connections

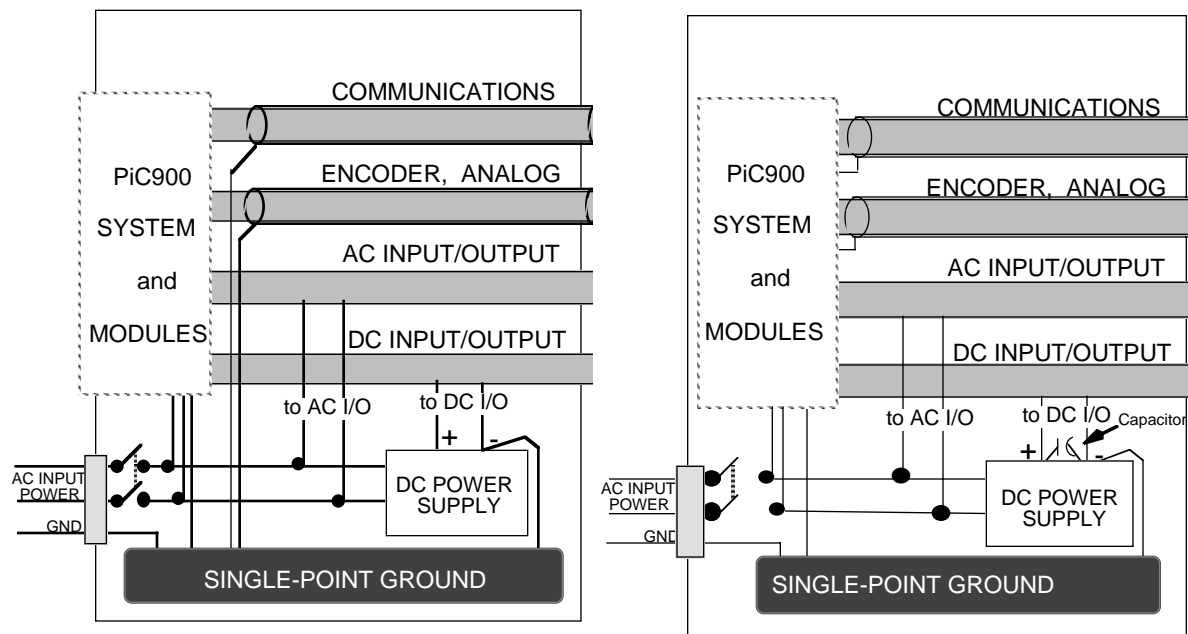

There is now a provision for shield termination to the CPU modules and the PiC9 for peer-to-peer communication. Shielded cable must be used to reduce emissions.

Inside a control cabinet, the practice of connecting the shields of shielded cables at the modules should be continued. For shielded cable entering/leaving the cabinet, see the diagram below.

C-3. Connecting Shielded Cable

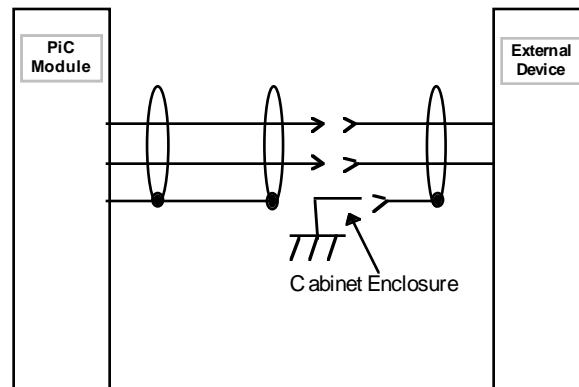

The two different methods of terminating shields are used to accommodate two different immunity requirements. Immunity required inside an enclosure is considered lower because cables are typically less than 3 meters in length and/or can be separated from each other and from noise sources.

Immunity required external to an enclosure is considered higher because the user may have less control over the noise environment. Low level signal cables that can be external to an enclosure and AC/DC digital I/O cables have been tested at a 2 KV level for electrical fast transients (EFTs). Low level signals that can be less than 3 meters in length or can be separated from noise sources are tested at a 1 KV level.

Under the stated conditions, there will be no disturbance of digital I/O, encoder, or stepper operation. For analog signals, there may be momentary disturbances but there will be self-recovery when the noise subsides.

In order to meet the EU directive requirement for emissions and immunity, fiber optics must be used for I/O expansion.

Although the PiCs will pass the electrical fast transient test on incoming power lines, users may still want to use a power line conditioner as detailed in Chapter 1 of the Hardware Manual.

As a general precaution, do not operate transmitters, arc welding equipment, or other high noise radiators within one meter of a PiC enclosure that has the door open. Continue to equip inductive devices, if they are in series with a mechanical contact or switch, with arc suppression circuits. These devices include contactors, solenoids and motors. Shield all cables that carry heavy current near the system, using continuous foil wrap or conduit grounded at both ends. Such cables include

EMC Guidelines

power leads for high-frequency welders and for pulse-width-modulated motor drives.

Worst case tests with analog I/O modules have caused momentary disturbances no greater than .5V in a +10V to -10V range and .5 mA in a 4 to 20 mA range. Worst case tests with an RTD module have caused momentary disturbances no greater than + or -4°C in a range of -200° to 266°C. Worst case tests with a JK thermocouple module have caused momentary disturbances no greater than + or - 1 mV over a 100 to 1.

Index

A

- active hub B-6
- analog output
 - channel 1 1-35
 - channel 2 1-35
 - connections 1-14
 - specifications 1-32
 - theory of operation 1-15
- application
 - EPROMs
 - recommended A-4
- ARC DETECT B-11
- ARCNET 1-1, B-2
 - connections B-4
 - connector 1-10
 - LEDs 1-10

B

- battery
 - BATT LED 1-10
 - installation A-1, A-5
 - type 1-30, A-5
- blown fuse 1-37
- BNC connector B-7, B-11
- bus topology B-2, B-4, B-5

C

- Centurion DS100
 - drive 1-1, 1-3
- clock
 - time-of-day 1-4
- coax
 - cable B-1, B-6
 - connector B-7
- communications
 - connections B-1
 - peer-to-peer (ARCNET) 1-30, B-1
 - serial 1-37
- connections
 - analog output 1-14
 - ARCNET B-1, B-4
 - drive 1-3

EMC C-4

- encoder 1-17
- internal
 - analog output channel 1 1-9
 - drive enable 1-9
 - encoder channel 1 1-9
 - serial communications 1-9
 - system status 1-9

connector

- 10-pin user port 1-9
- 2-pin ARCNET 1-9
- 40-pin I/O 1-9
- 9-pin D PiCPro 1-9
- BNC B-11
- coax B-7
- fiber optic B-8
- twisted pair B-7

D

- declarations
 - hardware 1-36
- diode 1-28
- directive
 - EMC C-1
- distributed star topology B-3
- distributed star/bus topology B-3, B-9, B-10
- drive
 - Centurion DS100 1-3
 - enable 1-37
 - status 1-37

E

- electrical noise 1-13
- electromagnetic compatibility C-1
- electro-static discharge C-2
- EMC C-1
 - conformance C-3
 - directive C-1
 - operating environments C-2
 - PiC products C-3
- EMC compliance
 - recommended wire B-12

EMC connections C-4

encoder

- channel 1 1-35
- channel 2 1-35
- connections 1-17
- drivers 1-16
- input 1-16
- specifications 1-32
- theory of operation 1-20

EPROM

- installation A-4
- programmer A-4
- recommended application A-4

ESD C-2

expansion 1-2

expansion rack

- adding 1-2
- connecting 1-6

F

fast input 1-21

fast transient voltage C-2

fiber optic B-1, B-6, B-8

- cable B-6
- connector B-8

Flash Memory System Disk (FMDSISK)

- installation A-1, A-6

FMDSISK

- installation A-6
- part numbers A-6
- size A-6
- socket A-6

fuse

- blown 1-37, A-8
- circuitry 1-26
- installation A-1, A-8
- type 1-34, A-8

H

hardware declarations 1-36

I

I/O

- connections 1-13
- port 1-11
- pinout 1-12
- screw terminal connections 1-12
- specifications 1-33

incremental encoders 1-19

- pulse 1-19
- quadrature 1-19

inductive load 1-27

input

- 24 VDC 1-22
- connections 1-22
- specifications 1-33
- theory of operation 1-23

installation

- battery A-1, A-5
- EPROM A-4
- FMDSISK A-1, A-6
- fuse A-1, A-8
- ladder memory A-1, A-4
- math coprocessor A-1, A-5
- system EPROM A-1

installation system EPROM A-4

L

ladder memory

- installation A-1, A-4

leakage current 1-25

LEDs

- ARCNET 1-10
- battery 1-10
- diagnostic 1-10, B-6
- power 1-10
- scan 1-10
- status 1-10

M

main disconnect switch 1-4

math coprocessor

- installation A-1, A-5
- part number 1-30

mod hub B-6

module

- network interface B-6
- PCX B-11

N

network

- interface module B-6

- length B-1
- polarity B-1
- noise
 - electrical 1-13
 - immunity B-1

O

- output
 - 24 VDC 1-26
 - connections 1-26
 - protection from inductive loads 1-27
 - specifications 1-33
 - theory of operation 1-27

P

- PCX module B-11
- peer-to-peer
 - connections B-1
- peer-to-peer (ARCNET)
 - communications 1-30, B-1
- PiC9 1-1
 - connectors 1-9
 - expansion 1-2
 - LEDs 1-9
 - models 1-29
 - mounting instructions 1-6
 - part numbers 1-29
 - specifications 1-29
 - speed 1-29
- PiCPro
 - port 1-11, 1-30
 - software 1-1
 - FMS files A-6
 - new release A-4
 - setup 1-35
- polarity
 - network B-1
- ports
 - I/O 1-11
 - PiCPro 1-11
 - user 1-11
- position transducer 1-19
- power supply
 - internal 1-3
- proximity switch 1-25

R

- resistor B-4
- RFI
 - emission C-1
 - immunity C-1
- RJ11 modular plug B-7
- rocker switch 1-4, 1-10
- run/stop switch 1-4, 1-10

S

- scan control
 - run/stop switch 1-4
- scan switch 1-10
- serial communication 1-37
- socket
 - FMSDISK A-6
- software
 - setup 1-35
- specifications
 - analog output 1-32
 - encoder 1-32
 - I/O 1-33
 - input 1-33
 - output 1-33
 - PiC9 1-29
- ST connector B-8
- star topology B-2
- startup
 - overview 1-5
- switch
 - main disconnect 1-4
 - proximity 1-25
 - run/stop 1-4, 1-10
 - scan 1-10
- system EPROM A-4
 - installation A-1, A-4

T

- time-of-day clock
 - tolerance 1-30
- topology
 - bus B-2, B-4, B-5
 - communication B-2
 - distributed star B-3
 - distributed star/bus B-3, B-9, B-10
 - star B-2

twisted pair

connector B-7

size B-12

wire 1-30, B-1, B-6, B-7, B-12

U

up/down counter

24-bit 1-21

user port

LEDs 1-11

pinout 1-11

V

voltage

fast transient C-2

W

wire segment B-1