

MMC[®] Smart Drive[™] and Digital MMC Control Hardware Manual



Version 6.2
Catalog No. M.1301.5524
Part No. M.3000.1430



**IND. CONT. EQ.
12KP**

Keep all product manuals as a product component during the life span of the product.
Pass all product manuals to future users/owners of the product.

KOLLMORGEN[®]

Because Motion Matters[™]

Record of Revisions

Edition	Valid for	Description
03/2007	PiCPro V16.1	Major Update
10/2007	PiCPro V16.1 SP2	Added MMC-D8
05/2008	PiCPro V16.1 SP3	Added 4 analog drives, various manual updates
09/2008	PiCPro V17.0	Added S200-DLS Drives
12/2008	PiCPro V17.0	Rev 1 fixed various typos
01/2009	PiCPro V17.0	Rev 2 added CE/UL info to S200-DLS
03/2009	PiCPro V17.0	Rev 3 added Aux Feedback Connector to S200DLS
02/2010	PiCPro V18.0	Kollmorgen Branding & S200 BiSS
03/2011	PiCPro V18.0 SP1	Added 230V, 3-Phase Drives
01/05/12	PiCPro V18.0 SP2	Added 460V, 3-Phase NextGen Drives
08/15/12	PiCPro V18.0 SP3	Added SFD on 460V SDN Drives Added Enhanced Feedback drives to the 230V and 460V Smart Drives
02-15-13	PiCPro V18.0 SP4	Added 230V SDN Drives

Third party brands and trademarks are the property of their respective owners

Technical changes to improve the performance of the equipment may be made without notice!

Printed in USA

All rights reserved. No part of this work may be reproduced in any form (by printing, photocopying, microfilm or any other method) or processed, copied or distributed by electronic means without the written permission of Kollmorgen.

NOTE

These products are being manufactured and sold by G & L Motion Control, Inc., a Kollmorgen company.

Progress is an on-going commitment at Kollmorgen. We continually strive to offer the most advanced products in the industry; therefore, information in this document is subject to change without notice. The text and illustrations are not binding in detail. Kollmorgen shall not be liable for any technical or editorial omissions occurring in this document, nor for any consequential or incidental damages resulting from the use of this document.

Kollmorgen makes every attempt to ensure accuracy and reliability of the specifications in this publication. Specifications are subject to change without notice. Kollmorgen provides this information "AS IS" and disclaims all warranties, express or implied, including, but not limited to, implied warranties of merchantability and fitness for a particular purpose. It is the responsibility of the product user to determine the suitability of this product for a specific application.

DO NOT ATTEMPT to use any Kollmorgen product until the use of such product is completely understood. It is the responsibility of the user to make certain proper operation practices are understood. Kollmorgen products should be used only by qualified personnel and for the express purpose for which said products were designed.

Should information not covered in this document be required, contact the Customer Service Department, Kollmorgen, 672 South Military Road, P.O. Box 1960, Fond du Lac, WI 54936-1960. Kollmorgen can be reached by telephone at (920) 921-7100 or (800) 558-4808 in the United States or by e-mail at glmotion.support@kollmorgen.com.

Catalog No. (Order No.) M.1301.5524

Printed Version Part No. M.3000.1430

Electronic Version Part No. M.3000.1429

Release 02152013

©2013, Kollmorgen

Table of Contents

Table of Contents	3
1 Introduction to the MMC Smart Drive	9
1.1 Overview.....	9
1.2 Contents of This Manual.....	9
1.3 Software and Manuals.....	9
1.3.1 Required Software and Manuals.....	9
1.3.2 Suggested Manuals.....	9
1.4 Kollmorgen Support Contact.....	11
2 Safety Precautions	13
2.1 System Safety.....	13
2.1.1 User Responsibility.....	13
2.1.2 Safety Instructions.....	13
2.2 Safety Signs.....	14
2.3 Warning Labels.....	14
2.4 Safety First.....	15
2.5 Safety Inspection.....	15
2.5.1 Before Starting System.....	15
2.6 After Shutdown.....	15
2.7 Operating Safely.....	16
2.8 Electrical Service & Maintenance Safety.....	16
2.9 Safe Cleaning Practices.....	17
3 Installing the MMC Smart Drive	19
3.1 Storing the Drive Before Installation.....	19
3.2 Unpacking the Drive.....	19
3.3 Handling an MMC Smart Drive.....	19
3.4 Inspecting the Drive Before Installation.....	19
3.5 Complying with European Directives.....	20
3.6 Conforming with UL and cUL Standards.....	20
3.7 General Installation and Ventilation Requirements.....	20
3.8 Controlling Heat Within the System.....	21
3.9 Bonding.....	22
3.9.1 Bonding a Subpanel Using a Stud.....	22
3.9.2 Bonding a Ground Bus Using a Stud.....	22
3.9.3 Bonding a Ground Bus or Chassis Using a Bolt.....	22
3.9.4 Grounding Multiple Drive Cabinets.....	23
3.9.5 Bonding Multiple Subpanels.....	23
3.10 Drive Mounting Guidelines.....	23
3.11 Drive System Grounding Procedures.....	24
3.11.2 Grounding Multiple Drives in the Same Cabinet.....	27
3.12 System Wiring Guidelines.....	27
3.12.1 Recommended Signal Separation.....	28
3.12.2 Building Your Own Cables.....	30
3.12.3 Routing Cables.....	30
3.13 Wiring the Drive.....	30
3.13.1 Sizing the 24V Power Supply.....	30
3.13.2 System AC Power Wiring Guidelines.....	31
3.13.3 Connecting Interface Cables.....	32
3.13.4 Preparing Motor Connection Wires.....	33

4 System Power Devices	37
4.1 AC Input Power Requirements.....	37
4.2 Protection	40
4.2.1 Motor Overload Protection.....	40
4.2.2 Motor Thermal Protection	40
4.2.3 S200-DLS Drive Protection Requirements	41
4.2.4 230V Smart Drive Protection Requirements.....	43
4.2.5 460V Smart Drive Protection Requirements.....	45
4.3 Line Reactors.....	50
4.3.1 Specifications and Dimensions for Required Line Reactors.....	51
4.4 Isolation Transformers	57
4.5 External Shunts.....	58
4.5.1 Choosing External Shunts	58
4.5.2 Mounting External Shunts	61
4.5.3 Connecting Shunt Modules	66
4.5.3.1 230V, 1-Phase MMC Smart Drive Shunt Wiring	66
4.5.3.2 460V, 3-Phase MMC Smart Drive (-SD) Shunt Wiring.....	68
4.6 Line Filters.....	69
4.6.1 Line Filters and CE Compliance	69
4.6.2 Dimensions for 230V Line Filters.....	74
4.6.3 Dimensions for 460V Line Filters.....	75
5 230V 3 Phase MMC Smart Drive NextGen	77
5.1 Control Section Connectors, Switches, LEDs	80
5.1.1 Status Display.....	80
5.1.2 Node Address Rotary Switches.....	80
5.1.3 Digital Link Ports.....	81
5.1.4 Feedback Connectors (F1 & F2)	83
5.1.4.1 Feedback Connectors (F1 and F2) Details	88
5.1.4.2 Feedback Port (F1/F2) to Motor Cables.....	93
5.1.5 Drive I/O Connectors (IO1 & IO2).....	98
5.2 Power Section Connectors.....	102
5.2.1 DC Power Connector.....	102
5.2.1.1 "EN" requirements and Safe-off Operation	102
5.2.2 AC Power Connector	103
5.2.2.1 Line Fusing.....	103
5.2.3 Motor/Brake Connector	104
5.2.3.1 Motor/Brake Cables	106
5.2.3.2 Motor Chokes.....	106
5.2.4 DC Bus/Regen Connector	107
5.2.4.1 Bus/Regen Connections	107
5.2.4.2 External Regen Resistors	108
5.3 Specifications - 230V MMC Smart Drive NextGen.....	109
5.3.1 General Data	109
5.3.2 Physical and Electrical Data	114
5.4 Dimensions	115
6 460V 3 Phase MMC Smart Drive NextGen	119
6.1 Control Section Connectors, Switches, LEDs	122
6.1.1 Status Display.....	122
6.1.2 Node Address Rotary Switches.....	122
6.1.3 Digital Link Ports.....	123
6.1.4 Feedback Connectors (F1 & F2)	125
6.1.4.1 Feedback Connectors (F1 and F2) Details	130

6.1.4.2 Feedback Port (F1/F2) to Motor Cables	135
6.1.5 Drive I/O Connectors (IO1 & IO2)	140
6.2 Power Section Connectors	144
6.2.1 DC Power Connector	144
6.2.1.1 "EN" requirements and Safe-off Operation	144
6.2.2 AC Power Connector	145
6.2.2.1 Line Fusing	145
6.2.3 Motor/Brake Connector	146
6.2.3.1 Motor/Brake Cables	148
6.2.3.2 Motor Chokes	148
6.2.4 DC Bus/Regen Connector	149
6.2.4.1 Bus/Regen Connections	149
6.2.4.2 External Regen Resistors	149
6.3 Specifications - 460V MMC Smart Drive NextGen	151
6.3.1 General Data	151
6.3.2 Physical and Electrical Data	156
6.4 Dimensions	157
7 230V 1/3 Phase MMC Smart Drive	161
7.1 Control Section Connectors, Switches, LEDs	164
7.1.1 LEDs	164
7.1.2 PiCPro Port (Digital Interfaced Drives)	164
7.1.3 PiCPro Port (Analog Drives)	166
7.1.4 Node Address Rotary Switch (Digital Interfaced MMC-SD Only)	169
7.1.5 Digital Link Ports (Digital Interfaced MMC-SD Only)	170
7.1.6 Feedback Connectors (F1 & F2)	172
7.1.6.1 Feedback Connectors (F1 and F2) Details	177
7.1.6.2 Feedback Port (F1/F2) to Motor Cables	182
7.1.7 Drive I/O Connector (IO)	194
7.2 Power Section Connectors	201
7.2.1 24 VDC IN/Brake Connector	202
7.2.1.1 "EN" requirements and Safe-off Operation	203
7.2.2 Power Connector	204
7.2.3 DC Bus/Regen Connector (3-phase drive only)	207
7.3 Specifications - 230V MMC Smart Drive	208
7.3.1 General Data for all 230V Models	208
7.3.2 Physical and Electrical Data for 230V Drives	211
7.4 Dimensions for 230V MMC Smart Drive	213
8 460V 3-Phase MMC Smart Drive	219
8.1 Control Section Connectors, Switches, LEDs	219
8.2 Power Section Connectors	220
8.2.1 Size 1 Power Section Connectors	220
8.2.1.1 Shunt/DC Bus Connector	222
8.2.1.2 AC Power Connector	223
8.2.1.3 Motor Connector	223
8.2.1.4 24V Power Connector (J1)	224
8.2.1.5 Motor Brake Connector (X101)	225
8.2.2 Size 2 Power Section Connectors	225
8.2.2.1 AC Power Connector	227
8.2.2.2 Motor Connector	228
8.2.2.3 24V Power Connector (J1)	229
8.2.3 Size 3 Power Section Connectors	230
8.2.3.1 AC Power Connector	232

8.2.3.2 Motor Connector	233
8.2.3.3 24V Power Connector (J1).....	234
8.2.3.4 Motor Brake Connector (X101)	235
8.2.4 Size 4 Power Section Connectors	235
8.2.4.1 AC Power Connector	237
8.2.4.2 Motor Connector	238
8.2.4.3 24V Power Connector (J1).....	239
8.2.4.4 Motor Brake Connector (X101)	240
8.2.4.5 Fan Connector (X36).....	241
8.3 Typical 460V Drive Connection Layout.....	242
8.4 Specifications - 460V MMC Smart Drive).....	243
8.4.1 Common Data for Size 1, 2, 3, 4, 5 (All Models)	243
8.4.2 Physical/Electrical Data for 460V Size 1 Smart Drives.....	246
8.4.3 Physical/Electrical Data for 460V Size 2 Smart Drives.....	248
8.4.4 Physical/Electrical Data for 460V Size 3 Smart Drives.....	251
8.4.5 Physical/Electrical Data for 460V Size 4 Smart Drives.....	254
8.5 Dimensions for the 460V Smart Drives	257
9 S200-DLS Drive.....	265
9.1 S200-DLS Option Card	267
9.1.1 LED Indicators	267
9.1.2 Diagnostic Indicator Details	267
9.1.3 Digital Link LEDs	267
9.1.4 Node Address Rotary Switches.....	268
9.1.5 Digital Link Ports.....	269
9.1.6 Auxiliary Feedback Port.....	271
9.1.7 Drive I/O and I/O Power Ports	279
9.1.8 Drive I/O Port Details.....	281
9.1.8.1 Drive I/O Port Outputs.....	282
9.1.8.2 Drive I/O Port Inputs.....	282
9.1.8.3 Drive I/O Port Wiring Example	282
9.2 Power Section Wiring Accessories	283
9.3 Specifications - S200-DLS Drive.....	285
10 Motor Cables & Connectors	287
10.1 Flex Cable Installation Guidelines.....	287
10.1.1 Bending Radius	287
10.1.2 Cable Tension	288
10.2 Flex Cable Installation.....	288
10.3 AKM/DDR Motor Power Cables.....	290
10.4 LSM/MSM Motor Connector Kits	291
10.5 LSM/MSM Motor Power Cables.....	292
10.6 LSM/MSM Motor Fan Cables.....	295
11 Maintenance and Troubleshooting.....	297
11.1 Maintenance	297
11.2 Troubleshooting	298
11.2.1 General Troubleshooting	298
11.2.2 Power LED	298
11.2.3 Power-On Diagnostics.....	298
11.2.4 Run-Time Diagnostics	298
11.2.4.1 Troubleshooting with the Diagnostic LED (D1)	299
11.2.4.2 Troubleshooting with the 7-Segment Display.....	299
11.2.4.3 Troubleshooting using the Status LED (STATUS)	307

12 Resolver Interface Option Module	311
12.1 Theory of Operation.....	311
12.2 Installing the Resolver Module	311
13 Drive Resident Digital MMC Control	315
13.1 Introduction	315
13.1.1 Overview	315
13.1.2 Major Components.....	315
13.2 Installing the Drive Resident Digital MMC Control.....	317
13.2.1 Installing into a 230V MMC-SD Drive.....	317
13.2.2 Installing into a 460V MMC-SD Drive.....	317
13.3 System Wiring Guidelines	318
13.4 Starting an Operation	319
13.4.1 Connecting the Drive Resident Digital MMC Control to the Application.....	319
13.4.2 Basic Setup and Maintenance Procedures	319
13.4.3 Start-up Diagnostics.....	320
13.4.3.1 Power LED	320
13.4.3.2 Scan LED	320
13.4.3.3 Drive Resident Digital MMC Control Start-Up Diagnostic LEDs	321
13.4.4 MMC Run-Time Diagnostics	322
13.5 Connectors & Operation	323
13.5.1 PiCPro Port (P1)	323
13.5.2 Block I/O Port (C1).....	323
13.5.3 User Port.....	327
13.5.4 Ethernet Port.....	333
13.5.5 General I/O Port (C5).....	335
13.5.5.1 DC Output Operation.....	340
13.5.5.2 DC Input Operation.....	342
13.6 Specifications	344
14 Declarations of Conformity	347
A 460V MMC Smart Drive DC Bus Sharing	353
A.1 Introduction	353
A.2 DC Bus Sharing with AC Power to All Drives.....	353
A.3 DC Bus Sharing with AC Power to One Drive.....	355
Index	359
Sales and Service	365

1 Introduction to the MMC Smart Drive

1.1 Overview

This manual covers four distinct products:

- The Analog and Digital Interfaced 230V MMC Smart Drive (MMC-SD). The 230V Smart Drive is detailed exclusively in [Chapter 7 on page 161](#)
- The Digital 460V Smart Drive NextGen. The 460V Smart Drive NextGen is detailed exclusively in [Chapter 6 on page 119](#)
- The Analog and Digital Interfaced 460V MMC Smart Drive (MMC-SD). The 460V Smart Drive is detailed exclusively in [Chapter 8 on page 219](#)
- The S200-DLS Digital Link Drive which receives motion commands via a digital connection (Digital Link)

1.2 Contents of This Manual

This manual includes the following major topics:

- Information to safely operate and maintain the equipment in a safe manner.
- User responsibilities for product acceptance and storage.
- Power and environmental information for general power, control cabinet, grounding, heat control and handling.
- Procedures for mounting, wiring, and connecting the MMC Smart Drive and standard Kollmorgen motors recommended for use with the MMC Smart Drive.
- Recommended drive system wiring guidelines for signal separation and differential devices. Methods to ensure ElectroMagnetic Compatibility.
- The location of connectors on the drive and descriptions of their functionality including I/O, encoder, serial interface and motor/brake connector locations and signal descriptions.
- Physical, electrical, environmental and functional specifications/dimensions.
- Description of the minimal maintenance necessary.
- A troubleshooting chart of potential problems and possible solutions.
- Part numbers and descriptions for the drive and related equipment.

1.3 Software and Manuals

1.3.1 Required Software and Manuals

PiCPro (one of the following)

- Professional Edition
- MMC Limited Edition
- Monitor Edition

1.3.2 Suggested Manuals

- Function/Function Block Reference Guide
- Motion Application Specific Function Block Manual

- Ethernet Application Specific Function Block Manual
- General Purpose Application Specific Function Block Manual

1.4 Kollmorgen Support Contact

Contact your local Kollmorgen representative for:

- Sales and order support
- Product technical training
- Warranty support
- Support service agreements

Kollmorgen Technical Support can be reached:

- In the United States, telephone (800) 558-4808
- Outside the United States, telephone (920) 921-7100
- E-mail address: glmotion.support@kollmorgen.com
- Web site: www.kollmorgen.com

2 Safety Precautions

READ AND UNDERSTAND THIS SECTION IN ITS ENTIRETY BEFORE UNDERTAKING INSTALLATION OR ADJUSTMENT OF THE MMC SMART DRIVE AND ANY ASSOCIATED SYSTEMS OR EQUIPMENT

The instructions contained in this section will help users to operate and maintain the equipment in a safe manner.

PLEASE REMEMBER THAT SAFETY IS EVERYONE'S RESPONSIBILITY

2.1 System Safety

The basic rules of safety set forth in this section are intended as a guide for the safe operation of equipment. This general safety information, along with explicit service, maintenance and operational materials, make up the complete instruction set. All personnel who operate, service or are involved with this equipment in any way should become totally familiar with this information prior to operating.

2.1.1 User Responsibility

It is the responsibility of the user to ensure that the procedures set forth here are followed and, should any major deviation or change in use from the original specifications be required, appropriate procedures should be established for the continued safe operation of the system. It is strongly recommended that you contact your OEM to ensure that the system can be safely converted for its new use and continue to operate in a safe manner.

2.1.2 Safety Instructions

- Do not operate your equipment with safety devices bypassed or covers removed.
- Only qualified personnel should operate the equipment.
- Never perform service or maintenance while automatic control sequences are in operation.
- To avoid shock or serious injury, only qualified personnel should perform maintenance on the system.

ATTENTION	
	Do not touch the main power supply fuses or any components internal to the power modules while the main power supply switch is ON. Note that when the main power switch is OFF, the incoming supply cable may be live.

- **GROUNDING (Protective Earth)**

The equipment must be grounded (connected to the protective earth connection) according to OEM recommendations and to the latest local regulations for electrical safety. The grounding (protective earth) conductor must not be interrupted inside or outside the equipment enclosures. The wire used for equipment grounding (connection to protective earth) should be green with a yellow stripe.

2.2 Safety Signs

The purpose of a system of safety signs is to draw attention to objects and situations which could affect personal or plant safety. It should be noted that the use of safety signs does not replace the need for appropriate accident prevention measures. Always read and follow the instructions based upon the level of hazard or potential danger.

2.3 Warning Labels

Hazard warning

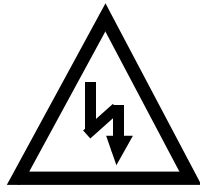

Danger Electric
Shock Risk

When you see this safety sign on a system, it gives a warning of a hazard or possibility of a hazard existing. The type of warning is given by the pictorial representation on the sign plus text if used.

To ignore such a caution could lead to severe injury or death arising from an unsafe practice.

Danger, Warning, or Caution warning

Symbol plus DANGER, WARNING or CAUTION:
These notices provide information intended to prevent potential personal injury and equipment damage.

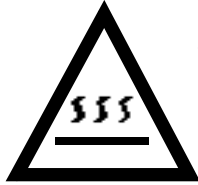
Hot Surface warning

Symbol plus HOT SURFACE:
These notices provide information intended to prevent potential personal injury.

2.4 Safety First

Kollmorgen equipment is designed and manufactured with consideration and care to generally accepted safety standards. However, the proper and safe performance of the equipment depends upon the use of sound and prudent operating, maintenance and servicing procedures by trained personnel under adequate supervision.

For your protection, and the protection of others, learn and always follow these safety rules. Observe warnings on machines and act accordingly. Form safe working habits by reading the rules and abiding by them. Keep these safety rules handy and review them from time to time to refresh your understanding of them.

2.5 Safety Inspection**2.5.1 Before Starting System**

- Ensure that all guards and safety devices are installed and operative and all doors which carry warning labels are closed and locked.
- Ensure that all personnel are clear of those areas indicated as potentially hazardous.
- Remove (from the operating zone) any materials, tools or other objects that could cause injury to personnel or damage the system.
- Make sure that the control system is in an operational condition.
- Make certain that all indicating lights, horns, pressure gauges or other safety devices or indicators are in working order.

2.6 After Shutdown

Make certain all controlled equipment in the plant is safe and the associated electrical, pneumatic or hydraulic power is turned off. It is permissible for the control equipment contained in enclosures to remain energized provided this does not conflict with the safety instructions found in this section.

2.7 Operating Safely

- Do not operate the control system until you read and understand the operating instructions and become thoroughly familiar with the system and the controls.
- Never operate the control system while a safety device or guard is removed or disconnected
- Where access to the control system is permitted for manual operation, only those doors which provide that access should be unlocked. They should be locked immediately after the particular operation is completed.
- Never remove warnings that are displayed on the equipment. Torn or worn labels should be replaced.
- Do not start the control system until all personnel in the area have been warned.
- Never sit or stand on anything that might cause you to fall onto the control equipment or its peripheral equipment.
- Horseplay around the control system and its associated equipment is dangerous and should be prohibited.

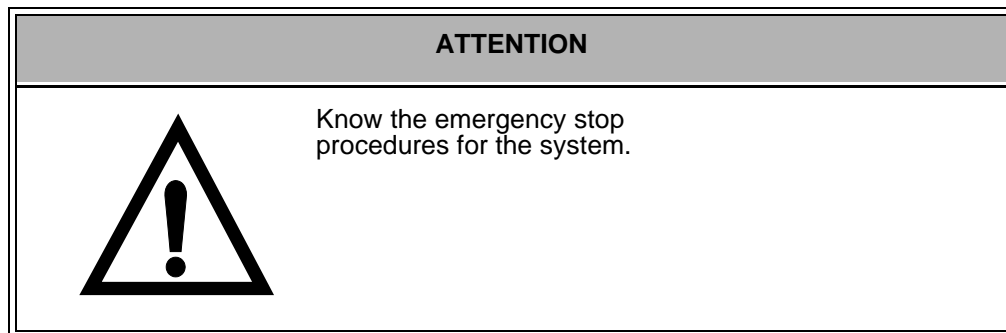

- Never operate the equipment outside specification limits.
- Keep alert and observe indicator lights, system messages and warnings that are displayed on the system.
- Do not operate faulty or damaged equipment. Make certain proper service and maintenance procedures have been performed.

2.8 Electrical Service & Maintenance Safety

- **ALL ELECTRICAL OR ELECTRONIC MAINTENANCE AND SERVICE SHOULD BE PERFORMED BY TRAINED AND AUTHORIZED PERSONNEL ONLY.**
- It should be assumed at all times that the POWER is ON and all conditions treated as live. This practice assures a cautious approach which may prevent accident or injury.
- To remove power:
LOCK THE SUPPLY CIRCUIT DISCONNECTING MEANS IN THE OPEN POSITION.
APPLY LOCKOUT/TAGOUT DEVICES IN ACCORDANCE WITH A DOCUMENTED AND ESTABLISHED POLICY.

- Make sure the circuit is safe by using the proper test equipment. Check test equipment regularly.

ATTENTION	
	Care should be taken if you are manually discharging the bus capacitors.

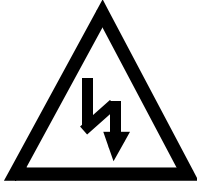
WARNING	
	Even after power to the drive is removed, it may take up to 10 minutes for bus capacitors to discharge to a level below 50 VDC. To be sure the capacitors are discharged, measure the voltage across the + and - terminals for the DC bus.

- There may be circumstances where troubleshooting on live equipment is required. Under such conditions, special precautions must be taken:
 - Make sure your tools and body are clear of the areas of equipment which may be live.
 - Extra safety measures should be taken in damp areas.
 - Be alert and avoid any outside distractions.
 - Make certain another qualified person is in attendance.
- Before applying power to any equipment, make certain that all personnel are clear of associated equipment.
- Control panel doors should be unlocked only when checking out electrical equipment or wiring. On completion, close and lock panel doors.
- All covers on junction panels should be fastened closed before leaving any job.
- Never operate any controls while others are performing maintenance on the system.
- Do not bypass a safety device.
- Always use the proper tool for the job.
- Replace the main supply fuses only when electrical power is OFF (locked out).

2.9 Safe Cleaning Practices

- Do not use toxic or flammable solvents to clean control system hardware.
- Turn off electrical power (lock out) before cleaning control system assemblies.
- Keep electrical panel covers closed and power off when cleaning an enclosure.

- Always clean up spills around the equipment immediately after they occur.
- Never attempt to clean a control system while it is operating.
- Never use water to clean control equipment unless you are certain that the equipment has been certified as sealed against water ingress. Water is a very good conductor of electricity and the single largest cause of death by electrocution.

3 Installing the MMC Smart Drive

NOTE

The National Electrical Code and any other governing regional or local codes overrule the information in this manual. Kollmorgen does not assume responsibility for the user's compliance or non-compliance with any code, national, local or otherwise, for the proper installation of this drive and associated systems or equipment. Failure to abide by applicable codes creates the hazard of personal injury and/or equipment damage.

3.1 Storing the Drive Before Installation

The drive should remain in the shipping container prior to installation. If the equipment is not to be used for a period of time, store it as follows:

- Use a clean, dry location
- Maintain the storage temperature and humidity as shown in the specifications section of this manual.
- Store it where it cannot be exposed to a corrosive atmosphere
- Store it in a non-construction area

3.2 Unpacking the Drive

Remove all packing material, wedges, and braces from within and around the components. After unpacking, check the name plate Material Number against the purchase order of the item(s) against the packing list. The model number, serial number and manufacturing date code are located on the side of the unit.

3.3 Handling an MMC Smart Drive

The case protects the MMC Smart Drive's internal circuitry against mechanical damage in shipping and handling.

However, like any electronic device, the circuitry can be destroyed by:

- Conditions exceeding those detailed in the specifications tables shown in the Specifications sections in this manual.
- moisture condensing inside the module
- static discharge
- exposure to a magnetic field strong enough to induce a current in the circuitry
- vibration, and other hazards

3.4 Inspecting the Drive Before Installation

Inspect the unit for any physical damage that may have been sustained during shipment.

If you find damage, either concealed or visible, contact your buyer to make a claim with the shipper. If degraded performance is detected when testing the unit, contact your distributor or Kollmorgen. Do this as soon as possible after receipt of the unit.

3.5 **Complying with European Directives**

For industrial products installed within the European Union or EEC regions, certain directives and standards apply. See “Conformity” in the Specifications sections of Chapters 5 and 6 for applicable directives.

Servo amplifiers are considered to be subsystems when incorporated into electrical plants and machines for industrial use. The Kollmorgen servo amplifiers have been designed and tested as such. They bear the CE mark and are provided with a Declaration of Conformance. However, it is the overall machine or system design that must meet European Directives and standards. To help the manufacturer of the machine or plant meet these directives and standards, specific guidelines are provided in this documentation. These include such things as shielding, grounding, filters, treatment of connectors and cable layout.

3.6 **Conforming with UL and cUL Standards**

Kollmorgen drives meet safety and fire hazard requirements as outlined in “Conformity” in the Specifications sections of [Chapter 14, *Declarations of Conformity*](#).

3.7 **General Installation and Ventilation Requirements**

- The drive must be enclosed in a grounded NEMA12 enclosure offering protection to IP55 such that they are not accessible to an operator or unskilled person, in order to comply with UL[®] and CE requirements. A NEMA 4X enclosure exceeds these requirements providing protection to IP66.
- The environmental conditions must not exceed those detailed in the specifications tables shown in the Specifications sections in this manual.
- Install the panel on a properly bonded, flat, rigid, non-painted galvanized steel, vertical surface that won't be subjected to shock, vibration, moisture, oil mist, dust, or corrosive vapors.
- Maintain minimum clearances for proper airflow, easy module access, and proper cable bend radius.
- Plan the installation of your system so that you can perform all cutting, drilling, tapping, and welding with the drive removed from the enclosure. Because the drive is of the open type construction, be careful to keep any metal debris from falling into it. Metal debris or other foreign matter can become lodged in the circuitry, which can result in damage to components.

The MMC Smart Drive is suitable for operation in a pollution degree 2 environment (i.e., normally, only non-conductive pollution occurs). Install the drive away from all sources of strong electromagnetic noise. Such noise can interfere with MMC Smart Drive operation.

Protect the MMC Smart Drive system from all the following:

- conductive fluids and particles
- corrosive atmosphere
- explosive atmosphere

Diagrams included with this manual and recommendations may be modified if necessary so the wiring conforms to current NEC standards or government regulations.

Location	Minimum Clearance		
	230V SD Drive	460V SD Drive	460V SDN Drive
Above Drive Body	2.0 in. (50.8 mm)	4.0 in. (100 mm)	2.25 in. (57 mm)
Below Drive Body	2.0 in. (50.8 mm)	4.0 in. (100 mm)	2.25 in. (57 mm)
Each Side of Drive	.50 in. (12.7 mm)	None	0.25 in. (6.35 mm)
In Front of Drive (for cabling)	3.0 in. (76.2 mm)	3.0 in. (76.2 mm)	3.0 in. (76.2 mm)

NOTE
Use filtered or conditioned air in ventilated cabinets. The air should be free of contaminants, including but not limited to oil, corrosives, and electrically conductive material.

3.8 Controlling Heat Within the System

The MMC Smart Drive hardware case is designed to promote air circulation and dissipate heat. Normally no fans or air conditioners are needed. However, if the environment outside the control cabinet is hot or humid, you may need to use a fan, heat exchanger, dehumidifier or air conditioner to provide the correct operating environment.

Make sure that the temperature and humidity within the drive cabinet does not exceed that which is shown in the specifications sections of this manual.

Make sure that components installed in the cabinet with the MMC Smart Drive do not raise the temperature above system limits and that any hot spots do not exceed specifications. For example, when heat-generating components such as transformers, other drives or motor controls are installed, separate them from the drive by doing one of the following:

- Place them near the top of the control cabinet so their heat output rises away from the MMC Smart Drive.
- Put them in another control cabinet above or to one side of the cabinet with the MMC Smart Drive. This protects the MMC Smart Drive from both heat and electrical noise.

The MMC Smart Drive itself is a source of heat, though in most installations its heat dissipates without harmful effects. System heat is generated from power dissipated by:

- the drive
- field side input/output components
- other drives in the cabinet

- the logic power supply
- external shunt resistors
- line reactors

CAUTION

If the MMC Smart Drive is operated outside the recommended environmental limits, it may be damaged. This will void the warranty.

3.9 Bonding

Connecting metal chassis, assemblies, frames, shields and enclosures to reduce the effects of electromagnetic interference (EMI) is the process of bonding.

Most paints act as insulators. To achieve a good bond between system components, surfaces need to be paint-free or metal plated. Bonding metal surfaces creates a low-impedance exit path for high-frequency energy. Improper bonding blocks this direct exit path and allows high-frequency energy to travel elsewhere in the cabinet. Excessive high-frequency energy can negatively affect the operation of the drive.

3.9.1 Bonding a Subpanel Using a Stud

1. Weld threaded mounting studs to the back of the enclosure.
2. Brush off any non-conductive materials (e.g. paint) from the studs.
3. Remove any non-conductive materials from the front of the subpanel.
4. Position the mounting holes on the subpanel over the mounting studs on the back of the enclosure and slide the subpanel onto the studs.
5. Attach the subpanel to the mounting stud by sliding a star washer over the stud and then turn and tighten a nut onto the stud.

3.9.2 Bonding a Ground Bus Using a Stud

1. Weld threaded mounting studs to the back of the subpanel.
2. Brush off any non-conductive materials (e.g. paint) from the studs.
3. Slide a flat washer over the studs.
4. Remove any non-conductive materials from around the mounting hole on the chassis mounting bracket or ground bus.
5. Position the mounting hole of the chassis or ground bus over the studs on the back of the subpanel and slide the mounting bracket or ground bus onto the stud.
6. Attach the subpanel to the subpanel stud by sliding a star washer and then a flat washer over the stud. Turn and tighten a nut onto the stud.

3.9.3 Bonding a Ground Bus or Chassis Using a Bolt

1. Brush off any non-conductive materials (e.g. paint) from the threaded bolt (s).
2. Slide a star washer over the threaded bolt (s).
3. Use a subpanel having tapped mounting holes. Remove any non-conductive materials from around the mounting holes on both sides of the subpanel.

4. Turn the threaded bolts into the subpanel mounting holes.
5. Slide a star washer onto the threaded end of the bolt.
6. Turn and tighten a nut onto the stud.
7. Slide a flat washer onto the threaded end of the bolt.
8. Position the mounting holes on the groundbus or mounting bracket over the threaded bolts and turn the bolts until they come through the grounding bus or mounting bracket.
9. Slide a star washer onto the threaded end of the bolt.
10. Slide a flat washer onto the threaded end of the bolt.
11. Turn and tighten a nut onto the bolt.

3.9.4 Grounding Multiple Drive Cabinets

1. Mount one bonded ground bus in each cabinet.
2. Designate the cabinet ground bus in one and only one of the cabinets as the common ground bus for all of the cabinets in the system.
3. Connect the ground wires from the ground bus in each individual cabinet ground bus to the designated common ground bus (mounted in only one of the cabinets).
4. Connect the common cabinet ground bus to an external ground system that is connected to a single point ground.

3.9.5 Bonding Multiple Subpanels

Kollmorgen recommends bonding both the top and bottom of subpanels sharing the same enclosure. Use a 25.4 mm (1.0 in.) x 6.35 mm (0.25) wire braid. Be sure the area around each wire braid fastener is clear of any non-conductive materials. Bond the cabinet ground bus to at least one of the subpanels.

NOTE
Subpanels that are not bonded together may not share a common low impedance path. This difference in impedance may affect networks and other devices that span multiple panels.

3.10 Drive Mounting Guidelines

- A control cabinet for the MMC Smart Drive should have a NEMA-12 rating or better. A cabinet with this rating protects its contents from dust and mechanical damage.
- The cabinet must be large enough to provide adequate air circulation for the MMC Smart Drive and other components. Always allow for adequate air flow through the MMC Smart Drive vents.
- The cabinet must have a rigid non-painted galvanized metal surface to mount the MMC Smart Drive on.

- The cabinet door should open fully for easy access.

IMPORTANT
Post warnings according to National, State, or local codes for the voltage present in the control cabinet. Diagrams included with this manual and recommendations may be modified if necessary so the wiring conforms to current NEC standards or government regulations.

NOTE
This drive contains parts and assemblies that are sensitive to ESD (Electrostatic Discharge). Follow static control precautions during installation, testing, service, or repair of this assembly. Parts and assemblies can be damaged if proper precautions are not taken.

1. Lay out the positions for the drive and accessories in the enclosure.
2. Attach the drive to the cabinet, first using the upper mounting slots of the drive and then the lower. The recommended mounting hardware is M5 metric(#10-32).
3. Tighten all mounting fasteners.

3.11 Drive System Grounding Procedures

The ground of the MMC Smart Drive power source must be connected directly to a **Single Point Ground (SPG)** tie block. The tie block should be made of brass or copper, bolted or brazed to the control cabinet. If the tie block is bolted rather than brazed, scrape away paint or grease at the point of contact. Put star washers between the tie block and the cabinet to ensure good electrical contact.

Metal enclosures of power supplies, drives, etc., should also have good electrical contact with the SPG.

Metal enclosures of power supplies, drives, etc., should also have good electrical contact with the SPG.

CAUTION
The Single Point Ground should be the only common point for all the ground lines. If not, ground loops may cause current flow among components of the system which can interfere with proper operation of the MMC Smart Drive.

Devices to be connected directly to the Single Point Ground include:

- Plant safety ground.
- Protective earth ground(s) from the MMC Smart Drive power terminals.
- The metal panel or cabinet on which the MMC Smart Drive is mounted.
- “Common” or “0 V” lines from power supplies that provide +24 power to devices and external power to the I/O modules and the devices to which they are connected.

- Protective grounds from the devices themselves, such as device drivers, machinery, and operator interface devices.
- Protective earth ground from line and load sides of any AC line filters.
- The ground of the power source of the computer workstation or laptop, if any, from which you monitor the system operation. An AC outlet in the control cabinet is recommended.
- Single point grounds from other control cabinets, if any, in the system.

IMPORTANT

You must ensure that the "0V" or "Common" of all devices connected to the MMC Smart Drive are connected to Single Point Ground (SPG). Failure to do so may result in erratic operation or damage to the MMC Smart Drive and devices connected to it. Examples of devices connected to the MMC Smart Drive include the power source that supplies power to the MMC Smart Drive and devices connected to the MMC Smart Drive PiCPro Port. Note that some devices (for example, a Personal Computer) may have their "0V" and "Protective Earth Ground" connected together internally, in which case only one connection has to be made to SPG for that device. Also note that the AC/DC converter for some portable PCs have chassis connected from the wall plug to the PC. The ground for the AC outlet must be connected to the SPG.

Also, you must ensure that the MMC Smart Drive "Protective Earth Ground" connection is connected to SPG, and that the MMC Smart Drive is mounted to a metal panel or enclosure that is connected to SPG.

3.11.1 Grounding Requirements

Figure 3-1: Example of Grounding Required for CE Compliant Single Phase 230V Drive System

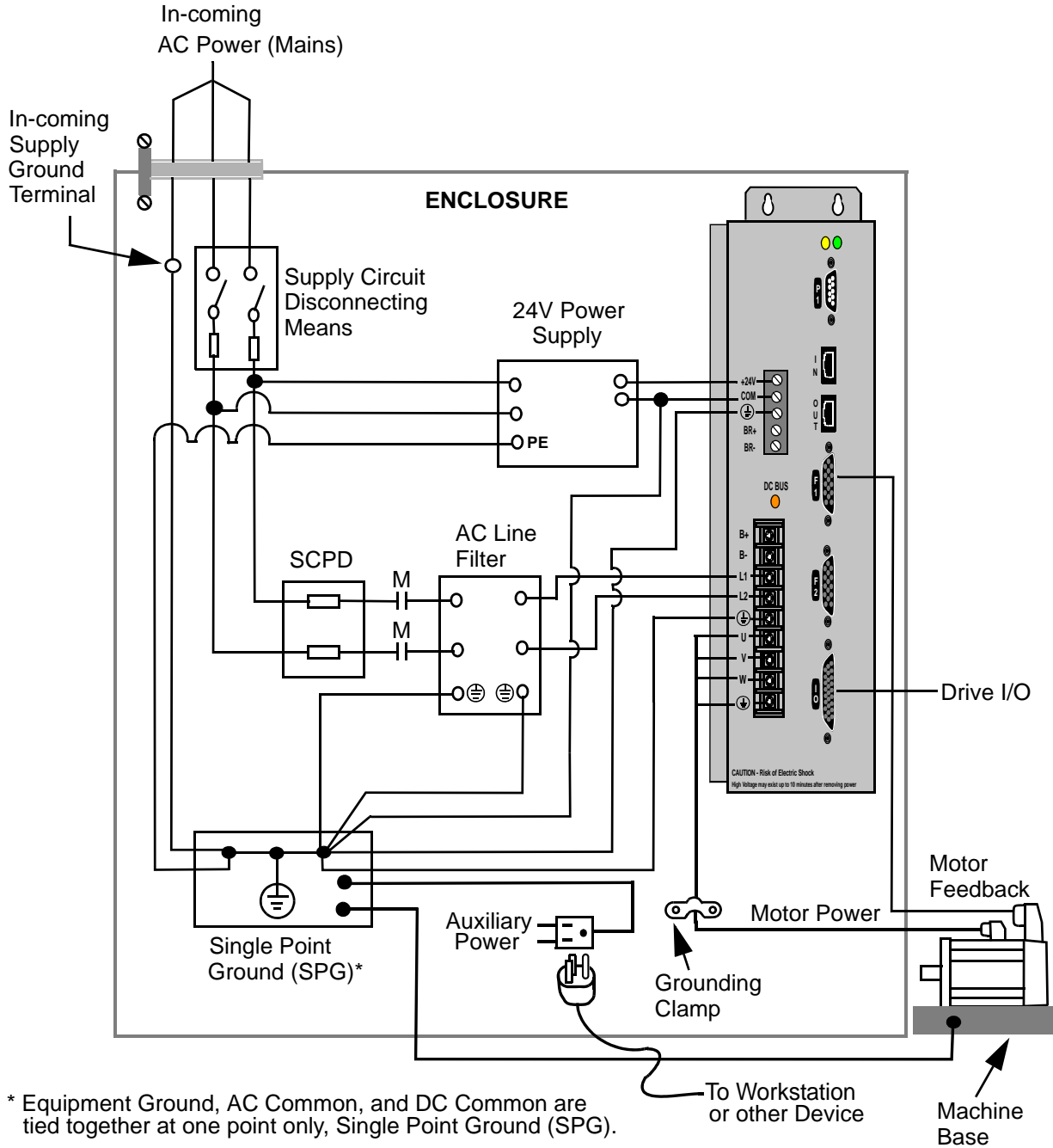

- Mount the filter as close to the Drive as possible. If the distance exceeds 600 mm (2.0 ft), use shielded cable between the Drive and the filter, strapping the shield to chassis at each end of the cable. This is particularly important for attenuation of higher frequency emissions (5-30 MHz).

- Shield or separate the wires connecting the AC power to the filter from other power cables (e.g., connections between the Drive and the filter, motor power cable, etc.). If the connections are not separated from each other, the EMI on the Drive side of the filter can couple over to the source side of the filter, thereby reducing or eliminating the filter’s effectiveness. The coupling mechanism can radiate or allow stray capacitance between the wires.
- Bond the filter and the Drive to a grounded conductive surface (the enclosure) to establish a high frequency (HF) connection. To achieve the HF ground, the contact surface interface between the filter, Drive, and the enclosure should be free from paint or any other type of insulator.
- Size the filter following manufacturer recommendations.
- Provide a large enough ground bar to connect all wires with no more than two wires per connection.
- Clamp motor power cable shield for EMC termination.

IMPORTANT
Filter AC power to the drives to be compliant to CE emission requirements.

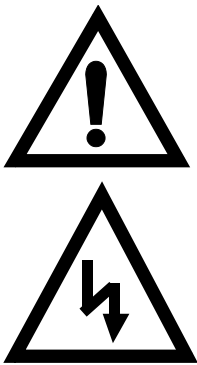
WARNING	
	<p>High voltage exists in AC line filters. The filter must be grounded properly before applying power. Filter capacitors retain high voltages after power removal. Before handling the equipment, voltages should be measured to determine safe levels. Failure to observe this precaution could result in personal injury.</p>

3.11.2 Grounding Multiple Drives in the Same Cabinet

1. Mount a common bonded ground bus in the cabinet.
2. Connect the ground wires for all drives to the common bonded cabinet ground bus.
3. Connect the common bonded cabinet ground bus to an external ground system that is connected to a single point ground.

3.12 System Wiring Guidelines

The MMC Smart Drive relies on electrical signals to report what is going on in the application and to send commands to it. In addition, signals are constantly being

exchanged within the system. The MMC Smart Drive is designed for use in industrial environments, but some guidelines should be followed.

This section contains common system wiring configurations, size, and practices that can be used in a majority of applications. National Electrical Code, local electrical codes, special operating temperatures, duty cycles, or system configurations take precedence over the values and methods provided.

Wherever possible, install wiring and related components in the following order:

1. main power line disconnecting means
2. transformer (optional)
3. fuses (SCPD)
4. motor control
5. line reactor (as required)
6. line filter (optional)
7. device protection fuses (as required)
8. drive
9. shunt resistors (optional)

3.12.1 Recommended Signal Separation

Kollmorgen recommends separation of low level signals (encoder, analog, communications, fast DC inputs) from high voltage or high current lines. Maintain at least two inches of separation.

Inside a control cabinet, connect the shields of shielded cables at the MMC Smart Drive. It is recommended that factory cables (from Kollmorgen) are used between MMC drives, controls, and motors to ensure CE compliance.

WARNING	
	Use care when wiring I/O devices to the MMC Smart Drive and when plugging in cables. Wiring the wrong device to the connector or plugging a connector into the wrong location could cause intermittent or incorrect machine operation or damage to equipment.

WARNING: FEEDBACK DEVICE DAMAGE	
	<p>Feedback Cable Installation and Removal</p> <p>All power to the Smart Drive (24 Vdc and main AC power) must be removed before connecting/disconnecting feedback cable connectors at the Smart Drive (F1 and F2 connector) or at the motor feedback device. Also, all connections must be secure when power is applied. Failure to follow these precautions may result in damage to the feedback device or Smart Drive.</p>

Figure 3-2: Recommended Signal Separation



To prevent excessive conducted emissions from a DC power source (typically 24V) used for digital I/O, a .001 micro farad capacitor should be used. Connect the capacitor from the +24V DC to COMMON at the distribution terminals.

3.12.2 Building Your Own Cables

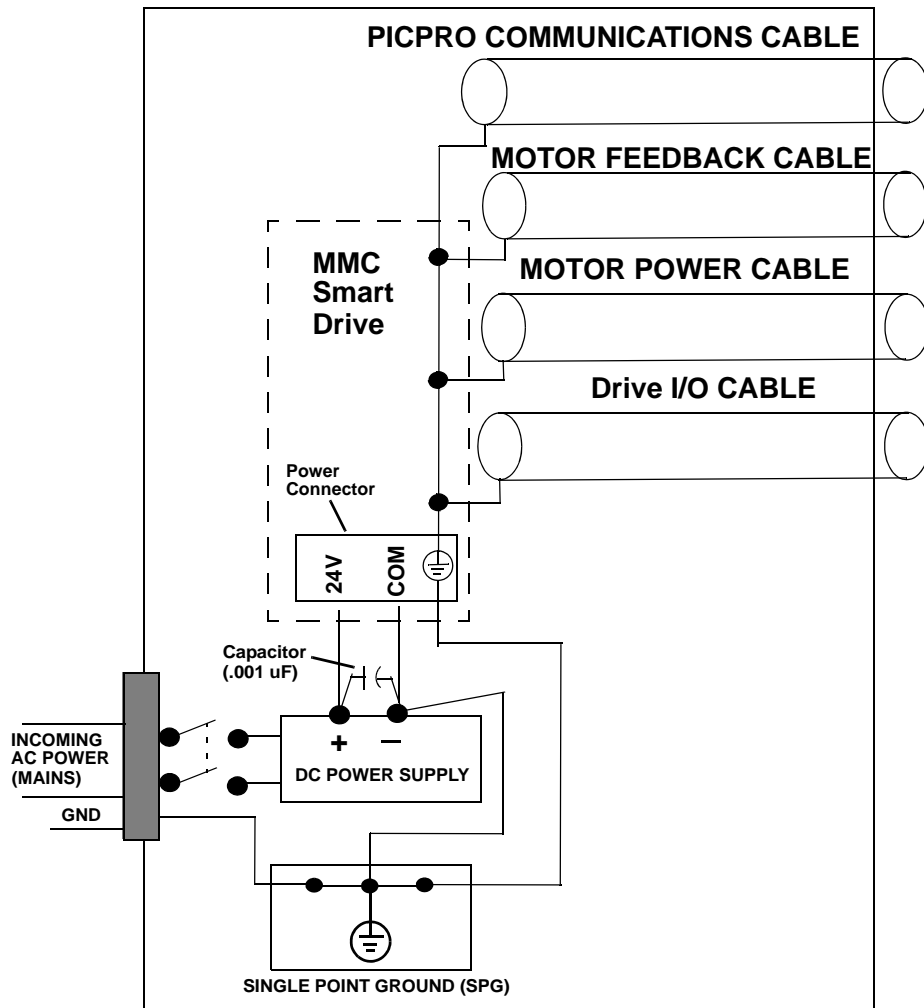
- Connect the cable shield to the connector shells on both ends of the cable for a complete 360 degree connection.
- Use a twisted pair cable whenever possible, twisting differential signals with each other, and single-ended signals with the appropriate ground return.

NOTE
Kollmorgen cables are designed to minimize EMI and are recommended over hand-built cables.

3.12.3 Routing Cables

Guidelines for routing cables in a cabinet include the following:

- Always route power and control cables separately.
- Do not run high and low voltage wires/cable in the same wireway.
- Cross high and low voltage conductors at 90 degree angles.
- On parallel cable runs, maximize the distance between high and low voltage cables.
- Maintain the least amount of unshielded cable leads.

3.13 Wiring the Drive

These procedures assume you have bonded and mounted your MMC Smart Drive to the subpanel and that there is no power applied to the system.

3.13.1 Sizing the 24V Power Supply

When you size your power supply, you must ensure that the supply is large enough to handle the total load. Refer to the specification tables for the +24VDC input power requirements.

In most cases, one power supply can be used for an entire control system. However, depending upon the drives and external I/O used in the application, the power distribution may be split into two or more power supplies.

Use of switches in series with the 24VDC power input is not recommended. The drive contains energy storage capacitors at the inputs. While no harm is done to the drive, this much capacitance across the 24VDC source may cause voltage dips when the switch in series with the 24VDC power is closed.

CAUTION

A possible ignition hazard within the MMC Smart Drive exists if excessive current is drawn from the 24 VDC powering the MMC Smart Drive. To prevent this possibility (due to improper wiring or 24 VDC supply failure), a fuse should be used in series with the 24 VDC to the MMC Smart Drive. Specifically, a 4 A max. "UL248 Series" fuse should be used. In addition, the 24 VDC shall be supplied by an isolating source such that the maximum open circuit voltage available to the MMC Smart Drive is not more than 30 VDC.

The +24V power to the MMC Smart Drive is connected through a Phoenix 5-pin connector with a plug-in terminal block. The ground from the power source and the ground from the MMC Smart Drive must be connected to the Single-Point Ground (SPG). Devices connected to the Drive I/O Port may have their own power sources for input or output control signals provided that each one is:

- at the correct voltage and current levels for the module and the device.
- connected to the same Single-Point Ground that the MMC Smart Drive uses.

It is recommended that the same main disconnect switch be used for the MMC Smart Drive and for all devices in the application.

IMPORTANT

No matter how the system is installed, before you connect the MMC Smart Drive to the application, make sure that power is off to the system and to the devices that are wired to the MMC Smart Drive.

3.13.2 System AC Power Wiring Guidelines

NOTE

In addition to the guidelines listed below, follow all national and local electrical codes and regulations.

- Install a supply circuit disconnecting means.
- Install a Short Circuit Protective Device (SCPD).
- Due to high inrush current at power-up, use dual element time delay fuses for the SCPD.
- Install additional device protection fusing (460V models). Only high speed type fuses provide proper protection.
- Refer to the Specifications sections in [Chapter 4](#) of this manual for device and conductor requirements.
- Clamp the motor power cable shield to the drive using the Kollmorgen supplied bracket. Maximum tightening torque for bracket screws is 10 lb-in.

- Use shielded cables and AC line filters (for CE Compliance). Make sure that wiring from the drive to the line filter is as short as possible. Locate common grounding bus bars as close as possible to the drive. The braid shield of the cable should be clamped at the drive or mounting panel.
- Power connections for each drive in a system should be separately connected directly to the AC power supply. Do not daisy chain drive power connections.
- Make sure the phase to neutral ground voltage does not exceed the input ratings of the drive when using an autotransformer.

3.13.3 Connecting Interface Cables

IMPORTANT
This drive contains ESD (Electrostatic Discharge) sensitive parts and assemblies. Follow static control precautions when installing, testing, servicing, or repairing components in a drive system.

- Plug PiCPro cable into the PiCPro port (9-pin D-shell for the Analog Interfaced MMC-SD, and 6-pin mini-din for the Digital Interfaced MMC-SD).
- Plug the one 15-pin D-shell, Feedback cable into the FBK1 connector.
- Plug the 26-pin D-shell, Drive I/O cable into the I/O connector.
- Tighten the attachment screws for all cables to the drive connectors.

WARNING	
	<p>To avoid personal injury and/or equipment damage:</p> <ul style="list-style-type: none">• Ensure installation complies with specifications regarding wire types, conductor sizes, branch circuit protection, and disconnect devices. The National Electrical Code (NEC) and local codes outline provisions for safely installing electrical equipment.• Ensure motor power connectors are used for connection purposes only. Do not use them to turn the unit on and off.• To avoid personal injury and/or equipment damage, ensure shielded power cables are grounded to prevent potentially high voltages on the shield.

WARNING: FEEDBACK DEVICE DAMAGE	
	<p>Feedback Cable Installation and Removal</p> <p>All power to the Smart Drive (24 Vdc and main AC power) must be removed before connecting/disconnecting feedback cable connectors at the Smart Drive (F1 and F2 connector) or at the motor feedback device. Also, all connections must be secure when power is applied. Failure to follow these precautions may result in damage to the feedback device or Smart Drive.</p>

3.13.4 Preparing Motor Connection Wires

NOTE
<p>It is recommended that Kollmorgen cables be used. Kollmorgen cables are designed to minimize EMI and are recommended over hand-built cables.</p>

1. Strip back cable jacket approximately 152 mm (6.0 in.) from the end of the cable.
2. Strip approximately 12 mm (0.50 in.) of insulation from the end of each conductor. Do not tin ends after stripping.

IMPORTANT
<p>Do not nick, cut or damage wire strands while removing wire insulation.</p>

3. Strip the cable jacket away from the cable until the shield braid is visible. Expose 17 mm (0.68 in.) of cable shield braid.

Figure 3-3: : Motor Cable

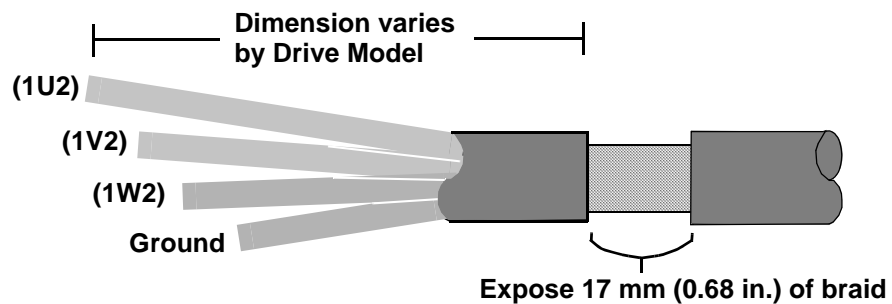

4. Attach the individual wires from the motor cable to their assigned terminal. Refer to Chapters 5 and 6 for front panel connectors and terminal assignments.
5. Tighten each terminal screw.

6. Gently pull on each wire to make sure it does not come out of its terminal. Reinsert and tighten any loose wires.
7. Attach the plastic cover to terminal block

Factory supplied motor power cables for LSM, MSM, FSM, AKM, DDR, CDDR, and YSM Series motors are shielded, and the power cable is designed to be terminated at the drive during installation. A small portion of the cable jacket is removed which exposes the shield braid. The exposed shield braid must be clamped to the drive chassis using the provided clamp and clamp screws

Figure 3-4: Terminating Motor Power Cable for 230V Drive

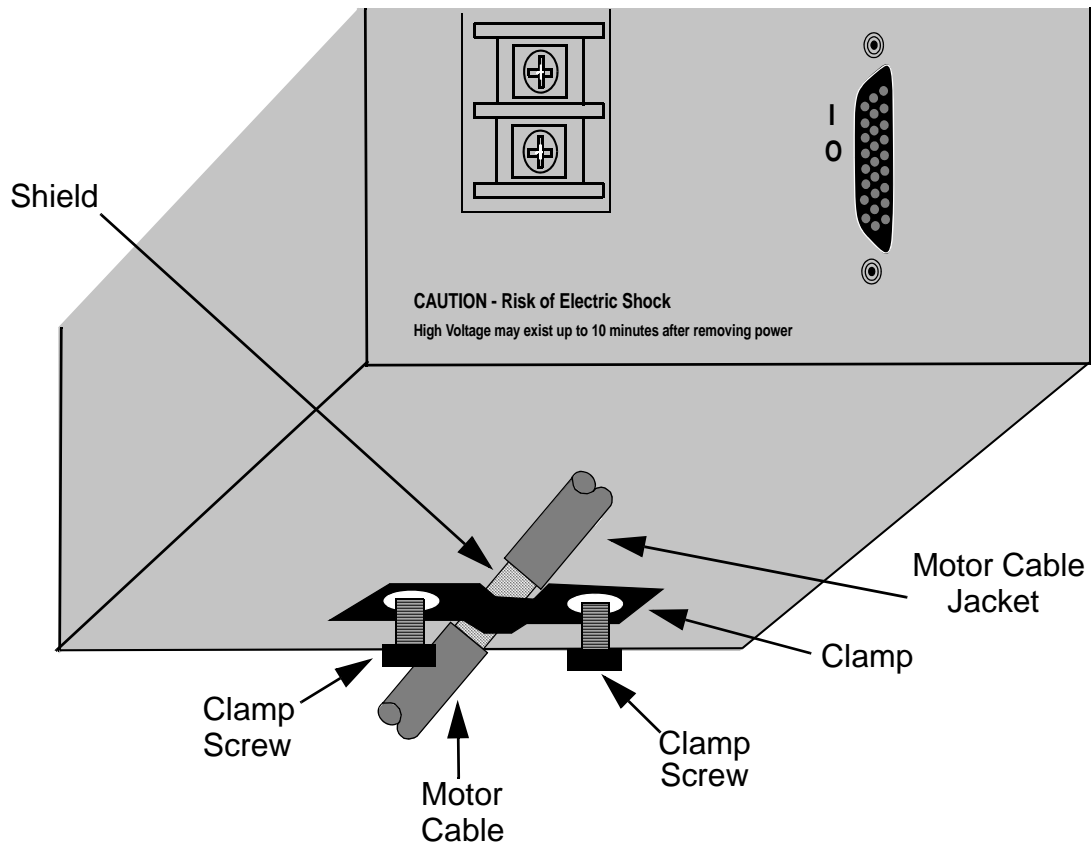

Figure 3-5: Terminating Incoming AC Power (Mains) Cable for 460V SD Drive

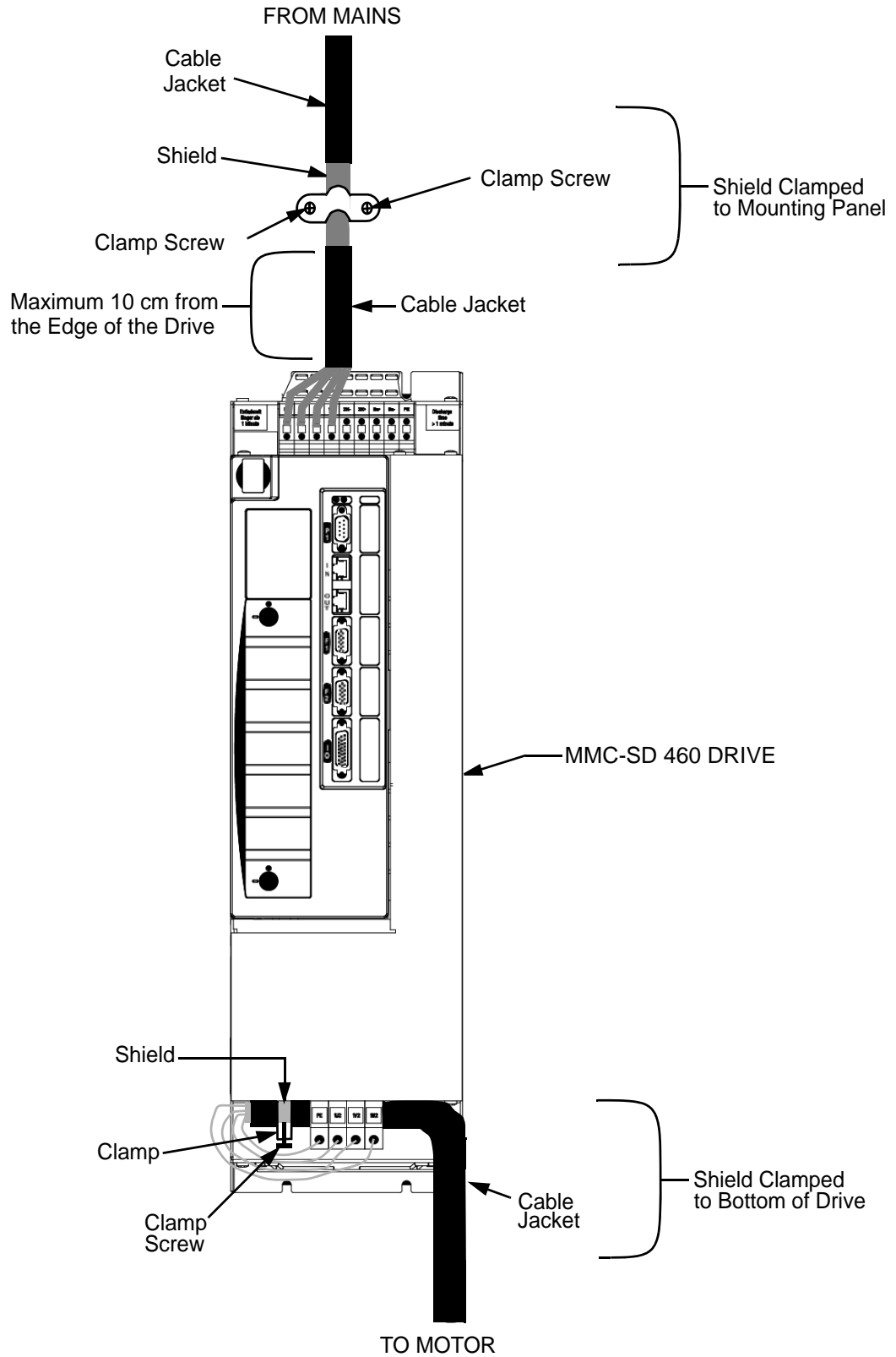
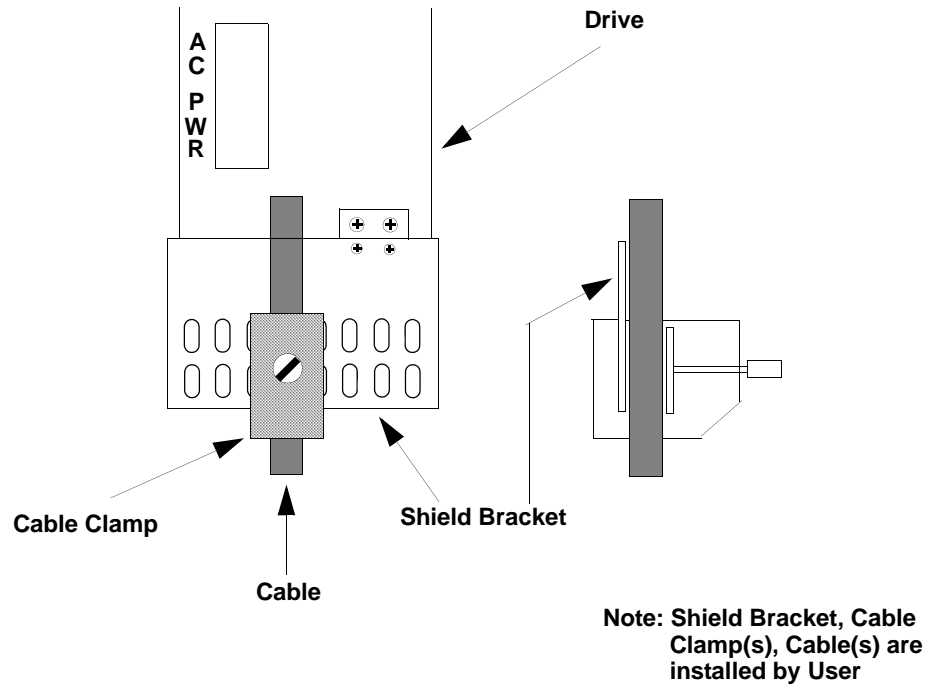

Figure 3-6: Terminating Power Cables for 460V SDN Drive



4 **System Power Devices**

4.1 **AC Input Power Requirements**

The MMC Smart Drive is powered from an external AC power source. The power required for each 230V drive type is listed in [Table 4-1](#). The power required for each 460V drive type is listed in [Table 4-2](#).

Table 4-1: 230V Drive AC Input Power Requirements				
Drive Model^a	Requirements			
	Nominal Input Current Amps_{RMS} 1-phase (3-phase)		Transformer kVA^b 1-phase (3-phase)	
	Input Voltage = 120VAC	Input Voltage = 230VAC	Input Voltage = 120VAC	Input Voltage = 230VAC
MMC-SD-0.5-230	5 (3)	5 (3)	.75 (.5)	1.5 (1)
MMC-SD-1.0-230	9 (5)	9 (5)	1.5 (.75)	2 (1.5)
MMC-SD-2.0-230	18 (10)	18 (10)	2.5 (1.5)	4 (2.5)
MMC-SD-3.0-230	18 (14)	18 (14)	2.5 (2)	4 (4)
S20260-DLS	3.4(N/A)	3.4(2.7)	CF ^c	CF
S20360-DLS	6.5(N/A)	6.5(5.0)	CF	CF
S20660-DLS	12(N/A)	12(9.0)	CF	CF
S21260-DLS	N/A(N/A)	18(16)	CF	CF
S22460-DLS	N/A(N/A)	22(24)	CF	CF
S20250-DLS	5(N/A)	3.4(N/A)	CF(N/A)	CF(N/A)
S20350-DLS	10(N/A)	6.5(N/A)	CF(N/A)	CF(N/A)

- a. Smart Drive (SD) Drive Model pertains to Analog (no dash suffix) and digital (-D & -DN)
- b. Transformer sizes shown are worse-case. For a more accurate determination of transformer size, see [section 4.4 on page 57](#) for calculating application transformer requirement.
- c. Consult Factory

Table 4-2: 460V Drive AC Input Power Requirements				
Drive Model ^a	Requirements			
	Nominal Input Current Amps _{RMS} 3-phase		Transformer kVA ^b 3-phase	
	Input Voltage = 230VAC	Input Voltage = 460VAC	Input Voltage = 230VAC	Input Voltage = 460VAC
MMC-SD-1.3-460	2.8	2.44	1.2	3.0
MMC-SD-2.4-460	4.8	4.18	2.0	5.0
MMC-SD-4.0-460	8.1	7.0	3.4	8.5
MMC-SD-6.0-460	12.4	10.8	5.2	12.8
MMC-SD-8.0-460	17.0	14.8	7.0	17.6
MMC-SD-12.0-460	19.2	16.7	8.0	19.5
MMC-SD-16.0-460	24.2	21.1	10.0	25.0
MMC-SD-24.0-460	38.0	33.1	16.0	39.5
MMC-SD-30.0-460	53.0	46.0	22.0	55.0
MMC-SD-42.0-460	70.0	70.0	29.0	73.0
MMC-SD-51.0-460	84.0	73.0	35.0	87.0
MMC-SD-65.0-460	105	91.0	44.0	110
MMC-SD-72.0-460	101	101	54	107
MMC-SD-100-460	127	127	67	184
MMC-SD-144-460	185	185	85	170
MMC-SDN-1.8-460	2.7	2.7	CF ^c	CF
MMC-SDN-3.6-460	5.4	5.4	CF	CF
MMC-SDN-7.2-460	9.2	9.2	CF	CF
MMC-SDN-14.4-460	18.3	18.3	CF	CF

a. Smart Drive (SD) Model pertains to Analog (no dash suffix) and digital (-D & -DN)

b. Transformer sizes shown are worse-case. For a more accurate determination of transformer size, see [section 4.4 on page 57](#) for calculating application transformer requirement.

c. Consult Factory

4.2 Protection

4.2.1 Motor Overload Protection

The MMC Smart Drive utilizes solid state motor overload protection in accordance with UL508C that operates:

- within 30 minutes at 125% overload
- within 8 minutes at 200% overload
- within 20 seconds at 600% overload

4.2.2 Motor Thermal Protection

The Drives described in this manual do not provide motor over-temperature sensing, unless a motor-mounted thermal device is connected to the Drive as described below.

In order to provide Motor Thermal Protection, and to meet the requirements of UL508C, the following must be followed:

- One of the following temperature-sensing devices must be installed in the motor:
 - A thermostat (normally closed, contacts rated at 10ma, 3.3VDC or greater). The thermostat's contact will open when the motor's maximum operating temperature is exceeded. Connect the thermostat between 0V and the Thermostat input of the Drive's Feedback Connector.
 - A thermistor (rated at 10ma, 3.3VDC or greater; Philips KTY84-130 PTC or equivalent recommended). The motor manufacturer will provide the motor's maximum operating temperature. This temperature may be entered into the Motor Temperature Parameters in PiCPro. Connect the thermistor output between 0V and the Thermistor input on the Drive's Feedback Connector.
- The temperature-sensing device must be properly connected to the drive (as described elsewhere in this manual)
- The temperature-sensing device must be properly configured in PiCPro (as described in the PiCPro Manual and/or PiCPro on-line Help)

4.2.3 S200-DLS Drive Protection Requirements

Two types of Protection must be provided in case the S200-DLS Drive malfunctions:

- Short Circuit Protection - this protection helps minimize damage to the Smart Drive in the case of a Short Circuit condition. Short Circuit Protection is required to meet UL508C requirements.
- Branch Circuit Over Current Protection - this protection helps minimize damage to the Smart Drive and helps protect the wiring between the Smart Drive and the Over Current Protection Device in the case of a sustained Over Current condition. Over Current Protection must be provided in accordance with NFPA 79 7.2.3 and 7.2.10. Supplemental UL1007 protectors **shall not** be used to provide Branch Circuit Protection.

When using the S200-DLS Drive, the fuse that provides Short Circuit Protection also provides Over Current Circuit Protection, therefore a separate Short Circuit Protection fuse is not required.

Two types of fuses are defined for use with the S200-DLS Drive:

Non-restricted - If the Branch Circuit supplying power to the drive is capable of delivering no more than 5,000 RMS symmetrical short circuit amperes (240V maximum), the fuse type provided for Protection has no “Clearing I^2t ” restrictions, and must meet the following requirements:

- have a current rating no greater than the “Maximum Fuse Size” in [Table 4-3](#)
- have an interrupt capability no less than the short circuit rating (Prospective Short-circuit Symmetrical Amperes) of the Branch Circuit supplying the drive.

Restricted - If the Branch Circuit supplying power to the drive is capable of delivering between 5,000 and 100,000 RMS symmetrical short circuit amperes (240V maximum), the fuse type provided for Protection has “Clearing I^2t ” restrictions, and must meet the following requirements:

- meet both of the requirements for a non-restricted fuse (above)
- be a Class RK1, J, or CC dual element current limiting fuse

The requirements for both restricted and non restricted fuses may be met by using a single fuse that meets all requirements. The easiest way to accomplish this is to use a “Current Limiting Fuse” from [Table 4-3](#). These fuses meet all of the requirements for both Short Circuit Protection and Over Current Protection, and may be used on Branch Circuits that supply up to 100,000 RMS symmetrical short circuit amperes (240V maximum).

The maximum fuse size allowed for use with each S200-DLS Drive, as well as suggested Bussmann fuses that meet both the restricted and non-restrictive requirements as described above, is listed in [Table 4-3](#).

NOTE

The Drive is suitable for use on a branch circuit capable of delivering not more than 100,000 RMS symmetrical Amperes, 240 Volts maximum, when protected by proper fuses (or equivalent), as described in this section.

UL REQUIREMENTS
In order to meet UL requirements for the S200-DLS Drive, the over-current protection device (fuses) must be UL-Listed Class RK1, J, or CC

Table 4-3: S200-DLS Drive Protection Devices			
S200-DLS Drive Model	Maximum Fuse Size^a (Bussmann Fuse P/N)		
	V_{IN} = 120VAC 1 Phase	V_{IN} = 240VAC 1 Phase	V_{IN} = 240VAC 3 Phase
S20260-DLS	5A (LPJ-5SP)	5A (LPJ-5SP)	5A (LPJ-5SP)
S20360-DLS	10A (LPJ-10SP)	10A (LPJ-10SP)	8A (LPJ-8SP)
S20660-DLS	20A (LPJ-20SP)	20A (LPJ-20SP)	15A (LPJ-15SP)
S21260-DLS	N/A	30A (JKS-30)	20A (JKS-20)
S22460-DLS	N/A	30A (JKS-30)	30A (JKS-30)
S20250-DLS	10A (LPJ-10SP)	5A (LPJ-5SP)	N/A
S20350-DLS	20A (LPJ-20SP)	10A (LPJ-10SP)	N/A
	V_{IN} = 90VDC		
S20330-DLS	7A (LP-CC-7)		
S20630-DLS	15A (LP-CC-15)		

a. This is the maximum fuse size that can be used for Device Protection

ATTENTION

The opening of branch-circuit protective device may be an indication that a fault has been interrupted. To reduce the risk of fire or electric shock, current-carrying parts and other components of the controller should be examined and replaced if damaged.

4.2.4 230V Smart Drive Protection Requirements

Two types of Protection must be provided in case the Smart Drive malfunctions:

- Short Circuit Protection - this protection helps minimize damage to the Smart Drive in the case of a Short Circuit condition. Short Circuit Protection is required to meet UL508C requirements.
- Branch Circuit Over Current Protection - this protection helps minimize damage to the Smart Drive and helps protect the wiring between the Smart Drive and the Over Current Protection Device in the case of a sustained Over Current condition. Over Current Protection must be provided in accordance with NFPA 79 7.2.3 and 7.2.10. Supplemental UL1007 protectors **shall not** be used to provide Branch Circuit Protection.

When using the 230V Smart Drive, the fuse that provides Short Circuit Protection also provides Over Current Circuit Protection, therefore a separate Short Circuit Protection fuse is not required.

Two types of fuses are defined for use with the 230V Smart Drive:

Non-restricted - If the Branch Circuit supplying power to the drive is capable of delivering no more than 5,000 RMS symmetrical short circuit amperes (240V maximum), the fuse type provided for Protection has no “Clearing I^2t ” restrictions, and must meet the following requirements:

- have a current rating no greater than the “Maximum Fuse Size” in [Table 4-4](#)
- have an interrupt capability no less than the short circuit rating (Prospective Short-circuit Symmetrical Amperes) of the Branch Circuit supplying the drive.

Restricted - If the Branch Circuit supplying power to the drive is capable of delivering between 5,000 and 100,000 RMS symmetrical short circuit amperes (240V maximum), the fuse type provided for Protection has “Clearing I^2t ” restrictions, and must meet the following requirements:

- meet both of the requirements for a non-restricted fuse (above)
- be a Class RK1, J, or CC dual element current limiting fuse

The requirements for both restricted and non restricted fuses may be met by using a single fuse that meets all requirements. The easiest way to accomplish this is to use a “Current Limiting Fuse” from [Table 4-4](#). These fuses meet all of the requirements for both Short Circuit Protection and Over Current Protection, and may be used on Branch Circuits that supply up to 100,000 RMS symmetrical short circuit amperes (240V maximum).

The maximum fuse size allowed for use with each 230V Smart Drive, as well as suggested Bussmann fuses that meet both the restricted and non-restrictive requirements as described above, is listed in [Table 4-4](#).

NOTE
The Drive is suitable for use on a branch circuit capable of delivering not more than 100,000 RMS symmetrical Amperes, 240 Volts maximum, when protected by proper fuses (or equivalent), as described in this section.

UL REQUIREMENTS
In order to meet UL requirements for the 230V Smart Drive, the over-current protection device (fuses) must be UL-Listed Class RK1, J, or CC

230V Drive Model^a	Maximum Fuse Size^b (Bussmann Fuse P/N)		
	V_{IN} = 120VAC 1 Phase	V_{IN} = 240VAC 1 Phase	V_{IN} = 240VAC 3 Phase
MMC-SD-0.5-230	12A (LPJ-12SP)	12A (LPJ-12SP)	12A (LPJ-12SP)
MMC-SD-1.0-230	15A (LPJ-15SP)	15A (LPJ-15SP)	15A (LPJ-15SP)
MMC-SD-2.0-230	30A (LPJ-30SP)	30A (LPJ-30SP)	25A (LPJ-25SP)
MMC-SD-3.0-230	30A (LPJ-30SP)	30A (LPJ-30SP)	25A (LPJ-25SP)

a. Drive model pertains to Analog (no dash suffix) and Digital (-D & -DN) versions

b. This is the maximum fuse size that can be used for Device Protection

ATTENTION
The opening of branch-circuit protective device may be an indication that a fault has been interrupted. To reduce the risk of fire or electric shock, current-carrying parts and other components of the controller should be examined and replaced if damaged.

4.2.5 460V Smart Drive Protection Requirements

Although these drives provide solid state motor overload protection at 125% of the rated FLA Current and short circuit protection, this Integral solid state short circuit protection does not provide branch circuit protection. Branch circuit protection must be provided in accordance with the National Electrical Code and any additional local codes, as described in this section.

NOTE

The Drive is suitable for use on a circuit capable of delivering not more than 100,000 RMS symmetrical Amperes, 480 Volts maximum, when protected by proper fuses (or equivalent), as described in this section.

Two types of Protection must be provided in case the Smart Drive malfunctions:

- Short Circuit Protection - this protection helps minimize damage to the Smart Drive in the case of a Short Circuit condition. Short Circuit Protection is required to meet UL508C requirements.
- Branch Circuit Over Current Protection - this protection helps minimize damage to the Smart Drive and helps protect the wiring between the Smart Drive and the Over Current Protection Device in the case of a sustained Over Current condition. Over Current Protection must be provided in accordance with NFPA 79 7.2.3 and 7.2.10. Supplemental UL1007 protectors **shall not** be used to provide Branch Circuit Protection.

Two types of fuses are defined for use with the 460V Smart Drive:

Non-restricted - If the Branch Circuit supplying power to the drive is capable of delivering no more than 5,000 RMS symmetrical short circuit amperes (480V maximum), the fuse type provided for Protection has no “Clearing I^2t ” restrictions, and must meet the following requirements:

- have a current rating no greater than the “Maximum Fuse Size” in [Table 4-5](#)
- have an interrupt capability no less than the short circuit rating (Prospective Short-circuit Symmetrical Amperes) of the Branch Circuit supplying the drive.

Restricted - If the Branch Circuit supplying power to the drive is capable of delivering between 5,000 and 100,000 RMS symmetrical short circuit amperes (480V maximum), the fuse type provided for Protection has “Clearing I^2t ” restrictions, and must meet the following requirements:

- meet both of the requirements for a non-restricted fuse (above)
- have a “Clearing I^2t ” rating no greater than the “Clearing I^2t ” rating in [Table 4-5](#)

The requirements for both restricted and non restricted fuses may be met by using one of two methods:

- Use a single fuse that meets all requirements. The easiest way to accomplish this is to use a “Combination Fuse” from [Table 4-5](#). These fuses meet all of the requirements for both Short Circuit Protection and Over Current Protection, and may be used on Branch Circuits that supply up to 100,000 RMS symmetrical short circuit amperes (480V maximum).

- Use two fuses connected in series, that, in combination, meet all of the requirements:
 - Use an Over Current Protection fuse that has a current rating not greater than the “Maximum Fuse Size” shown in [Table 4-5](#), and an interrupt capability not less than the short circuit rating (Prospective Short-circuit Symmetrical Amperes) of the Branch Circuit supplying the drive.
 - Use a Short circuit Protection fuse (typically a semiconductor fuse) that has a “Clearing I^2t ” rating not greater than that shown in [Table 4-5](#), and a current rating greater than the Over Current Protection fuse (to avoid nuisance tripping).

See [Table 4-6 on page 49](#) to for a listing of available fuses and fuse holders from Kollmorgen.

NOTE

The Drive is suitable for use on a branch circuit capable of delivering not more than 100,000 RMS symmetrical Amperes, 480 Volts maximum, when protected by proper fuses (or equivalent), as described in this section.

UL REQUIREMENTS

In order to meet UL requirements for the 460V Smart Drive, the over-current protection device (fuses) must be UL-Listed Class J

Table 4-5: 460V Smart Drive Protection Devices

460V Drive Model ^a	I^2t Rating ^b	Maximum Fuse Size ^c		Recommended Fuse Ferraz (Bussmann) ^{d,e}	
		$V_{IN} = 230VAC$	$V_{IN} = 460VAC$	$V_{IN} = 230VAC$	$V_{IN} = 460VAC$
MMC-SD-1.3-460	$< 228A^2s$	11A	9A	HSJ6(DFJ6)	HSJ6(DFJ6)
MMC-SD-2.4-460	$\leq 228A^2s$	19A	16A	HSJ15(DFJ15)	HSJ15(DFJ15)
MMC-SD-4.0-460	$\leq 260A^2s$	32A	27A	HSJ15(DFJ15)	HSJ15(DFJ15)
MMC-SD-6.0-460	$\leq 340A^2s$	49A	41A	HSJ20(DFJ20)	HSJ20(DFJ20)
MMC-SD-8.0-460	$\leq 616A^2s$	68A	56A	HSJ30(DFJ30)	HSJ25(DFJ25)
MMC-SD-12.0-460	$\leq 1, 555A^2s$	76A	64A	HSJ35(DFJ35)	HSJ30(DFJ30)
MMC-SD-16.0-460	$\leq 1, 555A^2s$	96A	80A	HSJ40(DFJ40)	HSJ35(DFJ35)
MMC-SD-24.0-460	$\leq 1, 555A^2s$	152A	126A	HSJ60(DFJ60)	HSJ45(DFJ45)
MMC-SD-30.0-460	$\leq 15,000A^2s$	212A	176A	N/A ^f (DFJ80)	N/A ^f (DFJ60)
MMC-SD-42.0-460	$\leq 15,000A^2s$	280A	233A	HSJ125(DFJ125)	HSJ100(DFJ100)
MMC-SD-51.0-460	$\leq 83,700A^2s$	336A	280A	HSJ150(DFJ150)	HSJ110(DFJ110)
MMC-SD-65.0-460	$\leq 83,700A^2s$	420A	350A	HSJ175(DFJ175)	HSJ125(DFJ125)
MMC-SD-72.0-460	$\leq 97,000A^2s$	404	388	HSJ175(DFJ175)	HSJ150(DFJ150)
MMC-SD-100-460	$\leq 97,000A^2s$	508	488	HSJ225(DFJ225)	HSJ225(DFJ200)
MMC-SD-144-460	$\leq 97,000A^2s$	740	711	HSJ350(DFJ350)	HSJ300(DFJ300)
MMC-SDN-1.8-460	$< 685A^2s$	11A	10A	HSJ6(DFJ6)	HSJ6(DFJ6)
MMC-SDN-3.6-460	$< 685A^2s$	22A	21A	HSJ10(DFJ10)	HSJ10(DFJ10)
MMC-SDN-7.2-460	$\leq 685A^2s$	37A	35A	HSJ15(DFJ15)	HSJ15(DFJ15)
MMC-SDN-14.4-460	$\leq 3,850A^2s$	73A	70A	HSJ30(DFJ30)	HSJ30(DFJ30)

a. Drive model pertains to analog (no dash suffix) and Digital (-D)

b. This is the maximum "Clearing I^2t Rating" of a fuse used for Device Protection. Use a fuse that falls in the operating point below the stated release integral (I^2t). All of the listed "Combination Fuses" meet this requirement.

- c. This is the maximum fuse size that can be used for Device and Branch Circuit Protection. Kollmorgen recommends the use of HSJ or DFJ fuses only.
- d. Kollmorgen part numbers for these fuses can be found in [Table 4-6 on page 49](#)
- e. Listed devices are UL Recognized. These fuses have an Interrupt current of 100,000A
- f. Combination fuse not available from Ferraz for this drive

ATTENTION

The opening of branch-circuit protective device may be an indication that a fault has been interrupted. To reduce the risk of fire or electric shock, current-carrying parts and other components of the controller should be examined and replaced if damaged.

Table 4-6: Available Fuses & Holders			
Combination Fuse	Fuse Part Number	Fuse Holder Type 3P	Fuse Holder Part Number
DFJ6	M.3000.0190	30 Amp	M.1016.1046
DFJ10	M.3000.1321	30 Amp	M.1016.1046
DFJ15	M.3000.0191	30 Amp	M.1016.1046
DFJ20	M.3000.0192	30 Amp	M.1016.1046
DFJ25	M.3000.0193	30 Amp	M.1016.1046
DFJ30	M.3000.0194	30 Amp	M.1016.1046
DFJ35	M.3000.0195	60 Amp	M.1016.0612
DFJ40	M.3000.0196	60 Amp	M.1016.0612
DFJ45	M.3000.0197	60 Amp	M.1016.0612
DFJ60	M.3000.0198	60 Amp	M.1016.0612
DFJ80	M.3000.0199	100 Amp	M.1016.0613
DFJ100	M.3000.0200	100 Amp	M.1016.0613
DFJ110	M.3000.0201	200 Amp	M.1016.0614
DFJ125	M.3000.0202	200 Amp	M.1016.0614
DFJ150	M.3000.0203	200 Amp	M.1016.0614
DFJ175	M.3000.0204	200 Amp	M.1016.0614
DF200	CF ^a	CF	CF
DFJ225	CF	CF	CF
DFJ300	CF	CF	CF
DFJ350	CF	CF	CF

a. Consult Factory

4.3 Line Reactors

AC Line Reactors are required when using some models of the MMC Smart Drive. They protect the drive from impermissible rates of current change and reduce harmonic current distortions. When required, they are mounted between the drive and the mains input power source.

NOTE
<p>Multiple drives or inverters on a common power line require one reactor per drive. Individual reactors provide filtering between each drive (and thereby reduce crosstalk) and also provide optimum surge protection for each unit. A single reactor serving several drives does not provide adequate protection, filtering or harmonic reduction when the system is partially loaded. Refer to Figure 4-1 for an example of one line reactor connected to one drive.</p>

WARNING	
	<p>Danger Electric Shock Risk</p>
<p>The frame of line/load reactors must be grounded at one of the reactor mounting holes typically by using a star washer under the heads of the mounting bolts. INJURY OR DEATH MAY RESULT IF THESE SAFETY PRECAUTIONS ARE NOT OBSERVED.</p>	

Figure 4-1: Line Reactor Connection (Simplified)



Line reactors are not necessary for the 230V MMC Smart Drives or the 460V size 1 and 2 MMC Smart Drives. Line reactors are required for the 460V size 3 and size 4 MMC Smart Drives.

4.3.1 Specifications and Dimensions for Required Line Reactors

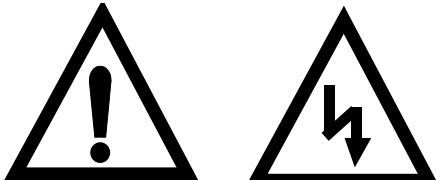
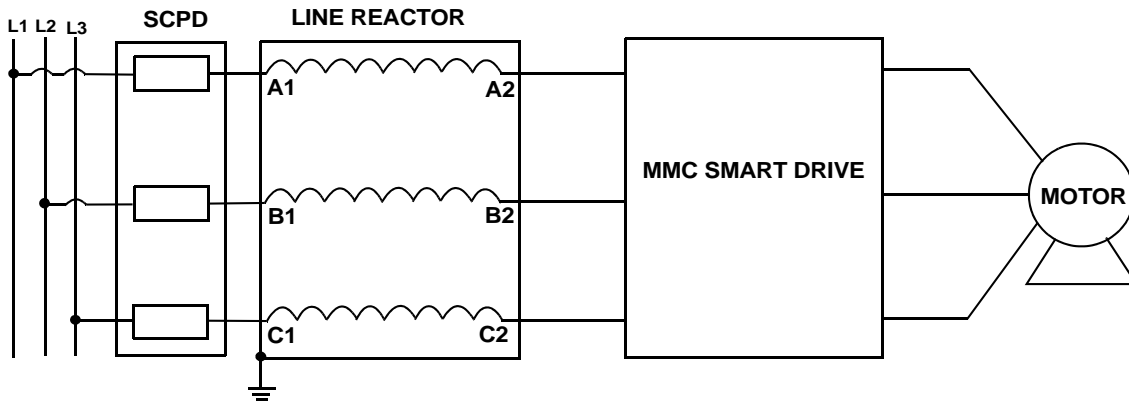
Table 4-7: MMC-SD-12-460 Line Reactor Specifications				
Fundamental Amperage	Power Loss	Inductance	Weight	Part Number
25A	52W	1.2 mH	14 lbs.	M.1302.7373

0.38 x 0.75 (4 SLOTS)

3.00

3.43 MAX

2.35

LABEL

WIRE RANGE: 22-5 AWG

CAUTION - TERMINAL SCREW TIGHTENING TORQUE: 16 in-lb MAX

6.00 MAX

7.25 MAX

Table 4-8: MMC-SD-16-460 Line Reactor Specifications				
Fundamental Amperage	Power Loss	Inductance	Weight	Part Number
35A	54W	0.8 mH	16 lbs.	M.1302.7374

0.38 x 0.75 (4 SLOTS)

3.00

4.00 MAX

2.63

LABEL

WIRE RANGE: 22-5 AWG

CAUTION - TERMINAL SCREW TIGHTENING TORQUE: 16 in-lb MAX

5.75 MAX

7.25 MAX

Table 4-9: MMC-SD-24-460 Line Reactor Specifications

Fundamental Amperage	Power Loss	Inductance	Weight	Part Number
45A	62W	0.7 mH	28 lbs.	M.1302.7375

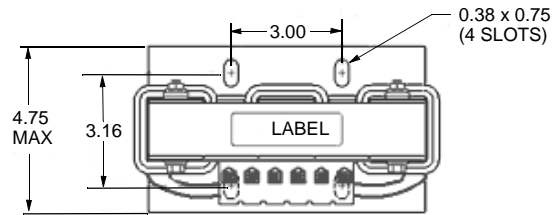

WIRE RANGE: 18-4 AWG

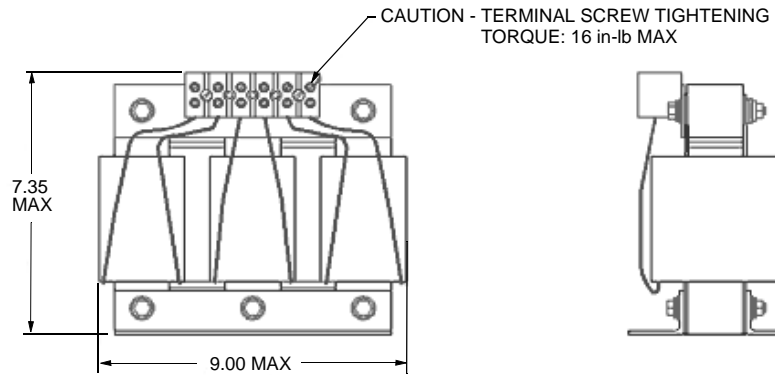
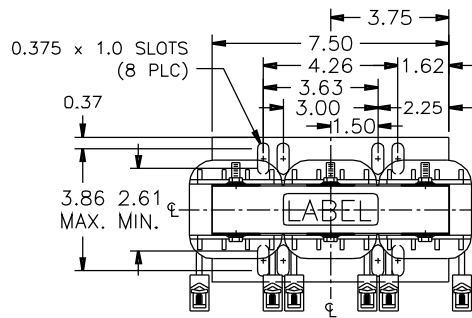

Table 4-10: MMC-SD-30-460 Line Reactor Specifications

Fundamental Amperage	Power Loss	Inductance	Weight	Part Number
55A	67W	0.5 mH	27 lbs.	M.3000.0105



WIRE RANGE: 6-0 AWG

NOTE:
CENTER LINE REPRESENTS
CENTER OF REACTOR CORE

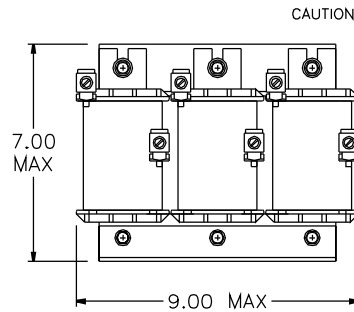

CAUTION-TERMINAL SCREW TIGHTENING
TORQUE: 6-4 (45) in-lb MAX.
2-0 (50) in-lb MAX.

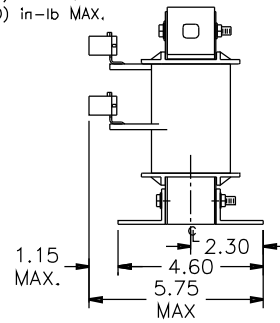
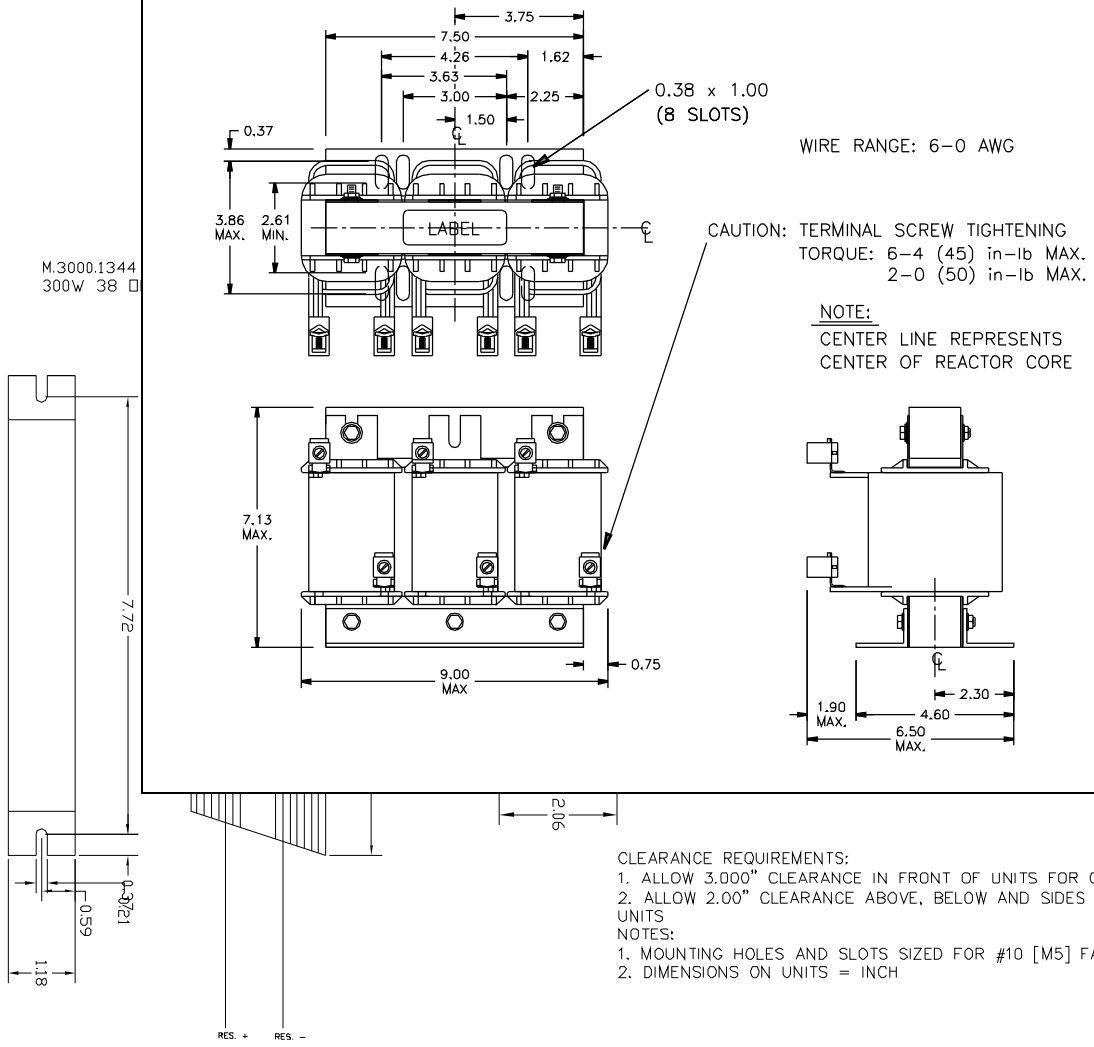

Table 4-11: MMC-SD-42-460 Line Reactor Specifications				
Fundamental Amperage	Power Loss	Inductance	Weight	Part Number
80A	86W	0.4 mH	51 lbs.	M.3000.0106



CLEARANCE REQUIREMENTS:
 1. ALLOW 3.00" CLEARANCE IN FRONT OF UNITS FOR CABLING
 2. ALLOW 2.00" CLEARANCE ABOVE, BELOW AND SIDES OF UNITS

NOTES:
 1. MOUNTING HOLES AND SLOTS SIZED FOR #10 [M5] FASTNER
 2. DIMENSIONS ON UNITS = INCH

Table 4-12: MMC-SD-51-460 Line Reactor Specifications

Fundamental Amperage	Power Loss	Inductance	Weight	Part Number
100A	84W	0.3 mH	51 lbs.	M.3000.0107

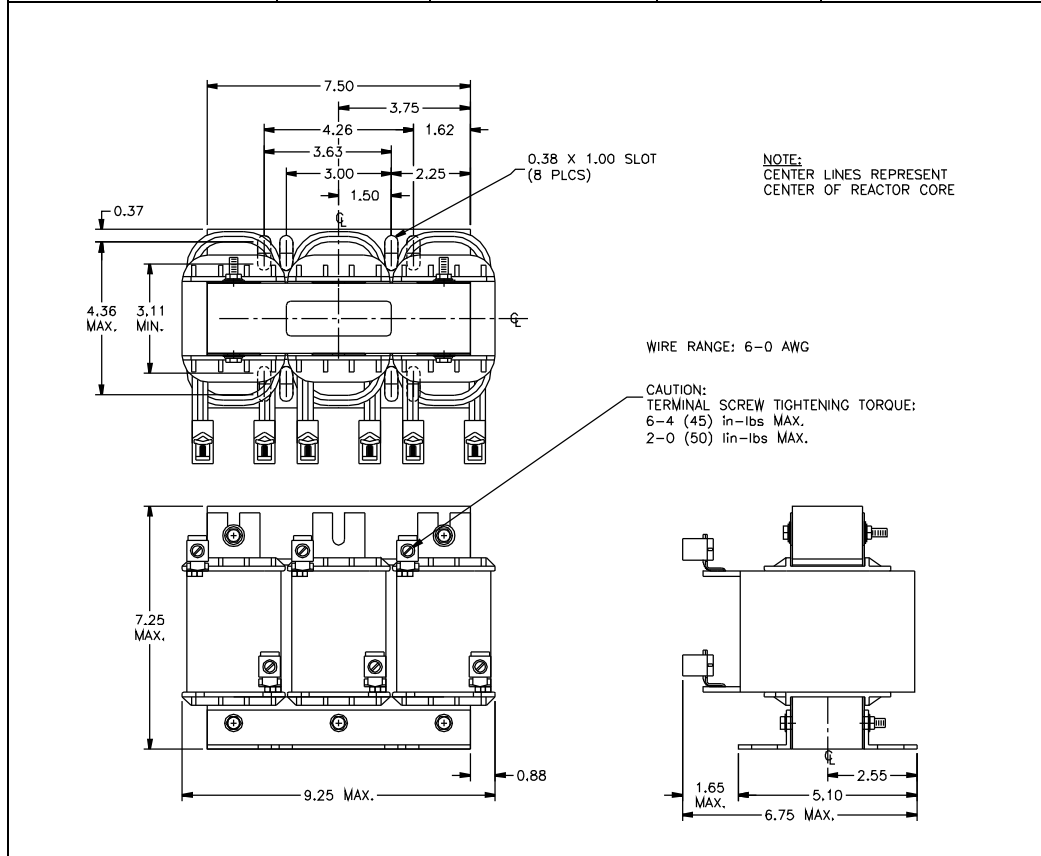

Table 4-13: MMC-SD-65-460 Line Reactor Specifications				
Fundamental Amperage	Power Loss	Inductance	Weight	Part Number
130A	180W	0.2 mH	57 lbs.	M.3000.0108

0.38 x 1.00 (8 SLOTS)

WIRE RANGE: 2-0000 AWG

CAUTION: TERMINAL SCREW TIGHTENING TORQUE: 150 in-lb MAX.

NOTE: CENTER LINE REPRESENTS CENTER OF REACTOR CORE

Dimensions shown in drawing: 7.50, 3.75, 4.26, 1.62, 3.63, 3.00, 2.25, 1.50, 0.37, 4.36 MAX., 3.11 MIN., 7.13 MAX., 9.25 MAX., 0.88, 1.65 MAX., 5.10, 6.75 MAX., 2.55.

4.4 Isolation Transformers

The MMC Smart Drive does not require the use of isolation transformers. However, a transformer may be required to match the voltage requirements of the controller to the available service. To size a transformer for the main AC power inputs, the power output (KVA) of each axis must be known. This can be derived by calculating the horsepower for each axis and converting that horsepower into units of watts. If power is being supplied to more than one motor and a drive, simply add the kW ratings together from each calculation to get a system kW total.

For an autotransformer, ensure that the phase to neutral/ground voltages do not exceed the input voltage ratings of the drive.

If you are using the Motions Solutions Sizing Software, the average speed and average torque data has already been calculated and can be used in the equation. If you are not sure of the exact speed and torque in your application, record the speed/torque curve for your drive/motor combination and use the resulting values as a worst case continuous speed and torque.

Calculations are multiplied by a factor to compensate for the power and loss elements within a power system. A factor of 2.0 is used with a single phase system and a factor of 1.5 is used with a three phase system. This factor should minimize the effects of the secondary line voltage sagging in the transformer during peak current periods.

The speed/torque curve information for 230V motors is based upon a drive input voltage of 230V AC. For a 115V AC input voltage, the maximum speed can be reduced up to one half.

Example single phase Formula:

$$KVA = \frac{Speed(RPM) \cdot Torque(lb - in)}{63,025} \cdot \frac{0.746 \cdot KVA}{HP} \cdot 2.0$$

Example three phase Formula:

$$KVA = \frac{Speed(RPM) \cdot Torque(lb - in)}{63,025} \cdot \frac{0.746 \cdot KVA}{HP} \cdot 1.5$$

NOTE

For 460V drives, the 3-Phase source powering the drive has to be a center-grounded "Y" configuration. Do not exceed 304 Volts RMS from any phase to ground.

For 220V drives, the 3-Phase source powering the drive does not have to be a center-grounded "Y" configuration. Do not exceed 152 Volts RMS from any phase to ground.

4.5 External Shunts

Power from the motor is returned to the MMC Smart Drive during motor deceleration. Excessive power may have to be dissipated from the MMC Smart drive when large inertia loads are present. External shunts should be used to avoid excessive bus over voltage faults.

This section covers three aspects of External Shunts:

- Refer to [section 4.5.1 on page 58](#) for information on choosing External Shunts.
- Refer to [section 4.5.2 on page 61](#) for information on mounting External Shunts
- Refer to [section 4.5.3 on page 66](#) for information on connecting External Shunts

4.5.1 Choosing External Shunts

This section describes how to select the proper External Shunt based on system parameters.

Kollmorgen recommends you use the Motion Solutions Sizing Software to determine the need for and type of external shunt. However, you may perform the following calculations to choose the external shunt for your application.

1. Obtain the Peak Generating Power for the drive in watts (W).
2. Perform the following calculation:

$W \times T = \text{Watts/sec or Joules}$

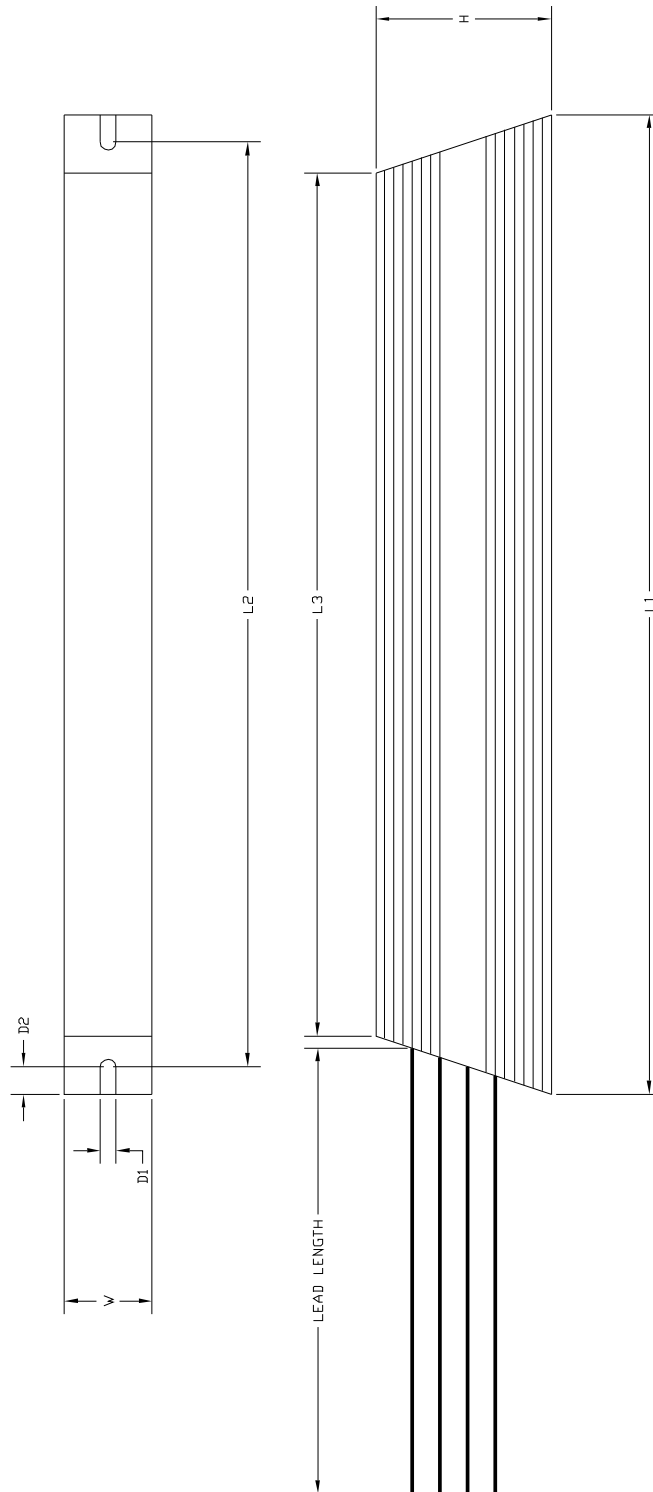

PART NUMBER	DIMENSIONS (mm)							
	L1	L2	L3	W	H	D1	D2	LEADS
M.3000.0503	215	196	175	30	60	5.3	9.5	500
M.3000.1344	215	196	175	30	60	5.3	9.5	500
M.3000.0504	210	197	170	22	41	4.3	6.5	500
M.3000.0505	215	196	175	30	60	5.3	9.5	500
M.3000.0506	335	316	295	30	60	5.3	9.5	500
M.3000.0507	285	266	245	61	59	5.3	9.5	500
M.3000.0508	405	386	365	61	59	5.3	9.5	500

where:

W is watts from Step 1 above,

T is decel time required by the application

3. Obtain the Absorption Energy in Joules for the drive from the Specifications section of the drive manual.
4. Determine the Peak Shunt Power from the drive that would be delivered to the shunt resistor for your application:
 - (Number calculated in Step 2 above) - (Absorption Energy from the drive Specifications table in either Chapter 5 or 6)
= Watt-seconds
 - (Watt-seconds computed in 5a. above) \div (Decel Time for the application) =
Peak Shunt Power in Watts
5. Determine the Continuous Shunt Power that would be delivered to the shunt resistor for this application:
 - Duty Cycle of Peak or Peak x Decel Time) \div (Total Cycle Time) = Continuous Shunt Power in Watts
6. Choose an external shunt from [Table 4-14](#).

Table 4-14: Shunt Resistors		
For Drive ^a	Shunt Resistor Module	Part Number
MMC-SD-0.5-230 MMC-SD-1.0-230 MMC-SD-2.0-230 MMC-SD-3.0-230	For Single Phase Drives: 38Ω, 300W, 600V, Dynamic	M.3000.1346
	For Three Phase Drives: 30Ω, 300W Cont. Power. 215mm(L) x 60mm(W) x 30mm(H)	M.3000.0503
MMC-SD-1.3-460 MMC-SD-2.4-460	145Ω, 450W Cont. Power, 5.4kW Peak Power, 820 V, 240 sec. Time Constant, 121 mm x 93 mm x 605 mm	M.1302.7048
	130Ω, 150W, Reduced Size Panel Mount	M.3000.0504
MMC-SD-4.0-460	95Ω, 700W Cont. Power, 8kW Peak Power, 820 V, 250 sec. Time Constant, 121 mm x 93 mm x 705 mm	M.1302.7049
	95Ω, 300W, Reduced Size Panel Mount	M.3000.0505
MMC-SD-6.0-460 MMC-SD-8.0-460	50Ω, 1400W Cont. Power, 17kW Peak Power, 850V, 250 sec. Time Constant, 130 mm x 182 mm x 710 mm	M.1302.7060
	50Ω, 500W, Reduced Size Panel Mount	M.3000.0506
MMC-SD-12.0-460 MMC-SD-16.0-460	25Ω, 2800W Cont. Power, 32kW Peak Power, 850V, 60 sec. Time Constant, 171 mm x 430 mm x 550 mm	M.1302.7061
	25Ω, 800W, Reduced Size Panel Mount	M.3000.0507
MMC-SD-24.0-460 MMC-SD-30.0-460 MMC-SD-42.0-460 MMC-SD-51.0-460 MMC-SD-65.0-460	18Ω, 3900W Cont. Power, 70kW Peak Power, 850V, 70 sec. Time Constant, 180 mm x 445 mm x 490 mm	M.1302.7063
	18Ω, 1200W, Reduced Size Panel Mount	M.3000.0508
MMC-SDN-XXX	See section 6.2.4.2 on page 149 for information on shunt (regen) resistors for use with the SDN drives	

a. Drive Model pertains to Analog (no dash suffix) and digital (-D)

4.5.2 Mounting External Shunts

This section describes the mounting requirements for External Shunts available from Kollmorgen.

**EXTERNAL SHUNTS ON SMART DRIVE NEXTGEN (SDN)
DRIVES**

For a detailed description of shunts these shunts, refer to the Kollmorgen "AKD/S700 Accessories Manual" which can be found at www.kollmorgen.com.

Figure 4-2: Mounting Dimensions for 230V Active Shunt Kit (P/N M.3000.1346)

Figure 4-3: Mounting Dimensions for 460V External Shunt (P/N M.1302.7048)

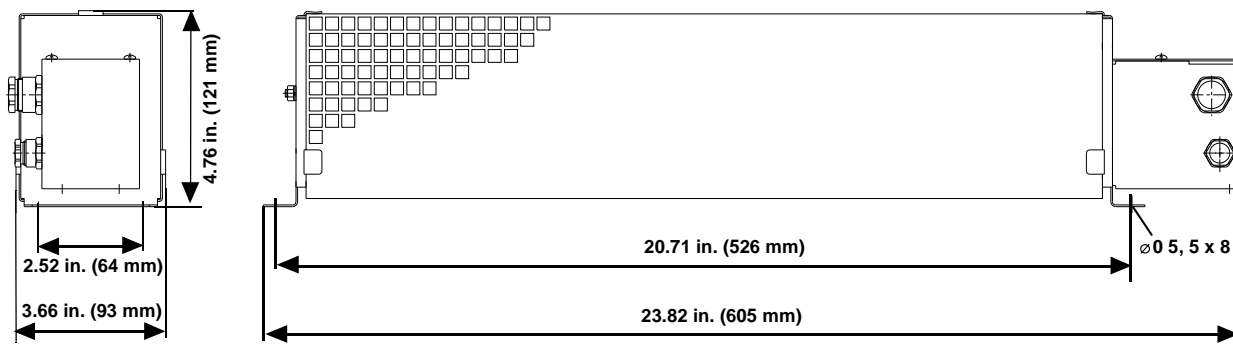

Figure 4-4: Mounting Dimensions for 460V External Shunt (P/N M.1302.7049)

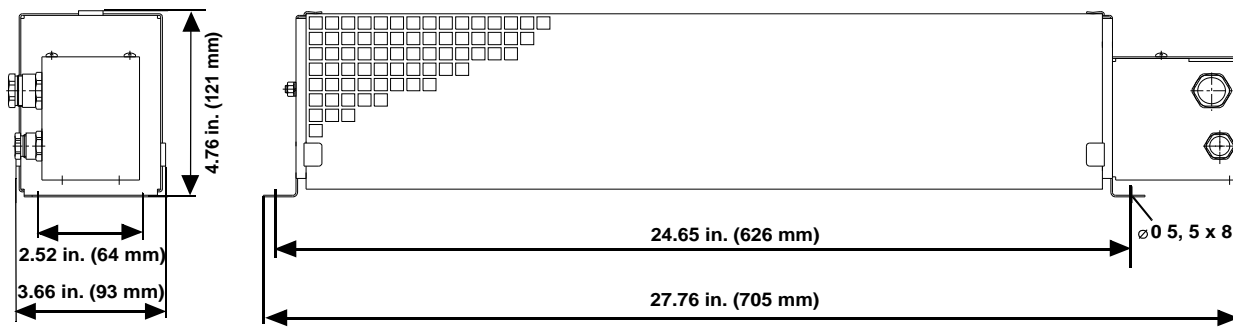

Figure 4-5: Mounting Dimensions for 460V External Shunt (P/N M.1302.7060)

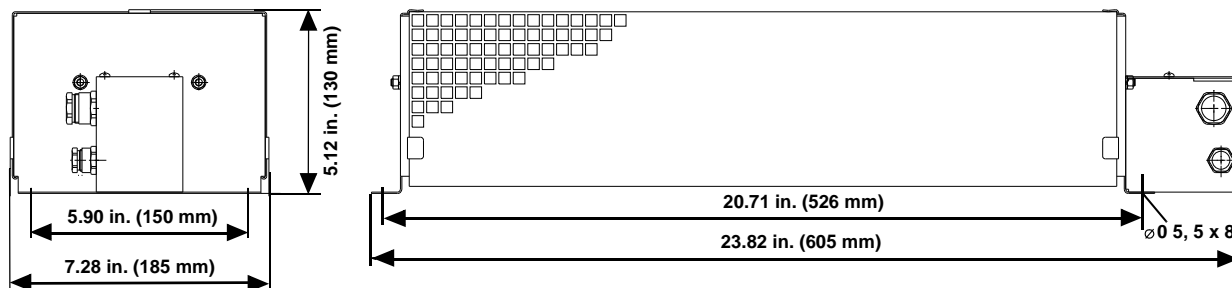

Figure 4-6: Mounting Dimensions for 460V External Shunt (P/N M.1302.7061)

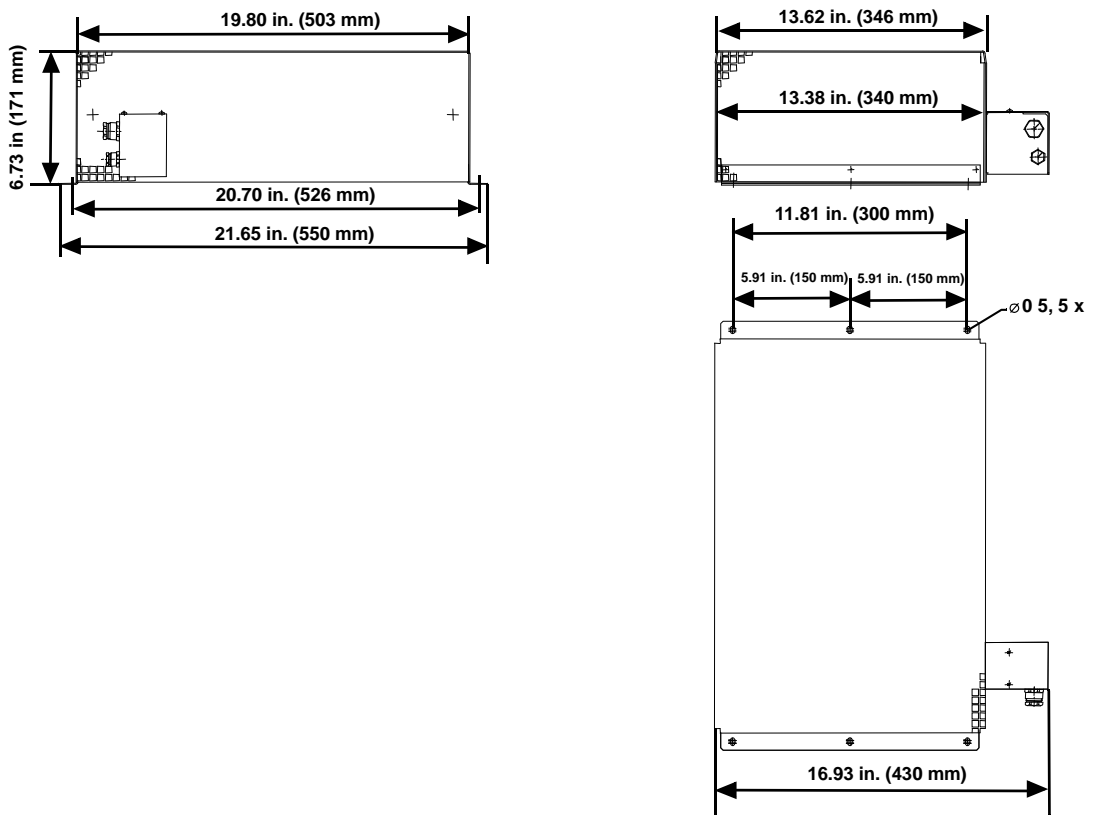

Figure 4-7: Mounting Dimensions for 460V External Shunt (P/N M.1302.7063)

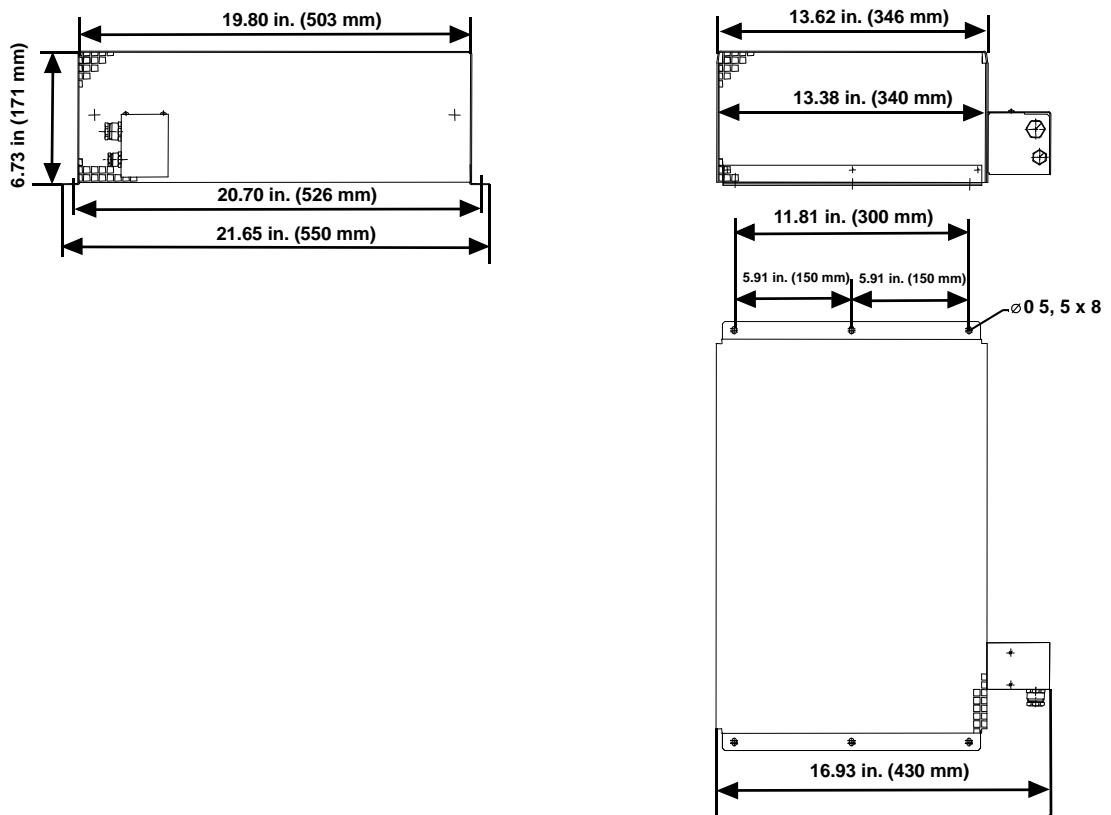

Figure 4-8: Mounting Dimensions for Reduced Size Panel mount Shunts**4.5.3 Connecting Shunt Modules**

This section describes how to connect External Shunts to the drive.

Use shielded, high temperature 75° C (167° F), 600V, 2.5-4.0 mm² (12-14 AWG), 3.05 m (10 ft) maximum, copper wire. Follow one of the methods given below to reduce the effects of EMI noise:

- Install wires using twisted pairs (two turns per foot minimum), as shown in the figure below. Keep unshielded wires as short as possible.
- Use shielded, twisted cable (ground shield at shunt and drive).
- Use shielded metal conduit (ground conduit at shunt and drive).

When two shunt modules are connected in parallel, the shunt capacity is doubled.

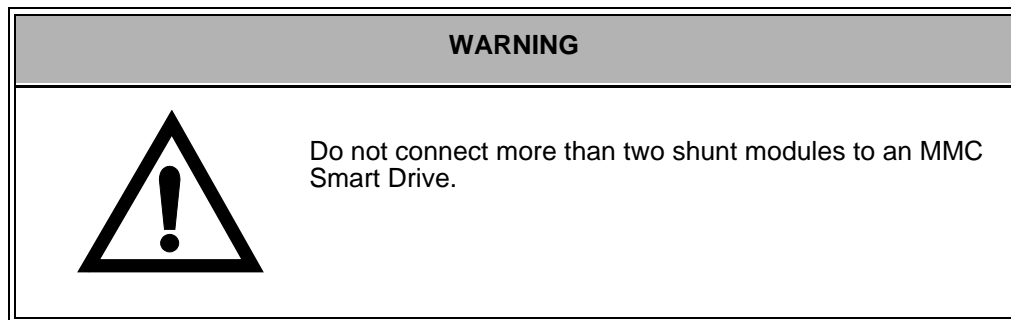
**4.5.3.1 230V, 1-Phase MMC Smart Drive Shunt Wiring**

The 230V, 1-Phase MMC Smart Drive requires the use of an Active Shunt module. Refer to [Figure 4-9](#) for wiring an Active Shunt Module to this drive.

The 230V, 3-Phase MMC Smart Drive requires the use of a Passive Shunt module (regen resistor). Refer to [Figure 4-10](#) for wiring an Passive Shunt Module to this drive.

Figure 4-9: 230V, 1-Phase MMC Smart Drive Shunt Wiring

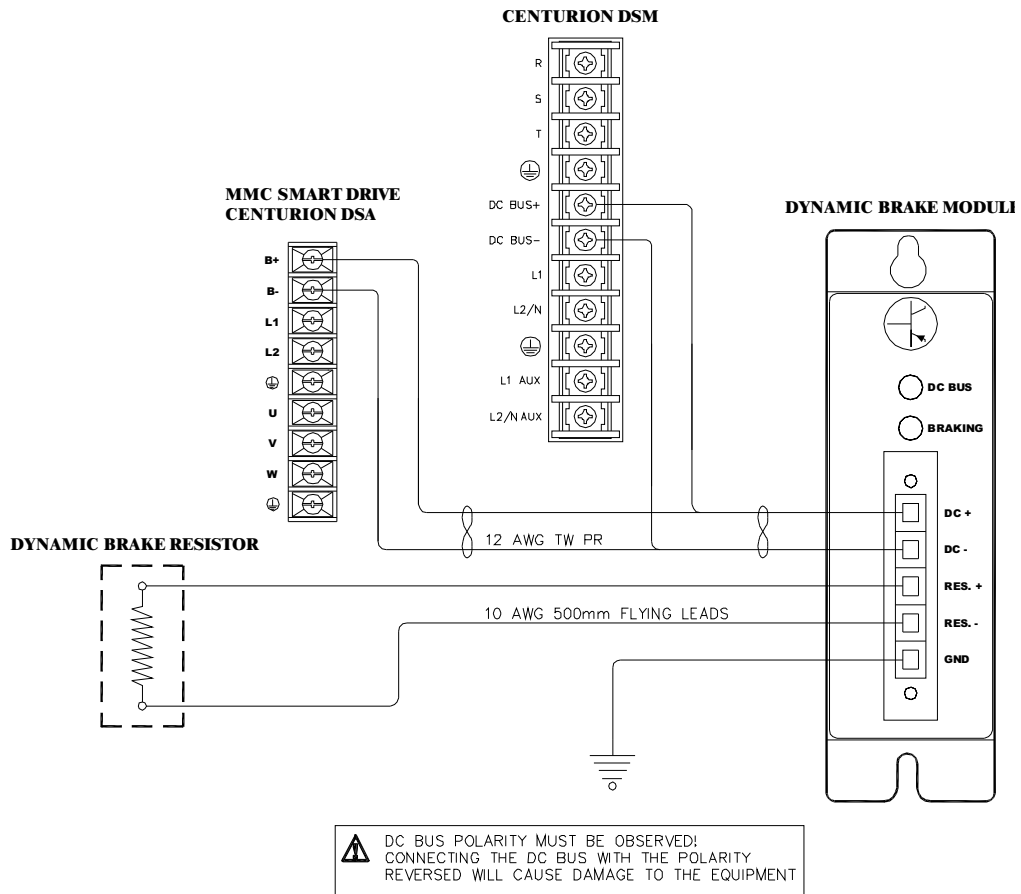
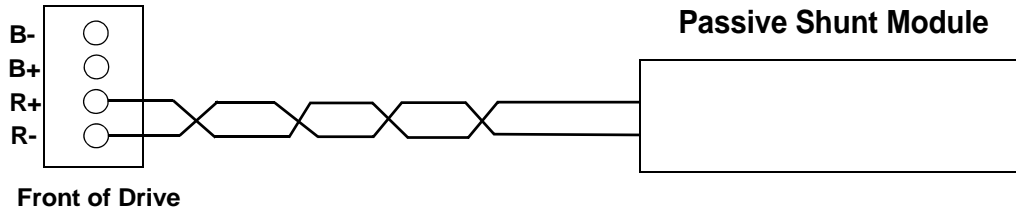

Figure 4-10: 230V, 3-Phase MMC Smart Drive Shunt Wiring

**230V MMC Smart Drive
Bus/Regen Connector
(located on bottom of drive)**



4.5.3.2 460V, 3-Phase MMC Smart Drive (-SD) Shunt Wiring

The 460V, 3-Phase MMC Smart Drive requires the use of a Passive Shunt module (regen resistor). Refer to [Figure 4-11](#) for wiring an Passive Shunt Module to this drive.

Figure 4-11: 460V, 3-Phase MMC Smart Drive (-SD) Shunt Wiring

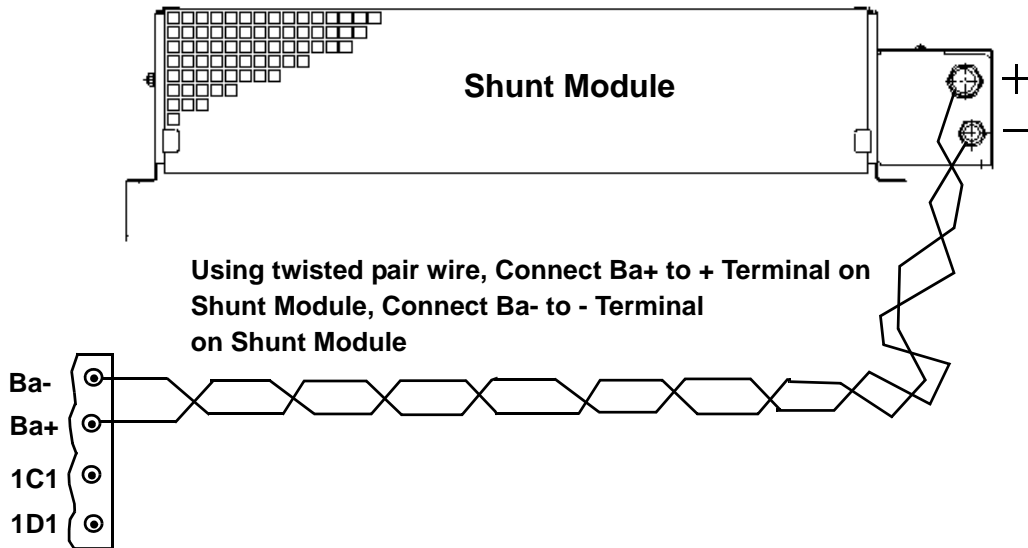

**460V MMC Smart Drive
Shunt/DC Bus Terminal Strip**

4.6 Line Filters

Line Filters consist of combinations of capacitors, reactors, resistors and voltage limiters that are intended to reduce the electromagnetic influence of the environment.

LINE FILTERS ON SMART DRIVE NEXTGEN (SDN) DRIVES
MMC-SDN-XXXX drives do not require line filters

4.6.1 Line Filters and CE Compliance

The direction of influence is bi-directional, i.e. there is a reaction in the units of emission of conducted disturbances, and, at the same time, an improvement in the immunity of the drive to interference that occurs in the case of lightning strikes, tripped fuses, or simple switching activities.

- The filter should be mounted to a grounded conductive surface.
- The filter must be mounted close to the drive input terminals. If the distance exceeds 2 feet (600 mm), then a shielded cable should be used to connect the drive and filter, rather than a wire.
- The wires connecting the AC source to the filter should be shielded from, or at least separated from the wires (or strap) connecting the drive to the filter. If the connections are not segregated from each other, then the EMI on the drive side of the filter can couple over to the source side of the filter, thereby reducing, or eliminating the filter effectiveness. The coupling mechanism can be radiation, or stray capacitance between the wires.

Figure 4-12: Block Diagram Simplified for 3-Phase Line Filter

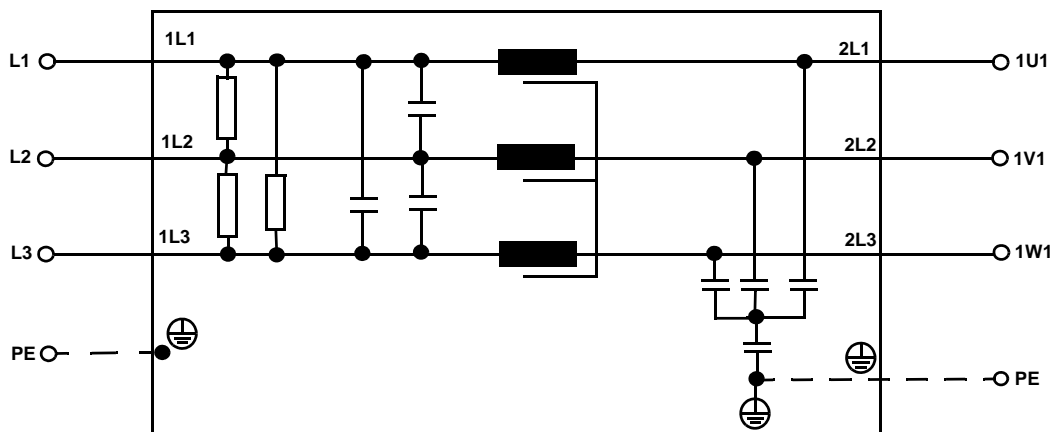
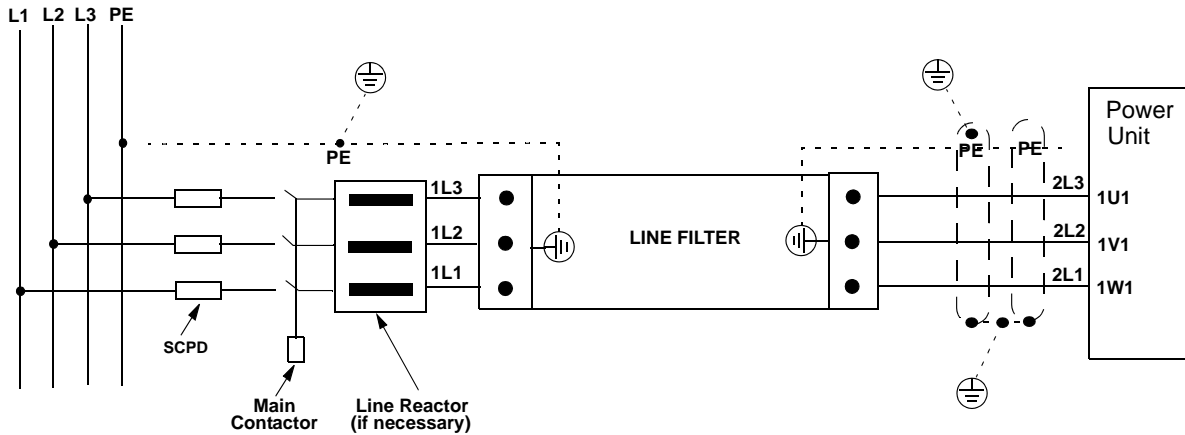



Figure 4-13: Connection Diagram for 3-Phase Line Filter



WARNING	
	<p>High leakage currents exist in AC line filters. The filters must be grounded properly before applying power. Filter capacitors retain high voltages after removal. Measure voltages to determine safe levels prior to handling the equipment. Failure to do so could result in severe bodily injury.</p>

NOTE
<p>To be able to route the interference currents at low impedance back to the interference sources, the filter, the power unit, and the contact area of the motor cable shield must have a junction with the common mounting plate over as wide a surface as possible that has good conductive properties. The best way to ensure this is to use unpainted zinc-coated mounting plates.</p>

Current	For Drive	Part Number
6A, 250V, 1 Phase	Single Phase Versions of: MMC-SD-0.5-230 MMC-SD-1.0-230	M.1015.6922

Table 4-15: Part Numbers for AC Line Filters		
Current	For Drive	Part Number
10A, 250V, 1 Phase	Single Phase Versions of: MMC-SD-2.0-230 MMC-SD-3.0-230	M.1015.6917
16A, 480V, 3 Phase	Three Phase Versions of: MMC-SD-0.5-230 MMC-SD-1.0-230 MMC-SD-2.0-230 MMC-SD-3.0-230	M.1302.5244
7A, 480V, 3 Phase	MMC-SD-1.3-460 MMC-SD-2.4-460	M.1302.5241
16A, 480V, 3 Phase	MMC-SD-4.0-460 MMC-SD-6.0-460 MMC-SD-8.0-460	M.1302.5244
30A, 480V, 3 Phase	MMC-SD-12.0-460 MMC-SD-16.0-460	M.1302.5245
42A, 480V, 3 Phase	MMC-SD-24.0-460	M.1302.5246
56A, 480V, 3 Phase	MMC-SD-30.0-460 MMC-SD-42.0-460	M.1302.5247
75A, 480V, 3 Phase	MMC-SD-51.0-460	M.1302.5248
100A, 480V, 3 Phase	MMC-SD-65.0-460	M.3000.0109

Table 4-16: Technical Data for 230V Line Filters			
	M.1015.6922	M.1015.6917	M.1015.6918
Voltage/Freq.	250VAC @ 50/50Hz	250VAC @ 50/50Hz	250VAC @ 50/50Hz
Current	6A @ 50°C	10A @ 50°C	23A @ 50°C
Overload Current	150% 1 minute 200% 1 second	150% 1 minute 200% 1 second	150% 1 minute 200% 1 second
Temperature	-25 to 95°C	-25 to 95°C	-25 to 95°C
Leakage Current	5mA @ 240V, 50 Hz	46mA @ 240V, 50 Hz	200mA @ 250V, 50Hz
Electric Strength	2500VAC/1 minute	2500VAC/1 minute	2500VAC/1 minute
Power Loss	3.5W (Full Load)	2.7W (Full Load)	10W (Full Load)
Terminals	2mm sq. spring clamp	M4 screw cross/ sq. 2x 2.5mm	M4 screw cross/ sq. 2x 2.5mm
Weight	0.3Kg (0.66 Lb.)	0.95Kg (2.0 Lb)	1.6Kg (2.5 Lb)
Back Mounting ^a	4 x M4	4 x M4	4 x M4
Side Mounting ^a	2 x M5	2 x M6	2 x M6

a. Line filters are manufactured to millimeter dimensions (inches are approximate conversions).

Table 4-17: Technical Data for 460V Line Filters							
Item	Part Number						
	M.1302.5241	M.1302.5244	M.1302.5245	M.1302.5246	M.1302.5247	M.1302.5248	M.3000.0109
Maximum Supply Voltage	3 x 480VAC, 50/60Hz						
Rated current (at 40°C)	7A	16A	30A	42A	56A	75A	100A
Peak current	1.5 x I _N for < 1 min. per hour at T _B = 40°						
Test Voltage Phase/Phase Phase/Ground	2.1 kVDC for 2 sec. at 25°C 2.7 kVDC for 2 sec. at 25°C						
Maximum Connection Cross-section	4mm ²	4mm ²	10mm ²	10mm ²	4mm ²	25mm ²	50mm ²
Operational Environmental Temperature Range T _B	-25°C ... +55°C Reduction of rated current from 40°C onwards by 1.4% / °C						
Power Loss (typical)	4W	8W	12W	15W	18W	24W	24W
Site Altitude	Below 2000 m above sea level (higher altitudes on request)						
Storage Temperature Range	-25°C ... +85°C						
Type of Protection	IP20						
Weight	0.6kg	1.0kg	1.3kg	1.6kg	1.9kg	2.6kg	4.0kg

4.6.2 Dimensions for 230V Line Filters

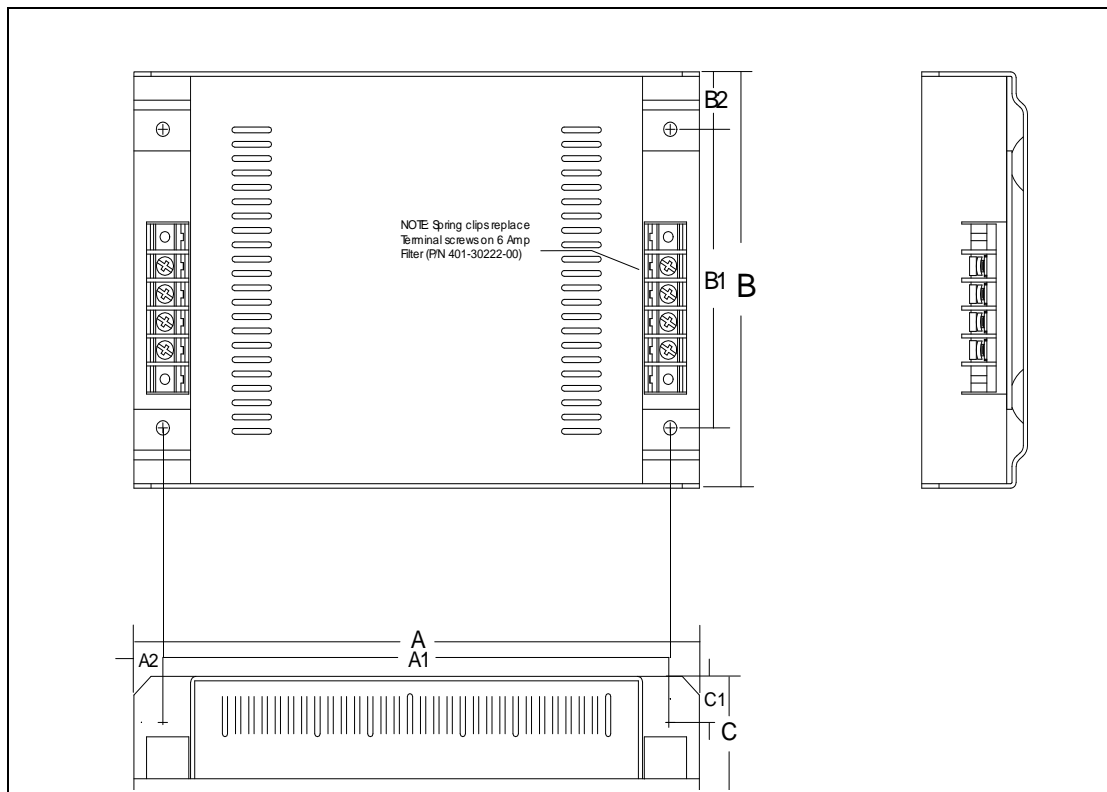

MEASUREMENT	SINGLE PHASE 6A M.1015.6922		SINGLE PHASE 10A M.1015.6917		SINGLE PHASE 23A M.1015.6918	
	mm	in	mm	in	mm	in
A	170	6.7	214	8.4	214	8.4
A1	152	6.0	192	7.6	192	7.6
A2	9	0.4	11	0.4	11	0.4
B	92	3.6	145	5.7	204	8.0
B1	55	2.2	104	4.1	164	6.6
B2	18	0.7	20	0.8	20	0.8
C	25	1.0	40	1.6	47	1.8
C1	10	0.4	16	0.6	19	0.8

4.6.3 Dimensions for 460V Line Filters

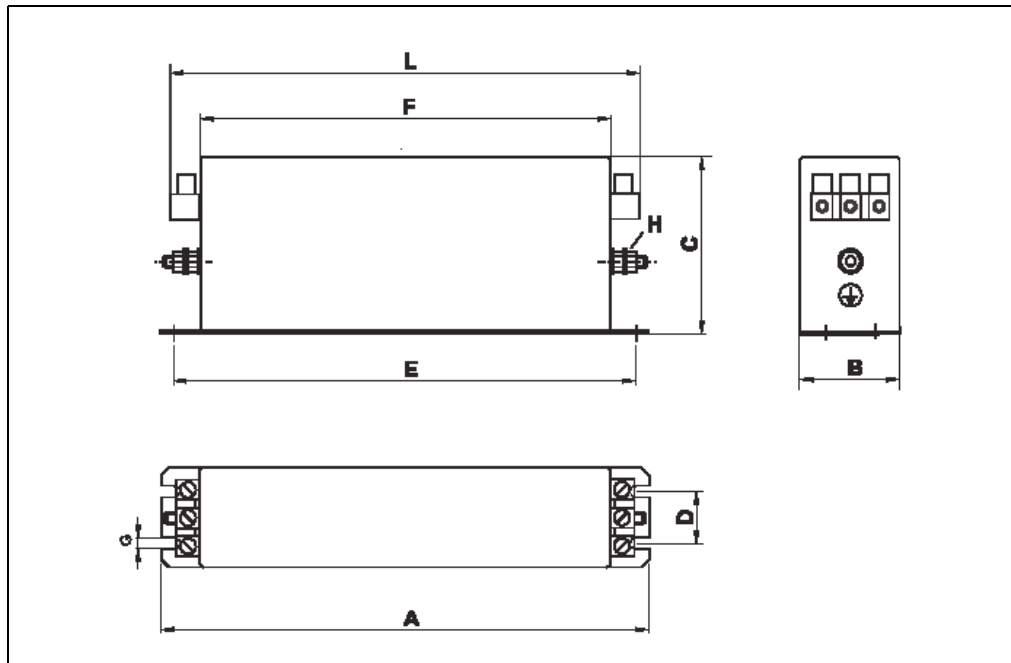

Part Number	A	B	C	D	E	F	L	G	H
M.1302.5241	190	40	70	20	180	160	185	5.4	M5
M.1302.5244	250	50	70	25	235	220	245		
M.1302.5245	270	50	85	30	255	240	265		
M.1302.5246	310	50	85	30	295	280	305		
M.1302.5247	250	85	90	60	235	220	258	6.5	M6
M.1302.5248	270	80	135	60	255	240	278		
M.3000.0190	270	90	150	65	255	240	326	6.5	M10

5 230V 3 Phase MMC Smart Drive NextGen

The 230V Smart Drive NextGen (the Drive) is an AC Servo Drive capable of driving a wide range of Brush-type and Brushless DC motors.

The Drives' Power Section features the following:

- May be connected to a wide range of Mains power:
 - 100-240VAC, 50/60Hz, 1 or 3 phase
- Built-in regen resistor (12A and 24A models only)
 - Supports external regen resistors if required by application
- Brake Output (this can also be used as a General Purpose Output)
- Supports DC bus sharing
- Safe Torque Off capability

The Drive's Control Section features the following:

- Connects to Kollmorgen's Digital Link bus
- Two-digit error/status display
- A primary feedback connector (F1), containing the following features:
 - High density female DB-15 connector
 - Supports the following feedback devices:
 - Incremental Encoder (without halls)
 - Stegmann Hiperface encoder
 - High Resolution Resolver
 - 1V p-p Sinewave Encoder
 - Endat 2.1 (2.2 in future release)
 - BiSS (Mode B)
 - SFD (Smart Feedback Device). Note: An SFD can be connected to F1 or F2, not both
- A secondary feedback connector (F2), containing the following features:
 - High density female DB-15 connector
 - This connector can support one of the following functions:
 - Emulated F1 encoder output
 - Comcoder Input (Incremental Encoder with halls)
 - SFD Input (Smart Feedback Device). Note: An SFD can be connected to F1 or F2, not both.
- I/O connectors, containing the following features:
 - Two pluggable 10-pin screw-terminal connectors
 - Two Fast DC Inputs (sink or source in group of two)

- Six General Purpose DC Inputs (sink or source in group of six)
- Two General Purpose DC Outputs (sourcing)
- Analog Input
- Analog Output
- Relay Output

Figure 5-1: Front Panel, SDN Drives

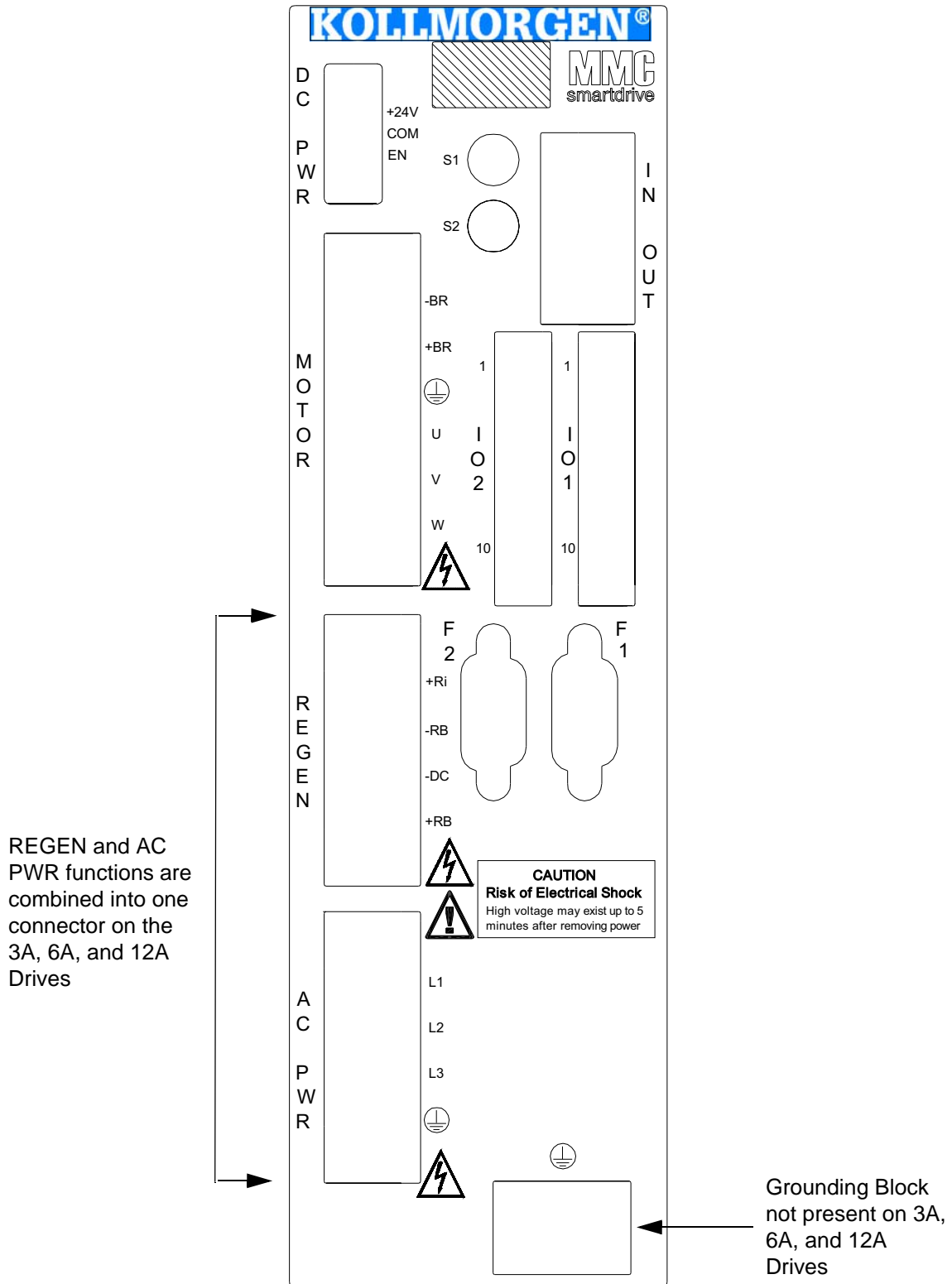

5.1 Control Section Connectors, Switches, LEDs

This section describes the connectors, switches, and LEDs located on the Control Section (right portion) of the drive.

5.1.1 Status Display

The Status Display is located on the top-front of the drive, and consists of two 7-segment displays. The Status Display will indicate the Drive's current operating condition, including error codes. Refer to the PiCPro Help for the description of the various display conditions.

5.1.2 Node Address Rotary Switches

Two rotary switches are used to set the drive address. Rotate the switch to the desired address.

Addresses can be set to any number from 1 through 64. The top switch (S1) represents values of base ten. The bottom switch (S2) represents values of base 1.

As an example, rotating S1 to a setting of 2 equals the value of 20 (2 x 10). Rotating S2 to a setting of 5 equals the value of 5. The actual address setting is 25 (20 + 5).

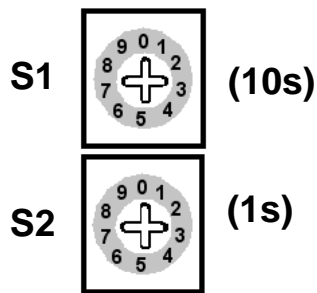

5.1.3 Digital Link Ports

The two 8-pin RJ-45 Digital Link Port connectors (labeled "IN" and "OUT" on the front of the Drive) provide communications between the Drive and other Digital Link devices (another Digital Drive, a Standalone MMC Digital Control, Slice I/O Coupler, DL-DIU, etc.). There is a green "Link" light located in the upper-right corner of each connector. If this light is on, another Digital Link device is properly connected to the associated "IN" or "OUT" port.

A "straight-through" shielded cable must be used when connecting the Drive to other Digital Link devices. Connect a cable from another Digital Link device's "OUT" port to the Drive's "IN" port, and another cable from the Drive's "OUT" port to the next Digital Link device's "IN" port.

- Pin descriptions for are provided in [Table 5-1](#)
- Pin assignments are provided in [Table 5-2](#)
- The available Digital Link Port to Digital Drive cables are described in [Table 5-3](#)

Digital Link Connector (IN/OUT) Signals		Pin	
Function	Notes	"In" Connector	"Out" Connector
Receive Data +	Receives data from connected drives.	1	3
Receive Data -	Receives data from connected drives.	2	6
Transmit Data +	Transmits data to connected drives.	3	1
Transmit Data -	Transmits data to connected drives.	6	2
Protective Ground	Provides a path for the ground signal to an external single point ground.	Connector Shell	Connector Shell

Table 5-2: Digital Link Port Pin Assignments

Pin	Label	In/Out	Connector Pinout
IN Connector			<p>RJ-45 Connectors</p>
1	Receive +	In	
2	Receive -	In	
3	Transmit +	Out	
4	Not Used	N/A	
5	Not Used	N/A	
6	Transmit -	Out	
7	Not Used	N/A	
8	Not Used	N/A	
Connector Shield	Provides a path for the ground signal to an external single point ground.	In	
OUT Connector			
1	Transmit +	Out	
2	Transmit -	Out	
3	Receive +	In	
4	Not Used	N/A	
5	Not Used	N/A	
6	Receive -	In	
7	Not Used	N/A	
8	Not Used	N/A	
Connector Shield	Provides a path for the ground signal to an external single point ground.	In	

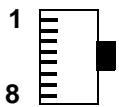
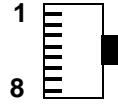
Table 5-3: Digital Link Port “IN” to “OUT” Cables				
Part Numbers: .3 M (1.0 ft): M.1302.8285 .6 M (2.0 ft): M.1302.8286 1 M (3.3 ft): M.1302.8287 2 M (6.6 ft): M.1302.8288 3 M (9.8 ft): M.1302.8289 5 M (16.4 ft): M.1302.8300 10 M (32.8 ft): M.1302.8301 15 M (49.2 ft): M.1302.8302 30 M (98.4 ft): M.1302.8303 Cable type: 28 AWG, shielded, twisted pair, 8 conductor.				
8-Pin RJ-45 Plug (to Digital Link Port “OUT”, face view) 		8-Pin RJ-45 Plug (to Digital Drive “IN”, face view) 		
Pin	Signal	Pin	Signal	Notes
1	Transmit Data +	1	Receive Data +	Twisted
2	Transmit Data -	2	Receive Data -	Pair
3	Receive Data +	3	Transmit Data +	Twisted
6	Receive Data -	6	Transmit Data -	Pair
4	None	4	None	Twisted
5	None	5	None	Pair
7	None	7	None	Twisted
8	None	8	None	Pair
Shell	Drain	Shell	Drain	

5.1.4 Feedback Connectors (F1 & F2)

The two 15-pin female Feedback connectors (labeled “F1” and “F2” on the front of the Drive) provide an interface between two feedback devices. A detailed description of the capabilities and limitations of connected devices can be found in [section 5.1.4.1 on page 88](#).

- Pin descriptions for the F1 connector are provided in [Table 5-4](#)
- Pin assignments for the F1 connector are provided in [Table 5-5](#)
- Pin descriptions for the F2 connector are provided in [Table 5-6](#)
- Pin assignments for the F2 connector are provided in [Table 5-7](#)
- The available Flying Lead cable is described in [Table 5-9](#).
- Available Breakout Boxes and Cables are described in [Table 5-10](#).
- Breakout Box dimensions are shown in [Figure 5-2](#)
- Breakout Board dimensions are shown in [Figure 5-3](#)
- Feedback Port to Motor Cables are described in [section 5.1.4.2 on page 93](#)

Table 5-4: Pin Description for Feedback Connector (F1)

F1 Feedback Signals			
Signal Type	Signal Name	Notes	Pin
Incremental Encoder Inputs	A1, A1/, B1, B1/, I1, I1/	Differential A quad B encoder signals.	12, 13, 14, 15, 6, 7
Sinewave Encoder Inputs	Sin, Sin/, Cos, Cos/	Sinewave Encoder signals	12, 13, 14, 15
Sinewave Encoder Data Channel In/Out	RS-485 Data +, RS-485 Data -, RS-485 Clock+, RS-485 Clock-	RS-485 signals for connecting the Sinewave Encoder Data Channel to the drive	6, 7, 2, 3
SFD Communication Channel	Com+, Com-	SFD communication signals. An SFD can be connected to F1 or F2, not both	6, 7
Resolver Inputs	Sin+, Sin-, Cos+, Cos-	Resolver stator feedback signals	12, 13, 14, 15
Resolver Outputs	Carrier+, Carrier-	Resolver rotor excitation signals.	6, 7
Temperature Input	Temperature	Thermostat (normally- closed) or Thermistor (Phillips KTY84-130 PTC or equivalent recommended) input for detecting over temperature conditions within the motor. These inputs are shared with F2.	8, 9
+5V Encoder Power Outputs	+5V Source	Regulated +5VDC for powering the attached encoder (350ma max).	10
+5V Encoder Power Sense Lines	+5V Sense+, +5V Sense-	These signals should be tied to the +5V power and ground lines at the encoder.	4, 5
Signal and Power Common	Common	Return path for feedback signals and +5V power output	11

PROVIDING 8VDC ENCODER POWER

Some Encoders, specifically the Stegmann Hiperface, require 8VDC power to operate. 8VDC Power can be provided on pins 10 and 11 by connecting the +5V Sense Lines (pins 4 & 5) together.

Table 5-5: Pin Assignments for Feedback Connector (F1)

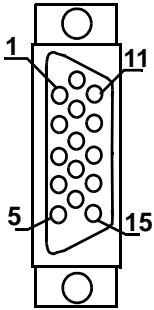
Pin	Feedback Device							In/ Out	Connector Pinout
	Digital Incremental Encoder	Sinewave Encoder		BISS ^a	1V p-p Sine Wave	SFD ^b	Resolver		
		Hiper- face ^c	Endat ^d						
1	N/U (Not Used)								15-pin Female HD D-Sub 
2	N/U	RS-485 Clock+		N/U			Out		
3	N/U	RS-485 Clock-		N/U					
4	+5V Sense+ ^e					N/U		In	
5	+5V Sense- ^e					N/U			
6	I1	RS-485 Data+		N/U	Com+	Carrier+	Note ^f		
7	I1/	RS-485 Data-		N/U	Com-	Carrier-			
8	Temperature+ ^g							In	
9	Temperature- ^g								
10	+5V Source	+8V ^h	+5V Source			N/U		Out	
11	Common					N/U		In/Out	
12	A1	Sine	N/U	Sine	N/U	Sin+	In		
13	A1/	Sine/	N/U	Sine/	N/U	Sin-			
14	B1	Cos	N/U	Cos	N/U	Cos+			
15	B1/	Cos/	N/U	Cos/	N/U	Cos-			
Shell	Shield							N/A	

- a. Supports BiSS Mode B (digital)
- b. An SFD can be connected to F1 or F2, not both
- c. Stegmann Hiperface
- d. Supports Endat 1.1 (Support for Endat 2.1 & 2.2 in future release)
- e. Use of Sense Lines is optional, except if connecting to a Hiperface encoder (see footnote ^h, below)
- f. Pins 6 and 7 are In/Out for Hiperface, Endat, and SFD; Inputs for Digital Incremental and BiSS; and Outputs for Resolver
- g. Temperature inputs (pins 8 and 9) are shared with the F2 connector
- h. Hiperface requires +8Vdc. To supply +8V from pin 10, connect +5V Sense lines (pins 4 & 5) together.

Table 5-6: Pin Description for Feedback Connector (F2)

Signal Type	Signal Name	Notes	Pin
Incremental Encoder Inputs	A1, A1/, B1, B1/, I1, I1/	Differential A quad B encoder signals. These can be defined as inputs or outputs in PiCPro.	12, 13, 14, 15, 6, 7
Emulated F1 Encoder Output	A1, A1/, B1, B1/, I1, I1/	RS485 drivers are used and the signal that is output depends on the encoder or resolver type used. See specifications in section 5.3 on page 109 of this manual. These signals are generated after the feedback from the F1 connector is filtered and processed. These can be defined as inputs or outputs in PiCPro.	12, 13, 14, 15, 6, 7
Motor Commutation Hall Sensor Inputs	S1, S2, S3	Hall-device input signals that are used to initialize the motor commutation angle. They consist of a 74HC14 input with a 10 μ s filter and a 2.2K pull-up to +5V. Shared with F1.	1, 2, 3
SFD Communication Channel	Com+, Com-	SFD communication signals. An SFD can be connected to F1 or F2, not both. An SFD Device can only be connected to F2 if emulated F1 encoder is not used (in which case emulated I and I/ are output on F2 pins 6 & 7).	6, 7
Temperature Input	Temperature	Thermostat (normally- closed) or Thermistor (Phillips KTY84-130 PTC or equivalent recommended) input for detecting over temperature conditions within the motor. These inputs are shared with F1.	8, 9
+5V Encoder Power Output	+5V Source	Regulated +5VDC for powering the attached encoder (200ma max).	10
Signal and Power Common	Common	Return path for feedback signals and +5V power output	11

Table 5-7: Pin Assignments for Feedback Connector (F2)

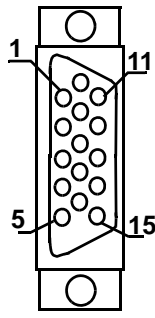
Pin	Signal Name	In/Out	Connector Pinout
1	S1	In	<p>15-pin Female HD D-Sub</p> 
2	S2	In	
3	S3	In	
4	N/U		
5	N/U		
6	I2 (Encoder) Com+ (SFD ^a)	In/Out ^b	
7	I2/ (Encoder) Com- (SFD ^a)	In/Out ^b	
8	Temperature+	In	
9	Temperature-	N/A	
10	+5V	Out	
11	0V	Out	
12	A2	In/Out ^c	
13	A2/	In/Out ^c	
14	B2	In/Out ^c	
15	B2/	In/Out ^c	
Shell	Shield	In	

- a. An SFD can be connected to F1 or F2, not both. An SFD Device can only be connected to F2 if emulated F1 encoder is not used (in which case emulated I and I/ are output on F2 pins 6 & 7).
- b. This pin is an Input when F2 is configured for Encoder Input, an Output when F2 is configured for Emulated Encoder Output, and an Input/Output when F2 is configured for SFD.
- c. This pin is an Input when F2 is configured for Encoder Input, and an Output when F2 is configured for Emulated Encoder Output.

5.1.4.1 Feedback Connectors (F1 and F2) Details

The F1 and F2 Feedback connectors support a variety of devices and functions. This section helps clarify the capabilities and limitations of connected devices.

- The Temperature Inputs are bussed internally between the two feedback connectors F1 and F2. A temperature sensing device can be connected to F1 or F2, but not both.
- Either F1 or F2 can be designated (in PiCPro) as the motor feedback connector.
- F1 can be interfaced to an incremental encoder, sinewave encoder, resolver, or SFD encoder. The signals from the F1 connector are conditioned and can be routed to the F2 connector.
- In PiCPro, the F2 connector can be configured in one of the following modes:
 - To accept Encoder Inputs
 - To provide conditioned Emulated Encoder Outputs derived from the F1 encoder signals
 - To accept SFD feedback device signals
- Hall sensor inputs are only available on the F2 connector
- Refer to [Table 5-8](#) for more information regarding the valid combinations of feedback on the F1 and F2 connectors.

Table 5-8: Supported Feedback Combinations	
Drive Feedback Configuration 1 and 4 (in PiCPro Drive Setup)	
F1 (Motor mounted feedback device for motor control)	F2 (Externally mounted feedback device for position feedback)
<ul style="list-style-type: none"> • Incremental Encoder • Resolver • 1V p-p Sinewave Encoder • Endat 2.1 (single or multi-turn) • Stegmann Hiperface (single or multi-turn) • BiSS (single or multi-turn) • SFD 	<ul style="list-style-type: none"> • Incremental Encoder^a
Drive Feedback Configuration 2 and 3 (in PiCPro Drive Setup)	
F1 (Externally mounted feedback device for position feedback)	F2 (Motor mounted feedback device for motor control)
<ul style="list-style-type: none"> • Incremental Encoder^a • Resolver • 1V p-p Sinewave Encoder • Endat 2.1 (single or multi-turn) • Stegmann Hiperface (single or multi-turn) • BiSS (single or multi-turn) 	<ul style="list-style-type: none"> • Incremental Encoder with halls (Comcoder)^a • SFD

a. The F2 connector can support an Encoder input or Emulated F1 Encoder Output, but not both

Table 5-9: Feedback Port (F1 and F2) to Flying Lead Cable

1 M (3.3 ft): M.3000.1334 3 M (9.8 ft): M.3000.1335
 6 M (19.7 ft): M.3000.1336 9 M (29.5 ft): M.3000.1337
 Cable type: 28 AWG, (1 pair 16 AWG) shielded, twisted pair, 16 conductor.

15-Pin HD male D-sub (to F1/F2 Port, face view)

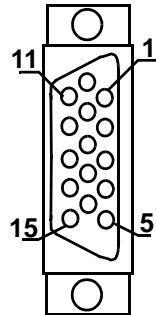

Pin	Signal	Color	Notes
1	S1 ^a	Yellow	Twisted
N/C	N/A	White/Yellow	Pair
2	S2 ^a , RS-485 Clock+	Brown	Twisted
3	S3 ^a , RS-485 Clock-	White/Brown	Pair
4	+5V Sense+	Violet	Twisted
5	+5V Sense-	White/Violet	Pair
6	RS-485 Data+, Com+, Carrier+	Black	Twisted
7	RS-485 Data-, Com-, Carrier-	White/Black	Pair
8	Temperature+	Red	Twisted
9	Temperature-	White/Red	Pair
10	+5V Source	Gray	Twisted
11	Common	White/Gray	Pair ^b
12	Sine/Sin+	Green	Twisted
13	Sine/, Sin-	White/Green	Pair
14	Cos, Cos+	Orange	Twisted
15	Cos/, Cos-	White/Orange	Pair
Shell	Shield	N/A	

a. Hall signals S1, S2, and S3 are only available on F2

b. Pins 10 & 11 are 16 AWG

Description	Length	Part Number
Drive F1/F2 Port Breakout Board ^a	N/A	M.1302.6970
Drive F1/F2 Port Breakout Box ^b	N/A	M.1302.6972
MMC-SDN F1/F2 Port to Breakout Box Cable	1 M (3.3 ft)	M.3000.1330
	3 M (9.8 ft)	M.3000.1331
	6 M (19.7 ft)	M.3000.1332
	9 M (29.5 ft)	M.3000.1333

- a. The Breakout Board (see [Figure 5-3 on page 92](#)) is mounted directly to the F1 and/or F2 connector, and provides screw terminal wire termination. Any combination of breakout board and feedback cable can be used on F1/F2, except a feedback cable on F1 and a breakout board on F2.
- b. The Breakout Box (see [Figure 5-2 on page 92](#)) is DIN-rail mounted, and provides screw terminal wire termination. Use one of the cables listed in the table to connect between the F1 and/or F2 connector and the Breakout Box.

Figure 5-2: Feedback Port (F1 and F2) Breakout Box Dimensions

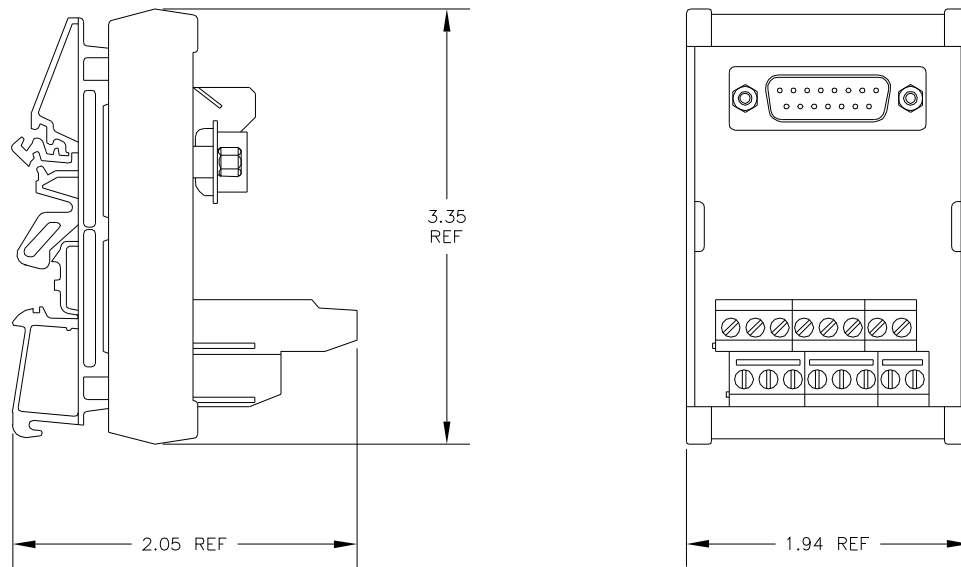

D15 SUB/P
PART NO. M.1302.6972

Figure 5-3: Feedback Port (F1 and F2) Breakout Board Dimensions

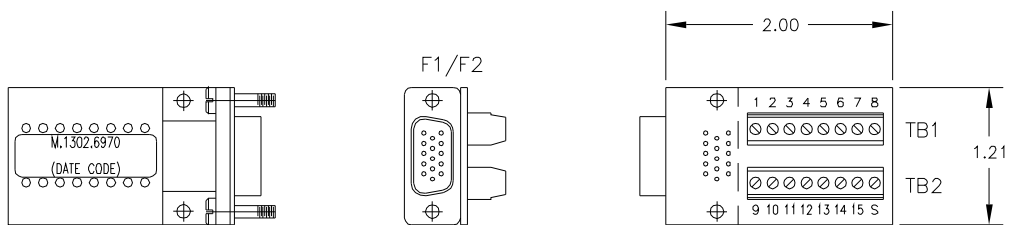

DANAHER MOTION PART NUMBER	DANAHER MOTION SHORT DESCRIPTION
M.1302.6970	BKOUT BD,F1/F2,MMC-SD DR MT

5.1.4.2 Feedback Port (F1/F2) to Motor Cables

Cables are available that allow easy connection between the F1 & F2 Feedback Ports and various Kollmorgen motors. These cables are outlined in [Table 5-11](#). The wiring diagram for each cable is located in the indicated Table. For information on Non-Flex versus Hi-Flex cables, refer to [section 10.1 on page 287](#).

Table 5-11: F1/F2 to AKM/DDR Motor Cables^a			
Feedback	Non-Flex P/N	Hi-Flex P/N	Wiring Diagram
Incremental Encoder	Not Available	CF-CB7374N-XX-0	Table 5-12 on page 94
Endat/BiSS ^b	VF-SB4474N-XX	CF-SB7374N-XX-0	Table 5-13 on page 95
Resolver ^b	VF-RA2474N-XX	CF-RA2574N-XX-0	Table 5-14 on page 96
SFD	VF-DA474N-XX	CF-DA0374N-XX-0	Table 5-15 on page 97

a. "XX" in the above table denotes the length of the cable, in meters. Standard "XX" values are 01, 03, 06, 09, and 12. Hi-Flex cables are available in additional lengths. Consult Kollmorgen for more information.

b. Feedback type not available on F2

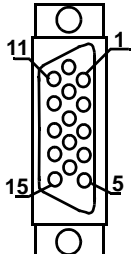
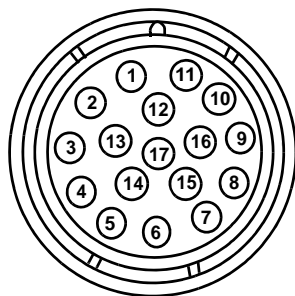
Table 5-12: Feedback Port (F1/F2) Encoder to AKM/DDR Motor				
For Part Numbers, Table 5-11 on page 93				
Twisted Pair 24 AWG (Except as noted)	D-sub 15-Pin HD Male Connector to MMC Smart Drive		Connector to Motor	
				
Wire Color	Pin Number	Signal Type	Pin Number	Signal Type
Yellow	12	A	3	A
Yellow/Black	13	A/	4	A/
Brown	14	B	1	B
Brown/Black	15	B/	2	B/
Orange	6	I	5	I
Orange/Black	7	I/	6	I/
Green	1	S1 ^a	15	S1
Black	2	S2 ^a	16	S2
White	3	S3 ^a	17	S3
Blue	8	Temperature+	8	Temperature+
Blue/Black	9	Temperature-	9	Temperature-
Grey	4	+5V Sense+	10 ^b	+5V Sense+
Grey/Black	5	+5V Sense-	7 ^c	+5V Sense-
Red ^d	10	+5 VDC	10 ^b	+5 VDC
Inner Braid ^d	11	COM	7 ^c	COM
Outer Braid	Shell	Shield	Shell	Shield
N/C		N/A	11-14	N/C

- a. Only applicable to F2 connector
- b. There are two wires in pin10
- c. There are two wires in pin 7
- d. This wire is 22 AWG

Table 5-13: Feedback Port (F1) Endat/BiSS to AKM/DDR Motor

For Part Numbers, [Table 5-11 on page 93](#)

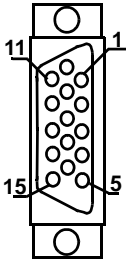
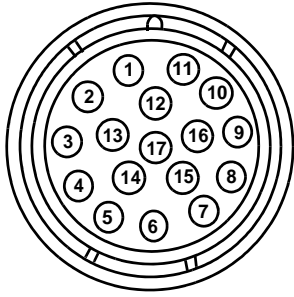
Twisted Pair 28 AWG (Except as noted)	D-sub 15-Pin HD Male Connector to MMC Smart Drive		Connector to Motor	
				
Wire Color	Pin Number	Signal Type	Pin Number	Signal Type
Green	12	Sine	11	Sine
White/Green	13	Sine/	3	Sine/
Blue	14	Cos	9	Cos
White/Blue	15	Cos/	1	Cos/
Red	6	RS-485 Data+	5	RS-485 Data+
White/Red	7	RS-485 Data-	13	RS-485 Data-
Black	2	RS-485 Clock+	8	RS-485 Clock+
White/Black	3	RS-485 Clock-	15	RS-485 Clock-
Yellow	8	Temperature+	7	Temperature+
White/Yellow	9	Temperature-	14	Temperature-
Orange ^a	4	+5V Sense+	4 ^b	+5V Sense+
White/Orange ^a	5	+5V Sense-	2 ^c	+5V Sense-
Grey ^d	10	+5 VDC	4 ^b	+5 VDC
White/Grey ^d	11	COM	2 ^c	COM
Outer Braid	Shell	Shield	Shell	Shield
N/A	N/A	N/A	6,10,12,16,17	N/C
N/A	1	N/C	N/A	N/A

- a. This wire is 22 AWG
- b. There are two wires in pin 4
- c. There are two wires in pin 2
- d. This wire is 16 AWG

Table 5-14: Feedback Port (F1) Resolver to AKM/DDR Motor

For Part Numbers, [Table 5-11 on page 93](#)

Twisted Pair 28 AWG	D-sub 15-Pin HD Male Connector to MMC Smart Drive		Connector to Motor	
				
Wire Color	Pin Number	Signal Type	Pin Number	Signal Type
Yellow	12	Sin+	8	Sin+
White/Yellow	13	Sin-	4	Sin-
Blue	14	Cos	7	Cos
White/Blue	15	Cos-	3	Cos-
Black	6	Carrier+	9	Carrier+
White/Black	7	Carrier-	5	Carrier-
Red	8	Temperature+	2	Temperature+
White/Red	9	Temperature-	6	Temperature-
Outer Braid	Shell	Shield	Shell	Shield
N/A	N/A	N/A	1,10-12	N/C
N/A	1-5,10,11	N/C	N/A	N/A

Table 5-15: Feedback Port (F1/F2) SFD to AKM/DDR Motor

For Part Numbers, [Table 5-11 on page 93](#)

Wire gauge as noted	D-sub 15-Pin HD Male Connector to MMC Smart Drive		Connector to Motor	
				
Wire Color	Pin Number	Signal Type	Pin Number	Signal Type
Red ^a	10	+5V Source	1	+5V Source
Drain ^a	11	Common	2	Common
Green ^b	7	Com-	3	Com-
White ^b	6	Com+	4	Com+
Inner Braid	N/C	N/A	5	Shield
Outer Braid	Shell	Shield	Shell	Shield
N/A	N/A	N/A	6-12	N/C
N/A	1-5,12-15	N/C	N/A	N/A

a. This wire is 22 AWG

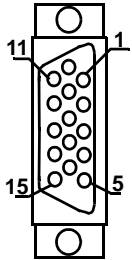
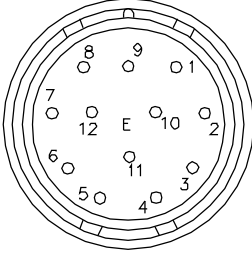
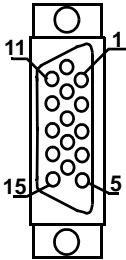
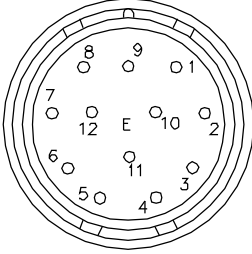
b. This wire is 24 AWG

5.1.5 Drive I/O Connectors (IO1 & IO2)

The two 10-pin pluggable screw-terminal connectors (labeled "IO1" and "IO2" on the front of the Drive) provide connection between various devices and the Drive. These connectors provide one Analog Input, one Analog Output, two Fast Inputs, a relay output, six General Purpose Inputs, and two General Purpose Outputs (wiring example shown in [See Figure 5-4 on page 101](#)).

- Pin descriptions are provided in [Table 5-16](#)
- Pin assignments are provided in [Table 5-17](#)

Table 5-16: Pin Description for Drive I/O Connectors (IO1 & IO2)

Signal Type	Notes	IO1 Pins	IO2 Pins
Analog Input	Analog Input of -10VDC to +10VDC	1, 2	
Analog Output	Analog Output of -10VDC to +10VDC	2, 3	
General Purpose Software Assignable Outputs	24VDC sourcing type	5, 6	
General Purpose Output power	24 VDC input for powering GPOUTs	7, 8	
Relay Output	Mechanical Relay Output	9, 10	
Fast Inputs	24VDC (nominal) Inputs, configurable as Sinking or Sourcing. Used for latching encoder position.		1, 2
Fast Input Sink/Source	This pin determines whether the Fast Inputs are sourcing (this pin connected to 24 Vdc) or sinking (this pin connected to 24 Vdc Common)		3
General Purpose Software Assignable Inputs	24VDC (nominal) Inputs, configurable as Sinking or Sourcing		4, 5, 6, 7, 8, 9
General Purpose Inputs Sink/Source	This pin determines whether the General Purpose Inputs are sourcing (this pin connected to 24 Vdc) or sinking (this pin connected to 24 Vdc Common)		10

Table 5-17: Pin Assignment for Drive I/O Connectors (IO1 & IO2)

Connector IO2				Connector IO1				Connector Pinout
Pin	Wiring Label	PiCPro I/O Label	In/Out	Pin	Wiring Label	PiCPro I/O Label	In/Out	
1	FASTIN1	Input 7	In	1	Analog In-	Analog Input	In	Dual 10-pin Pluggable Screw-terminal Connector
2	FASTIN2	Input 8	In	2	Analog In+		In	
3	FASTIN Sink/Source		In	3	Analog Out	Analog Output	Out	
4	GPIN1	Input 1	In	4	Analog Out Return		In	
5	GPIN2	Input 2	In	5	GPOUT1	Output 1	Out	
6	GPIN3	Input 3	In	6	GPOUT2	Output 2	Out	
7	GPIN4	Input 4	In	7	GPOUT 24VDC		In	
8	GPIN5	Input 5	In	8	GPOUT 24VDC Return		In	
9	GPIN6	Input 6	In	9	Relay	Output 3	Out	
10	GPIN Sink/Source		In	10			Out	

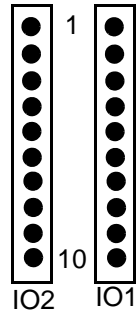
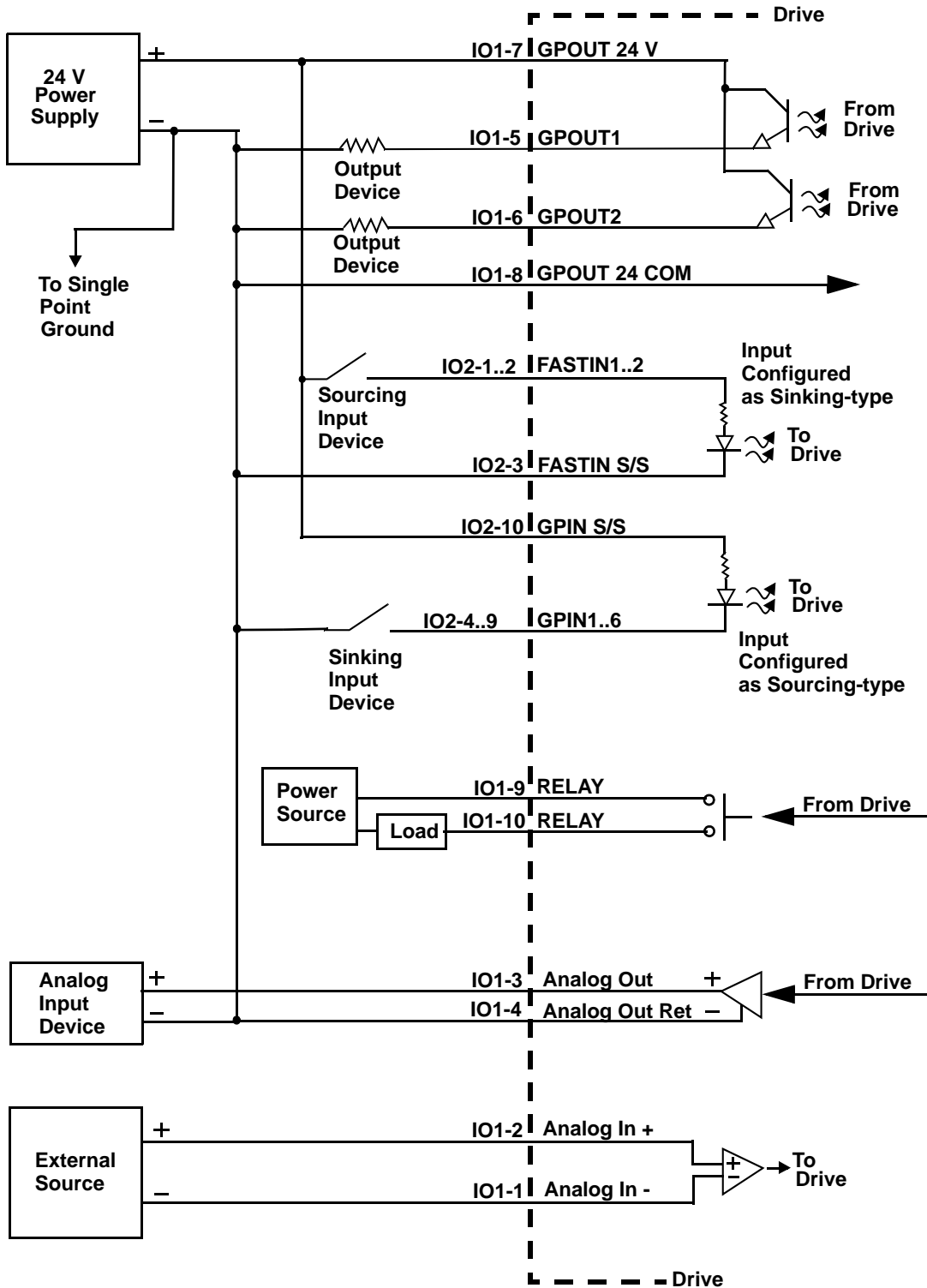

Figure 5-4: Wiring Diagram for Drive I/O Connectors (IO1 & IO2)



5.2 Power Section Connectors

This section describes the connectors located on the Power Section (left portion) of the drive.

5.2.1 DC Power Connector

The DC Power Connector consists of a plugable 3-pin screw-terminal block, and provides +24VDC (nominal) Logic Power to the drive, as well as the "Safe Torque Off" Enable signal.

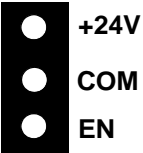
Terminal Label	Signal Type	Signal Description	PiCPro I/O Label	In/Out	Connector Pinout
+24V	Logic Power	+24V user supplied power signal terminal.	N/A	In	3-pin Plugable Screw Terminal 
COM	Common	+24V Common	N/A	In	
EN	Drive Enable	Safe-off Signal. (See section 5.2.1.1 on page 102).	N/A	In	

5.2.1.1 "EN" requirements and Safe-off Operation

The Drive contains Safe-off capability. **The "EN" pin located on the 3-pin DC PWR connector must have 24Vdc applied to it in order for the drive to operate.**

The following two sections describe the behavior of Safe-off function.

5.2.1.1.1 "EN" Operation

The Drive will only perform a Safe-off fault if the following two conditions are met:

- The drive is enabled by the application
- The "EN" input pin is not at 24Vdc

The general sequence of operation of the Safe-off function is as follows:

1. An external user-supplied circuit provides 24Vdc to the "EN" input
2. The drive is enabled via the Application Program
3. The application controls the motor as desired
4. The drive is disabled via the Application Program
5. The external user-supplied circuit removes 24Vdc from the "EN" input
6. The process is repeated starting with step 1 above as required

If during step 3 above, the user-supplied external circuitry removes 24Vdc from the "EN" input (usually due to a safety violation on the equipment being controlled), the drive will fault, and the motor will coast to a stop. The drive must be powered off and back on to remove the fault condition.

5.2.2 AC Power Connector

The Power Connector consists of a pluggable 4-pin screw-terminal block, and provides connection to the incoming AC power.

Note: On the 3A, 6A, and 12A Drives, the AC Power Connections are located on the lower four pins of the AC Power/Regen Connector, with Ground located at the bottom, followed by L3, L2, and L1.

Table 5-19: Pin Assignment for Drive Power Connector				
Terminal Label	Signal Type	Signal Description	In/Out	Pin Sequence
L1	AC Power	100-240VAC single or three-phase power in to drive.	In	4-pin Pluggable Screw Terminal
L2				
L3				
	Protective Ground	Must be connected to Protective Earth Ground (SPG).	In	

SINGLE PHASE CONNECTION
If single-phase power is used, L1 must be connected to "hot", and L2 must be connected to "neutral". L3 must remain unconnected.

5.2.2.1 Line Fusing

See [section 4.2 on page 40](#) for additional information on Drive Protection.

5.2.3 Motor/Brake Connector

The Motor/Brake Connector consists of a pluggable 6-pin screw-terminal block, and provides connection to the motor and the motor brake that is being controlled by the Drive.

Table 5-20: Pin Assignment for Motor/Brake Connector				
Terminal Label	Signal Type	Signal Description	In/Out	Pin Sequence
-BR	Brake Relay -	Motor brake control ^a	In	6-pin Pluggable Screw Terminal
+BR	Brake Relay +		Output3	
	Protective Ground	Must be connected to Protective Earth Ground (SPG).	In	
U	Motor Power	Power U-phase from the drive to the motor.	Out	
V		Power V-phase from the drive to the motor.	Out	
W		Power W-Phase from the drive to the motor.	Out	

a. This output can be defined and used as a General Purpose Output in PiCPro (Output3), but is typically defined as the Motor Brake Control.

NOTE
Use of a diode (as shown) or an external RC type snubber is highly recommended for use with inductive loads, especially DC inductive loads.

Figure 5-5: BR+ and BR- Wiring Examples

Using External Power Source

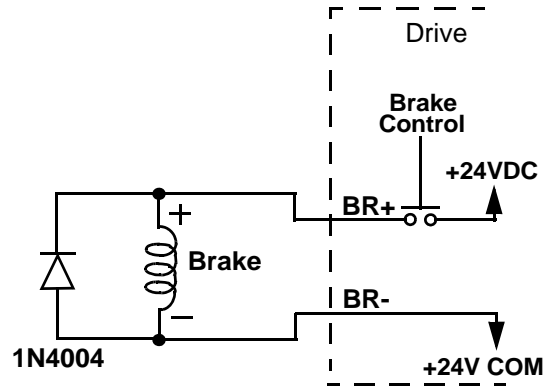

5.2.3.1 Motor/Brake Cables

Cables are available that allow easy connection to the between the Motor Power connector and Kollmorgen AKM/DDR motors. These cables are outlined in [Table 5-21](#). For a detailed description of these cables, refer to the Kollmorgen "AKD/S700 Accessories Manual" which can be found at www.kollmorgen.com. For information on Non-Flex versus Hi-Flex cables, refer to [section 10.1 on page 287](#).

Table 5-21: Motor Connector to AKM/DDR Motor Cables^a				
Drive	Non-Flex P/N	Non-Flex (w/brake) P/N^a	Hi-Flex P/N^a	Hi-Flex (w/brake) P/N^a
MMC-SDN-0.9-230-D MMC-SDN-1.8-230-D	VP-507BEAN-XX	VP-508CFAN-XX	CP-507CCAN-XX	CP-507CDAN-XX
MMC-SDN-3.6-230-D	VP-508CEAN-XX	VP-508CFAN-XX	CP-507CCAN-XX	CP-507CDAN-XX
MMC-SDN-7.2-230-D	VP-508DEAN-XX	VP-508DFAN-XX	CP-508EBDN-XX	CP-508EBDN-XX

a. "XX" in the above table denotes the length of the cable, in meters. Standard "XX" values are 01, 03, 06, 09, and 12. Hi-Flex cables are available in additional lengths. Consult Kollmorgen for more information.

5.2.3.2 Motor Chokes

If a motor cable over 25 meters is used, a Motor Choke must be installed. These chokes are outlined in [Table 5-22](#). For a detailed description of these chokes, refer to the Kollmorgen "AKD/S700 Accessories Manual" which can be found at www.kollmorgen.com.

Table 5-22: Motor Chokes	
Drive	Choke Part Number
MMC-SDN-0.9-230-D MMC-SDN-1.8-230-D	3LYN-06
MMC-SDN-3.6-230-D	3LYN-14
MMC-SDN-7.2-230-D	3LYN-24

5.2.4 DC Bus/Regen Connector

The DC Bus/Regen Connector consists of a pluggable 4-pin screw-terminal block, and provides connection to the drives DC Bus and to an external Regen resistor.

Note: On the 3A and 6A Drives, the DC Bus/Regen Connections are located on the upper three pins of the AC Power/Regen Connector, with -RB on top, followed by -DC and +RB (note that there is no -Ri connection since these Drives do not have internal Regen resistors)

Note: On the 12A Drive, the DC Bus/Regen Connections are located on the upper four pins of the AC Power/Regen Connector, with -Ri on top, followed by -RB, -DC, and +RB.

ADDITIONAL SHUNT RESISTOR INFORMATION
Refer to section 4.5 on page 58 for instructions on choosing, mounting, and connecting Shunt Resistors available from Kollmorgen.

Terminal Label	Signal Description	In/Out	Pin Sequence
+Ri	Internal Regen resistor ^a	Out	4-pin Pluggable Screw Terminal
-RB	Regen Resistor Control	Out	
-DC	-DC Bus Output	Out	
+RB	+DC Bus Output	Out	

a. Not present on the 3A and 6A Drives

5.2.4.1 Bus/Regen Connections

Use the following guidelines when making connections to the Bus/Regen Connector:

- To use the Regen resistor contained within the Drive (12A and 24A Drives only), connect +Ri to -RB with a jumper
- To use an external Regen resistor, connect the resistor between +RB and -RB
- To use DC Bus Sharing between the Drive and one or more additional drives:
 - Connect +RB to the connected drive's +DCBUS
 - Connect -DC to the connected drive's -DCBUS

5.2.4.2 External Regen Resistors

There may be applications where an external regen resistor is required (even on the 12A and 24A Drives which contain internal regen resistors). Available external regen resistors are outlined in [Table 5-24](#). For a detailed description of these resistors, including mounting information, refer to the Kollmorgen “AKD/S700 Accessories Manual” which can be found at www.kollmorgen.com.

For Drive	Shunt Resistor Module	Part Number
MMC-SDN-0.9-230-D MMC-SDN-1.8-230-D MMC-SDN-3.6-230-D	33Ω, 100W Cont. Power, 160W Peak Power	BAFP-100-33
	33Ω, 200W Cont. Power, 320W Peak Power	BAFP-200-33
	33Ω, 250W Cont. Power, 400W Peak Power	BAR-250-33
	33Ω, 500W Cont. Power, 800W Peak Power	BAR-500-33
	33Ω, 1.5kW Cont. Power, 2.4kW Peak Power	BAR-1500-33
	33Ω, 3kW Cont. Power, 4.8kW Peak Power	BAR-3000-33
MMC-SDN-7.2-230-D	15Ω, 500W Cont. Power, 800W Peak Power	BAR-500-15
	15Ω, 1kW Cont. Power, 1.6kW Peak Power	BAR-1000-15
	15Ω, 2kW Cont. Power, 3.2W Peak Power	BAS-2000-15
	15Ω, 3kW Cont. Power, 4.8kW Peak Power	BAS-3000-15
	15Ω, 6kW Cont. Power, 9.6kW Peak Power	BAS-6000-15

5.3 Specifications - 230V MMC Smart Drive NextGen

5.3.1 General Data

General Drive Data	
Minimum wire size for AC PWR, REGEN, and MOTOR connectors	3A & 6A Drives: 1.5mm ² (16 AWG), 75° C copper. 12A Drive: 2.5mm ² (14 AWG), 75° C copper. 24A Drive: 4mm ² (12 AWG), 75° C copper.
Minimum wire characteristics for AC PWR, REGEN, and MOTOR connectors	AC PWR: 600V, 75° C, copper REGEN: 1,000V, 75° C, copper, shielded MOTOR: 600V, 75° C, copper, shielded, C <150 pF/m
Recommended tightening torque for AC PWR, REGEN, and MOTOR connectors	3A & 6A Drives: 5-7 in-lbs 12A Drive AC PWR & Regen: 5-7 in-lbs 12A Drive Motor: 7 in-lbs 24A Drive: 7 in-lbs
Recommended tightening torque for DC PWR connector	4 in-lbs
Recommended tightening torque for Drive I/O connectors	2 in-lbs
Commutation	Three Phase Sinusoidal
Current Regulator	Digital PI 125 µsec. update rate
Velocity Regulator	Digital PID - 250 µsec. update rate
Environmental Data	
Operating Temperature Range (Surrounding Air)	0° C to 40° C (32° F to 104° F). Derate output 4% per 4° C (1.8° F) from 40° C to 55° C (104° F to 131° F)
Storage Temperature Range	-25° C to 55° C (-13° F to 131° F)
Transport Temperature Range	-25° C to 70° C (-13° F to 158° F)
Humidity	5% to 85% non-condensing
Altitude	1,000 m (3,281ft) Derate 1.5%/100m from 1,000m to 2,500m
Pollution	Pollution level 2 per IEC 60644-1
Vibration Limits (per IEC 68-2-6) Operating/Non-operating	10-57 Hz (constant amplitude.15 mm) 57 - 2000 Hz (acceleration 2 g)
Shock (per IEC 68-2-27) Non-operating	Four shocks per axis (15g/11 msec)

Conformity	
CE Marked (pending)	Conforms to Low Voltage Directive 73/23/EEC (amended by 93/68/EEC) and EMC Directive 89/336/EEC (amended by 92/31/EEC and 93/68/EEC). Conformance is in accordance with the following standards: EN 50178 and EN61800-3
UL and C/UL Listed (pending)	E233454
DC Input Power Specifications (24VDC)	
Input Voltage Range	24 VDC +/-10%
Typical Input Current (does not include Brake Output current)	3A Drive: 0.5A 6A Drive: 0.6A 12A Drive: 0.7A 24A Drive: 1.0A
Typical Input Wattage	15.6 W
Inrush Current	Not Specified
F1 and F2 Feedback Inputs	
Input receiver type	Maxim 3098 A quad B differential RS422 receiver
Encoder signals	Differential quadrature
Input threshold	±200 mV
Input termination	150Ω, provided internally
Maximum input voltage	5V peak to peak differential -10 to +13.2V common mode
Maximum input signal frequency	720 K Hz (2.88 M feedback counts per second)
+5V regulated output	F1 = 350ma, F2 = 200ma

F2 Connector Encoder Emulation Output	
<p>Note: The F2 connector can be configured provide an emulated Output of the encoder connected to F1, as described below. When so configured, a feedback device (Incremental Encoder or SFD), cannot be connected to F2.</p>	
F1 Motor Feedback Type	<ul style="list-style-type: none"> • Input Limit • Maximum Encoder Emulation Output Rate • Emulated Output Description
Incremental Encoder	<ul style="list-style-type: none"> • 720 KHz • 2.88 M counts/sec. • The motor encoder A/B/I inputs are electrically buffered and can be retransmitted out of the F2 connector.
High Resolution Encoder SFD	<ul style="list-style-type: none"> • 100 KHz • 400 K counts/sec. • The encoder SIN/COS signals are electrically squared and retransmitted as A/B. The index mark "I" is synthesized by the Drive. Absolute position information is not available via the Encoder Emulation Output.
Resolver	<ul style="list-style-type: none"> • 500 RPS • 2.00 M counts/sec. • The resolver inputs are converted to 4096 lines/16384 counts per revolution of A/B encoder output. The Drive synthesizes the index mark "I" once per revolution of the resolver. Absolute position information is not available via the Encoder Emulation Output.
General Purpose Inputs	
Configuration	<ul style="list-style-type: none"> • 6 optically isolated 24V DC Inputs • Sink or Source in group of 6 • 2 optically isolated 24V DC Fast Inputs • Sink or Source in group of 2
Guaranteed On	15 VDC
Guaranteed Off	5 VDC
Time delay on	1 ms max. (3us for Fast Inputs)
Time delay off	1 ms max (50us for Fast Inputs)
Input voltage	Nominal 24 VDC, maximum 30 VDC

EN (Safe-off) Input	
Configuration	24Vdc (nominal) = Drive Enabled
Guaranteed On	15 VDC
Guaranteed Off	5 VDC
Input Current, Typical	25mA.
General Purpose Outputs	
Configuration	<ul style="list-style-type: none"> • 2 optically isolated 24V DC outputs • Active high • Current sourcing only (current into load) • Short circuit and overload protected
Maximum current	50mA per output
Voltage range	24VDC +15%-10%
Time delay on for resistive loads	50 μ sec. max
Time delay off for resistive loads	50 μ sec. max
Leakage current in off state	0.5 mA max
Relay Output (on Control Board)	
Configuration	Normally Open mechanical contact
Maximum current	2A
Voltage range	24VDC +/-10%
Time delay on for resistive loads	3 msec. max
Time delay off for resistive loads	5 msec. max
Brake Control Output (on Power Board)	
Configuration	Solid State Switch
Maximum current	1.5A (3A, 6A, 12A Drive), 2A (24A Drive)
Voltage range	24VDC +/-10%
Time delay on for resistive loads	50 μ sec. max
Time delay off for resistive loads	50 μ sec. max

General Purpose Analog Input	
Input Characteristics	-10VDC to +10VDC 14 bit effective resolution
General Purpose Analog Output	
Output Characteristics	-10VDC to +10VDC 16 bit effective resolution
Digital Link In/Out Ports	
"In" port	Sends and receives high speed data to and from connected MMC-SD's "Out" port.
"Out" port	Sends and receives high speed data to and from connected MMC-SD's "In" port.
Cable Type	Shielded, Straight Pinned, CAT5 or better (CAT5e, CAT6, etc.)
Maximum Cable Length	30 m (98.4 ft)

5.3.2 Physical and Electrical Data

	Model			
	MMC-SDN-0.9-230-D	MMC-SDN-1.8-230-D	MMC-SDN-3.6-230-D	MMC-SDN-7.2-230-D
Part Numbers	M.3000.1425	M.3000.1426	M.3000.1427	M.3000.1428
Weight, lbs (kg)	3.3 (1.5)	3.3 (1.5)	5.4 (2.5)	9.3 (4.2)
AC Input Specifications, Single Phase Input (Three Phase Input)				
Input Power (kVA)	1.20	2.38	3.82	7.60
Number of Phases	1 or 3			
Input Voltage, VAC	100-240			
Input Frequency, Hz	47 - 63 ^a			
Input Current Amps RMS,	5.0 (2.3)	9.9 (4.6)	12 (9.2)	24 (18.3)
Maximum Inrush Amps 0-Peak	10	10	10	20
Power Loss, Watts	31	57	137	175
AC Output Specifications				
Note: AC Output is specified at an ambient of 0° C to 40° C (32° F to 104° F). Derate output 4% per 4° C (1.8° F) from 40° C to 55° C (104° F to 131° F)				
Output Current (Amps)				
Continuous RMS	3	6	12	24
Continuous 0-Peak	4.2	8.5	17	34
Peak 0-Peak	12.7	25.5	42.4	67.9
Continuous Output Power				
Input = 120 VAC, Watts	312.5	625	1250	2500
Input = 240 VAC, Watts	625	1250	2500	5000

Peak Output Power (1sec)				
Input = 120 VAC, Watts	937	1,875	3,125	5,000
Input = 240 VAC, Watts	1,875	3,750	6,250	10,000
Output Frequency, Hz	0-800			
Energy Absorbion Specifications				
DC Bus Capacitance (Internal)	940 μ F	2,460	2,720	
Bus overvoltage threshold	420 VDC			
Joules available for energy absorption				
120VAC line input	60 joules	160 joules	180 joules	
240 VAC line input	20 joules	55 joules	60 joules	

a. May also be used with 64-420Hz input power, with limited output capability

5.4 Dimensions

This section contains dimensional information on the Drives. Use this information to determine mounting hole locations on the drive panel.

When locating the drive on the panel, observe the clearance requirements found in [Table 3-1 on page 21](#). Mount the drive to the panel with #10 bolts and #10 star washers (to ensure proper ground connection).

Figure 5-6: 3 and 6 Amp Drives - Front View

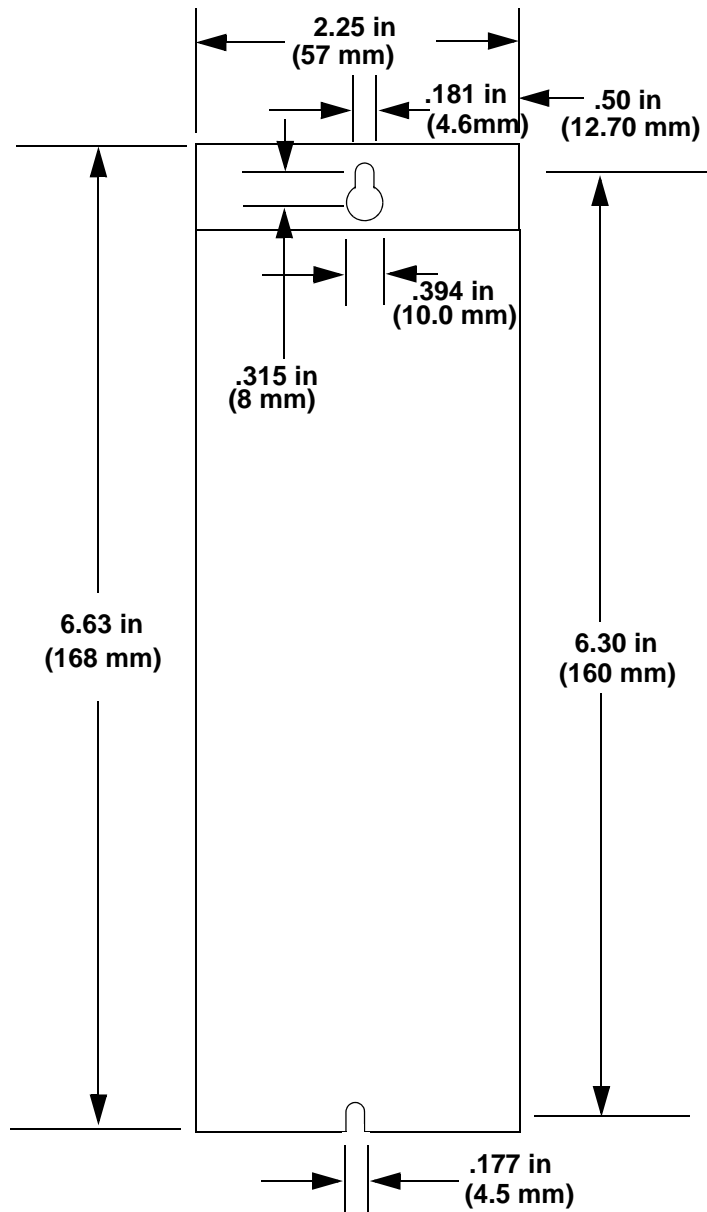

Depth (to front surface of Drive): 6.09" (155mm)

Figure 5-7: 12 Amp Drive - Front View

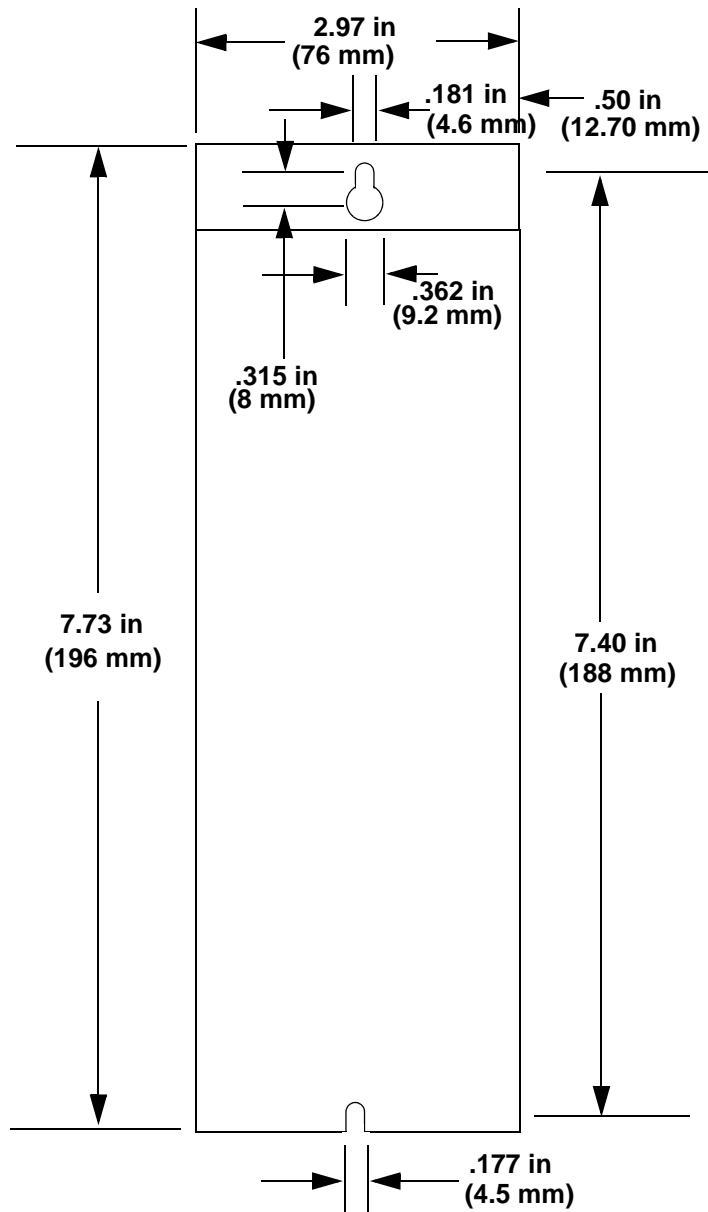

Depth (to front surface of Drive): 7.31" (186mm)

Figure 5-8: 24 Amp Drive - Front

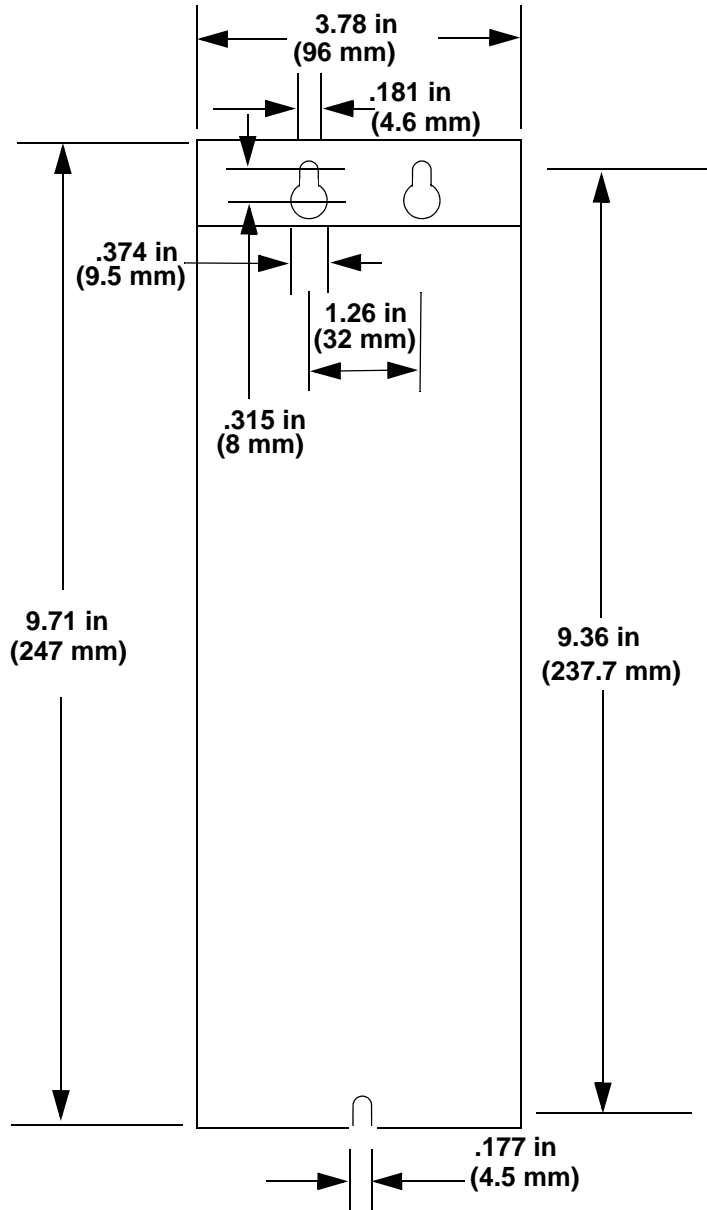

Depth (to front surface of Drive): 8.93" (227mm)

6 460V 3 Phase MMC Smart Drive NextGen

The 460V Smart Drive NextGen (the Drive) is an AC Servo Drive capable of driving a wide range of Brush-type and Brushless DC motors.

The Drive's Power Section features the following:

- May be connected to a wide range of Mains power:
 - 200-480VAC, 50/60Hz, 3 phase
 - May also be used with 100-200VAC, 1 or 3 phase, with limited output capability
- Built-in regen resistor
 - Supports external regen resistors if required by application
- Brake Output (this can also be used as a General Purpose Output)
- Supports DC bus sharing
- Safe Torque Off capability

The Drive's Control Section features the following:

- Connects to Kollmorgen's Digital Link bus
- Two-digit error/status display
- A primary feedback connector (F1), containing the following features:
 - High density female DB-15 connector
 - Supports the following feedback devices:
 - Incremental Encoder (without halls)
 - Stegmann Hiperface encoder
 - High Resolution Resolver
 - 1V p-p Sinewave Encoder
 - Endat 2.1 (2.2 in future release)
 - BiSS (Mode B)
 - SFD (Smart Feedback Device). Note: An SFD can be connected to F1 or F2, not both
- A secondary feedback connector (F2), containing the following features:
 - High density female DB-15 connector
 - This connector can support one of the following functions:
 - Emulated F1 encoder output
 - Comcoder Input (Incremental Encoder with halls)
 - SFD Input (Smart Feedback Device). Note: An SFD can be connected to F1 or F2, not both.
- I/O connectors, containing the following features:

- Two pluggable 10-pin screw-terminal connectors
- Two Fast DC Inputs (sink or source in group of two)
- Six General Purpose DC Inputs (sink or source in group of six)
- Two General Purpose DC Outputs (sourcing)
- Analog Input
- Analog Output
- Relay Output

Figure 6-1: Front Panel, SDN Drives

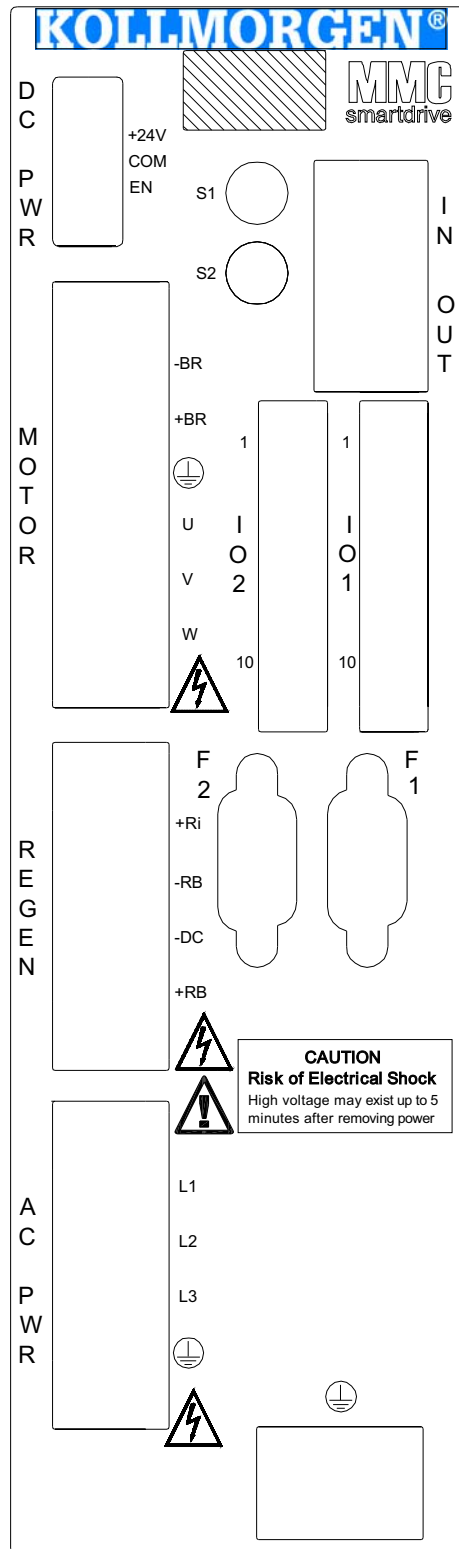

6.1 Control Section Connectors, Switches, LEDs

This section describes the connectors, switches, and LEDs located on the Control Section (right portion) of the drive.

6.1.1 Status Display

The Status Display is located on the top-front of the drive, and consists of two 7-segment displays. The Status Display will indicate the Drive's current operating condition, including error codes. Refer to the PiCPro Help for the description of the various display conditions.

6.1.2 Node Address Rotary Switches

Two rotary switches are used to set the drive address. Rotate the switch to the desired address.

Addresses can be set to any number from 1 through 64. The top switch (S1) represents values of base ten. The bottom switch (S2) represents values of base 1.

As an example, rotating S1 to a setting of 2 equals the value of 20 (2 x 10). Rotating S2 to a setting of 5 equals the value of 5. The actual address setting is 25 (20 + 5).

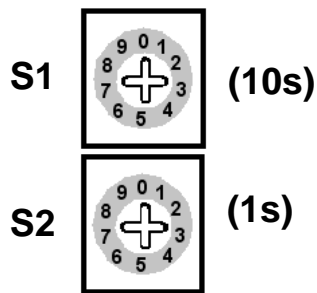

6.1.3 Digital Link Ports

The two 8-pin RJ-45 Digital Link Port connectors (labeled "IN" and "OUT" on the front of the Drive) provide communications between the Drive and other Digital Link devices (another Digital Drive, a Standalone MMC Digital Control, Slice I/O Coupler, DL-DIU, etc.). There is a green "Link" light located in the upper-right corner of each connector. If this light is on, another Digital Link device is properly connected to the associated "IN" or "OUT" port.

A "straight-through" shielded cable must be used when connecting the Drive to other Digital Link devices. Connect a cable from another Digital Link device's "OUT" port to the Drive's "IN" port, and another cable from the Drive's "OUT" port to the next Digital Link device's "IN" port.

- Pin descriptions for are provided in [Table 6-1](#)
- Pin assignments are provided in [Table 6-2](#)
- The available Digital Link Port to Digital Drive cables are described in [Table 6-3](#)

Table 6-1: Digital Link Port Pin Description

Digital Link Connector (IN/OUT) Signals		Pin	
Function	Notes	"In" Connector	"Out" Connector
Receive Data +	Receives data from connected drives.	1	3
Receive Data -	Receives data from connected drives.	2	6
Transmit Data +	Transmits data to connected drives.	3	1
Transmit Data -	Transmits data to connected drives.	6	2
Protective Ground	Provides a path for the ground signal to an external single point ground.	Connector Shell	Connector Shell

Table 6-2: Digital Link Port Pin Assignments			
Pin	Label	In/Out	Connector Pinout
IN Connector			
1	Receive +	In	<p>RJ-45 Connectors</p>
2	Receive -	In	
3	Transmit +	Out	
4	Not Used	N/A	
5	Not Used	N/A	
6	Transmit -	Out	
7	Not Used	N/A	
8	Not Used	N/A	
Connector Shield	Provides a path for the ground signal to an external single point ground.	In	
OUT Connector			
1	Transmit +	Out	
2	Transmit -	Out	
3	Receive +	In	
4	Not Used	N/A	
5	Not Used	N/A	
6	Receive -	In	
7	Not Used	N/A	
8	Not Used	N/A	
Connector Shield	Provides a path for the ground signal to an external single point ground.	In	

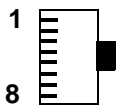
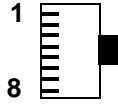
Table 6-3: Digital Link Port “IN” to “OUT” Cables				
Part Numbers: .3 M (1.0 ft): M.1302.8285 .6 M (2.0 ft): M.1302.8286 1 M (3.3 ft): M.1302.8287 2 M (6.6 ft): M.1302.8288 3 M (9.8 ft): M.1302.8289 5 M (16.4 ft): M.1302.8300 10 M (32.8 ft): M.1302.8301 15 M (49.2 ft): M.1302.8302 30 M (98.4 ft): M.1302.8303 Cable type: 28 AWG, shielded, twisted pair, 8 conductor.				
8-Pin RJ-45 Plug (to Digital Link Port “OUT”, face view) 		8-Pin RJ-45 Plug (to Digital Drive “IN”, face view) 		
Pin	Signal	Pin	Signal	Notes
1	Transmit Data +	1	Receive Data +	Twisted
2	Transmit Data -	2	Receive Data -	Pair
3	Receive Data +	3	Transmit Data +	Twisted
6	Receive Data -	6	Transmit Data -	Pair
4	None	4	None	Twisted
5	None	5	None	Pair
7	None	7	None	Twisted
8	None	8	None	Pair
Shell	Drain	Shell	Drain	

6.1.4 Feedback Connectors (F1 & F2)

The two 15-pin female Feedback connectors (labeled “F1” and “F2” on the front of the Drive) provide an interface between two feedback devices. A detailed description of the capabilities and limitations of connected devices can be found in [section 6.1.4.1 on page 130](#).

- Pin descriptions for the F1 connector are provided in [Table 6-4](#)
- Pin assignments for the F1 connector are provided in [Table 6-5](#)
- Pin descriptions for the F2 connector are provided in [Table 6-6](#)
- Pin assignments for the F2 connector are provided in [Table 6-7](#)
- The available Flying Lead cable is described in [Table 6-9](#).
- Available Breakout Boxes and Cables are described in [Table 6-10](#).
- Breakout Box dimensions are shown in [Figure 6-2](#)
- Breakout Board dimensions are shown in [Figure 6-3](#)
- Feedback Port to Motor Cables are described in [section 6.1.4.2 on page 135](#)

Table 6-4: Pin Description for Feedback Connector (F1)

F1 Feedback Signals			
Signal Type	Signal Name	Notes	Pin
Incremental Encoder Inputs	A1, A1/, B1, B1/, I1, I1/	Differential A quad B encoder signals.	12, 13, 14, 15, 6, 7
Sinewave Encoder Inputs	Sin, Sin/, Cos, Cos/	Sinewave Encoder signals	12, 13, 14, 15
Sinewave Encoder Data Channel In/Out	RS-485 Data +, RS-485 Data -, RS-485 Clock+, RS-485 Clock-	RS-485 signals for connecting the Sinewave Encoder Data Channel to the drive	6, 7, 2, 3
SFD Communication Channel	Com+, Com-	SFD communication signals. An SFD can be connected to F1 or F2, not both	6, 7
Resolver Inputs	Sin+, Sin-, Cos+, Cos-	Resolver stator feedback signals	12, 13, 14, 15
Resolver Outputs	Carrier+, Carrier-	Resolver rotor excitation signals.	6, 7
Temperature Input	Temperature	Thermostat (normally- closed) or Thermistor (Phillips KTY84-130 PTC or equivalent recommended) input for detecting over temperature conditions within the motor. These inputs are shared with F2.	8, 9
+5V Encoder Power Outputs	+5V Source	Regulated +5VDC for powering the attached encoder (350ma max).	10
+5V Encoder Power Sense Lines	+5V Sense+, +5V Sense-	These signals should be tied to the +5V power and ground lines at the encoder.	4, 5
Signal and Power Common	Common	Return path for feedback signals and +5V power output	11

PROVIDING 8VDC ENCODER POWER

Some Encoders, specifically the Stegmann Hiperface, require 8VDC power to operate. 8VDC Power can be provided on pins 10 and 11 by connecting the +5V Sense Lines (pins 4 & 5) together.

Table 6-5: Pin Assignments for Feedback Connector (F1)

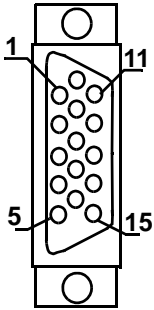
Pin	Feedback Device							In/ Out	Connector Pinout
	Digital Incremental Encoder	Sinewave Encoder		BISS ^a	1V p-p Sine Wave	SFD ^b	Resolver		
		Hiper- face ^c	Endat ^d						
1	N/U (Not Used)								15-pin Female HD D-Sub 
2	N/U	RS-485 Clock+		N/U			Out		
3	N/U	RS-485 Clock-		N/U					
4	+5V Sense+ ^e					N/U		In	
5	+5V Sense- ^e					N/U			
6	I1	RS-485 Data+		N/U	Com+	Carrier+	Note ^f		
7	I1/	RS-485 Data-		N/U	Com-	Carrier-			
8	Temperature+ ^g							In	
9	Temperature- ^g								
10	+5V Source	+8V ^h	+5V Source			N/U		Out	
11	Common					N/U		In/Out	
12	A1	Sine		N/U	Sine	N/U	Sin+	In	
13	A1/	Sine/		N/U	Sine/	N/U	Sin-		
14	B1	Cos		N/U	Cos	N/U	Cos+		
15	B1/	Cos/		N/U	Cos/	N/U	Cos-		
Shell	Shield							N/A	

- a. Supports BiSS Mode B (digital)
- b. An SFD can be connected to F1 or F2, not both
- c. Stegmann Hiperface
- d. Supports Endat 1.1 (Support for Endat 2.1 & 2.2 in future release)
- e. Use of Sense Lines is optional, except if connecting to a Hiperface encoder (see footnote ^h, below)
- f. Pins 6 and 7 are In/Out for Hiperface, Endat, and SFD; Inputs for Digital Incremental and BiSS; and Outputs for Resolver
- g. Temperature inputs (pins 8 and 9) are shared with the F2 connector
- h. Hiperface requires +8Vdc. To supply +8V from pin 10, connect +5V Sense lines (pins 4 & 5) together.

Table 6-6: Pin Description for Feedback Connector (F2)

Signal Type	Signal Name	Notes	Pin
Incremental Encoder Inputs	A1, A1/, B1, B1/, I1, I1/	Differential A quad B encoder signals. These can be defined as inputs or outputs in PiCPro.	12, 13, 14, 15, 6, 7
Emulated F1 Encoder Output	A1, A1/, B1, B1/, I1, I1/	RS485 drivers are used and the signal that is output depends on the encoder or resolver type used. See specifications in section 6.3 on page 151 of this manual. These signals are generated after the feedback from the F1 connector is filtered and processed. These can be defined as inputs or outputs in PiCPro.	12, 13, 14, 15, 6, 7
Motor Commutation Hall Sensor Inputs	S1, S2, S3	Hall-device input signals that are used to initialize the motor commutation angle. They consist of a 74HC14 input with a 10 μ s filter and a 2.2K pull-up to +5V. Shared with F1.	1, 2, 3
SFD Communication Channel	Com+, Com-	SFD communication signals. An SFD can be connected to F1 or F2, not both. An SFD Device can only be connected to F2 if emulated F1 encoder is not used (in which case emulated I and I/ are output on F2 pins 6 & 7).	6, 7
Temperature Input	Temperature	Thermostat (normally- closed) or Thermistor (Phillips KTY84-130 PTC or equivalent recommended) input for detecting over temperature conditions within the motor. These inputs are shared with F1.	8, 9
+5V Encoder Power Output	+5V Source	Regulated +5VDC for powering the attached encoder (200ma max).	10
Signal and Power Common	Common	Return path for feedback signals and +5V power output	11

Table 6-7: Pin Assignments for Feedback Connector (F2)

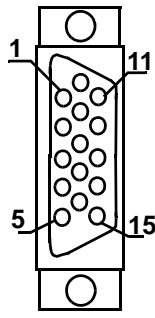
Pin	Signal Name	In/Out	Connector Pinout
1	S1	In	<p>15-pin Female HD D-Sub</p> 
2	S2	In	
3	S3	In	
4	N/U		
5	N/U		
6	I2 (Encoder) Com+ (SFD ^a)	In/Out ^b	
7	I2/ (Encoder) Com- (SFD ^a)	In/Out ^b	
8	Temperature+	In	
9	Temperature-	N/A	
10	+5V	Out	
11	0V	Out	
12	A2	In/Out ^c	
13	A2/	In/Out ^c	
14	B2	In/Out ^c	
15	B2/	In/Out ^c	
Shell	Shield	In	

- a. An SFD can be connected to F1 or F2, not both. An SFD Device can only be connected to F2 if emulated F1 encoder is not used (in which case emulated I and I/ are output on F2 pins 6 & 7).
- b. This pin is an Input when F2 is configured for Encoder Input, an Output when F2 is configured for Emulated Encoder Output, and an Input/Output when F2 is configured for SFD.
- c. This pin is an Input when F2 is configured for Encoder Input, and an Output when F2 is configured for Emulated Encoder Output.

6.1.4.1 Feedback Connectors (F1 and F2) Details

The F1 and F2 Feedback connectors support a variety of devices and functions. This section helps clarify the capabilities and limitations of connected devices.

- The Temperature Inputs are bussed internally between the two feedback connectors F1 and F2. A temperature sensing device can be connected to F1 or F2, but not both.
- Either F1 or F2 can be designated (in PiCPro) as the motor feedback connector.
- F1 can be interfaced to an incremental encoder, sinewave encoder, resolver, or SFD encoder. The signals from the F1 connector are conditioned and can be routed to the F2 connector.
- In PiCPro, the F2 connector can be configured in one of the following modes:
 - To accept Encoder Inputs
 - To provide conditioned Emulated Encoder Outputs derived from the F1 encoder signals
 - To accept SFD feedback device signals
- Hall sensor inputs are only available on the F2 connector
- Refer to [Table 6-8](#) for more information regarding the valid combinations of feedback on the F1 and F2 connectors.

Table 6-8: Supported Feedback Combinations	
Drive Feedback Configuration 1 and 4 (in PiCPro Drive Setup)	
F1 (Motor mounted feedback device for motor control)	F2 (Externally mounted feedback device for position feedback)
<ul style="list-style-type: none"> • Incremental Encoder • Resolver • 1V p-p Sinewave Encoder • Endat 2.1 (single or multi-turn) • Stegmann Hiperface (single or multi-turn) • BiSS (single or multi-turn) • SFD 	<ul style="list-style-type: none"> • Incremental Encoder^a
Drive Feedback Configuration 2 and 3 (in PiCPro Drive Setup)	
F1 (Externally mounted feedback device for position feedback)	F2 (Motor mounted feedback device for motor control)
<ul style="list-style-type: none"> • Incremental Encoder^a • Resolver • 1V p-p Sinewave Encoder • Endat 2.1 (single or multi-turn) • Stegmann Hiperface (single or multi-turn) • BiSS (single or multi-turn) 	<ul style="list-style-type: none"> • Incremental Encoder with halls (Comcoder)^a • SFD

a. The F2 connector can support an Encoder input or Emulated F1 Encoder Output, but not both

Table 6-9: Feedback Port (F1 and F2) to Flying Lead Cable

1 M (3.3 ft): M.3000.1334 3 M (9.8 ft): M.3000.1335
 6 M (19.7 ft): M.3000.1336 9 M (29.5 ft): M.3000.1337
 Cable type: 28 AWG, (1 pair 16 AWG) shielded, twisted pair, 16 conductor.

15-Pin HD male D-sub (to F1/F2 Port, face view)

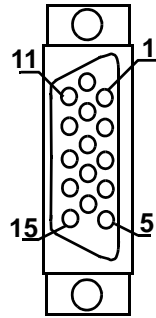

Pin	Signal	Color	Notes
1	S1 ^a	Yellow	Twisted
N/C	N/A	White/Yellow	Pair
2	S2 ^a , RS-485 Clock+	Brown	Twisted
3	S3 ^a , RS-485 Clock-	White/Brown	Pair
4	+5V Sense+	Violet	Twisted
5	+5V Sense-	White/Violet	Pair
6	RS-485 Data+, Com+, Carrier+	Black	Twisted
7	RS-485 Data-, Com-, Carrier-	White/Black	Pair
8	Temperature+	Red	Twisted
9	Temperature-	White/Red	Pair
10	+5V Source	Gray	Twisted
11	Common	White/Gray	Pair ^b
12	Sine/Sin+	Green	Twisted
13	Sine/, Sin-	White/Green	Pair
14	Cos, Cos+	Orange	Twisted
15	Cos/, Cos-	White/Orange	Pair
Shell	Shield	N/A	

a. Hall signals S1, S2, and S3 are only available on F2

b. Pins 10 & 11 are 16 AWG

Description	Length	Part Number
Drive F1/F2 Port Breakout Board ^a	N/A	M.1302.6970
Drive F1/F2 Port Breakout Box ^b	N/A	M.1302.6972
MMC-SDN F1/F2 Port to Breakout Box Cable	1 M (3.3 ft)	M.3000.1330
	3 M (9.8 ft)	M.3000.1331
	6 M (19.7 ft)	M.3000.1332
	9 M (29.5 ft)	M.3000.1333

- a. The Breakout Board (see [Figure 6-3 on page 134](#)) is mounted directly to the F1 and/or F2 connector, and provides screw terminal wire termination. Any combination of breakout board and feedback cable can be used on F1/F2, except a feedback cable on F1 and a breakout board on F2.
- b. The Breakout Box (see [Figure 6-2 on page 134](#)) is DIN-rail mounted, and provides screw terminal wire termination. Use one of the cables listed in the table to connect between the F1 and/or F2 connector and the Breakout Box.

Figure 6-2: Feedback Port (F1 and F2) Breakout Box Dimensions

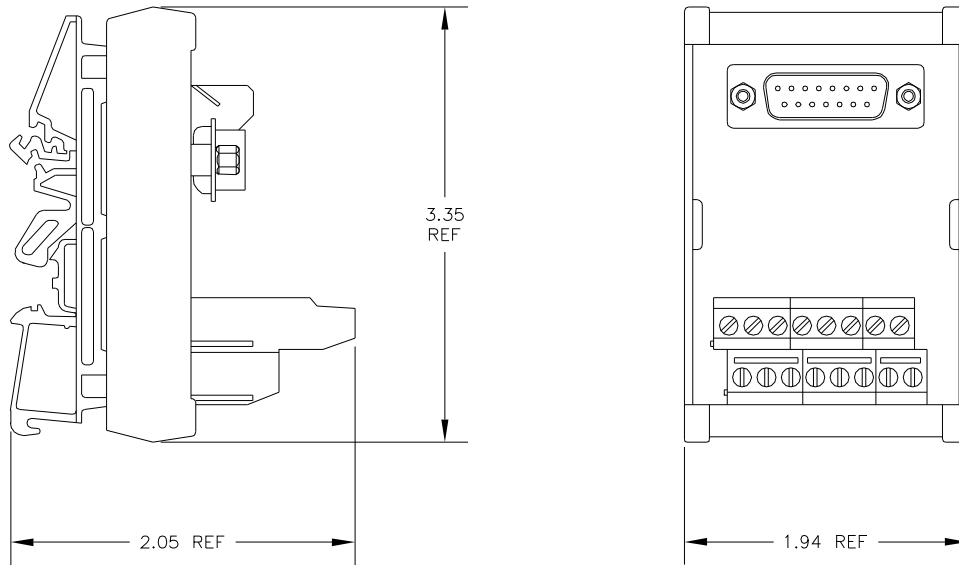

D15 SUB/P
PART NO. M.1302.6972

Figure 6-3: Feedback Port (F1 and F2) Breakout Board Dimensions

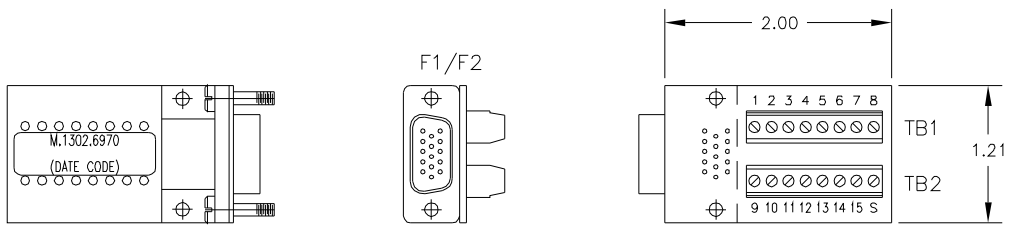

DANAHER MOTION PART NUMBER	DANAHER MOTION SHORT DESCRIPTION
M.1302.6970	BKOUT BD,F1/F2,MMC-SD DR MT

6.1.4.2 Feedback Port (F1/F2) to Motor Cables

Cables are available that allow easy connection between the F1 & F2 Feedback Ports and various Kollmorgen motors. These cables are outlined in [Table 6-11](#). The wiring diagram for each cable is located in the indicated Table. For information on Non-Flex versus Hi-Flex cables, refer to [section 10.1 on page 287](#).

Table 6-11: F1/F2 to AKM/DDR Motor Cables^a			
Feedback	Non-Flex P/N	Hi-Flex P/N	Wiring Diagram
Incremental Encoder	Not Available	CF-CB7374N-XX-0	Table 6-12 on page 136
Endat/BiSS ^b	VF-SB4474N-XX	CF-SB7374N-XX-0	Table 6-13 on page 137
Resolver ^b	VF-RA2474N-XX	CF-RA2574N-XX-0	Table 6-14 on page 138
SFD	VF-DA474N-XX	CF-DA0374N-XX-0	Table 6-15 on page 139

a. "XX" in the above table denotes the length of the cable, in meters. Standard "XX" values are 01, 03, 06, 09, and 12. Hi-Flex cables are available in additional lengths. Consult Kollmorgen for more information.

b. Feedback type not available on F2

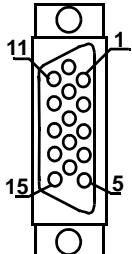
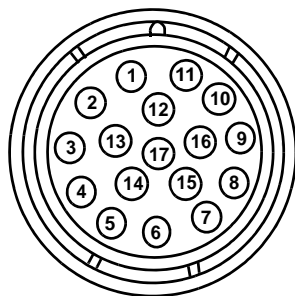
Table 6-12: Feedback Port (F1/F2) Encoder to AKM/DDR Motor				
For Part Numbers, Table 6-11 on page 135				
Twisted Pair 24 AWG (Except as noted)	D-sub 15-Pin HD Male Connector to MMC Smart Drive		Connector to Motor	
				
Wire Color	Pin Number	Signal Type	Pin Number	Signal Type
Yellow	12	A	3	A
Yellow/Black	13	A/	4	A/
Brown	14	B	1	B
Brown/Black	15	B/	2	B/
Orange	6	I	5	I
Orange/Black	7	I/	6	I/
Green	1	S1 ^a	15	S1
Black	2	S2 ^a	16	S2
White	3	S3 ^a	17	S3
Blue	8	Temperature+	8	Temperature+
Blue/Black	9	Temperature-	9	Temperature-
Grey	4	+5V Sense+	10 ^b	+5V Sense+
Grey/Black	5	+5V Sense-	7 ^c	+5V Sense-
Red ^d	10	+5 VDC	10 ^b	+5 VDC
Inner Braid ^d	11	COM	7 ^c	COM
Outer Braid	Shell	Shield	Shell	Shield
N/C		N/A	11-14	N/C

a. Only applicable to F2 connector

b. There are two wires in pin10

c. There are two wires in pin 7

d. This wire is 22 AWG

Table 6-13: Feedback Port (F1) Endat/BiSS to AKM/DDR Motor

For Part Numbers, [Table 6-11 on page 135](#)

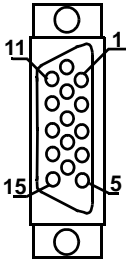
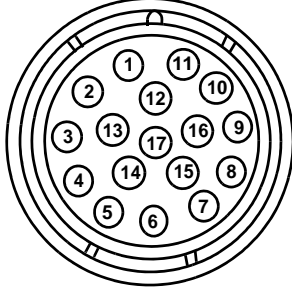
Twisted Pair 28 AWG (Except as noted)	D-sub 15-Pin HD Male Connector to MMC Smart Drive		Connector to Motor	
				
Wire Color	Pin Number	Signal Type	Pin Number	Signal Type
Green	12	Sine	11	Sine
White/Green	13	Sine/	3	Sine/
Blue	14	Cos	9	Cos
White/Blue	15	Cos/	1	Cos/
Red	6	RS-485 Data+	5	RS-485 Data+
White/Red	7	RS-485 Data-	13	RS-485 Data-
Black	2	RS-485 Clock+	8	RS-485 Clock+
White/Black	3	RS-485 Clock-	15	RS-485 Clock-
Yellow	8	Temperature+	7	Temperature+
White/Yellow	9	Temperature-	14	Temperature-
Orange ^a	4	+5V Sense+	4 ^b	+5V Sense+
White/Orange ^a	5	+5V Sense-	2 ^c	+5V Sense-
Grey ^d	10	+5 VDC	4 ^b	+5 VDC
White/Grey ^d	11	COM	2 ^c	COM
Outer Braid	Shell	Shield	Shell	Shield
N/A	N/A	N/A	6,10,12,16,17	N/C
N/A	1	N/C	N/A	N/A

- a. This wire is 22 AWG
- b. There are two wires in pin 4
- c. There are two wires in pin 2
- d. This wire is 16 AWG

Table 6-14: Feedback Port (F1) Resolver to AKM/DDR Motor

For Part Numbers, [Table 6-11 on page 135](#)

Wire Color	Pin Number	Signal Type	Connector to Motor	
			Pin Number	Signal Type
Yellow	12	Sin+	8	Sin+
White/Yellow	13	Sin-	4	Sin-
Blue	14	Cos	7	Cos
White/Blue	15	Cos-	3	Cos-
Black	6	Carrier+	9	Carrier+
White/Black	7	Carrier-	5	Carrier-
Red	8	Temperature+	2	Temperature+
White/Red	9	Temperature-	6	Temperature-
Outer Braid	Shell	Shield	Shell	Shield
N/A	N/A	N/A	1,10-12	N/C
N/A	1-5,10,11	N/C	N/A	N/A

Twisted Pair
28 AWG

D-sub 15-Pin HD Male
Connector to MMC Smart
Drive

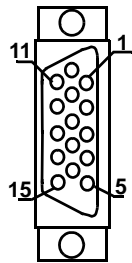

Connector to Motor

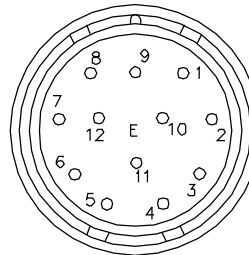
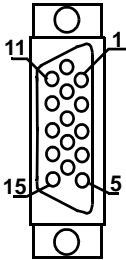
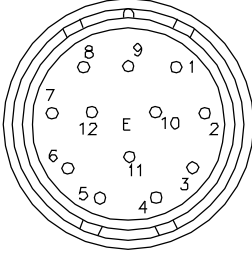

Table 6-15: Feedback Port (F1/F2) SFD to AKM/DDR Motor

For Part Numbers, [Table 6-11 on page 135](#)

Wire gauge as noted	D-sub 15-Pin HD Male Connector to MMC Smart Drive		Connector to Motor	
				
Wire Color	Pin Number	Signal Type	Pin Number	Signal Type
Red ^a	10	+5V Source	1	+5V Source
Drain ^a	11	Common	2	Common
Green ^b	7	Com-	3	Com-
White ^b	6	Com+	4	Com+
Inner Braid	N/C	N/A	5	Shield
Outer Braid	Shell	Shield	Shell	Shield
N/A	N/A	N/A	6-12	N/C
N/A	1-5,12-15	N/C	N/A	N/A

a. This wire is 22 AWG

b. This wire is 24 AWG

6.1.5 Drive I/O Connectors (IO1 & IO2)

The two 10-pin pluggable screw-terminal connectors (labeled “IO1” and “IO2” on the front of the Drive) provide connection between various devices and the Drive. These connectors provide one Analog Input, one Analog Output, two Fast Inputs, a relay output, six General Purpose Inputs, and two General Purpose Outputs (wiring example shown in [See Figure 6-4 on page 143](#)).

- Pin descriptions are provided in [Table 6-16](#)
- Pin assignments are provided in [Table 6-17](#)

Table 6-16: Pin Description for Drive I/O Connectors (IO1 & IO2)

Signal Type	Notes	IO1 Pins	IO2 Pins
Analog Input	Analog Input of -10VDC to +10VDC	1, 2	
Analog Output	Analog Output of -10VDC to +10VDC	2, 3	
General Purpose Software Assignable Outputs	24VDC sourcing type	5, 6	
General Purpose Output power	24 VDC input for powering GPOUTs	7, 8	
Relay Output	Mechanical Relay Output	9, 10	
Fast Inputs	24VDC (nominal) Inputs, configurable as Sinking or Sourcing. Used for latching encoder position.		1, 2
Fast Input Sink/Source	This pin determines whether the Fast Inputs are sourcing (this pin connected to 24 Vdc) or sinking (this pin connected to 24 Vdc Common)		3
General Purpose Software Assignable Inputs	24VDC (nominal) Inputs, configurable as Sinking or Sourcing		4, 5, 6, 7, 8, 9
General Purpose Inputs Sink/Source	This pin determines whether the General Purpose Inputs are sourcing (this pin connected to 24 Vdc) or sinking (this pin connected to 24 Vdc Common)		10

Table 6-17: Pin Assignment for Drive I/O Connectors (IO1 & IO2)

Connector IO2				Connector IO1				Connector Pinout
Pin	Wiring Label	PiCPro I/O Label	In/Out	Pin	Wiring Label	PiCPro I/O Label	In/Out	
1	FASTIN1	Input 7	In	1	Analog In-	Analog Input	In	Dual 10-pin Pluggable Screw-terminal Connector
2	FASTIN2	Input 8	In	2	Analog In+		In	
3	FASTIN Sink/Source		In	3	Analog Out	Analog Output	Out	
4	GPIN1	Input 1	In	4	Analog Out Return		In	
5	GPIN2	Input 2	In	5	GPOUT1	Output 1	Out	
6	GPIN3	Input 3	In	6	GPOUT2	Output 2	Out	
7	GPIN4	Input 4	In	7	GPOUT 24VDC		In	
8	GPIN5	Input 5	In	8	GPOUT 24VDC Return		In	
9	GPIN6	Input 6	In	9	Relay	Output 3	Out	
10	GPIN Sink/Source		In	10			Out	

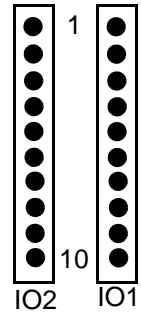
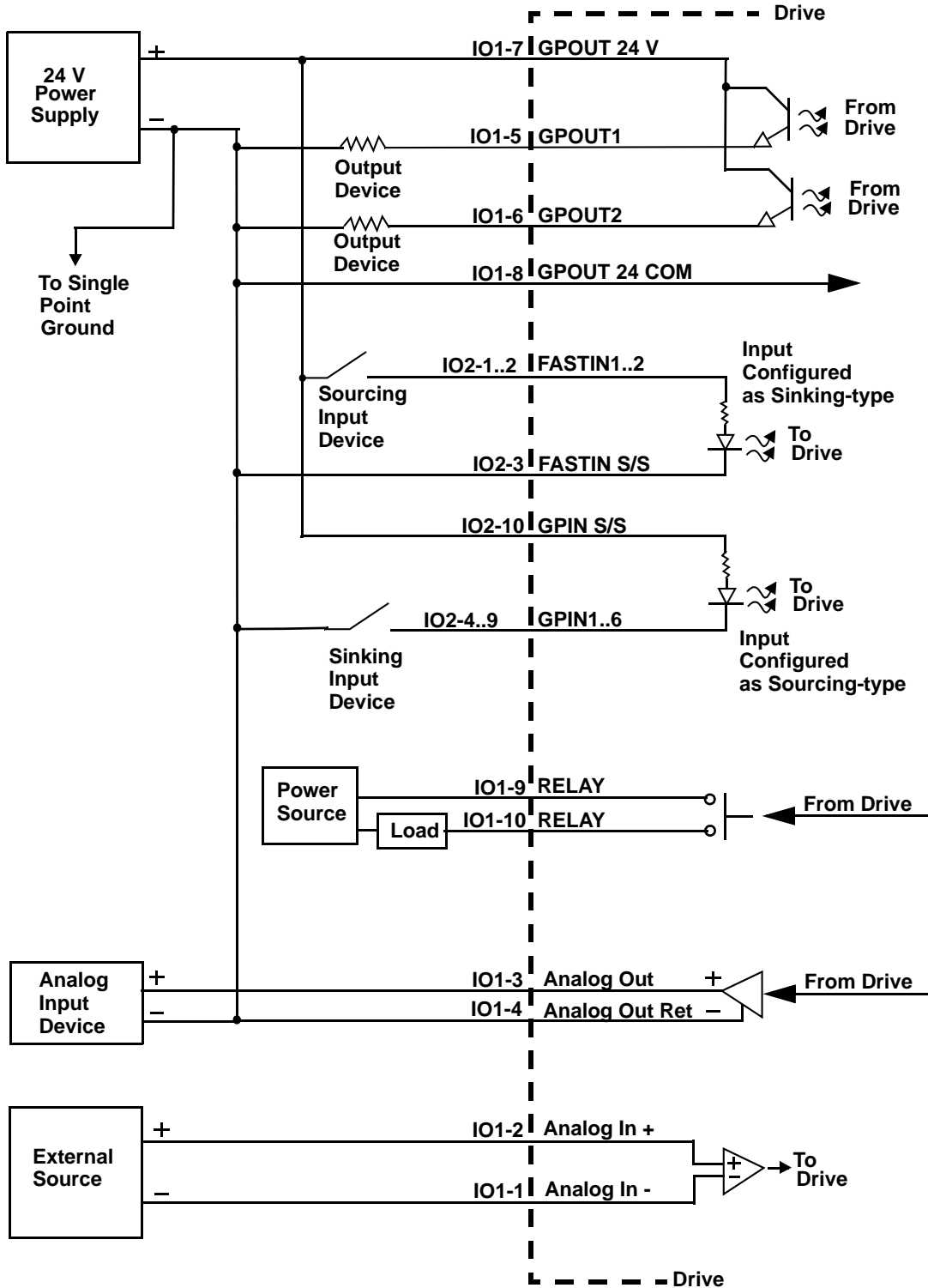

Figure 6-4: Wiring Diagram for Drive I/O Connectors (IO1 & IO2)



6.2 Power Section Connectors

This section describes the connectors located on the Power Section (left portion) of the drive.

6.2.1 DC Power Connector

The DC Power Connector consists of a plugable 3-pin screw-terminal block, and provides +24VDC (nominal) Logic Power to the drive, as well as the "Safe Torque Off" Enable signal.

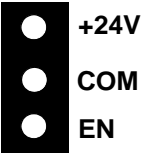
Terminal Label	Signal Type	Signal Description	PiCPro I/O Label	In/Out	Connector Pinout
+24V	Logic Power	+24V user supplied power signal terminal.	N/A	In	3-pin Plugable Screw Terminal 
COM	Common	+24V Common	N/A	In	
EN	Drive Enable	Safe-off Signal. (See section 6.2.1.1 on page 144).	N/A	In	

6.2.1.1 "EN" requirements and Safe-off Operation

The Drive contains Safe-off capability. **The "EN" pin located on the 3-pin DC PWR connector must have 24Vdc applied to it in order for the drive to operate.**

The following two sections describe the behavior of Safe-off function.

6.2.1.1.1 "EN" Operation

The Drive will only perform a Safe-off fault if the following two conditions are met:

- The drive is enabled by the application
- The "EN" input pin is not at 24Vdc

The general sequence of operation of the Safe-off function is as follows:

1. An external user-supplied circuit provides 24Vdc to the "EN" input
2. The drive is enabled via the Application Program
3. The application controls the motor as desired
4. The drive is disabled via the Application Program
5. The external user-supplied circuit removes 24Vdc from the "EN" input
6. The process is repeated starting with step 1 above as required

If during step 3 above, the user-supplied external circuitry removes 24Vdc from the "EN" input (usually due to a safety violation on the equipment being controlled), the drive will fault, and the motor will coast to a stop. The drive must be powered off and back on to remove the fault condition.

6.2.2 AC Power Connector

The Power Connector consists of a pluggable 4-pin screw-terminal block, and provides connection to the incoming AC power.

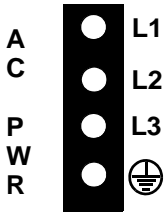
Terminal Label	Signal Type	Signal Description	In/Out	Pin Sequence
L1	AC Power	200-480VAC three-phase power in to drive. ^a	In	4-pin Pluggable Screw Terminal
L2				
L3				
	Protective Ground	Must be connected to Protective Earth Ground (SPG).	In	

a. May also be used with 100-200VAC, 1 or 3 phase, with limited output capability

SINGLE PHASE CONNECTION
If single-phase power is used, L1 must be connected to "hot", and L2 must be connected to "neutral". L3 may remain unconnected.

6.2.2.1 Line Fusing

See [Table 6-20](#) for information on recommended fuses and holders. See [section 4.2 on page 40](#) for additional information on Drive Protection.

Table 6-20: Recommended Fuses & Holders

For Drive Model	Combination Fuse	Fuse Part Number	Fuse Holder Type 3P	Fuse Holder Part Number
MMC-SDN-1.8-460	DFJ6	M.3000.0190	30 Amp	M.1016.1046
MMC-SDN-3.6-460	DFJ10	M.3000.1321	30 Amp	M.1016.1046
MMC-SDN-7.2-460	DFJ15	M.3000.0191	30 Amp	M.1016.1046
MMC-SDN-14.4-460	DFJ30	M.3000.0194	30 Amp	M.1016.1046

6.2.3 Motor/Brake Connector

The Motor/Brake Connector consists of a pluggable 6-pin screw-terminal block, and provides connection to the motor and the motor brake that is being controlled by the Drive.

Table 6-21: Pin Assignment for Motor/Brake Connector

Terminal Label	Signal Type	Signal Description	In/Out	Pin Sequence
-BR	Brake Relay -	Motor brake control ^a	In	6-pin Pluggable Screw Terminal
+BR	Brake Relay +		Output3	
⊕	Protective Ground	Must be connected to Protective Earth Ground (SPG).	In	
U	Motor Power	Power U-phase from the drive to the motor.	Out	
V		Power V-phase from the drive to the motor.	Out	
W		Power W-Phase from the drive to the motor.	Out	

a. This output can be defined and used as a General Purpose Output in PiCPro (Output3), but is typically defined as the Motor Brake Control.

NOTE
Use of a diode (as shown) or an external RC type snubber is highly recommended for use with inductive loads, especially DC inductive loads.

Figure 6-5: BR+ and BR- Wiring Examples

Using External Power Source

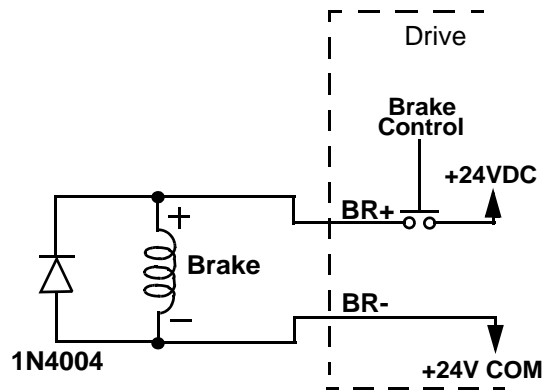

6.2.3.1 Motor/Brake Cables

Cables are available that allow easy connection to the between the Motor Power connector and Kollmorgen AKM/DDR motors. These cables are outlined in [Table 6-22](#). For a detailed description of these cables, refer to the Kollmorgen “AKD/S700 Accessories Manual” which can be found at www.kollmorgen.com. For information on Non-Flex versus Hi-Flex cables, refer to [section 10.1 on page 287](#).

Drive	Non-Flex P/N	Non-Flex (w/ brake) P/N ^a	Hi-Flex P/N ^a	Hi-Flex (w/ brake) P/N ^a
MMC-SDN-1.8-460-D MMC-SDN-3.6-460-D	VP-507BEAN-XX	VP-508CFAN-XX	CP-507CCAN-XX	CP-507CDAN-XX
MMC-SDN-7.2-460-D	VP-508CEAN-XX	VP-508CFAN-XX	CP-507CCAN-XX	CP-507CDAN-XX
MMC-SDN-14.4-460-D	VP-508DEAN-XX	VP-508DFAN-XX	CP-508EBDN-XX	CP-508EBDN-XX

a. "XX" in the above table denotes the length of the cable, in meters. Standard "XX" values are 01, 03, 06, 09, and 12. Hi-Flex cables are available in additional lengths. Consult Kollmorgen for more information.

6.2.3.2 Motor Chokes

If a motor cable over 25 meters is used, a Motor Choke must be installed. These chokes are outlined in [Table 6-23](#). For a detailed description of these chokes, refer to the Kollmorgen “AKD/S700 Accessories Manual” which can be found at www.kollmorgen.com.

Drive	Choke Part Number
MMC-SDN-1.8-460-D MMC-SDN-3.6-460-D	3LYN-06
MMC-SDN-7.2-460-D	3LYN-14
MMC-SDN-14.4-460-D	3LYN-24

6.2.4 DC Bus/Regen Connector

The DC Bus/Regen Connector consists of a pluggable 4-pin screw-terminal block, and provides connection to the drives DC Bus and to an external Regen resistor.

ADDITIONAL SHUNT RESISTOR INFORMATION
Refer to section 4.5 on page 58 for instructions on choosing, mounting, and connecting Shunt Resistors available from Kollmorgen.

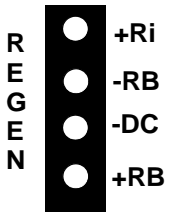
Terminal Label	Signal Description	In/Out	Pin Sequence
+Ri	Internal Regen resistor	Out	4-pin Pluggable Screw Terminal 
-RB	Regen Resistor Control	Out	
-DC	-DC Bus Output	Out	
+RB	+DC Bus Output	Out	

6.2.4.1 Bus/Regen Connections

Use the following guidelines when making connections to the Bus/Regen Connector:

- To use the Regen resistor contained within the Drive, connect +Ri to -RB with a jumper
- To use an external Regen resistor, connect the resistor between +RB and -RB
- To use DC Bus Sharing between the Drive and one or more additional drives:
 - Connect +RB to the connected drive's +DCBUS
 - Connect -DC to the connected drive's -DCBUS

6.2.4.2 External Regen Resistors

Although an internal regen resistor is contained within each Drive, there may be applications that require an external regen resistor. Available external regen resistors are outlined in [Table 6-25](#). For a detailed description of these resistors, including mounting information, refer to the Kollmorgen “AKD/S700 Accessories Manual” which can be found at www.kollmorgen.com.

Table 6-25: External Regen Resistors		
For Drive	Shunt Resistor Module	Part Number
MMC-SDN-1.8-460-D MMC-SDN-3.6-460-D MMC-SDN-7.2-460-D	33Ω, 100W Cont. Power, 160W Peak Power	BAFP-100-33
	33Ω, 200W Cont. Power, 320W Peak Power	BAFP-200-33
	33Ω, 250W Cont. Power, 400W Peak Power	BAR-250-33
	33Ω, 500W Cont. Power, 800W Peak Power	BAR-500-33
	33Ω, 1.5kW Cont. Power, 2.4kW Peak Power	BAR-1500-33
	33Ω, 3kW Cont. Power, 4.8kW Peak Power	BAR-3000-33
MMC-SDN-14.4-460-D	23Ω, 600W Cont. Power, 960W Peak Power	BAR-600-23
	23Ω, 1kW Cont. Power, 1.6kW Peak Power	BAR-1000-23
	23Ω, 2kW Cont. Power, 3.2W Peak Power	BAS-2000-23
	23Ω, 3kW Cont. Power, 4.8kW Peak Power	BAS-3000-23
	23Ω, 4kW Cont. Power, 6.3kW Peak Power	BAS-4000-23

6.3 Specifications - 460V MMC Smart Drive NextGen

6.3.1 General Data

General Drive Data	
Minimum wire size for AC PWR, REGEN, and MOTOR connectors	3A & 6A Drives: 1.5mm ² (16 AWG), 75° C copper. 12A Drive: 2.5mm ² (14 AWG), 75° C copper. 24A Drive: 4mm ² (12 AWG), 75° C copper.
Minimum wire characteristics for AC PWR, REGEN, and MOTOR connectors	AC PWR: 600V, 75° C, copper REGEN: 1,000V, 75° C, copper, shielded MOTOR: 600V, 75° C, copper, shielded, C <150 pF/m
Recommended tightening torque for AC PWR, REGEN, and MOTOR connectors	7 in-lbs
Recommended tightening torque for DC PWR connector	4 in-lbs
Recommended tightening torque for Drive I/O connectors	2 in-lbs
Commutation	Three Phase Sinusoidal
Current Regulator	Digital PI 125 µsec. update rate
Velocity Regulator	Digital PID - 250 µsec. update rate
Environmental Data	
Operating Temperature Range (Surrounding Air)	0° C to 40° C (32° F to 104° F). Derate output 4% per 4° C (1.8° F) from 40° C to 55° C (104° F to 131° F)
Storage Temperature Range	-25° C to 55° C (-13° F to 131° F)
Transport Temperature Range	-25° C to 70° C (-13° F to 158° F)
Humidity	5% to 85% non-condensing
Altitude	1,000 m (3,281ft) Derate 1.5%/100m from 1,000m to 2,500m
Pollution	Pollution level 2 per IEC 60644-1
Vibration Limits (per IEC 68-2-6) Operating/Non-operating	10-57 Hz (constant amplitude.15 mm) 57 - 2000 Hz (acceleration 2 g)
Shock (per IEC 68-2-27) Non-operating	Four shocks per axis (15g/11 msec)

Conformity	
CE Marked (pending).	Conforms to Low Voltage Directive 73/23/EEC (amended by 93/68/EEC) and EMC Directive 89/336/EEC (amended by 92/31/EEC and 93/68/EEC). Conformance is in accordance with the following standards: EN 50178 and EN61800-3
UL and C/UL Listed	E233454
DC Input Power Specifications (24VDC)	
Input Voltage Range	24 VDC +/-10%
Typical Input Current (does not include Brake Output current)	1A (3A, 6A, and 12A Drives), 2A (24A Drive)
Typical Input Wattage	15.6 W
Inrush Current	Not Specified
F1 and F2 Feedback Inputs	
Input receiver type	Maxim 3098 A quad B differential RS422 receiver
Encoder signals	Differential quadrature
Input threshold	±200 mV
Input termination	150Ω, provided internally
Maximum input voltage	5V peak to peak differential -10 to +13.2V common mode
Maximum input signal frequency	720 K Hz (2.88 M feedback counts per second)
+5V regulated output	F1 = 350ma, F2 = 200ma

F2 Connector Encoder Emulation Output	
<p>Note: The F2 connector can be configured provide an emulated Output of the encoder connected to F1, as described below. When so configured, a feedback device (Incremental Encoder or SFD), cannot be connected to F2.</p>	
F1 Motor Feedback Type	<ul style="list-style-type: none"> • Input Limit • Maximum Encoder Emulation Output Rate • Emulated Output Description
Incremental Encoder	<ul style="list-style-type: none"> • 720 KHz • 2.88 M counts/sec. • The motor encoder A/B/I inputs are electrically buffered and can be retransmitted out of the F2 connector.
High Resolution Encoder SFD	<ul style="list-style-type: none"> • 100 KHz • 400 K counts/sec. • The encoder SIN/COS signals are electrically squared and retransmitted as A/B. The index mark "I" is synthesized by the Drive. Absolute position information is not available via the Encoder Emulation Output.
Resolver	<ul style="list-style-type: none"> • 500 RPS • 2.00 M counts/sec. • The resolver inputs are converted to 4096 lines/16384 counts per revolution of A/B encoder output. The Drive synthesizes the index mark "I" once per revolution of the resolver. Absolute position information is not available via the Encoder Emulation Output.
General Purpose Inputs	
Configuration	<ul style="list-style-type: none"> • 6 optically isolated 24V DC Inputs • Sink or Source in group of 6 • 2 optically isolated 24V DC Fast Inputs • Sink or Source in group of 2
Guaranteed On	15 VDC
Guaranteed Off	5 VDC
Time delay on	1 ms max. (3us for Fast Inputs)
Time delay off	1 ms max (50us for Fast Inputs)
Input voltage	Nominal 24 VDC, maximum 30 VDC

EN (Safe-off) Input	
Configuration	24Vdc (nominal) = Drive Enabled
Guaranteed On	15 VDC
Guaranteed Off	5 VDC
Input Current, Typical	25mA.
General Purpose Outputs	
Configuration	<ul style="list-style-type: none"> • 2 optically isolated 24V DC outputs • Active high • Current sourcing only (current into load) • Short circuit and overload protected
Maximum current	50mA per output
Voltage range	24VDC +15%-10%
Time delay on for resistive loads	50 μ sec. max
Time delay off for resistive loads	50 μ sec. max
Leakage current in off state	0.5 mA max
Relay Output (on Control Board)	
Configuration	Normally Open mechanical contact
Maximum current	2A
Voltage range	24VDC +/-10%
Time delay on for resistive loads	3 msec. max
Time delay off for resistive loads	5 msec. max
Brake Control Output (on Power Board)	
Configuration	Solid State Switch
Maximum current	1.5A (3A, 6A, 12A Drive), 2A (24A Drive)
Voltage range	24VDC +/-10%
Time delay on for resistive loads	50 μ sec. max
Time delay off for resistive loads	50 μ sec. max

General Purpose Analog Input	
Input Characteristics	-10VDC to +10VDC 14 bit effective resolution
General Purpose Analog Output	
Output Characteristics	-10VDC to +10VDC 16 bit effective resolution
Digital Link In/Out Ports	
"In" port	Sends and receives high speed data to and from connected MMC-SD's "Out" port.
"Out" port	Sends and receives high speed data to and from connected MMC-SD's "In" port.
Cable Type	Shielded, Straight Pinned, CAT5 or better (CAT5e, CAT6, etc.)
Maximum Cable Length	30 m (98.4 ft)

6.3.2 Physical and Electrical Data

	Model			
	MMC-SDN-1.8-460-D	MMC-SDN-3.6-460-D	MMC-SDN-7.2-460-D	MMC-SDN-14.4-460-D
Part Numbers	M.3000.1300	M.3000.1301	M.3000.1302	M.3000.1303
Weight, lbs (kg)	6.0 (2.7)	6.0 (2.7)	6.0 (2.7)	11.7 (5.3)
AC Input Specifications				
Input Power (kVA)	2.24	4.49	7.65	15.2
Number of Phases	3 ^a			
Input Voltage, VAC	200-480 ^b			
Input Frequency, Hz	47 - 63 ^c			
Input Current Amps RMS	3.5	6	12	23
Maximum Inrush Amps 0-Peak	10	10	10	20
Power Loss, Watts	102	129	153	237
AC Output Specifications				
Note: AC Output is specified at an ambient of 0° C to 40° C (32° F to 104° F). Derate output 4% per 4° C (1.8° F) from 40° C to 55° C (104° F to 131° F)				
Output Current (Amps)				
Continuous RMS	3	6	12	24
Continuous 0-Peak	4.2	8.5	17	34
Peak 0-Peak	12.7	25.5	42.5	67.9
Continuous Output Power				
Input = 240 VAC, KW	0.6	1.25	2.5	5
Input = 400 VAC, KW	1	2	4.2	8.3
Input = 480 VAC, KW	1.2	2.5	5	10

Peak Output Power (for 1Sec)				
Input = 240 VAC, KW	1.8	3.75	6.25	10
Input = 400 VAC, KW	3	6.75	10.4	16.7
Input = 480 VAC, KW	3.6	7.5	12.5	20
Output Frequency, Hz	0-800			
Energy Absorbtion Specifications				
DC Bus Capacitance (Internal)	235 μ F		470 μ F	680 μ F
Bus overvoltage threshold	840 VDC			
Joules available for energy absorption				
400VAC line input	35 joules		70 joules	110 joules
480 VAC line input	20 joules		40 joules	60 joules

- a. May also be used single-phase power, with limited output capability
- b. May also be used with 100-199VAC input power, with limited output capability
- c. May also be used with 64-420Hz input power, with limited output capability

6.4 Dimensions

This section contains dimensional information on the Drives. Use this information to determine mounting hole locations on the drive panel.

When locating the drive on the panel, observe the clearance requirements found in [Table 3-1 on page 21](#). Mount the drive to the panel with #10 bolts and #10 star washers (to ensure proper ground connection).

Figure 6-6: 3, 6, and 12 Amp Drives - Front View

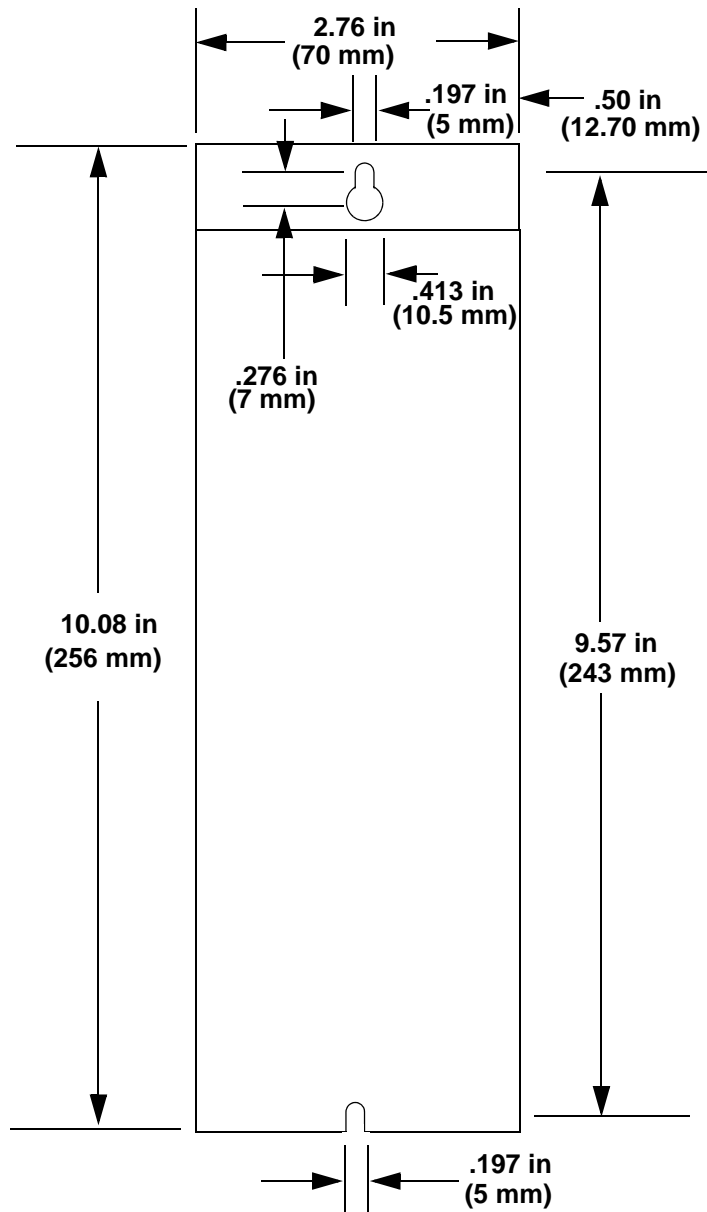

Depth (to front surface of Drive): 7.375" (188mm)

Figure 6-7: 24 Amp Drive - Front

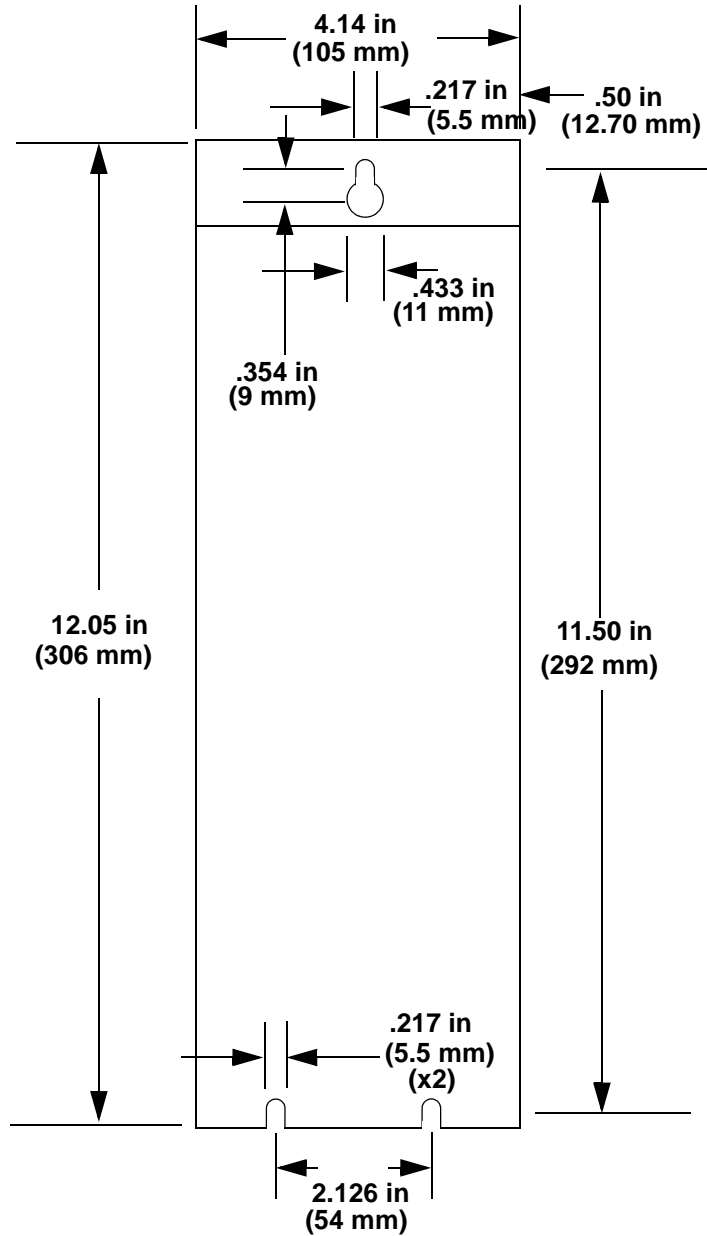

Depth (to front surface of Drive): 9.125" (232mm)

7 230V 1/3 Phase MMC Smart Drive

The 230V MMC Smart Drive is available in both analog and digital interfaced versions, with power ratings from .5kW through 3kW. This section describes these drives in detail.

The following 230V MMC Smart Drive are available:

- Single Phase analog and digital interfaced versions, with power ratings of .5kW, 1kW, and 2kW.
- Three Phase analog and digital interfaced versions, with power ratings of .5kW, 1kW, 2kW, 3kW (digital interfaced only).

Features include:

- 230V, Single Phase drives available with power ratings of .5kW, 1kW, and 2 kW
- 230V, Three Phase drives available with power ratings of .5kW, 1kW, 2 kW, and 3 kW
 - Can also operate on Single Phase power
 - Built-in Regen circuitry (requires external Regen resistor)
 - Optional Safe-off feature
- Drive firmware in user upgradeable Flash memory
- Serial port for communications with PC-resident PiCPro
- Internal switch to control a mechanical brake
- Green Power LED and yellow Diagnostic LED
- A primary feedback connector (F1), containing the following features:
 - High density female DB-15 connector
 - Supports the following feedback devices:
 - Incremental Encoder (without halls, Enhanced Feedback models only)
 - Comcoder Input (Incremental Encoder with halls, not on Enhanced Feedback models). Note that halls can be connected to F1 or F2, but not both.
 - Stegmann Hiperface encoder
 - High Resolution Resolver
 - 1V p-p Sinewave Encoder
 - Endat 2.1 (2.2 in future release)
 - BiSS (Mode B)
- A secondary feedback connector (F2), containing the following features:
 - High density female DB-15 connector
 - This connector can support one of the following functions:
 - Emulated F1 encoder output
 - Comcoder Input (Incremental Encoder with halls). Note that on non-Enhanced Feedback models, halls can be connected to F1 or F2, but not both.

- Eight General Purpose 24VDC Inputs
- Four General Purpose 24VDC outputs
- $\pm 10V$ Analog Input
 - Command Input (Analog Interfaced MMC-SD only)
 - General purpose Analog Input (Digital MMC-SD only)
- Digital Link digital connections (Digital MMC-SD only)
- Optional MMC-SD Control (for Digital MMC-SD only)
- UL Listed and CE Marked.

Figure 7-1: Front Panel, 230V Drives

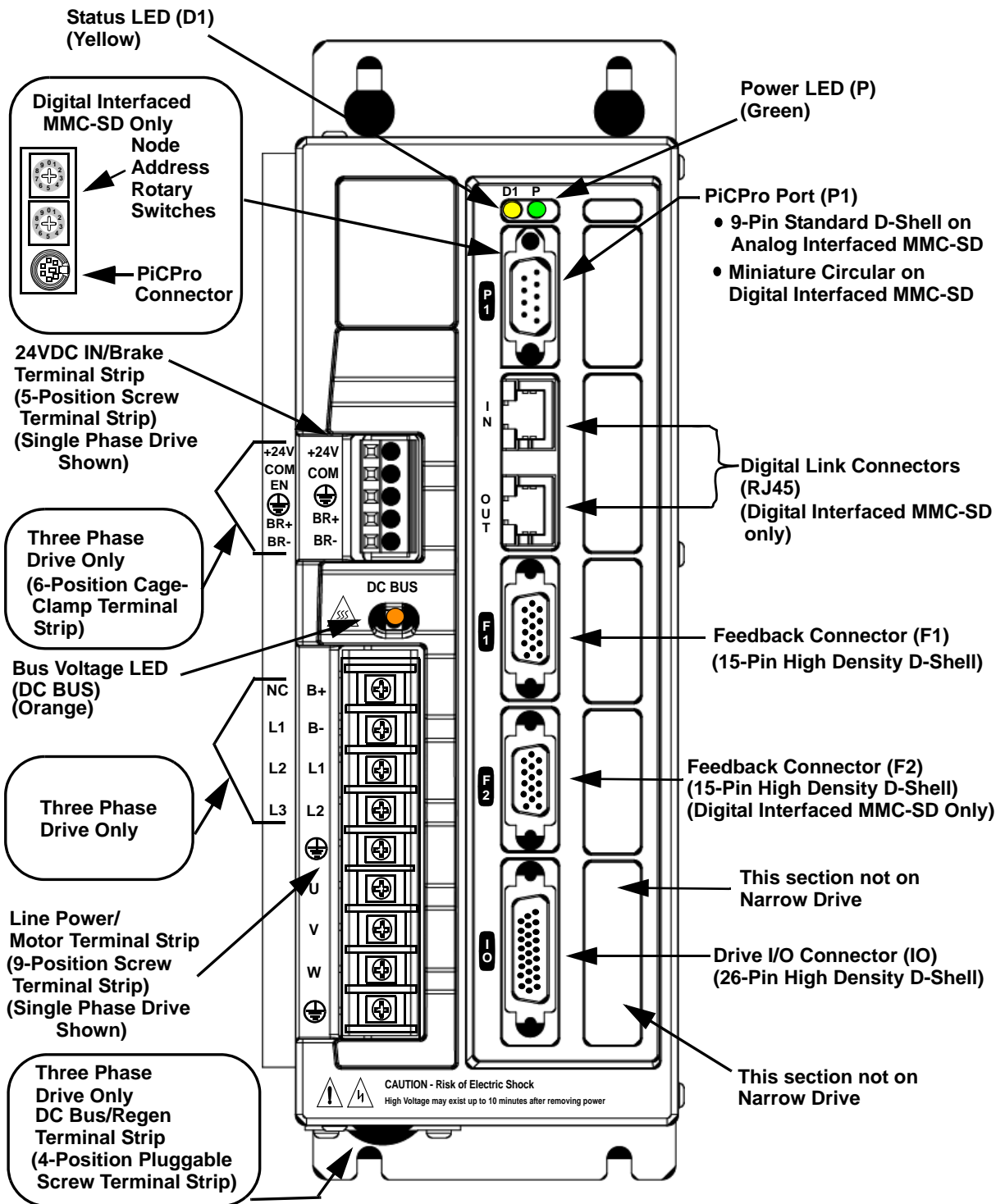

7.1 Control Section Connectors, Switches, LEDs

This section describes the connectors, switches, and LEDs located on the Control Section (right portion) of the drive.

NOTE
The functionality and descriptions for the switches, connectors, and LEDs on the control section of the 460V MMC Smart Drives are the same as those on the 230V MMC Smart Drive.

7.1.1 LEDs

Table 7-1: LEDs Description for 230V MMC Smart Drive

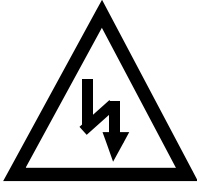
LED	Color	Description
P	Green	Power LED. Indicates when illuminated that power is being supplied to the 24V input terminal strip.
D1	Yellow	Status LED. Drive status and fault information.
<p style="text-align: center;">DC BUS</p> 	Orange	<p>Bus Voltage LED. Indicates when illuminated that the DC bus is at a hazardous voltage (not available on 460V Smart Drives).</p> <p>DANGER DC bus capacitors may retain hazardous voltages for up to ten minutes after input power has been removed. Always use a voltmeter to ensure that the DC bus voltage is below 50VDC before servicing the drive. Failure to observe this precaution could result in severe bodily injury or loss of life.</p>

7.1.2 PiCPro Port (Digital Interfaced Drives)

This section details the PiCPro Port connector on the Digital Interfaced Drives (-D and -DN). For information on the PiCPro Port connector on Analog Interfaced Drives, see [section 7.1.3 on page 166](#).

The 6-pin circular DIN PiCPro Port connector (labeled "P1" on the front of the Drive) provides serial communication for the PiCPro programming interface.

- Pin descriptions for are provided in [Table 7-2](#)
- Pin assignments are provided in [Table 7-3](#)
- The available PiCPro Port to PC cable is described in [Table 7-4](#)

USB ADAPTER
<p>A USB-to-RS232 Adapter is available (P/N M.3000.0879) that allows you to connect the PiCPro Port on the Control to a USB connector on your PC. One side of the Adapter contains a 6in cable that connects to your PC. The other side of the Adapter contains a male DB9 connector that allows connection to the Control using a PiCPro Cable M.1302.8250 (not provided, described in Table 7-7 on page 169).</p>

Table 7-2: PiCPro Port Pin Descriptions

Function	Notes	Pin
Receive Data	RS232-level signal that receives serial data from the connected PC running PiCPro.	1
Transmit Data	RS232-level signal that transmits serial data to the connected PC running PiCPro.	2
Signal Ground	Provides the return path for signals	3 and 5
Shield Ground	Provides a path for shield current through the chassis to an external single point ground.	Connector Shell

Table 7-3: PiCPro Port Pin Assignments

Pin	Signal	In/Out	Connector Pinout
1	RS232 Receive Data	In	<p style="text-align: center;">6-pin Female Miniature Circular DIN</p> 
2	RS232 Transmit Data	Out	
3	Signal Ground	In/Out	
4	NC	N/A	
5	Signal Ground	In/Out	
6	NC	N/A	
Connector Shield	Shield	In	

Table 7-4: PiCPr0 Port to PC Cable

Part Number: M.1302.8284 Length: 4 M (13 ft) Cable type: 24 AWG, shielded, twisted pair, 4 conductor.				
6-Pin male Miniature Circular DIN (to PiCPro Port, face view)		9-Pin female D-sub (to PC COM Port, face view)		
				
Pin	Signal	Pin	Signal	Notes
1	RS232 Receive Data	3	RS232 Transmit Data	Twisted Pair
2	RS232 Transmit Data	2	RS232 Receive Data	
5	Signal Ground	5	Signal Ground	
Shell	Drain	Shell	Drain	

7.1.3 PiCPro Port (Analog Drives)

This section details the PiCPro Port connector on the Analog Interfaced Drives (not -D or -DN). For information on the PiCPro Port connector on Digital Interfaced Drives, see [section 7.1.2 on page 164](#).

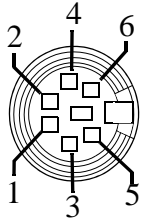
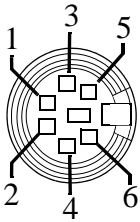
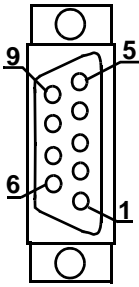
The 9-pin male D-sub PiCPro Port connector (labeled “P1” on the front of the Drive) provides serial communication for the PiCPro programming interface.

- Pin descriptions for are provided in [Table 7-5](#)
- Pin assignments are provided in [Table 7-6](#)
- The available PiCPro Port to PC cable is described in [Table 7-7](#)

USB ADAPTER
<p>A USB-to-RS232 Adapter is available (P/N M.3000.0879) that allows you to connect the PiCPro Port on the Control to a USB connector on your PC. One side of the Adapter contains a 6in cable that connects to your PC. The other side of the Adapter contains a male DB9 connector that allows connection to the Control using a PiCPro Cable M.1302.8250 (not provided, described in Table 7-7 on page 169).</p>

Function	Notes	Pin
Receive Data	RS232-level signal that receives serial data from the connected PC running PiCPro.	2
Transmit Data	RS232-level signal that transmits serial data to the connected PC running PiCPro.	3
Signal Ground	Provides the return path for signals	5
Data Terminal Ready	Always high (tied to +12V through 1K resistor)	4
Request-to-send	Always high (tied to +12V through 1K resistor)	7
Shield Ground	Provides a path for shield current through the chassis to an external single point ground.	Connector Shell

Table 7-6: PiCPro Port Pin Assignments

Pin	Signal	In/Out	Connector Pinout
1	NC	N/A	<p>9-pin male D-sub</p>  <p>The diagram shows a 9-pin male D-sub connector. The pins are arranged in a vertical row. Pin 1 is at the top right, pin 5 is at the bottom right, pin 6 is at the top left, and pin 9 is at the bottom left. The connector has a shield at the top and bottom.</p>
2	RS232 Receive Data	In	
3	RS232 Transmit Data	Out	
4	Data Terminal Ready	Out	
5	Signal Ground	In/Out	
6	NC	N/A	
7	Request-to-send	Out	
8	NC	N/A	
9	NC	N/A	
Connector Shield	Drain	In	

Table 7-7: PiCPr0 Port to PC Cable

Part Number: M.1302.8250 Length: 4 M (13 ft) Cable type: 24 AWG, shielded, twisted pair, 4 conductor.				
9-Pin female D-sub (to PiCPro Port, face view)		9-Pin female D-sub (to PC COM Port, face view)		
Pin	Signal	Pin	Signal	Notes
2	Receive Data	3	Transmit Data	Twisted Pair
3	Transmit Data	2	Receive Data	
5	Signal Ground	5	Signal Ground	
Shell	Drain	Shell	Drain	

7.1.4 Node Address Rotary Switch (Digital Interfaced MMC-SD Only)

Two rotary switches are used to set the drive address. Rotate the switch to the desired address.

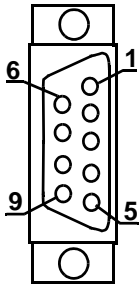
Addresses can be set to any number from 1 through 64. The top switch represents values of base ten. The bottom switch represents values of base 1.

As an example, rotating the switch to a setting of 2 on the top switch equals the value of 20 (2 x 10). Rotating the switch on the bottom switch to a setting of 5 equals the value of 5. The actual address setting is 25 (20 + 5).

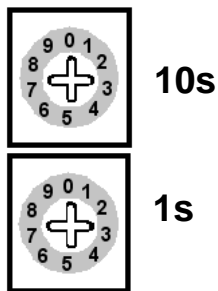

7.1.5 Digital Link Ports (Digital Interfaced MMC-SD Only)

The two 8-pin RJ-45 Digital Link Port connectors (labeled “IN” and “OUT” on the front of the Drive) provide communications between Drives and between a Drive and a Standalone MMC Digital Control. Also provided are two green “Link” lights located between the RJ-45 connectors. The left light will be on if there is a Drive or Digital Control connected to the “IN” port, and the right light will be on if there is a Drive connected to the “OUT” port.

A “straight-through” shielded cable must be used when connecting the Drive to either the Standalone MMC Digital Control or another Drive. Connect the cable from the Drive’s “OUT” port to the next Drive’s “IN” port, or from the Standalone MMC Digital Control’s “B” port to the Drive’s “IN” port. Refer to the Standalone MMC Hardware Manual for Control information.

- Pin descriptions for are provided in [Table 7-8](#)
- Pin assignments are provided in [Table 7-9](#)
- The available Digital Link Port to Digital Drive cables are described in [Table 7-10](#)

Table 7-8: Digital Link Port Pin Description

Digital Link Connector (IN/OUT) Signals		Pin	
Function	Notes	“In” Connector	“Out” Connector
Receive Data +	Receives data from connected drives.	1	3
Receive Data -	Receives data from connected drives.	2	6
Transmit Data +	Transmits data to connected drives.	3	1
Transmit Data -	Transmits data to connected drives.	6	2
Protective Ground	Provides a path for the ground signal to an external single point ground.	Connector Shell	Connector Shell

Table 7-9: Digital Link Port Pin Assignments

Pin	Label	In/Out	Connector Pinout
IN Connector			
1	Receive +	In	<p>RJ-45 Connectors</p>
2	Receive -	In	
3	Transmit +	Out	
4	Not Used	N/A	
5	Not Used	N/A	
6	Transmit -	Out	
7	Not Used	N/A	
8	Not Used	N/A	
Connector Shield	Provides a path for the ground signal to an external single point ground.	In	
OUT Connector			
1	Transmit +	Out	
2	Transmit -	Out	
3	Receive +	In	
4	Not Used	N/A	
5	Not Used	N/A	
6	Receive -	In	
7	Not Used	N/A	
8	Not Used	N/A	
Connector Shield	Provides a path for the ground signal to an external single point ground.	In	

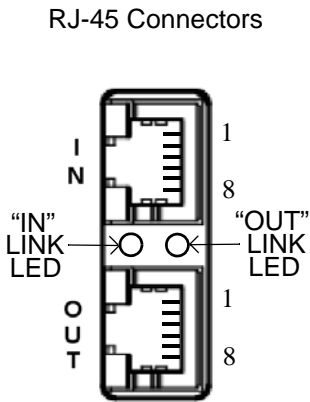
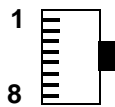
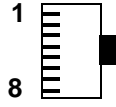

Table 7-10: Digital Link Port “IN” to “OUT” Cables

Part Numbers: .3 M (1.0 ft): M.1302.8285 .6 M (2.0 ft): M.1302.8286 1 M (3.3 ft): M.1302.8287 2 M (6.6 ft): M.1302.8288 3 M (9.8 ft): M.1302.8289 5 M (16.4 ft): M.1302.8300 10 M (32.8 ft): M.1302.8301 15 M (49.2 ft): M.1302.8302 30 M (98.4 ft): M.1302.8303 Cable type: 28 AWG, shielded, twisted pair, 8 conductor.				
8-Pin RJ-45 Plug (to Digital Link Port “OUT”, face view) 		8-Pin RJ-45 Plug (to Digital Drive “IN”, face view) 		
Pin	Signal	Pin	Signal	Notes
1	Transmit Data +	1	Receive Data +	Twisted Pair
2	Transmit Data -	2	Receive Data -	
3	Receive Data +	3	Transmit Data +	Twisted Pair
6	Receive Data -	6	Transmit Data -	
4	None	4	None	Twisted Pair
5	None	5	None	
7	None	7	None	Twisted Pair
8	None	8	None	
Shell	Drain	Shell	Drain	

7.1.6 Feedback Connectors (F1 & F2)

The two 15-pin female Feedback connectors (labeled “F1” and “F2” on the front of the Drive) provide the interface between two feedback devices. A detailed description of the capabilities and limitations of connected devices can be found in [section 7.1.6.1 on page 177](#).

- Pin descriptions for the F1 connector are provided in [Table 7-11](#)
- Pin assignments for the F1 connector are provided in [Table 7-12](#)
- Pin descriptions for the F2 connector are provided in [Table 7-13](#)
- Pin assignments for the F2 connector are provided in [Table 7-14](#)
- The available Flying Lead cable is described in [Table 7-16](#).
- Available Breakout Boxes and Cables are described in [Table 7-17](#).
- Breakout Box dimensions are shown in [Figure 7-2](#)
- Breakout Board dimensions are shown in [Figure 7-3](#)
- Feedback Port to Motor Cables are described in [section 7.1.6.2 on page 182](#)

Table 7-11: Pin Description for Feedback Connector (F1)

Signal Type	Signal Name	Notes	Pin
Incremental Encoder Inputs	A1, A1/, B1, B1/, I1, I1/	Differential A quad B encoder signals.	1, 2, 3, 4, 5, 10
Sinewave Encoder Inputs	Sin, Sin/, Cos, Cos/	Sinewave Encoder signals	1, 2, 3, 4
Sinewave Encoder Data Channel In/Out	RS-485 Data +, RS-485 Data -, RS-485 Clock+, RS-485 Clock-	RS-485 signals for connecting the Sinewave Encoder Data Channel to the drive	5, 10, 12, 13
Motor Commutation Hall Sensor Inputs	Commutation Track S1, S2, S3	Hall device input signals that are used to initialize the commutation angle. They consist of a 74HC14 input with 10 μ s filter and 1 K pull up to +5V. Shared with F2. Not available on Enhanced Feedback drives.	12, 13, 8
Sinewave Encoder Commutation Inputs	Commutation Sin+, Commutation Sin-	Sinewave signals that are used to initialize the motor commutation angle when a Heidenhein Sincoder is used as the motor feedback device.	12, 13
Resolver Inputs	Sin+, Sin-, Cos+, Cos-	Resolver rotor feedback signals used when optional Resolver Interface Board is installed.	1, 2, 3, 4
Resolver Outputs	Carrier+, Carrier-	Resolver rotor excitation signals used when optional Resolver Interface Board is installed.	5, 10
Temperature Input	Temperature	Thermostat (normally- closed) or Thermistor (Phillips KTY84-130 PTC or equivalent recommended) input for detecting over temperature conditions within the motor.	11
+5V Encoder Power Outputs	+5V Source	Regulated +5VDC for powering the attached encoder (F1 pin 14 + F2 pin 14 = 500ma max).	14
+9V Encoder Power Outputs	+9V Source	Regulated +9VDC for powering the attached encoder (F1 pin 7 + F2 pin 7 = 150ma max).	7
Sinewave Encoder Reference Mark Input	Ref Mark, Ref Mark/	Reference Mark input used with some Sinewave Encoders used to indicate motor position within one revolution.	5, 10
Signal and Power Common	Common	Return path for feedback signals and power supplies (+5V and +9V).	6

Table 7-12: Pin Assignments for Feedback Connector (F1)

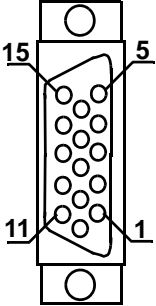
Pin	Feedback Device					In/ Out	Connector Pinout
	Sinewave Encoder						
	Digital Incremental Encoder	Stegmann Hiperface	Endat ^a BISS ^{a,b,c}	Heidenhain Sincoder	Resolver ^d		
1	A1	Cos			Cos+	In	15-pin Female HD D-Sub 
2	A1/	Cos/			Cos-		
3	B1	Sine			Sin+		
4	B1/	Sine/			Sin-		
5	I1	RS-485 Data+		Ref Mark	Carrier+	Note ^e	
6	Common					In/Out	
7	N/U	+9V Source	N/U	N/U	N/U	Out	
8	Commutation Track S3 ^f	N/U	N/U	N/U	N/U	In	
9	N/U			Commuta- tion Cos+	N/U		
10	I1/	RS-485 Data-		Ref Mark/	Carrier-	Note ^e	
11	Temperature					In	
12	Commutation Track S1 ^f	N/U	RS-485 Clock+	Commuta- tion Sin+	N/U	In ^g	
13	Commutation Track S2 ^f	N/U	RS-485 Clock-	Commuta- tion Sin-	N/U		
14	+5V Source	N/U	+5V Source		N/U	Out	
15	N/U			Commuta- tion Cos-	N/U	In	
Shell	Shield					N/A	

- a. Available on Digital Interfaced MMC-SD only
- b. Not on all Part Numbers. See [section 7.3.2 on page 211](#) for details
- c. Cos, Cos/, Sine, Sine/ Not Used for BiSS Encoder
- d. Requires installation of optional resolver board.
- e. Pins 5 and 10 are In/Out for Stegmann Hiperface and Endat; Inputs for Digital Incremental, SSI, BiSS, Heidenhain Sincoder; and Outputs for Resolver
- f. Not available on Enhanced Feedback drives
- g. Pins 12 and 13 are Outputs for ENDAT, SSI, and BiSS

Table 7-13: Pin Description for Feedback Connector (F2) (Digital Interfaced MMC-SD Only)		
Signal Type	Notes	Pins
Incremental Encoder Input	Differential A quad B encoder signals.	1,2, 3, 4, 5, 10
Motor Commutation Hall Sensor Inputs	Hall-device input signals that are used to initialize the motor commutation angle. They consist of a 74HC14 input with a 10 μ s filter and a 1K pull-up to +5V. Shared with F1. Note that Hall Sensors cannot be connected to the F1 connector on enhanced Feedback drives.	8, 12, 13
Temperature Input	Thermostat (normally-closed) or Thermistor (Phillips KTY84-130 PTC or equivalent recommended) input for detecting over temperature conditions within the motor. If a thermostat is used, connect one side to 0V, and the other side to the Temperature Input (pin 11).	11
+5V Encoder Power Outputs	Regulated +5VDC for powering the attached encoder (F1 pin 14 + F2 pin 14 = 500ma max).	14
+9V Encoder Power Outputs	Regulated +9VDC for powering the attached encoder (F1 pin 7 + F2 pin 7 = 150ma max).	7
Signal and Power Common	Return path for feedback signals and power supplies (+5V and 9 V).	6

**Table 7-14: Pin Assignments for Feedback Connector (F2)
(Digital Interfaced MMC-SD Only)**

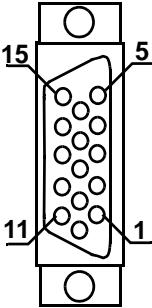
Pin	Label	In/Out	Connector Pinout
1	A2	In	<p>15-pin Female HD D-Sub</p> 
2	A2/	In	
3	B2	In	
4	B2/	In	
5	I2	In	
6	Common	In/Out	
7	+9V	Out	
8	S3	In	
9	Do Not Connect	N/A	
10	I2/	In	
11	Temperature	In	
12	S1	In	
13	S2	In	
14	+5V	Out	
15	Do Not Connect	N/A	
Shell	Shield	In	

7.1.6.1 Feedback Connectors (F1 and F2) Details

The F1 and F2 Feedback connectors support a variety of devices and functions. This section helps clarify the capabilities and limitations of connected devices.

- All signals (other than the encoder inputs) are bussed internally between the two feedback connectors F1 and F2. The bussed signals include motor commutation inputs (except on Enhanced Feedback drives), temperature input, +5V power, +9V power, and encoder power outputs.
- F1 can interface with incremental encoders, sinewave encoders, and resolvers (using the optional resolver interface module). These signals are conditioned and routed to the Drive I/O connector.
- F2 can be designated (in PiCPro) as the motor feedback connector but only if F1 is not (either one or the other must be designated as such).
- F2 can interface with only incremental type encoders.
- Hall Sensors
 - On all but Enhanced Feedback drives: The hall sensor inputs on F1 and F2 are connected together, allowing either F1 or F2 to accept the hall sensor signal, but NOT both. Only one feedback may be connected to motor hall sensor inputs.
 - On Enhanced Feedback drives: Hall sensor can only be connected to F2, allowing a Comcoder to be connected to F2, while simultaneously allowing any supported feedback device to be connected to F1.
- Refer to [Table 7-15](#) for more information regarding the valid combinations of feedback on the F1 and F2 connectors.

Table 7-15: Supported Feedback Combinations	
Drive Feedback Configuration 1 and 4 (in PiCPro Drive Setup)	
F1 (Motor mounted feedback device for motor control)	F2 (Externally mounted feedback device for position feedback)
<ul style="list-style-type: none"> • Incremental Encoder with commutation halls^a • Resolver • Sincoder with commutation halls^a • Endat2.1 (single or multi-turn) • Stegmann Hiperface (single or multi-turn) • BiSS (single or multi-turn) 	<ul style="list-style-type: none"> • Incremental Encoder without commutation halls^b
Drive Feedback Configuration 2 and 3 (in PiCPro Drive Setup)	
F1 (Externally mounted feedback device for position feedback)	F2 (Motor mounted feedback device for motor control)
<ul style="list-style-type: none"> • Sincoder without commutation halls • Resolver 	<ul style="list-style-type: none"> • Incremental Encoder with commutation halls (Comcoder)

- a. On a Enhanced Feedback drive, commutation halls cannot be connected to F1
- b. On a Enhanced Feedback drive, an Incremental Encoder with Halls can be connected to F2 while optionally any supported feedback device is connected to F1

Table 7-16: Feedback Port (F1 and F2) to Flying Lead Cable			
1 M (3.3 ft): M.3000.1053 3 M (9.8 ft): M.3000.1054 6 M (19.7 ft): M.3000.1055 9 M (29.5 ft): M.3000.1056 Cable type: 28 AWG, (1 pair 16 AWG) shielded, twisted pair, 16 conductor.			
15-Pin HD male D-sub (to F1/F2 Port, face view)			
Pin	Signal	Color	Notes
1	A1, Cos, Cos+	Yellow	Twisted
2	A1/, Cos/, Cos-	White/Yellow	Pair
3	B1, Sine, Sin+	Blue	Twisted
4	B1/, Sine/, Sin-	White/Blue	Pair
5	I1, RS-485 Data+, Ref Mark, Carrier+	Black	Twisted
10	I1/, RS-485 Data-, Ref Mark/, Carrier-	White/Black	Pair
8	Commutation Track S3	Red	Twisted
NC	N/A	White/Red	Pair
9	Commutation Cos+	Orange	Twisted
15	Commutation Cos-	White/Orange	Pair
14	+5V source,(16 AWG)	Gray	Twisted
6	Common (16 AWG)	White/Gray	Pair
7	+9V Source	Brown	Twisted
NC	N/A	White/Brown	Pair
11	Temperature	Green	Twisted
NC	N/A	White/Green	Pair
12	Commutation Track S1, RS-485 Clock+, Commutation Sin+	Violet	Twisted
13	Commutation Track S2, RS-485 Clock-, Commutation Sin-	White/Violet	Pair
Shell	Drain	N/A	

Table 7-17: Feedback Ports (F1 and F2) Breakout Box and Cables		
Description	Length	Part Number
MMC-SD F1/F2 Port Breakout Board ^a	N/A	M.1302.6970
MMC-SD F1/F2 Port Breakout Box ^b	N/A	M.1302.6972
MMC-SD F1/F2 Port to Breakout Box Cable	1 M (3.3 ft)	M.1302.6976
	3 M (9.8 ft)	M.1302.6977
	9 M (29.5 ft)	M.1302.6979
	15 M (49.2 ft)	M.1302.6980
MMC-SD F1/F2 Port Breakout Box and Cable Kits. These kits include an M.1302.6972 Breakout Box and an inter-connect cable of the indicated length	1 M (3.3 ft)	M.1302.7005
	3 M (9.8 ft)	M.1302.7006
	9 M (29.5 ft)	M.1302.7007
	15 M (49.2 ft)	M.1302.7008

- a. The Breakout Board (see [Figure 7-3 on page 181](#)) is mounted directly to the F1 and/or F2 connector, and provides screw terminals wire termination.
- b. The Breakout Box (see [Figure 7-2 on page 181](#)) is DIN-rail mounted, and provides screw terminal wire termination. Use one of the cables listed in the table to connect between the F1 and/or F2 connector and the Breakout Box.

Figure 7-2: Feedback Port (F1 and F2) Breakout Box Dimensions

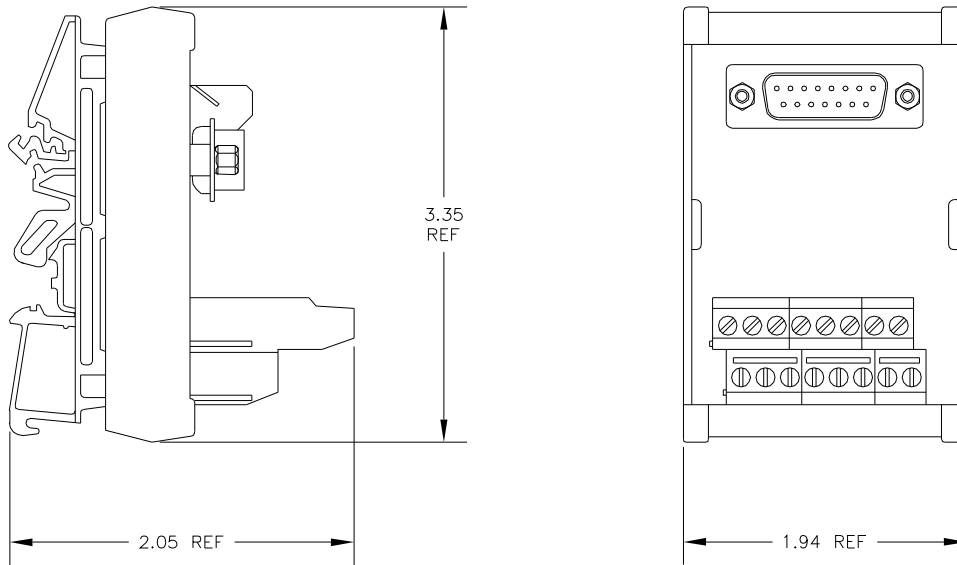

D15 SUB/P
PART NO. M.1302.6972

Figure 7-3: Feedback Port (F1 and F2) Breakout Board Dimensions

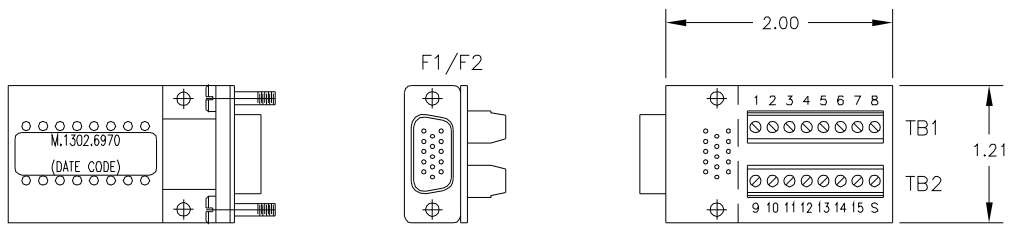

DANAHER MOTION PART NUMBER	DANAHER MOTION SHORT DESCRIPTION
M.1302.6970	BKOUT BD,F1/F2,MMC-SD DR MT

7.1.6.2 Feedback Port (F1/F2) to Motor Cables

Several cables are available that allow easy connection between the Feedback Port (F1/F2) and various Kollmorgen motors. These cables are detailed in [Table 7-18](#) through [Table 7-29](#). For information on Non-Flex versus Hi-Flex cables, refer to [section 10.1 on page 287](#).

Table 7-18: F1/F2 Endat/BiSS to AKM/DDR Motor Cables		
For Connection Diagram, see Table 7-19 on page 183		
Length	Non-Flex P/N	Hi-Flex P/N
1 M (3.3 ft)	M.1302.8605	M.1302.8613
3 M (9.8 ft)	M.1302.8437	M.1302.8438
6 M (19.7 ft)	M.1302.8606	M.1302.8614
9 M (29.5 ft)	M.1302.8607	M.1302.8615
15 M (49.2 ft)	M.1302.8608	M.1302.8616
30 M (98.4 ft)	M.1302.8609	M.1302.8617

Table 7-19: Feedback Port (F1/F2) ENDAT/BiSS to AKM/DDR Motor Cable

For Part Numbers, see Table 7-18 on page 182



Twisted Pair 7 pair 28 AWG 1 pair 16 AWG 1 pair 22 AWG	15-Pin HD male D-sub Connector to MMC Smart Drive		Connector to Motor		
					
Wire Color	Pin Number	Signal Type	Pin Number	Jumper Connections	Signal Type
Yellow	1	COS	9		B+
White/Yellow	2	COS/	1		B-
Blue	3	SIN	11		A+
White/Blue	4	SIN/	3		A-
Black	5	DATA+	5		DATA
White/Black	10	DATA-	13		DATA/
Violet	12	CLOCK+	8		CLOCK
White/Violet	13	CLOCK-	15		CLOCK/
Red	N/U	N/A	12		UnSENSE VCC
White/Red	N/U	N/A	10		UnSENSE COM
Green	11	TEMPERATUR	7		THERMAL
White/Green	N/U	N/A	14		THERMAL
Orange	N/U	N/A	N/U		N/A
White/Orange	N/U	N/A	N/U		N/A
Brown	7	9 VDC	N/U		N/A
White/Brown	N/U	N/A	N/U		N/A
Gray	14	+5 VDC	4		5VDC
White/Gray	6	COM	2	GND	
N/C	9	N/A	6	N/C	
N/C	15	N/A	16	N/C	
N/C	8	N/A	17	N/C	

Table 7-20: F1/F2 Resolver to AKM/DDR Motor Cables		
For Connection Diagram, see Table 7-21 on page 185		
Length	Non-Flex P/N	Hi-Flex P/N
1 M (3.3 ft)	M.1302.8618	M.1302.8630
3 M (9.8 ft)	M.1302.8439	M.1302.8450
6 M (19.7 ft)	M.1302.8619	M.1302.8631
9 M (29.5 ft)	M.1302.8620	M.1302.8632
15 M (49.2 ft)	M.1302.8621	M.1302.8633
30 M (98.4 ft)	M.1302.8622	M.1302.8634

Table 7-21: Feedback Port (F1/F2) Resolver AKM/DDR Motor

For Part Numbers, see [Table 7-20 on page 184](#)

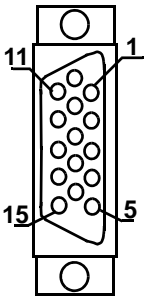
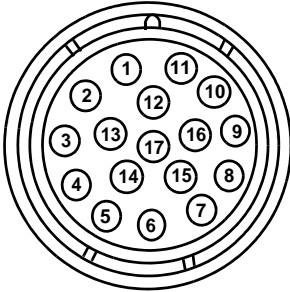
Twisted Pair 4 pair 24 AWG	D-sub 15-Pin HD Male Connector to MMC Smart Drive		Connector to Motor		
					
Wire Color	Pin Number	Signal Type	Pin Number	Jumper Connections	Signal Type
Black	1	COS+	7		COS+
White/Black	2	COS-	3		COS-
Red	3	SIN+	8		SIN+
White/Red	4	SIN-	4		SIN-
Green	5	REF+	9		REF+
White/Green	10	REF-	5		REF-
Orange	11	TEMP+	2		TEMP+
White/Orange	6	COM	6		TEMP-
N/C	7	9 VDC	9		9 VDC
N/C	8	N/A	N/U		N/A
N/C	9	+5 VDC	10	+5 VDC	
N/C	12	COM	1	N/C	
N/C	13	N/A	10	N/C	
N/C	14	N/A	11	N/C	
N/C	15	N/A	12	N/C	

Table 7-22: F1/F2 Encoder to AKM/DDR Motor Cables		
For Connection Diagram, see Table 7-23 on page 187		
Length	Non-Flex P/N	Hi-Flex P/N
1 M (3.3 ft)	M.1302.8590	M.1302.8600
3 M (9.8 ft)	M.1302.8447	M.1302.8435
6 M (19.7 ft)	M.1302.8591	M.1302.8601
9 M (29.5 ft)	M.1302.8542	M.1302.8602
15 M (49.2 ft)	M.1302.8594	M.1302.8603
30 M (98.4 ft)	M.1302.8595	M.1302.8604

Table 7-23: Feedback Port (F1/F2) Encoder to AKM/DDR Motor

For Part Numbers, see [Table 7-22 on page 186](#)

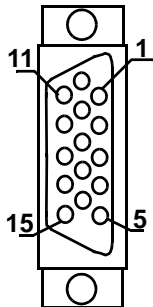
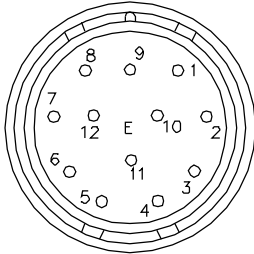

Twisted Pair 8 pair 28 AWG 1 pair 16 AWG		D-sub 15-Pin HD Male Connector to MMC Smart Drive		Connector to Motor	
					
Wire Color	Pin Number	Signal Type	Pin Number	Jumper Connections	Signal Type
Yellow	1	A	3		A
White/Yellow	2	A/	4		A/
Blue	3	B	1		B
White/Blue	4	B/	2		B/
Black	5	I	5		I
White/Black	10	I/	6		I/
Violet	12	S1	15		S1
White/Violet	13	S2	16		S2
Red	8	S3	17		S3
White/Red	N/U	N/A	N/U		N/A
Green	11	TEMPERATURE	8		TEMPERATURE+
White/Green	N/U	N/A	9		TEMPERATURE-
Orange	N/U	N/A	N/U		N/A
White/Orange	N/U	N/A	N/U		N/A
Brown	7	9 VDC	11		N/A
White/Brown	N/U	N/A	N/U	N/A	
Gray	14	+5 VDC	10	+5 VDC	
White/Gray	6	COM	7	COM	
N/C	9	N/A	12	N/C	
N/C	15	N/A	13	N/C	
			14	N/C	

Table 7-24: F1/F2 Encoder to LSM/MSM Motor Cables		
For Connection Diagram, see Table 7-25 on page 189		
Length	Non-Flex P/N	Hi-Flex P/N
1 M (3.3 ft)	M.1302.0944	M.1302.5834
3 M (9.8 ft)	M.1302.0945	M.1302.5835
9 M (29.5 ft)	M.1302.0946	M.1302.5836
15 M (49.2 ft)	M.1302.0947	M.1302.5837
30 M (98.4 ft)	M.1302.0948	M.1302.5838

Table 7-25: Feedback Port (F1/F2) Encoder to LSM or MSM Motors

For Part Numbers, see [Table 7-24 on page 188](#)

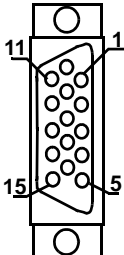
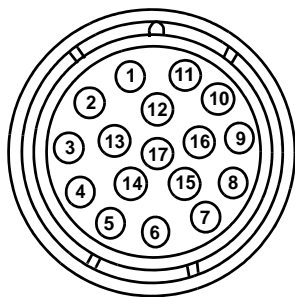

Wire Color	Pin Number	Signal Type	Pin Number	Jumper Connections	Signal Type
<p>Twisted Pair 8 pair 28 AWG 1 pair 16 AWG</p>					
<p>D-sub 15-Pin HD Male Connector to MMC Smart Drive</p> 			<p>Connector to Motor</p> 		
Yellow	1	A	1		A
White/Yellow	2	A/	2		A/
Blue	3	B	3		B
White/Blue	4	B/	4		B/
Black	5	I	5		I
White/Black	10	I/	6		I/
Violet	12	S1	15		S1
White/Violet	13	S2	16		S2
Red	8	S3	17		S3
White/Red	N/U	N/A	N/U		N/A
Green	11	TEMPERATURE	13		TEMPERATURE+
White/Green	N/U	N/A	14		TEMPERATURE-
Orange	N/U	N/A	N/U		N/A
White/Orange	N/U	N/A	N/U		N/A
Brown	7	9 VDC	9		9 VDC
White/Brown	N/U	N/A	N/U		N/A
Gray	14	+5 VDC	10		+5 VDC
White/Gray	6	COM	11		COM
N/C	9	N/A	7		N/C
N/C	15	N/A	8		N/C
			12	N/C	

Table 7-26: F1/F2 Encoder to FSM Motor Cables		
For Connection Diagram, see Table 7-27 on page 191		
Length	Non-Flex P/N	Hi-Flex P/N
1 M (3.3 ft)	M.1301.3927	N/A
3 M (9.8 ft)	M.1301.4011	N/A
9 M (29.5 ft)	M.1301.4012	N/A
15 M (49.2 ft)	M.1301.4013	N/A
30 M (98.4 ft)	M.1301.4014	N/A

Table 7-27: Feedback Port (F1/F2) Encoder to FSM Motors

For Part Numbers, see [Table 7-26 on page 190](#)

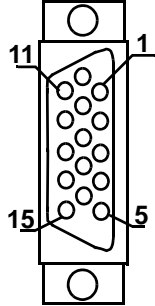
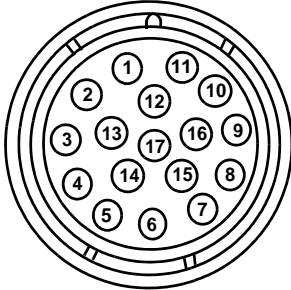
Wire Color	Pin Number	Signal Type	Pin Number	Jumper Connections	Signal Type
D-sub 15-Pin HD Male Connector to MMC Smart Drive 					
Connector to Motor 					
Twisted Pair, 28 AWG, 16 AWG					
Wire Color	Pin Number	Signal Type	Pin Number	Jumper Connections	Signal Type
Black	1	A	A		A
White/Black	2	A/	B		A/
Red	3	B	C		B
White/Red	4	B/	D		B/
Green	5	I	E		I
White/Green	10	I/	F		I/
Gray	14	+5V	J		+5VDC
White/Gray	6	COM	K		+5VDC
			L		COM
			M		COM
Blue	13	S2	S		TEMPERATURE-
			N		S2
			T		S1
Brown	8	S3	P		S3
			11		TEMPERATURE
White/Violet	N/U	N/A	7	N/A	
			9	N/A	
White/Violet	N/U	N/A	15	N/C	
			N/U	N/C	

Table 7-28: F1/F2 Encoder to YSM Motor Cables		
For Connection Diagram, see Table 7-29 on page 193		
Length	Non-Flex P/N	Hi-Flex P/N
1 M (3.3 ft)	M.1301.3983	N/A
2 M (6.6 ft)	M.1302.7675	N/A
3 M (9.8 ft)	M.1301.3984	N/A
9 M (29.5 ft)	M.1301.3985	N/A
15 M (49.2 ft)	M.1301.3986	N/A
30 M (98.4 ft)	M.1301.3987	N/A

Table 7-29: Feedback Port (F1/F2) Encoder to YSM Motors

For Part Numbers, see [Table 7-28 on page 192](#)

Twisted Pair, 28 AWG 16 AWG	D-sub 15-Pin HD Male Connector to MMC Smart Drive		Connector to Motor		
					
Wire Color	Pin Number	Signal Type	Pin Number	Jumper Connections	Signal Type
Black	1	A	9	NO JUMPERED PINS	A
White/Black	2	A/	10		A/
Red	3	B	11		B
White/Red	4	B/	12		B/
Green	5	I	13		I
White/Green	10	I/	14		I/
Gray	14	+5V	22		+5VDC
White/Gray	6	COM	23		COM
Blue	13	S2	17		S2
White/Blue	12	S1	15		S1
Brown	8	S3	19		S3
White/Brown	N/A	N/C	24		N/C
N/A	7	N/C	1		N/C
N/A	9	N/C	2		N/C
N/A	15	N/C	3		N/C
N/A	11	N/C	4-8		N/C
			16	N/C	
			18	N/C	
			20	N/C	
			21	N/C	
			25-28	N/C	

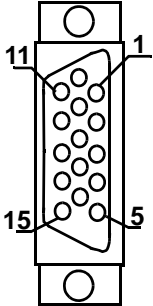
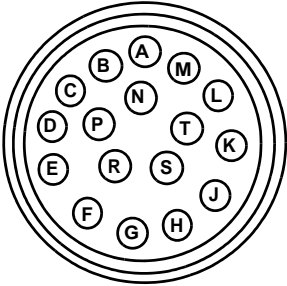
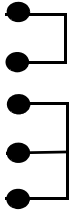
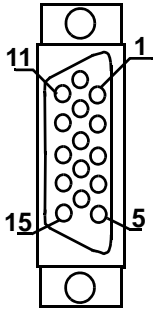
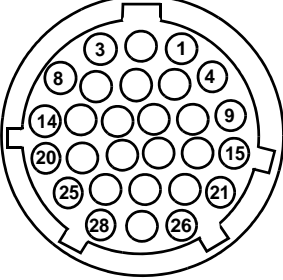
7.1.7 Drive I/O Connector (IO)

The 26-pin HD female D-sub Drive I/O Port connector (labeled "IO" on the front of the Drive) provides connection between various devices and the Drive. This port provides one Analog Input, two differential Fast Inputs, several General Purpose I/O points (wiring example shown in [See Figure 7-6 on page 200](#)), and buffered versions of the feedback device connected to the F1 port.

- Pin descriptions are provided in [Table 7-30](#)
- Pin assignments are provided in [Table 7-31](#)
- Available MMC Control cables are described in [Table 7-32](#)
- The available Flying Lead cable is described in [Table 7-33](#).
- Available Breakout Boxes and Cables are described in [Table 7-34](#).
- Breakout Box dimensions are shown in [Figure 7-4](#)
- Breakout Board dimensions are shown in [Figure 7-5](#)

Signal Type	Notes	Pins
Analog Input	On the Analog Interfaced MMC-SD, this input provides analog velocity or torque commands of 0 to +/- 10V. Separate scale and offset parameters are used relative to the command signal being velocity or torque. On the Digital Interfaced MMC-SD, this input is a general purpose analog input. The digitized voltage presented at this input is available to the Application Program.	14, 15
Fast Inputs (Digital Interfaced MMC-SD only)	Used for latching encoder position.	8, 9, 11, 12
General Purpose Software Assignable Inputs	24VDC sourcing type. Default assignments: Pin 17 (GPIN1) = Drive Enable, Pin 18 (GPIN2) = Fault Reset	17, 18, 19, 20, 21, 22
Buffered F1 Encoder Output	RS485 drivers are used and the signal that is output depends on the encoder or resolver type used. See specifications in Chapter 7 of this manual. These signals are generated after the feedback from the F1 connector is filtered and processed.	1, 2, 3, 4, 5, 6
General Purpose Software Assignable Outputs	24VDC sourcing type. Default assignment: Pin 26 (GPOUT4) = Drive Ready	23, 24, 25, 26
IO24V, IO24COM	24 VDC inputs for powering GPIN and GPOUT I/O.	10, 16

Table 7-31: Pin Assignment for Drive I/O Connector (IO)

Pin	Wiring Label	PiCPro I/O Label	In/Out	Pin	Wiring Label	PiCPro I/O Label	In/Out	Connector Pinout
1	FDBK1B A		Out	14	CMD +		In	26-pin Female HD D-Sub 
2	FDBK1B A/		Out	15	CMD -		In	
3	FDBK1B B		Out	16	IO24COM		In	
4	FDBK1B B/		Out	17	GPIN1	Input1	In	
5	FDBK1B I		Out	18	GPIN2	Input2	In	
6	FDBK1B I/		Out	19	GPIN3	Input3	In	
7	Shield		Out	20	GPIN4	Input4	In	
8	GPIN7 +	Input7	In	21	GPIN5	Input5	In	
9	GPIN7 -		In	22	GPIN6	Input6	In	
10	IO24V		In	23	GPOUT1	Output1	Out	
11	GPIN8 +	Input8	In	24	GPOUT2	Output2	Out	
12	GPIN8 -		In	25	GPOUT3	Output3	Out	
13	Shield			26	GPOUT4	Output4	Out	

Table 7-32: Drive I/O Port to Analog MMC Control "An" Port Cable^a

Part Numbers:

.5 M (1.6 ft): M.1302.5990 1.5 M (4.9 ft): M.1302.5992

1 M (3.3 ft): M.1302.5991 3 M (16.4 ft): M.1302.5993

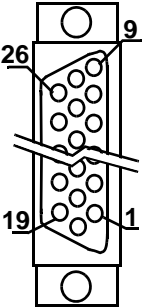
Cable type: 28 AWG (pins 10 & 16 20 AWG), shielded, twisted pair, 26 conductor.

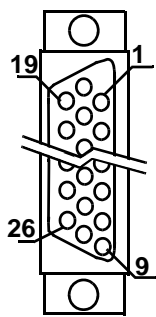
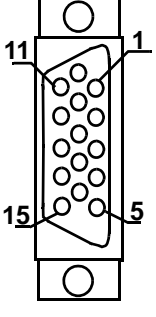
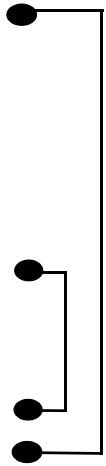
Twisted Pair 9 pair 28 AWG	D-sub 26-Pin HD Male Connector to MMC Smart Drive I/O Port		D-sub 15-Pin HD Male Connector to MMC Controller Axis I/O Port		
					
Wire Color	Pin Number	Signal Type	Pin Number	Jumper Connection	Signal Type
Black	1	A	1		A
White/Black	2	A/	2		A/
Red	3	B	3		B
White/Red	4	B/	4		B/
Green	5	I	5		I
White/Green	6	I/	10		I/
Orange	26	OUT4	6		DCIN+
White/	N/U	N/U	7		DCIN-
Blue	14	CMD+	8		DA+
White/Blue	15	CMD-	9		DA-
Yellow	17	IN1	13		DCOUT1
White/Yellow	18	IN2	14		DCOUT2
Brown	N/U	N/U	N/U		N/A
White/Brown	N/U	N/U	15		DCOSS
Violet	N/U	N/U	N/U		N/A
White/Violet	N/U	N/U	N/U		N/A
Gray	10	IO24V	11	24VDCOUT	
White/Gray	16	IOCOM	12	COM	
N/A	Shell	Shield	Shell		Shield

a. These cables are only used to interface between the Analog MMC-An control and the Analog MMC Smart Drive.

Table 7-33: Drive I/O Port to Flying Lead Cable

Part Numbers:
 1 M (3.3 ft): M.1302.7032 15 M (49.2 ft): M.1302.7036
 3 M (10 ft): M.1302.7034 30 M (98.4 ft): M.1302.7037
 9 M (29.5 ft): M.1302.7035
 Cable type: 28 AWG (pins 10 & 16 20 AWG), shielded, twisted pair, 26 conductor.

26-Pin HD male D-sub (to Drive I/O Port, face view)

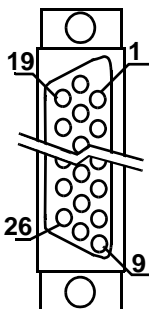

Pin	Signal	Color	Notes	Pin	Signal	Color	Notes
1	A	Black	Twisted	17	GPIN1	Violet	Twisted
2	A/	Blk/Wht	Pair	18	GPIN2	Vio/Wht	Pair
3	B	Red	Twisted	19	GPIN3	Pink	Twisted
4	B/	Red/Wht	Pair	20	GPIN4	Pnk/Wht	Pair
5	I	Green	Twisted	21	GPIN5	Blk/Yel	Twisted
6	I/	Grn/Wht	Pair	22	GPIN6	Gry/Grn	Pair
7	Shield	Black	Twisted	23	GPOUT1	Grn/Red	Twisted
13	Shield	Blue	Pair	24	GPOUT2	Yel/Red	Pair
8	GPIN7 +	Blue	Twisted	25	GPOUT3	Gry/Blu	Twisted
9	GPIN7 -	Blu/Wht	Pair	26	GPOUT4	Yel/Blu	Pair
11	GPIN8 +	Yellow	Twisted	10	IO24V	Gray	Twisted
12	GPIN8 -	Yel/Wht	Pair	16	IO24C	Gry/Wht	Pair
14	CMD +	Brown	Twisted				
15	CMD -	Brn/Wht	Pair				

Table 7-34: Drive I/O Port Breakout Box and Cables		
Description	Length	Part Number
Drive I/O Port Breakout Board ^a	N/A	M.1302.6971
Drive I/O Breakout Box ^b	N/A	M.1302.6973
Drive I/O Port to Breakout Box Cable	1 M (3.3 ft)	M.1302.6982
	3 M (9.8 ft)	M.1302.6984
	9 M (29.5 ft)	M.1302.6985
Drive I/O Port Breakout Box and Cable Kits. These kits include an M.1302.6973 Breakout Box and an interconnect cable of the indicated length.	1 M (3.3 ft)	M.1302.7009
	3 M (9.8 ft)	M.1302.7030
	9 M (29.5 ft)	M.1302.7031

- a. The Drive I/O Breakout Board (see [Figure 7-5 on page 199](#)) is mounted directly to the IO connector, and provides screw terminals wire termination.
- b. The Drive I/O Breakout Box (see [Figure 7-4 on page 199](#)) is DIN-rail mounted, and provides screw terminal wire termination. Use one of the cables listed in the table to connect between the IO connector and the Breakout Box.

Figure 7-4: Drive I/O Port Breakout Box Dimensions

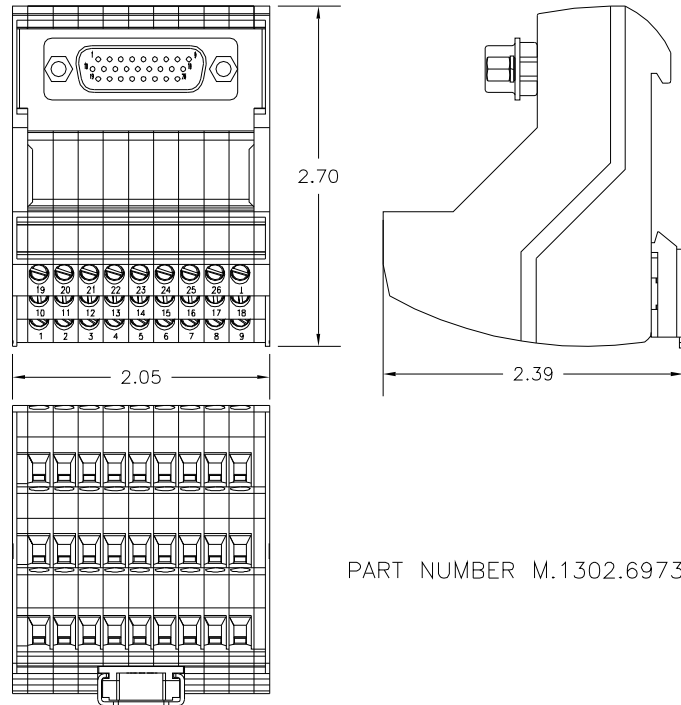

Figure 7-5: Drive I/O Port Breakout Board Dimensions

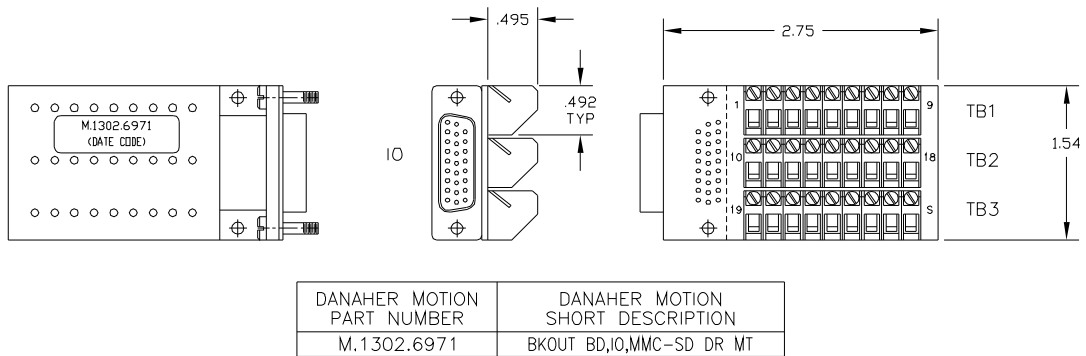
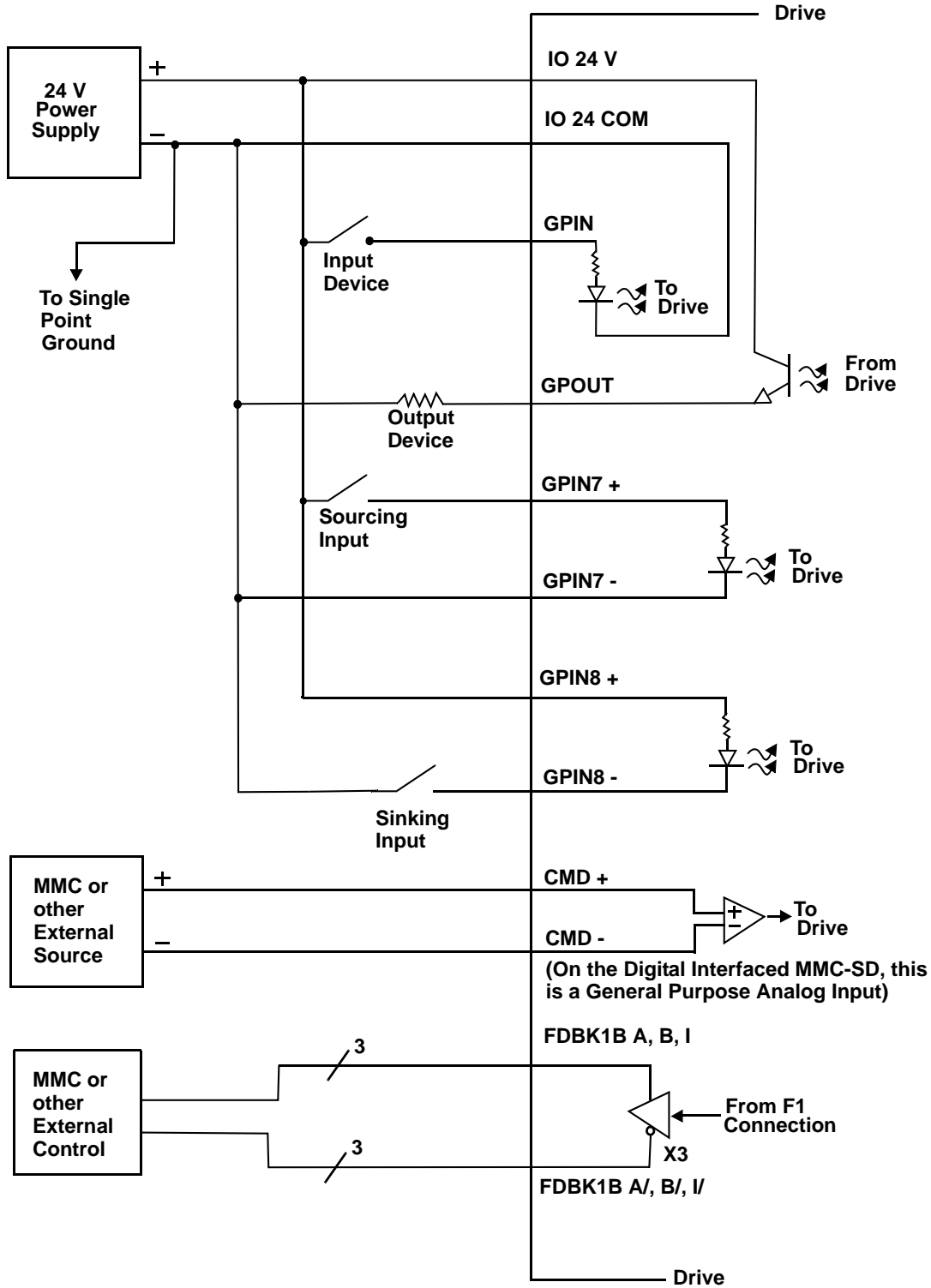

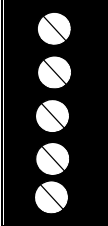

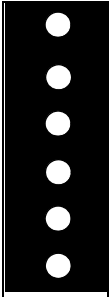

Figure 7-6: Wiring Diagram for Drive I/O Connector (IO)



7.2 Power Section Connectors

This section describes the connectors located on the Power Section (left portion) of the drive.

7.2.1 24 VDC IN/Brake Connector

Table 7-35: Pin Assignment for 24 VDC IN/Brake Connector					
Single Phase Drive					
Terminal Label	Signal Type	Signal Description	PiCPro I/O Label	In/Out	Connector Pinout
+24V	Logic Power	+24V user supplied power signal terminal.	N/A	In	5-pin Pluggable Screw Terminal 
COM	Common	+24V Common	N/A	In	
	Protective Ground	Must be connected to Protective Earth Ground (SPG)	N/A	In	
BR+	Brake Relay +	Refer to Figure Figure 7-7 .	Output5/Relay	Out	
BR-	Brake Relay -			Out	
Three Phase Drive					
Terminal Label	Signal Type	Signal Description	PiCPro I/O Label	In/Out	Connector Pinout
+24V	Logic Power	+24V user supplied power signal terminal.	N/A	In	6-pin Pluggable Cage Clamp Terminal 
COM	Common	+24V Common	N/A	In	
EN	Drive Enable	Safe-off Signal. (See section 7.2.1.1 on page 203).	N/A	In	
	Protective Ground	Must be connected to Protective Earth Ground (SPG)	N/A	In	
BR+	Brake Relay +	Refer to Figure Figure 7-7 .	Output5/Relay	Out	
BR-	Brake Relay -			Out	

NOTE
Use of a diode (as shown) or an external RC type snubber is highly recommended for use with inductive loads, especially DC inductive loads.

Figure 7-7: BR+ and BR- Wiring Examples

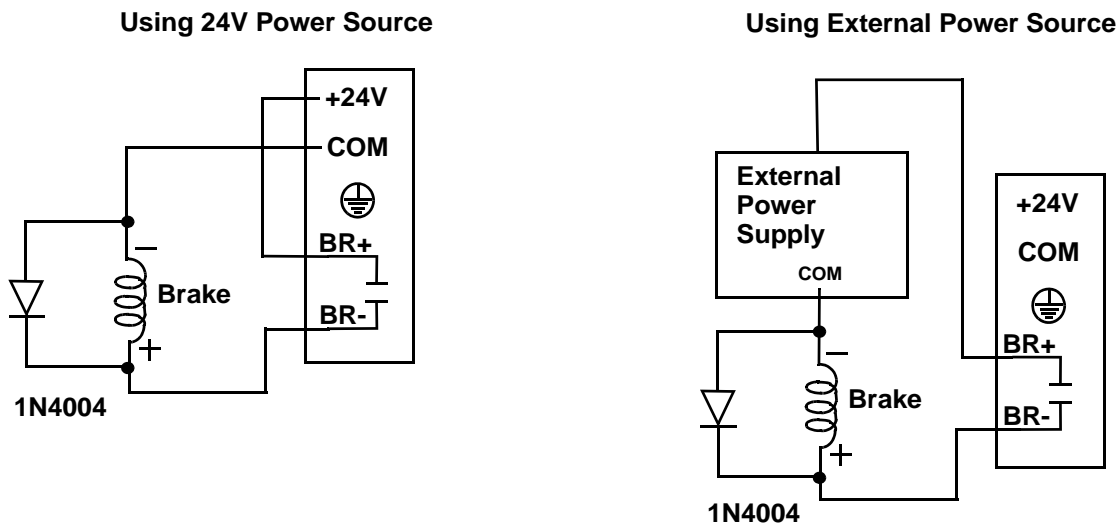

7.2.1.1 "EN" requirements and Safe-off Operation

The 230V Three Phase Drive is available either with Safe-off (-DSO, -DNSO), or without Safe-off (-D, -DN). Regardless, **the "EN" pin located on the 6-pin connector must have 24Vdc applied to it in order for the drive to operate.**

The following two sections describe the behavior of Safe-off Drives and non-Safe-off Drives.

7.2.1.1.1 "EN" Operation on Safe-off Drives

If the Drive includes the Safe-off feature, the Drive will only perform a Safe-off fault if the following two conditions are met:

- The drive is enabled by the application
- The "EN" input pin is not at 24Vdc

The general sequence of operation of a Safe-off Drive is as follows:

1. An external user-supplied circuit provides 24Vdc to the "EN" input
2. The drive is enabled via the Application Program
3. The application controls the motor as desired
4. The drive is disabled via the Application Program
5. The external user-supplied circuit removes 24Vdc from the "EN" input

6. The process is repeated starting with step 1 above as required

If during step 3 above, the user-supplied external circuitry removes 24Vdc from the "EN" input (usually due to a safety violation on the equipment being controlled), the drive will fault, and the motor will coast to a stop. The drive must be powered off and back on to remove the fault condition.

7.2.1.1.2 "EN" operation on non-Safe-off Drives

If the Drive does not include the Safe-off feature, regardless of the sequence of operation, if the "EN" ever loses 24Vdc, the drive faults, and the motor coasts to a stop. The drive must be powered off and back on to remove the fault condition.

7.2.2 Power Connector

The Power Connector consists of a non-pluggable 9-pin screw-terminal block, and provides connection to the incoming AC power and the motor that is being controlled by the Drive.

ADDITIONAL SHUNT RESISTOR INFORMATION

Refer to [section 4.5 on page 58](#) for instructions on choosing, mounting, and connecting Shunt Resistors available from Kollmorgen.

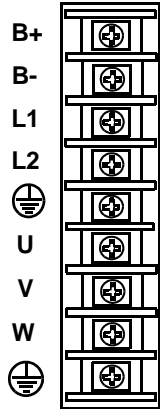

Table 7-36: Pin Assignment for 1 Phase Drive Power Connector				
Single Phase Drive				
Terminal Label	Signal Type	Signal Description	In/Out	Pin Sequence
B+	DC Bus	Power from drive to active shunt	Out	9-pin non-plugable Screw Terminal 
B-				
L1	AC Power	100-240VAC single phase power in to drive.	In	
L2				
	Protective Ground	Must be connected to Protective Earth Ground (SPG).	In	
U	Motor Power	Power U-phase from the drive to the motor.	Out	
V		Power V-phase from the drive to the motor.	Out	
W		Power W-Phase from the drive to the motor.	Out	
	Protective Ground	Connection for motor ground.	In	

Table 7-37: Pin Assignment for 3 Phase Drive Power Connector

Three Phase Drive				
Terminal Label	Signal Type	Signal Description	In/Out	Pin Sequence
NC	DC Bus	Power from drive to active shunt	N/A	9-pin non-plugable Screw Terminal
L1	AC Power	100-240VAC single or three-phase power in to drive.	In	
L2				
L3				
	Protective Ground	Must be connected to Protective Earth Ground (SPG).	In	
U	Motor Power	Power U-phase from the drive to the motor.	Out	
V		Power V-phase from the drive to the motor.	Out	
W		Power W-Phase from the drive to the motor.	Out	
	Protective Ground	Connection for motor ground.	In	

SINGLE PHASE CONNECTION

If single-phase power is used, L1 must be connected to "hot", and L2 must be connected to "neutral". L3 may remain unconnected.

7.2.3 DC Bus/Regen Connector (3-phase drive only)

The DC Bus/Regen Connector consists of a pluggable 4-pin screw-terminal block located on the bottom of the three phase Drive, and provides connection to the drives DC Bus and to an external Regen resistor.

ADDITIONAL SHUNT RESISTOR INFORMATION
Refer to section 4.5 on page 58 for instructions on choosing, mounting, and connecting Shunt Resistors available from Kollmorgen.

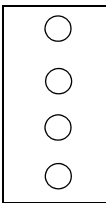
Table 7-38: Pin Assignment Bus/Regen Connector				
Three Phase Drive Only				
Terminal Label	Signal Type	Signal Description	In/Out	Pin Sequence
B+	DC Bus	Power from drive to active shunt	Out	4-pin pluggable Screw Terminal 
B-				
R+	Regen Out	Connection for an external Regen resistor.	Out	
R-				

7.3 Specifications - 230V MMC Smart Drive

7.3.1 General Data for all 230V Models

General Drive Data	
Minimum wire size for input power and motor wires	1.5mm ² (16 AWG) 75° C copper.
Maximum tightening torque for power wire terminals	1.17 Nm (10.4 in-lbs.)
Commutation	Three Phase Sinusoidal
Current Regulator	Digital PI 125 µsec. update rate
Velocity Regulator	Digital PID - 250 µsec. update rate
Environmental Data	
Operating Temperature Range	7° C to 55° C (45° F to 131° F)
Storage Temperature Range	-30° C to 70° C (-22° F to 158° F)
Humidity	5% to 95% non-condensing
Altitude	1500 m (5000 ft) Derate 3% for each 300 m above 1500m
Vibration Limits (per IEC 68-2-6) Operating/Non-operating	10-57 Hz (constant amplitude, 15 mm) 57 - 2000 Hz (acceleration 2 g)
Shock (per IEC 68-2-27) Non-operating	Four shocks per axis (15g/11 msec)
F1 and F2 Feedback Inputs	
Input receiver type	Maxim 3098 A quad B differential RS422 receiver
Encoder signals	Differential quadrature
Input threshold	±200 mV
Input termination	150Ω, provided internally
Maximum input voltage	5V peak to peak differential -10 to +13.2V common mode
Maximum input signal frequency	720 K Hz (2.88 M feedback counts per second)
+5V regulated output	500ma max between F1 and F2
+9V regulated output	150ma max between F1 and F2

General Purpose Inputs	
Configuration	<ul style="list-style-type: none"> • 8 optically isolated 24V DC inputs • Active high • 6 are current sourcing only (current flow into input) • 2 are sink or source
Guaranteed On	15 VDC
Guaranteed Off	5 VDC
Time delay on	1 ms max. (3us for Fast Inputs)
Time delay off	1 ms max (50us for Fast Inputs)
Input voltage	Nominal 24 VDC, maximum 30 VDC
EN (Safe-off) Input	
Configuration	24Vdc (nominal) = Drive Enabled
Guaranteed On	15 VDC
Guaranteed Off	5 VDC
Input Current, Typical	25mA.
General Purpose Outputs	
Configuration	<ul style="list-style-type: none"> • 4 optically isolated 24V DC outputs • Active high • Current sourcing only (current into load) • Short circuit and overload protected
Maximum current	50mA per output
Voltage range	24VDC +15%-10%
Time delay on for resistive loads	50 µsec. max
Time delay off for resistive loads	50 µsec. max
Leakage current in off state	0.5 mA max
Analog Input	
Analog Input	<p>On the Analog Interfaced MMC-SD:</p> <ul style="list-style-type: none"> • Analog velocity or torque, 0 to $\pm 10V$ • 14 bit effective resolution <p>On the Digital MMC-SD:</p> <ul style="list-style-type: none"> • General Purpose Analog Input • 14 bit effective resolution

Digital Link In/Out Ports (Digital Interfaced MMC-SD only)	
"In" port	Sends and receives high speed data to and from connected MMC-SD's "Out" port.
"Out" port	Sends and receives high speed data to and from connected MMC-SD's "In" port.
Cable Type	Shielded, Straight Pinned, CAT5 or better (CAT5e, CAT6, etc.)
Maximum Cable Length	30 m (98.4 ft)

Drive I/O Connector Encoder Emulation Output	
F1 Motor Feedback Type	Input Limit Encoder Emulation Output (A quad B Differential Output)
Incremental Encoder	720 KHz 2.88 M counts/sec. The motor encoder A/B/I inputs are electrically buffered and retransmitted via the Drive I/O connector.
High Resolution Encoder	100 KHz 400 K counts/sec. The encoder SIN/COS signals are electrically squared and retransmitted as A/B. The index mark "I" is synthesized by the drive control DSP. Absolute position information is not available via the Encoder Emulation Output.
Resolver	500 RPS 2.00 M counts/sec. The field-installable resolver interface module converts the motor resolver to 1024 lines/4096 counts per revolution of A/B encoder output. The module synthesizes the index mark "I" once per revolution of the resolver. Absolute position information is not available via the Encoder Emulation Output.
Conformity	
CE Marked (only for Single Phase Drives. Three Phase Drives pending).	Conforms to Low Voltage Directive 73/23/EEC (amended by 93/68/EEC) and EMC Directive 89/336/EEC (amended by 92/31/EEC and 93/68/EEC). Conformance is in accordance with the following standards: EN 50178 and EN61800-3
UL and C/UL Listed	E233454

7.3.2 Physical and Electrical Data for 230V Drives

	Model			
	MMC-SD-0.5-230	MMC-SD-1.0-230	MMC-SD-2.0-230	MMC-SD-3.0-230
Part Numbers^a				
Analog (Standard Width) 1-phase, no BiSS 1(3)-phase, no BiSS Digital (-D, Standard Width) 1-phase, no BiSS 1-phase, BiSS 1(3)-phase, no Safe Off 1(3)-phase, Safe Off 1(3)-ph, no Safe Off, EF ^b 1(3)-ph, Safe Off, EF ^b Digital (-DN, Narrow Width) 1-phase, no BiSS 1-phase, BiSS 1(3)-phase, no Safe Off 1(3)-phase, Safe Off 1(3)-ph, no Safe Off, EF ^b 1(3)-ph, Safe Off, EF ^b	M.1302.5090 M.3000.0929 M.1302.8130 M.3000.0461 M.3000.0911 M.3000.0919 M.3000.1111 M.3000.1115 M.1302.8908 M.3000.0458 M.3000.0915 M.3000.0922 M.3000.1103 M.3000.1107	M.1302.5091 M.3000.0930 M.1302.8131 M.3000.0462 M.3000.0912 M.3000.0920 M.3000.1112 M.3000.1116 M.1302.8910 M.3000.0459 M.3000.0916 M.3000.0923 M.3000.1104 M.3000.1108	M.1302.5092 M.3000.0931 M.1302.8132 M.3000.0463 M.3000.0913 M.3000.0921 M.3000.1113 M.3000.1117 M.1302.8911 M.3000.0460 M.3000.0917 M.3000.0924 M.3000.1105 M.3000.1109	Not Available Not Available Not Available Not Available M.3000.0869 M.3000.0946 M.3000.1114 M.3000.1118 Not Available Not Available M.3000.0868 M.3000.0922 M.3000.1106 M.3000.1110
Weight, lbs (kg)	4.9 (2.23)	5.6 (2.55)	5.7 (2.59)	5.7 (2.59)
AC Input Specifications, 1-phase (3-phase)				
Input Power (kVA)	.5 (.5)	1.0 (1.0)	2.0 (2.0)	2.3 (3.0)
Input Voltage, VAC	100-240 (nominal), 88-265 (absolute limits)			
Input Frequency, Hz	47 - 63			
Nominal Input Current Amps RMS	5 (3)	9 (5)	18 (10)	18 (14)
Maximum Inrush Amps 0-Peak	70 (70)	70 (70)	70 (70)	70 (70)
Power Loss, Watts	22 (22)	37 (37)	70 (70)	90 (90)

AC Output Specifications, 1-phase (3-phase)				
Continuous Output Amps RMS Amps 0-Peak	1.8 (1.8) 2.5 (2.5)	3.5 (3.5) 5.0 (5.0)	7.1 (7.1) 10 (10)	10.6 (10.6) 12.5 (15)
Continuous Output Power 1-phase (3-phase)				
Input = 115 VAC, W	250 (250)	500 (500)	1K (1K)	1.5K (1.5K)
Input = 230 VAC, W	500 (500)	1K (1K)	2K (2K)	2.3K (3K)
Peak Output Current Amps 0-Peak	7.5 (7.5)	15 (15)	30 (30)	30 (30)
Output Frequency, Hz	0-266 (0-266)			
DC Input Power Specifications (24VDC)				
Input Voltage Range	24 VDC +15% -10%			
Typical Input Current	375 mA			
Typical Input Wattage	9 W			
Inrush Current	1.5 A for 10 ms			
Relay Contact for Motor Mechanical Brake				
Rating (resistive load)				
Nominal switching capacity	24 VDC			
Maximum switching power	831 VA			
Maximum switching voltage	250 VAC / 100 VDC			
Maximum switching current	5 A (AC) / 2.5 A (DC)			
Energy Absorbtion Specifications				
DC Bus Capacitance (Internal)	1410 μ F	1880 μ F		
Bus overvoltage threshold	420 VDC			

Joules available for energy absorption		
230V motor w/115V line input	94 joules	126 joules
230V motor w/230V line input	38 joules	51 joules

- a. All Digital 3-phase drives support BiSS encoders
- b. EF indicates that this drive has the Enhanced Feedback feature

7.4 Dimensions for 230V MMC Smart Drive

This section contains dimensional information on the narrow width (-DN) Digital MMC-SD drive, the standard width (-D) Digital MMC-SD drive, and the Analog Interfaced drive (no letter suffix). Use this information to determine mounting hole locations on the drive panel.

When locating the drive on the panel, observe the clearance requirements found in [Table 3-1 on page 21](#). Mount the drive to the panel with #10 bolts and #10 star washers (to ensure proper ground connection).

Figure 7-8: 500 W Narrow Drive (-DN) - Front View

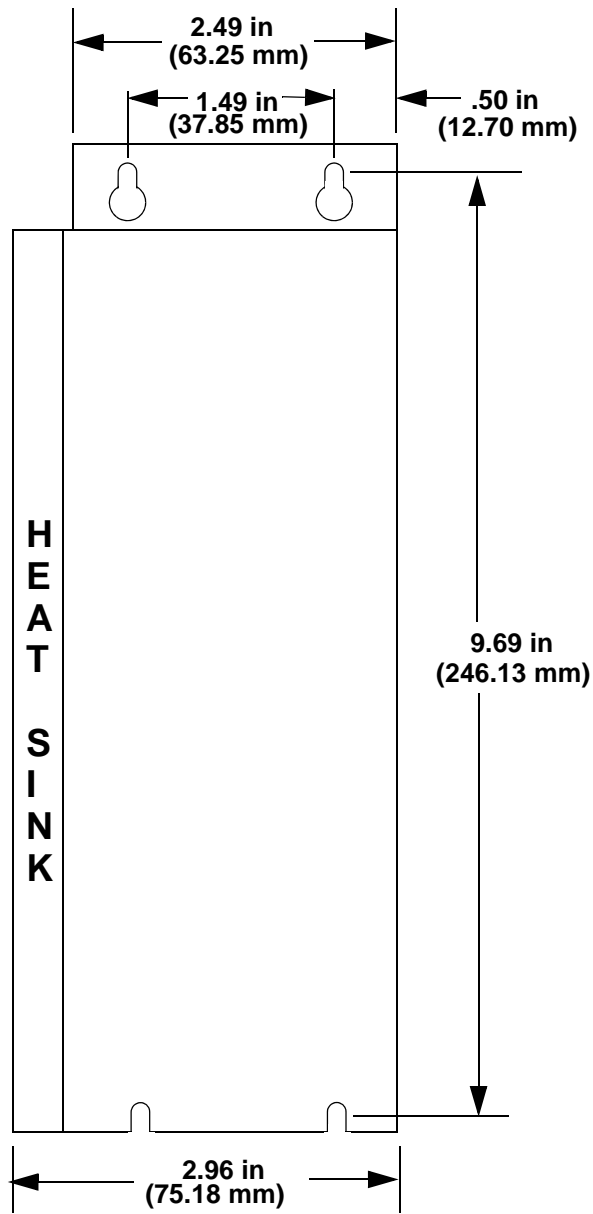

Figure 7-9: 500 W Standard Drive (non-DN) - Front

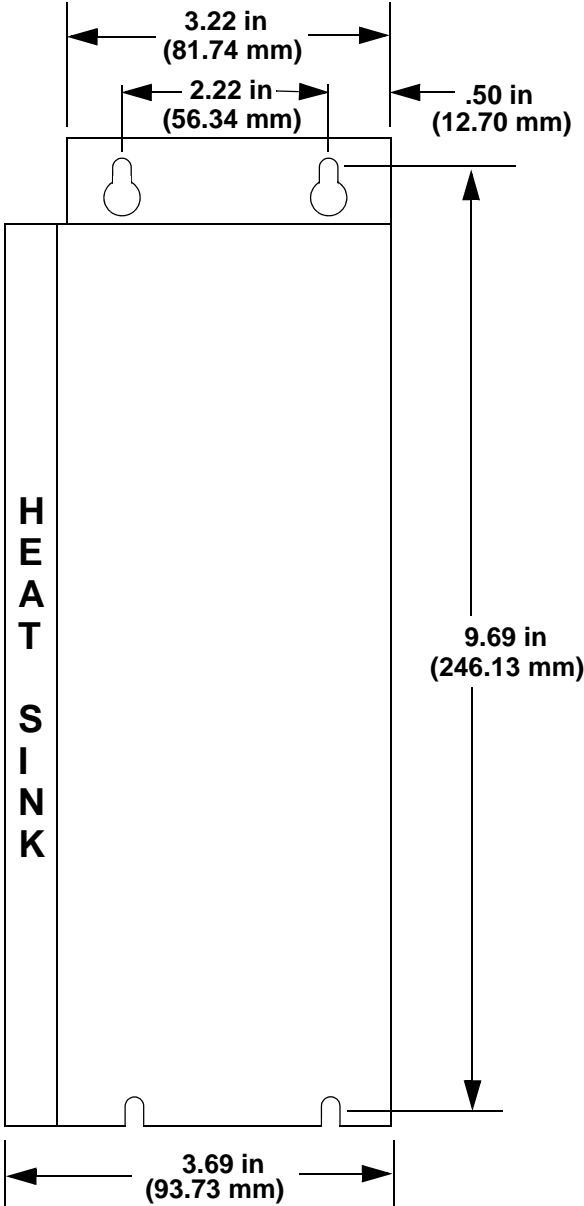

Figure 7-10: 1, 2, and 3 kW Narrow Drive (-DN) - Front View

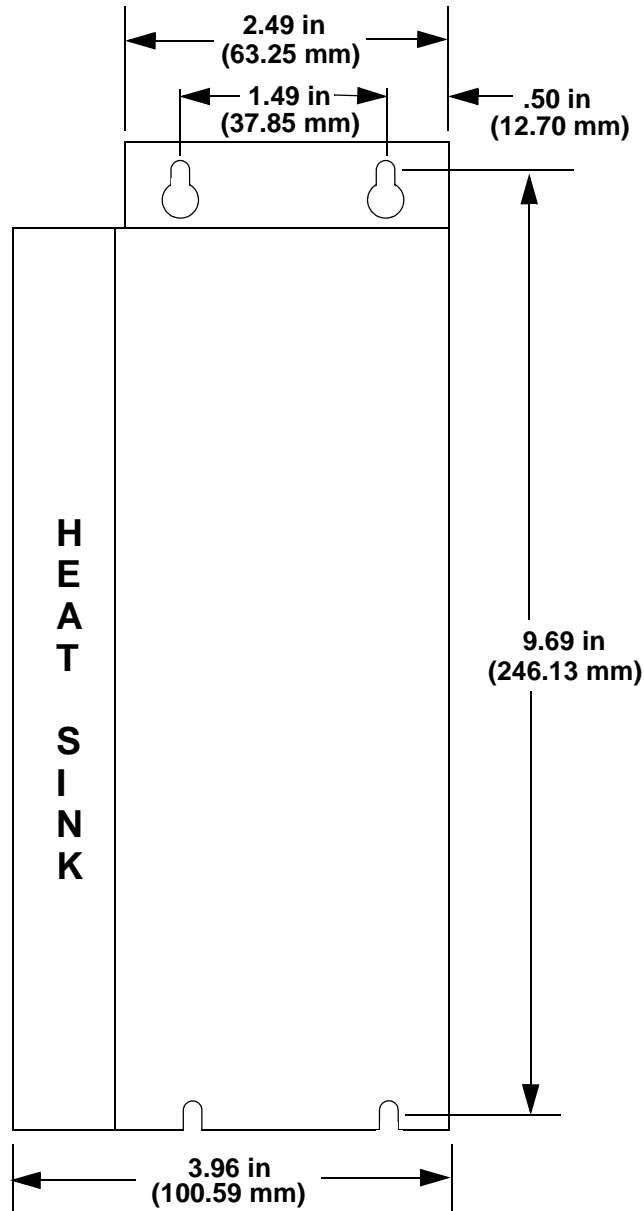

Figure 7-11: 1, 2 and 3 kW Standard Drive (non-DN) - Front View

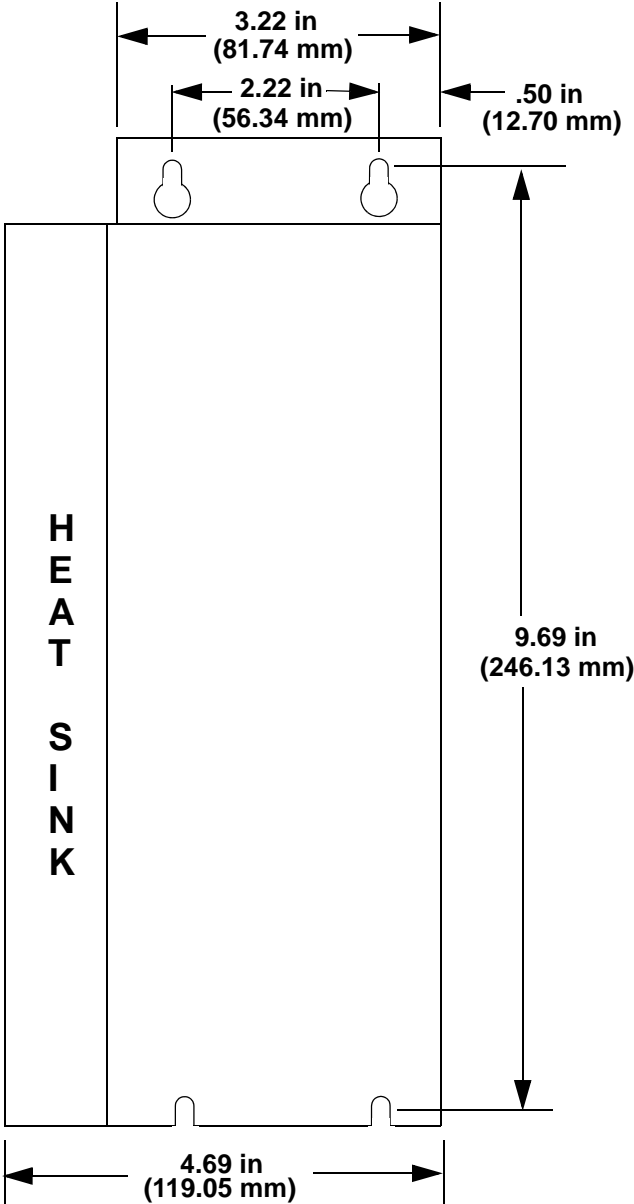
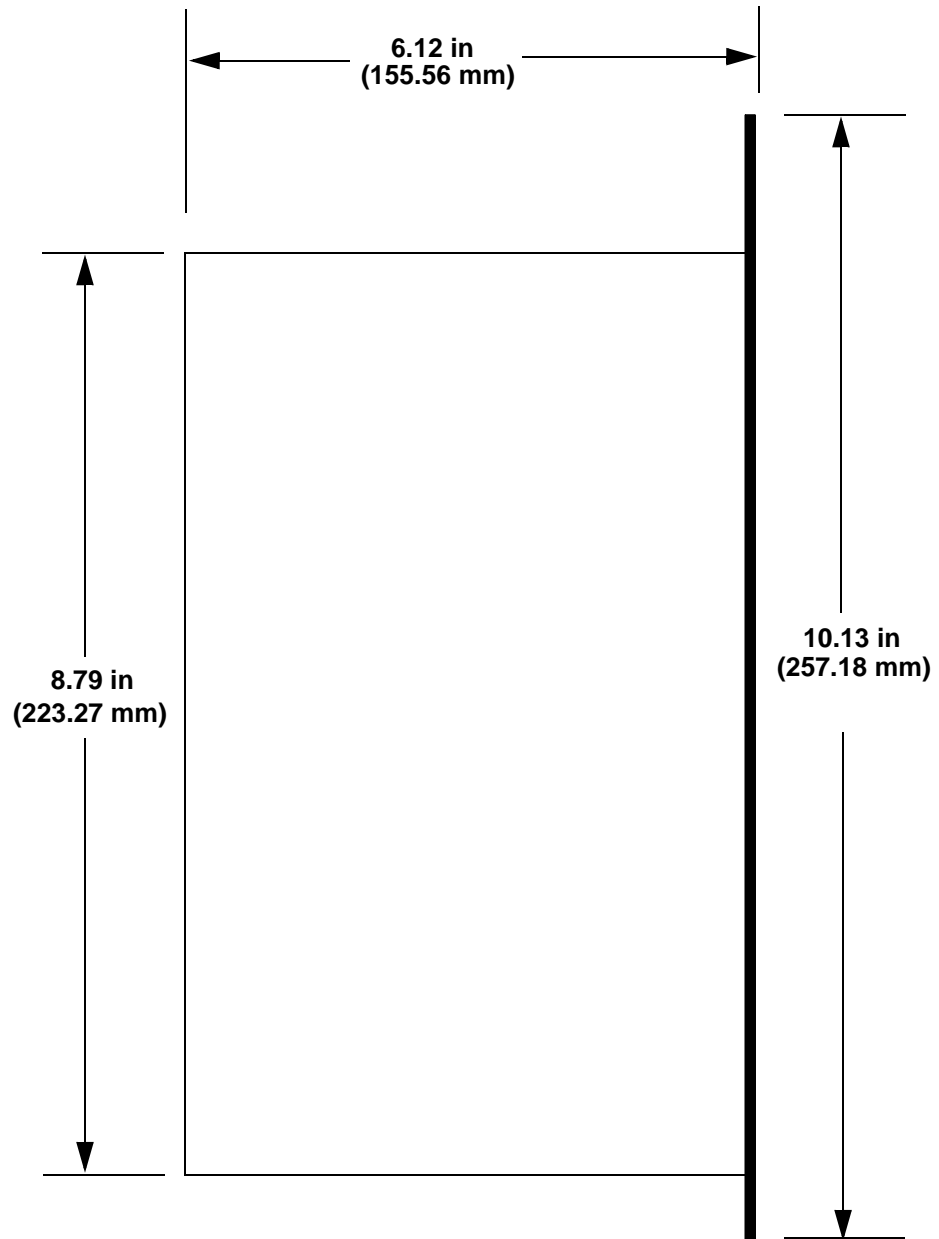

Figure 7-12: 230V Standard (non -DN) and Narrow (-DN) Drive - Side View



8 460V 3-Phase MMC Smart Drive

The 460V MMC Smart Drive is available in both analog and digital interfaced versions, with power ratings from 1.3kW through 65kW. This section describes these drives in detail.

Features include:

- 460V, Three Phase drives available with power ratings of 1.3kW through 65kW
- Drive firmware in user upgradeable Flash memory
- Serial port for communications with PC-resident PICPro
- Internal switch to control a mechanical brake
- Green Power LED and yellow Diagnostic LEDA primary feedback connector (F1), containing the following features:
 - High density female DB-15 connector
 - Supports the following feedback devices:
 - Incremental Encoder (without halls, Enhanced Feedback models only)
 - Comcoder Input (Incremental Encoder with halls, not on Enhanced Feedback models). Note that halls can be connected to F1 or F2, but not both.
 - Stegmann Hiperface encoder
 - High Resolution Resolver
 - 1V p-p Sinewave Encoder
 - Endat 2.1 (2.2 in future release)
 - BiSS (Mode B)
- A secondary feedback connector (F2), containing the following features:
 - High density female DB-15 connector
 - This connector can support one of the following functions:
 - Emulated F1 encoder output
 - Comcoder Input (Incremental Encoder with halls). Note that on non-Enhanced Feedback models, halls can be connected to F1 or F2, but not both.
- Eight General Purpose 24VDC Inputs
- Four General Purpose 24VDC outputs
- $\pm 10V$ command input (Analog Interfaced MMC-SD only)
- Digital Link digital connections (Digital MMC-SD only)
- Optional MMC-SD Control (for Digital MMC-SD only)
- UL Listed and CE Marked.

8.1 Control Section Connectors, Switches, LEDs

The Control Section is located on the right side of the drive, and is identical to the Control Section on the 230V Smart Drive. Refer to [section 7.1 on page 164](#) for

Information on the connectors, switches, and LEDs located on the Control Section of the drive.

8.2 Power Section Connectors

The 460V Smart Drive is available in four frame sizes (size 1 through 4). The Power Section connectors location and function are different among the four frame sizes. Each frame size is described in detail in the following sections.

8.2.1 Size 1 Power Section Connectors

This section describes in detail the connectors located on the Power Section of the Size 1 drives.

The functionality and descriptions for the switches and connectors on the Control Section of the 460V MMC Smart Drives are the same as those on the 230V MMC Smart Drive. Refer to [section 7.1 on page 164](#) for more information.

Figure 8-1: Connectors on the Size 1 460V Smart Drive

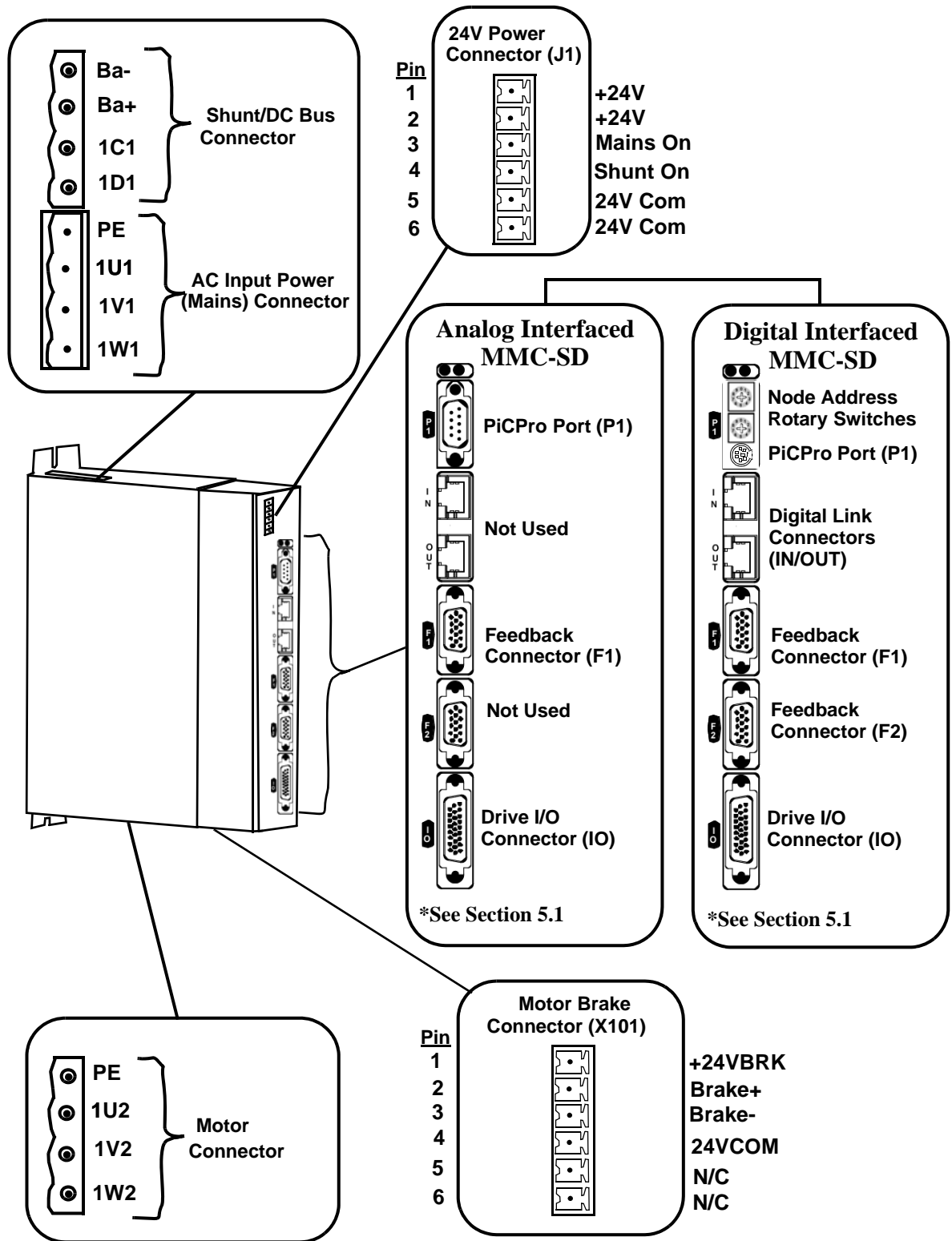

8.2.1.1 Shunt/DC Bus Connector

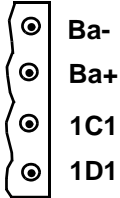
Table 8-1: 460V Size 1 Shunt/DC Bus Connector				
Signal Type	Signal Description	Connector Label	In/Out	Connector
Power	External Shunt Resistor. Used to dissipate energy returned to the drive by the motor.	Ba-	Out	
		Ba+		
DC Bus Power	Direct DC bus connection	1C1 (ZK+)	N/A	
		1D1 (ZK-)		

Note: A 4-pin screw-terminal mating connector is included with the drive. Additional connectors (P/N M.1302.7159) are available from Kollmorgen.

NOTE

The shunt resistor (if installed) across Ba+ and Ba- will be connected across the DC bus when the DC bus reaches the “shunt switch threshold” as shown in the specification table; or when the “Shunt On” input on the J1 connector is active.

NOTE

If a 460V drive is connected to 220V to run a 220V motor, enable the “220V Shunt on 440V Drive” feature using PiCPro, connect GPOUT3 on the Drive I/O (IO) connector to the “Shunt On” input on the J1 connector, and install the appropriate shunt resistor across the Ba+ and Ba- terminals. The shunt resistor will be applied across the DC bus when the DC bus voltage rises above 415 volts, and will be removed when the DC bus voltage falls below 400 volts.

8.2.1.2 AC Power Connector

Table 8-2: 460V Size 1 AC Power Connector

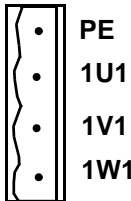
Signal Type	Signal Description	Connector Label	In/Out	Connector
Protective Ground	Protective Earth Ground	PE	Out	
Power	3 phase input power AC source must be center grounded Y system. ^a	1U1	In	
		1V1		
		1W1		

Note: A 4-pin screw-terminal mating connector is included with the drive. Additional connectors (P/N M.1302.7158) are available from Kollmorgen.

a. See important note regarding Input Power Phasing below

NOTE

When wiring Input Power to the drive, proper phasing is required. Specifically, it is necessary that U leads V, and V leads W. Typically, L1, L2, and L3 as found in a standard electrical fuse/disconnect box are properly phased left-to-right. Connect L1 to U, L2 to V, and L3 to W. If, when the drive is powered up and enabled, the drive indicates an Error 35 (Drive Power Module Fault, as indicated on the Drive Status Light and in PiCPro), remove power from the drive, and swap the U and V connections.

8.2.1.3 Motor Connector

Table 8-3: 460V Size 1 Motor Connector

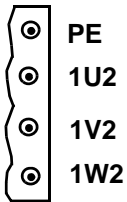
Signal Type	Signal Description	Connector Label	In/Out	Connector
Protective Ground	Protective Earth Ground	PE	Out	
Power	Drive output power to motor.	1U2	Out	
		1V2		
		1W2		

Note: A 4-pin screw-terminal mating connector is included with the drive. Additional connectors (P/N M.1302.7159) are available from Kollmorgen.

8.2.1.4 24V Power Connector (J1)

Table 8-4: 460V Size 1 24V Power Connector (J1)

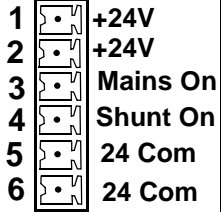
Signal Type	Signal Description	Pin	Connector Label	In/Out	Connector
Power	24 VDC input power	1	+24V	In	Top 
		2	+24V		
24V Logic Input/Output	See footnote ^a	3	Mains On	In/Out	
24V Logic Input/Output	See footnote ^b	4	Shunt On	In/Out	
Power	24 VDC input common to the drive.	5	24V Com	In	
		6	24V Com		

Note: A 6-pin cage-clamp mating connector is included with the drive. Additional connectors (P/N M.1302.7099) are available from Kollmorgen.

- a. As an Output, indicates that the AC Input Power to the drive is OK. As an Input, instructs the drive to run even though AC Input Power is not present. This is typically used when two drives share bus power that is provided by the drive connected to AC Input Power. See [section A.1 on page 353](#) for more information.
- b. As an Output, indicates that the drive's Shunt Output is active. As an Input, instructs the drive to activate its Shunt Output. Whenever the Shunt On signal is active (24Vdc nominal), the user-supplied shunt resistor (installed between Ba+ and Ba-) is connected across the DC bus. See [section A.1 on page 353](#) for more information.

CAUTION
<p>A possible ignition hazard within the MMC 460V Smart Drives exists if excessive current is drawn from the 24 VDC powering the MMC Smart Drive. To prevent this possibility (due to improper wiring or 24 VDC supply failure), a fuse should be used in series with the 24 VDC to the MMC Smart Drive (4 A max). In addition, the 24 VDC shall be supplied by an isolating source such that the maximum open circuit voltage available to the MMC Smart Drive is not more than 30 VDC.</p>

8.2.1.5 Motor Brake Connector (X101)

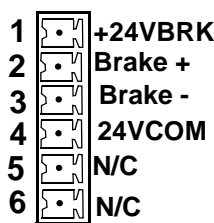
Table 8-5: 460V Size 1 Motor Brake Connector (X101)					
Signal Type	Signal Description	Pin	Connector Label	In/Out	Connector
Power	24 VDC brake input power	1	+24VBRK	In	Top 
Brake control	Brake connections	2	Brake +	Out	
		3	Brake -	In	
Power	24 VDC common	4	24VCOM	Out	
Not Used.		5	N/C	Not Used	
		6			

Note: A 6-pin cage-clamp mating connector is included with the drive. Additional connectors (P/N M.1302.7099) are available from Kollmorgen.

Figure 8-2: Wiring Example for X101 Connector

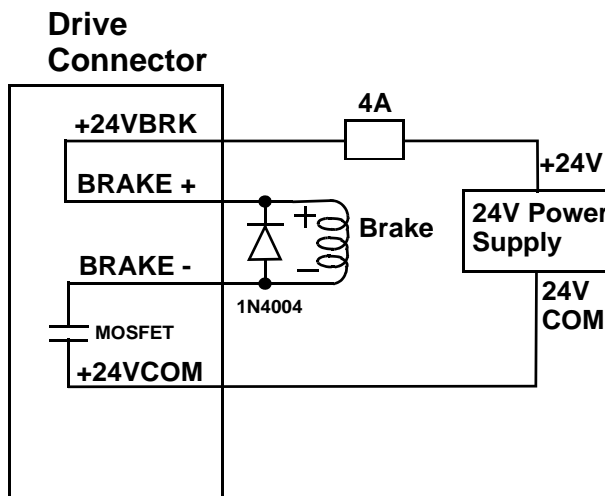

8.2.2 Size 2 Power Section Connectors

This section describes in detail the connectors located on the Power Section of the Size 2 drives.

The functionality and descriptions for the switches and connectors on the Control Section of the 460V MMC Smart Drives are the same as those on the 230V MMC Smart Drive. Refer to [section 7.1 on page 164](#) for more information.

Figure 8-3: Connectors on the Size 2 460V Drive

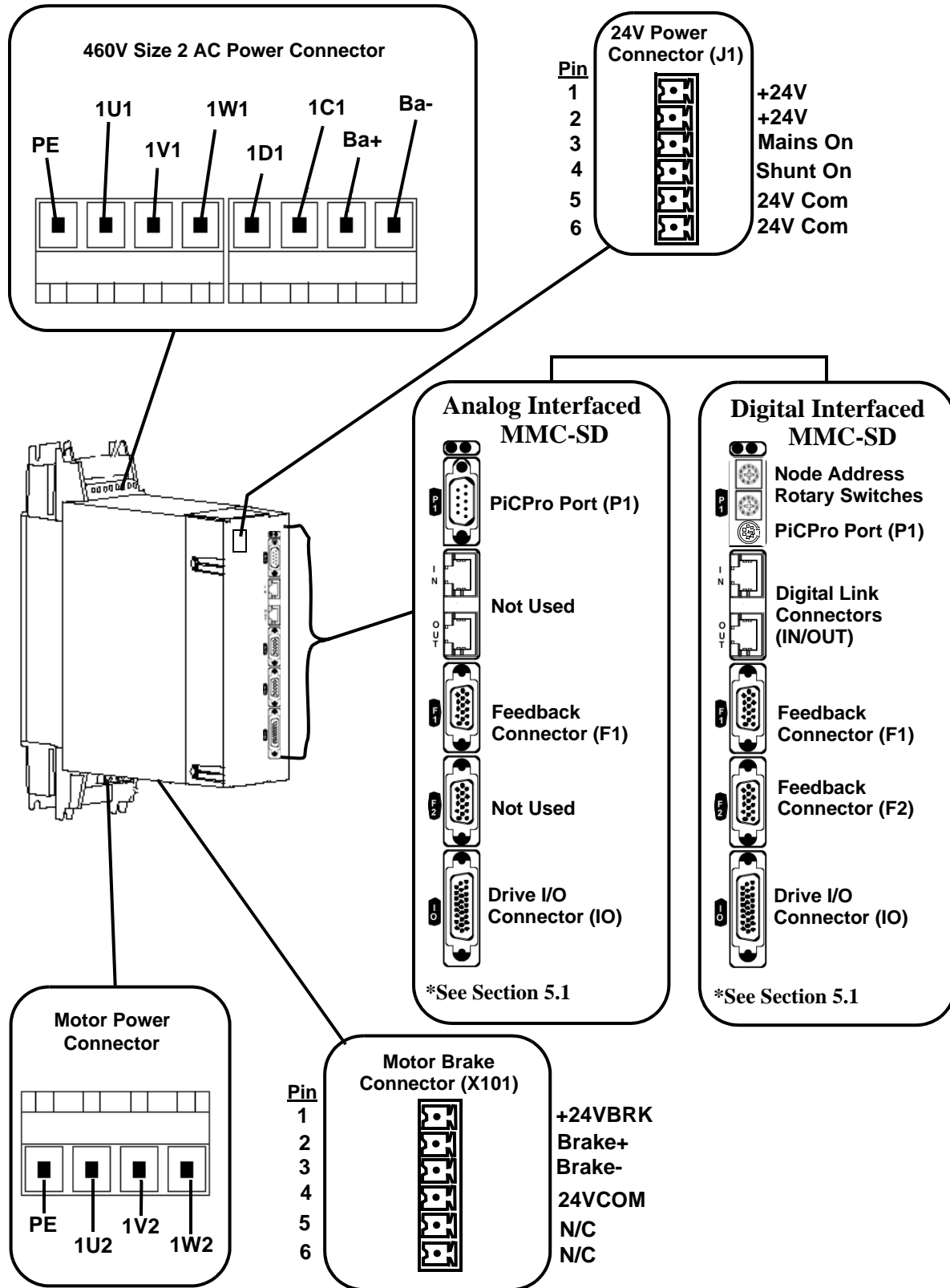

8.2.2.1 AC Power Connector

Table 8-6: 460V Size 2 AC Power Connector			
Signal Type	Signal Description	Connector Label	In/Out
Ground	Protective Ground (Earth)	PE	Out
Power	Three phase AC input power in to drive ^a	1U1	In
		1V1	
		1W1	
DC Bus Power	Direct DC bus connection	1D1 (ZK-)	Out
		1C1 (ZK+)	
Power	External Shunt Resistor used to dissipate energy returned to the drive from motor	Ba+	Out
		Ba-	

a. See important note regarding Input Power Phasing below

NOTE
<p>When wiring Input Power to the drive, proper phasing is required. Specifically, it is necessary that U leads V, and V leads W. Typically, L1, L2, and L3 as found in a standard electrical fuse/disconnect box are properly phased left-to-right. Connect L1 to U, L2 to V, and L3 to W. If, when the drive is powered up and enabled, the drive indicates an Error 35 (Drive Power Module Fault, as indicated on the Drive Status Light and in PiCPro), remove power from the drive, and swap the U and V connections.</p>

NOTE

The shunt resistor (if installed) across Ba+ and Ba- will be connected across the DC bus when the DC bus reaches the “shunt switch threshold” as shown in the specification table; or when the “Shunt On” input on the J1 connector is active.

NOTE

If a 460V drive is connected to 220V to run a 220V motor, enable the “220V Shunt on 440V Drive” feature using PiCPro, connect GPOUT3 on the Drive I/O (IO) connector to the “Shunt On” input on the J1 connector, and install the appropriate shunt resistor across the Ba+ and Ba- terminals. The shunt resistor will be applied across the DC bus when the DC bus voltage rises above 415 volts, and will be removed when the DC bus voltage falls below 400 volts.

8.2.2.2 Motor Connector

Table 8-7: 460V Size 2 Motor Connector

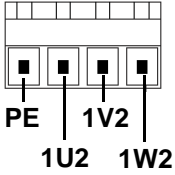
Signal Type	Signal Description	Connector Label	In/Out	Connector
Ground	Protective Ground (Earth)	PE	Out	
Motor	Power U-phase from the drive to the motor	1U2	Out	
	Power V-phase from the drive to the motor	1V2	Out	
	Power W-phase from the drive to the motor	1W2	Out	

8.2.2.3 24V Power Connector (J1)

Table 8-8: 460V Size 2 24V Power Connector (J1)

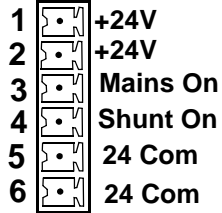
Signal Type	Signal Description	Pin	Connector Label	In/Out	Connector
Power	24 VDC input power	1	+24V	In	Top 
		2	+24V		
24V Logic Input/Output	See footnote ^a	3	Mains On	In/Out	
24V Logic Input/Output	See footnote ^b	4	Shunt On	In/Out	
Power	24 VDC input common to the drive.	5	24V Com	In	
		6	24V Com		

Note: A 6-pin cage-clamp mating connector is included with the drive. Additional connectors (P/N M.1302.7099) are available from Kollmorgen.

- a. As an Output, indicates that the AC Input Power to the drive is OK. As an Input, instructs the drive to run even though AC Input Power is not present. This is typically used when two drives share bus power that is provided by the drive connected to AC Input Power. See [section A.1 on page 353](#) for more information.
- b. As an Output, indicates that the drive’s Shunt Output is active. As an Input, instructs the drive to activate its Shunt Output. Whenever the Shunt On signal is active (24Vdc nominal), the user-supplied shunt resistor (installed between Ba+ and Ba-) is connected across the DC bus. See [section A.1 on page 353](#) for more information.

CAUTION
<p>A possible ignition hazard within the MMC 460V Smart Drives exists if excessive current is drawn from the 24 VDC powering the MMC Smart Drive. To prevent this possibility (due to improper wiring or 24 VDC supply failure), a fuse should be used in series with the 24 VDC to the MMC Smart Drive. Specifically, a 4 A max. “UL248 Series” fuse should be used. In addition, the 24 VDC shall be supplied by an isolating source such that the maximum open circuit voltage available to the MMC Smart Drive is not more than 30 VDC.</p>

8.2.2.4 Motor Brake Connector (X101)

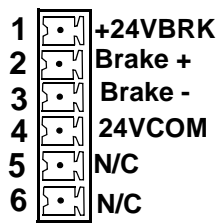
Table 8-9: 460V Size 2 Motor Brake Connector (X101)					
Signal Type	Signal Description	Pin	Connector Label	In/Out	Connector
Power	24 VDC brake input power	1	+24VBRK	In	<div style="text-align: center;"> Top  </div>
Brake control	Brake connections	2	Brake +	Out	
		3	Brake -	In	
Power	24 VDC common (supply and magnet)	4	24VCOM	Out	
Not Used.		5	N/C	Not Used	
		6			

Note: A 6-pin cage-clamp mating connector is included with the drive. Additional connectors (P/N M.1302.7099) are available from Kollmorgen.

Figure 8-4: Wiring Example for X101 Connector

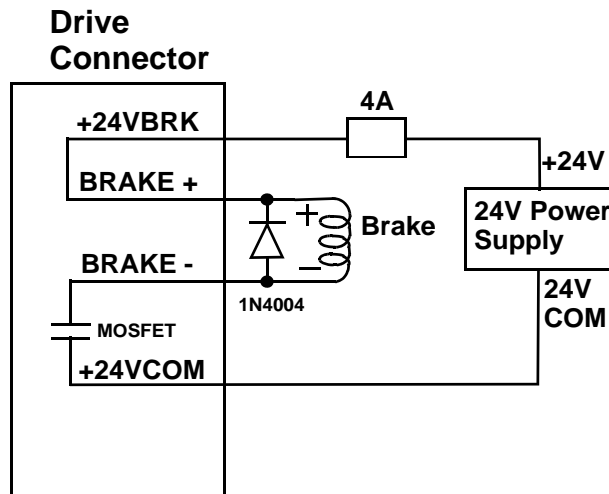

8.2.3 Size 3 Power Section Connectors

This section describes in detail the connectors located on the Power Section of the Size 3 drives.

The functionality and descriptions for the switches and connectors on the Control Section of the 460V MMC Smart Drives are the same as those on the 230V MMC Smart Drive. Refer to [section 7.1 on page 164](#) for more information.

Figure 8-5: Connectors on the Size 3 460V Drive

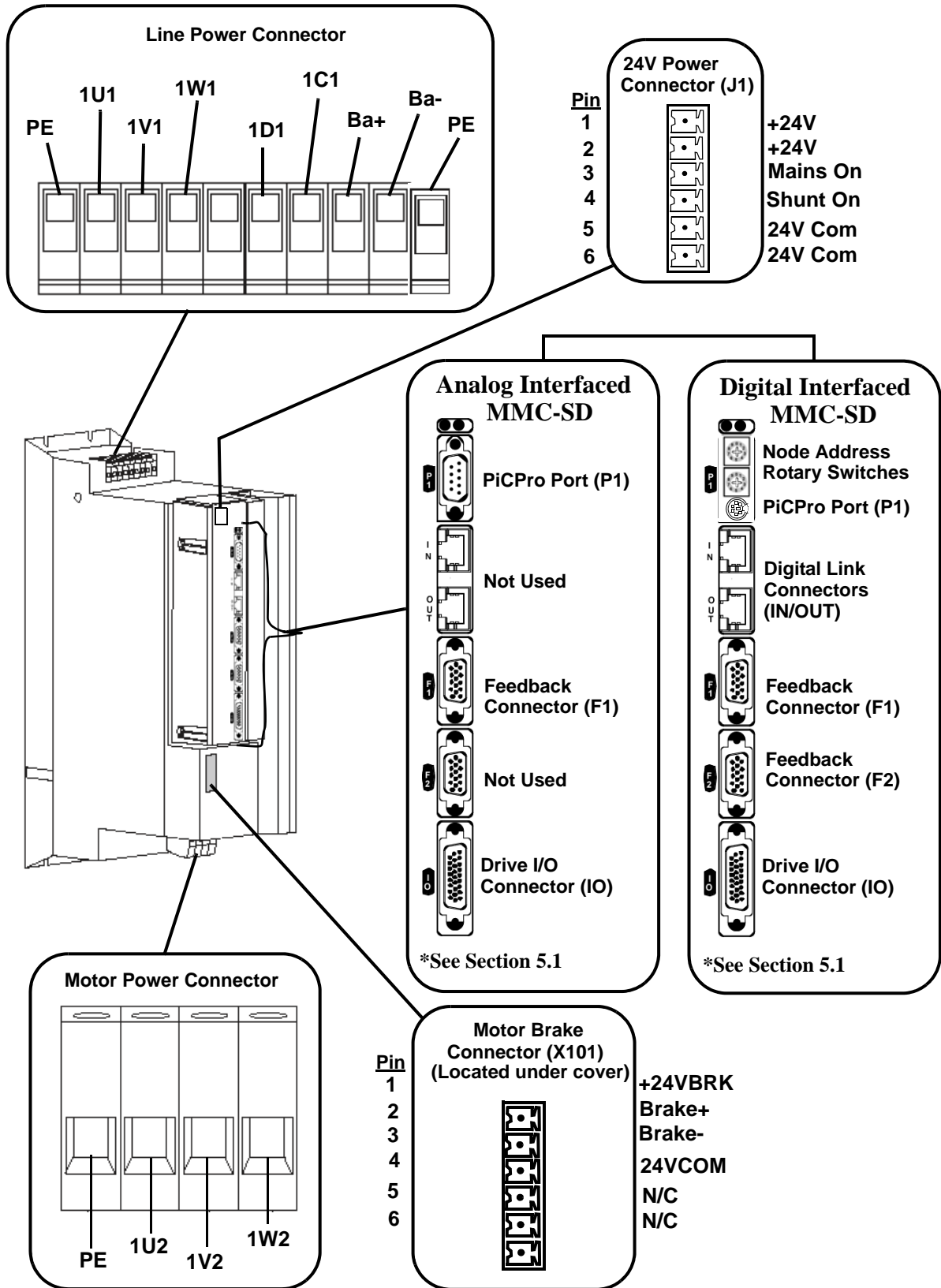

8.2.3.1 AC Power Connector

Table 8-10: 460V Size 3 AC Power Connector			
Signal Type	Signal Description	Connector Label	In/Out
Ground	Protective Ground (Earth)	PE	Out
Power	Three phase AC input power in to drive ^a	1U1	In
		1V1	
		1W1	
DC Bus Power	Direct DC bus connection	1D1 (ZK-)	Out
		1C1 (ZK+)	
	External Shunt Resistor used to dissipate energy returned to the drive from motor	Ba+	Out
		Ba-	

a. See important note regarding Input Power Phasing below

NOTE
<p>When wiring Input Power to the drive, proper phasing is required. Specifically, it is necessary that U leads V, and V leads W. Typically, L1, L2, and L3 as found in a standard electrical fuse/disconnect box are properly phased left-to-right. Connect L1 to U, L2 to V, and L3 to W. If, when the drive is powered up and enabled, the drive indicates an Error 35 (Drive Power Module Fault, as indicated on the Drive Status Light and in PiCPro), remove power from the drive, and swap the U and V connections.</p>

NOTE

The shunt resistor (if installed) across Ba+ and Ba- will be connected across the DC bus when the DC bus reaches the “shunt switch threshold” as shown in the specification table; or when the “Shunt On” input on the J1 connector is active.

NOTE

If a 460V drive is connected to 220V to run a 220V motor, enable the “220V Shunt on 440V Drive” feature using PiCPro, connect GPOUT3 on the Drive I/O (IO) connector to the “Shunt On” input on the J1 connector, and install the appropriate shunt resistor across the Ba+ and Ba- terminals. The shunt resistor will be applied across the DC bus when the DC bus voltage rises above 415 volts, and will be removed when the DC bus voltage falls below 400 volts.

8.2.3.2 Motor Connector

Table 8-11: 460V Size 3 Motor Connector

Signal Type	Signal Description	Connector Label	In/Out	Connector
Ground	Protective Ground (Earth)	PE	Out	
Motor	Power U-phase from the drive to the motor	1U2	Out	
	Power V-phase from the drive to the motor	1V2	Out	
	Power W-phase from the drive to the motor	1W2	Out	

8.2.3.3 24V Power Connector (J1)

Table 8-12: 460V Size 3 24V Power Connector (J1)

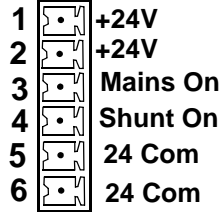
Signal Type	Signal Description	Pin	Connector Label	In/Out	Connector
Power	24 VDC input power	1	+24V	In	Top 
		2	+24V		
24V Logic Input/Output	See footnote ^a	3	Mains On	In/Out	
24V Logic Input/Output	See footnote ^b	4	Shunt On	In/Out	
Power	24 VDC input common to the drive.	5	24V Com	In	
		6	24V Com		

Note: A 6-pin cage-clamp mating connector is included with the drive. Additional connectors (P/N M.1302.7099) are available from Kollmorgen.

- a. As an Output, indicates that the AC Input Power to the drive is OK. As an Input, instructs the drive to run even though AC Input Power is not present. This is typically used when two drives share bus power that is provided by the drive connected to AC Input Power. See [section A.1 on page 353](#) for more information.
- b. As an Output, indicates that the drive’s Shunt Output is active. As an Input, instructs the drive to activate its Shunt Output. Whenever the Shunt On signal is active (24Vdc nominal), the user-supplied shunt resistor (installed between Ba+ and Ba-) is connected across the DC bus. See [section A.1 on page 353](#) for more information.

CAUTION
<p>A possible ignition hazard within the MMC 460V Smart Drives exists if excessive current is drawn from the 24 VDC powering the MMC Smart Drive. To prevent this possibility (due to improper wiring or 24 VDC supply failure), a fuse should be used in series with the 24 VDC to the MMC Smart Drive. Specifically, a 4 A max. “UL248 Series” fuse should be used. In addition, the 24 VDC shall be supplied by an isolating source such that the maximum open circuit voltage available to the MMC Smart Drive is not more than 30 VDC.</p>

8.2.3.4 Motor Brake Connector (X101)

Table 8-13: 460V Size 3 Motor Brake Connector (X101)					
Signal Type	Signal Description	Pin	Connector Label	In/Out	Connector
Power	24 VDC brake input power	1	+24VBRK	In	<p style="text-align: center;">Top</p>
Brake control	Brake connections	2	Brake +	Out	
		3	Brake -	In	
Power	24 VDC common (supply and magnet)	4	24VCOM	Out	
Not Used.		5	N/C	Not Used	
		6			

Note: A 6-pin cage-clamp mating connector is included with the drive. Additional connectors (P/N M.1302.7099) are available from Kollmorgen.

Figure 8-6: Wiring Example for X101 Connector

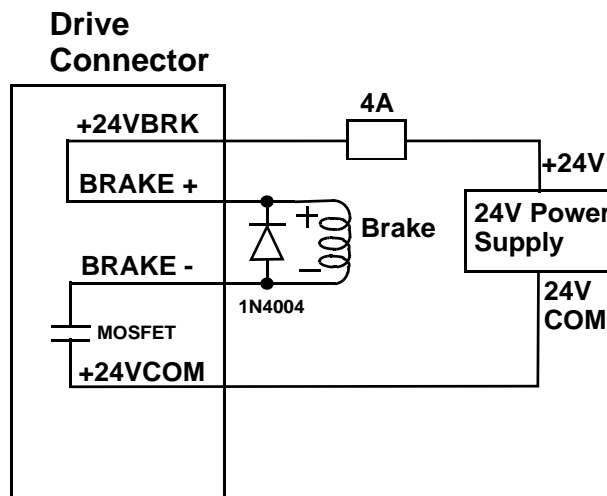

8.2.4 Size 4 Power Section Connectors

This section describes in detail the connectors located on the Power Section of the Size 4 drives.

The functionality and descriptions for the switches and connectors on the Control Section of the 460V MMC Smart Drives are the same as those on the 230V MMC Smart Drive. Refer to [section 7.1 on page 164](#) for more information.

Figure 8-7: Connectors on the Size 4 460V Drive

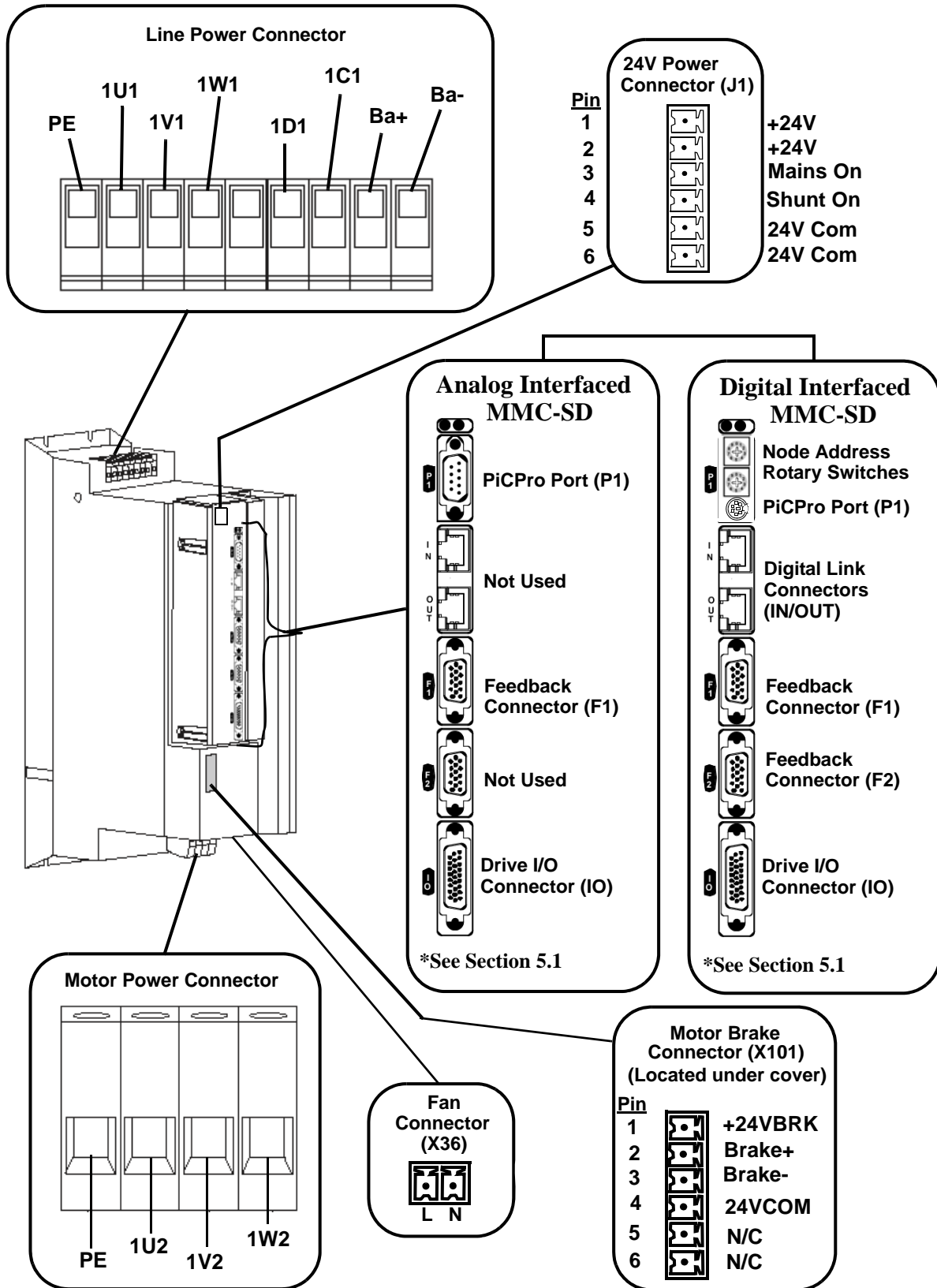

8.2.4.1 AC Power Connector

Table 8-14: 460V Size 4 AC Power Connector			
Signal Type	Signal Description	Connector Label	In/Out
Ground	Protective Ground (Earth)	PE	Out
Power	Three phase AC input power in to drive ^a	1U1	In
		1V1	
		1W1	
DC Bus Power	Direct DC bus connection	1D1 (ZK-)	Out
		1C1 (ZK+)	
	External Shunt Resistor used to dissipate energy returned to the drive from motor	Ba+	Out
		Ba-	

a. See important note regarding Input Power Phasing below

NOTE

When wiring Input Power to the drive, proper phasing is required. Specifically, it is necessary that U leads V, and V leads W. Typically, L1, L2, and L3 as found in a standard electrical fuse/disconnect box are properly phased left-to-right. Connect L1 to U, L2 to V, and L3 to W. If, when the drive is powered up and enabled, the drive indicates an Error 35 (Drive Power Module Fault, as indicated on the Drive Status Light and in PiCPro), remove power from the drive, and swap the U and V connections.

NOTE

The shunt resistor (if installed) across Ba+ and Ba- will be connected across the DC bus when the DC bus reaches the “shunt switch threshold” as shown in the specification table; or when the “Shunt On” input on the J1 connector is active.

NOTE

If a 460V drive is connected to 220V to run a 220V motor, enable the “220V Shunt on 440V Drive” feature using PiCPro, connect GPOUT3 on the Drive I/O (IO) connector to the “Shunt On” input on the J1 connector, and install the appropriate shunt resistor across the Ba+ and Ba- terminals. The shunt resistor will be applied across the DC bus when the DC bus voltage rises above 415 volts, and will be removed when the DC bus voltage falls below 400 volts.

8.2.4.2 Motor Connector

Table 8-15: 460V Size 4 Motor Connector

Signal Type	Signal Description	Connector Label	In/Out	Connector
Ground	Protective Ground (Earth)	PE	Out	
Motor	Power U-phase from the drive to the motor	1U2	Out	
	Power V-phase from the drive to the motor	1V2	Out	
	Power W-phase from the drive to the motor	1W2	Out	

8.2.4.3 24V Power Connector (J1)

Table 8-16: 460V Size 4 24V Power Connector (J1)

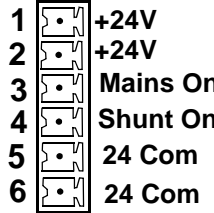
Signal Type	Signal Description	Pin	Connector Label	In/Out	Connector
Power	24 VDC input power	1	+24V	In	Top 
		2	+24V		
24V Logic Input/Output	See footnote ^a	3	Mains On	In/Out	
24V Logic Input/Output	See footnote ^b	4	Shunt On	In/Out	
Power	24 VDC input common to the drive.	5	24V Com	In	
		6	24V Com		

Note: A 6-pin cage-clamp mating connector is included with the drive. Additional connectors (P/N M.1302.7099) are available from Kollmorgen.

- a. As an Output, indicates that the AC Input Power to the drive is OK. As an Input, instructs the drive to run even though AC Input Power is not present. This is typically used when two drives share bus power that is provided by the drive connected to AC Input Power. See [section A.1 on page 353](#) for more information.
- b. As an Output, indicates that the drive’s Shunt Output is active. As an Input, instructs the drive to activate its Shunt Output. Whenever the Shunt On signal is active (24Vdc nominal), the user-supplied shunt resistor (installed between Ba+ and Ba-) is connected across the DC bus. See [section A.1 on page 353](#) for more information.

CAUTION
<p>A possible ignition hazard within the MMC 460V Smart Drives exists if excessive current is drawn from the 24 VDC powering the MMC Smart Drive. To prevent this possibility (due to improper wiring or 24 VDC supply failure), a fuse should be used in series with the 24 VDC to the MMC Smart Drive. Specifically, a 4 A max. “UL248 Series” fuse should be used. In addition, the 24 VDC shall be supplied by an isolating source such that the maximum open circuit voltage available to the MMC Smart Drive is not more than 30 VDC.</p>

8.2.4.4 Motor Brake Connector (X101)

Table 8-17: 460V Size 4 Motor Brake Connector (X101)					
Signal Type	Signal Description	Pin	Connector Label	In/Out	Connector
Power	24 VDC brake input power	1	+24VBRK	In	<p style="text-align: center;">Top</p>
Brake control	Brake connections	2	Brake +	Out	
		3	Brake -	In	
Power	24 VDC common (supply and magnet)	4	24VCOM	Out	
Not Used.		5	N/C	Not Used	
		6			

Note: A 6-pin cage-clamp mating connector is included with the drive. Additional connectors (P/N M.1302.7099) are available from Kollmorgen.

Figure 8-8: Wiring Example for X101 Connector

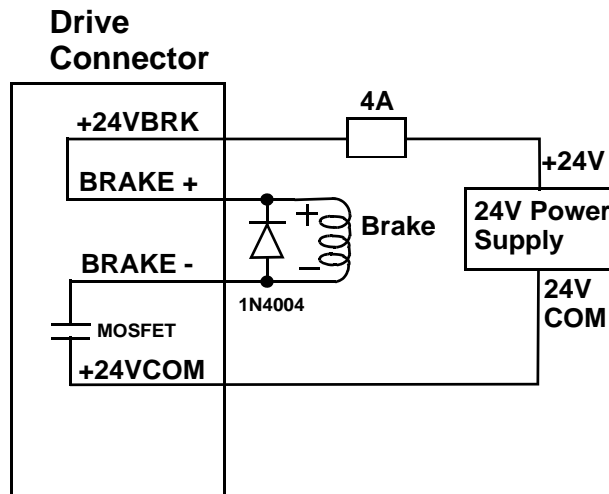

8.2.4.5 Fan Connector (X36)

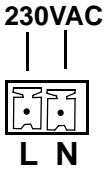
Table 8-18: 460V Size 4 Fan Connector (X36)					
Signal Type	Signal Description	Pin	Connector Label	In/Out	Connector
Power	230VAC Line for powering the fan	1	L	In	<p>230VAC</p>  <p>L N</p>
Power	230VAC Neutral for powering the fan	2	N	In	

8.3 Typical 460V Drive Connection Layout

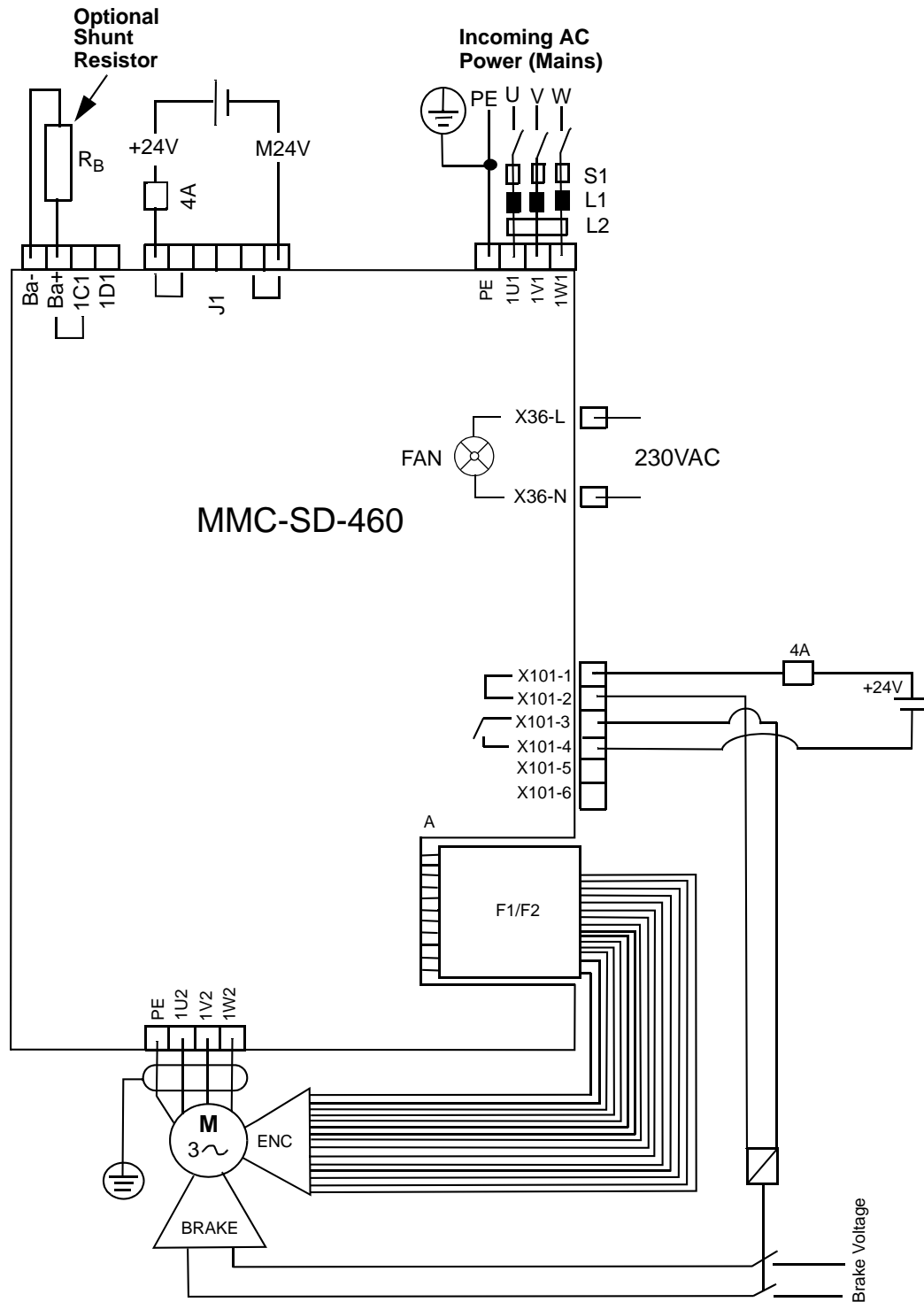

8.4 Specifications - 460V MMC Smart Drive)

8.4.1 Common Data for Size 1, 2, 3, 4, 5 (All Models)

General Drive Data	
Minimum wire size for input power wires	1.5mm ² (16 AWG) 75° C copper
Maximum tightening torque for power wire terminals	1.25Nm (11 in-lbs.)
Commutation	3 Phase Sinusoidal, Space Vector Modulated (SVM)
Current Regulator	Digital PI 125 µsec update rate
Velocity Regulator	Digital PID - 250 µsec update rate
General Operating Data	
Operating Temperature Range (MMC-SD-1.3, -2.4, -4.0, -6.0, -8.0, -12.0, -16.0, -24.0)	7° C to 50° C (45° F to 122° F)
Operating Temperature Range (MMC-SD-30.0, -42.0, -51.0, -65.0)	7° C to 55° C (45° F to 131° F). Derate 3% per° C above 40° C.
Storage Temperature Range	-30° C to 70° C (-22° F to 158° F)
Humidity	5% to 95% non-condensing
Altitude	1500m (5000ft) Derate 3% for each 300 m above 1500m
Vibration Limits (per IEC 68-2-6) Operating/Non-operating	10-57Hz (constant amplitude .15mm) 57 - 2000Hz (acceleration 2g)
Shock (per IEC 68-2-27) Non-operating	15g/11msec per axis
F1 and F2 Feedback Inputs	
Input receiver type	Maxim 3098 A quad B differential RS422 receiver
Encoder signals	Differential quadrature
Input threshold	±200mV
Input termination	150Ω, provided internal
Maximum input voltage	5Vpp differential -10 to +13.2V common mode
Maximum input signal frequency	720KHz (2.88 M feedback unit count rate)

General Purpose Inputs	
Configuration	<ul style="list-style-type: none"> • 8 optically isolated 24V DC inputs • Active high • 6 are current sourcing only (current flow into input) • 2 are sink or source
Guaranteed On	15VDC
Guaranteed Off	5VDC
Time delay on	1ms max.
Time delay off	1ms max.
Input voltage	Nominal 24VDC, maximum 30VDC
General Purpose Outputs	
Configuration	<ul style="list-style-type: none"> • 4 optically isolated 24VDC outputs • Active high • Current sourcing only (current into load) • Short circuit and overload protected
Maximum current	50mA per output
Voltage range	24VDC +15%-10%
Time delay on for resistive loads	50µsec. max
Time delay off for resistive loads	50µsec. max
Leakage current in off state	0.5mA max
Command Input/Output	
Command Input	Analog velocity or torque, 0 to $\pm 10V$ 14 bit effective resolution
Digital Link In/Out Ports (Digital Interfaced MMC-SD only)	
"In" port	Sends and receives high speed data to and from connected MMC-SD's "Out" port.
"Out" port	Sends and receives high speed data to and from connected MMC-SD's "In" port.
Cable Type	Shielded, Straight Pinned, CAT5 or better (CAT5e, CAT6, etc.)
Maximum Cable Length	30m (98.4 ft)

Drive I/O Connector Encoder Emulation Output		
F1 Motor Feedback Type	Input Limit	Encoder Emulation Output (A quad B Differential Output)
Incremental Encoder	720KHz 2.88 M counts/sec.	The motor encoder A/B/I inputs are electrically buffered and retransmitted via the Drive I/O connector.
High Resolution Encoder	100KHz 400K counts/sec.	The encoder SIN/COS signals are electrically squared and retransmitted as A/B. The index mark "I" is synthesized by the drive control DSP. Absolute position information is not available via the Encoder Emulation Output.
Resolver	500RPS 2.00M counts/sec.	The field-installable resolver interface module converts the motor resolver to 1024 lines/4096 counts per revolution of A/B encoder output. The module synthesizes the index mark "I" once per revolution of the resolver. Absolute position information is not available via the Encoder Emulation Output.
Conformity		
CE Marked	Conforms to Low Voltage Directive 73/23/EEC (amended by 93/68/EEC) and EMC Directive 89/336/EEC (amended by 92/31/EEC and 93/68/EEC). Conformance is in accordance with the following standards: EN 50178 and EN61800-3	
UL and C/UL Listed	E233454	

8.4.2 Physical/Electrical Data for 460V Size 1 Smart Drives

	Model	
	MMC-SD-1.3-460 (-D)	MMC-SD-2.4-460 (-D)
Part Numbers		
Analog	M.1302.5093	M.1302.5094
Digital, no BiSS	M.1302.8133	M.1302.8134
Digital, BiSS	M.3000.0464	M.3000.0465
Digital, Biss, EF ^a	M.3000.1077	M.3000.0465
		M.3000.1092
Physical		
Weight	10 lbs.	
Electrical Specifications		
AC Input Specifications		
Wire Size	1mm ² to 2.5mm ² (16-12AWG)	
Screw Torque	Not specified	
Input Configuration	Industrial system with direct low impedance earthed star point (TN or TT mains). Do not use with IT mains or corner grounded delta.	
Inductance	.4% (min) to 4% (max)	
Nominal Input Power	1.94kVA	3.33kVA
Input Voltage	207-528 VAC (400 VAC nominal), 3 Phase	
Input Frequency	47-63Hz	
Nominal Input	2.44A RMS	4.18A RMS
NOTE: Nominal Input Current is specified for nominal input voltage of 460 VAC.		
Maximum Inrush	4.56A RMS	7.81A RMS
Power Loss	34W	60W
AC Output Specifications		
Continuous Output Current RMS (0-Peak)	2.1A (3.0A)	3.9A (5.5A)
Continuous Output Power		
Input = 230 VAC	.65kW	1.2kW
Input = 460 VAC	1.3kW	2.4kW
Peak Output Current (0-Peak)	6.0A	11.0A
Output Frequency	0-450Hz	

DC Input Power Specifications (24VDC)		
Input Voltage Range	24VDC +15% -10%	
Typical Input Current	700mA	
Typical Input Wattage	17W	
Inrush Current	4A for 10ms	
Internal Holding Brake Driver		
Maximum Current	0.5A	
Energy Absorbtion Specifications		
DC Bus Capacitance (Internal)	110 μ F	240 μ F
Shunt Switch Threshold	780VDC	
Joules available for energy absorption		
230V motor w/ 230V line input	3 joules	7 joules
460V motor w/ 230V line input	28 joules	60 joules
460V motor w/ 460V line input	10 joules	22 joules
External Shunt		
Maximum shunt resistor current	5.9A (AC)	
Minimum shunt resistor	130 Ω	
Maximum shunt resistor power at minimum shunt resistor	4.5kW	5kW

a. EF indicates that this drive has the Enhanced Feedback feature

8.4.3 Physical/Electrical Data for 460V Size 2 Smart Drives

	Model		
	MMC-SD-4.0-460 (-D)	MMC-SD-6.0-460 (-D)	MMC-SD-8.0-460 (-D)
Part Numbers Analog Digital, no BiSS Digital, BiSS Digital, Biss, EF ^a	M.1302.5095 M.1302.8135 M.3000.0466 M.3000.1093	M.1302.5096 M.1302.8136 M.3000.0467 M.3000.1094	M.1302.5097 M.1302.8137 M.3000.0468 M.3000.1095
Physical			
Weight	16 lbs.		
Electrical Specifications			
AC Input Specifications			
Wire Size	1mm ² to 2.5mm ² (16-12AWG)		
Screw Torque	0.6 Nm		
Input Configuration	Industrial system with direct low impedance earthed star point (TN or TT mains). Do not use with IT mains or corner grounded delta.		
Inductance	.4% (min) to 4% (max)		
Nominal Input Power	5.6kVA	8.6kVA	11.8kVA
Input Voltage	207-528 VAC (400 VAC nominal), 3 Phase		
Input Frequency	47-63Hz		
Nominal Input Current	7A RMS	10.8A RMS	14.8A RMS
NOTE: Nominal Input Current is specified for nominal input voltage of 460 VAC. Approximate Current for input voltages between 400 and 480 VAC = (listed current) x input voltage/460			
Maximum Inrush Current	13.2A RMS	20.2A RMS	27.7A RMS
Power Loss	102W	150W	204W

AC Output Specifications			
Continuous Output Current RMS (0-Peak)	6.4A (9.0A)	9.6A (13.5A)	12.7A (18.0A)
Continuous Output Power			
Input = 230 VAC	2.0kW	3.0kW	4.0kW
Input = 460 VAC	4.0kW	6.0kW	8.0kW
Peak Output Current (0-peak)	18.0A	27.0A	36.0A
Output Frequency	0Hz to 450Hz		
Internal Holding Brake Driver			
Maximum Current	0.5A		
DC Input Power Specifications (24VDC)			
Input Voltage Range	24VDC +15% -10%		
Typical Input Current	1050mA		
Typical Input Wattage	25W		
Inrush Current	4A for 10ms		
Energy Absorbtion Specifications			
DC Bus Capacitance (Internal)	470 μ F	705 μ F	
Shunt Switch Threshold	780VDC		
Joules available for energy absorption			
230V motor w/230V line input	13 joules	19 joules	
460V motor w/230V line input	188 joules	177 joules	
460V motor w/460V line input	44 joules	66 joules	

External Shunt			
Maximum shunt resistor current	9A (AC)	9A (AC)	9A (AC)
Minimum shunt resistor	86Ω	60Ω	44Ω
Maximum shunt resistor power at minimum shunt resistor	7kW	10kW	14kW

a. EF indicates that this drive has the Enhanced Feedback feature

8.4.4 Physical/Electrical Data for 460V Size 3 Smart Drives

	Model			
	MMC-SD-12.0-460 (-D)	MMC-SD-16.0-460 (-D)	MMC-SD-24.0-460 (-D)	MMC-SD-30.0-460-D
Part Numbers				
Analog	M.1302.5098	M.1302.5099	M.1302.5100	M.3000.0545
Digital, no BiSS	M.1302.8138	M.1302.8139	M.1302.8140	N/A
Digital, BiSS	M.3000.0469	M.3000.0470	M.3000.0471	M.3000.0021
Digital, Biss, EF ^a	M.3000.1096	M.3000.1097	M.3000.1098	M.3000.1099
Physical				
Weight	35 lbs.			
Electrical Specifications				
AC Input Specifications				
Wire Size	0.5mm ² to 10mm ² (20-6AWG)			
Screw Torque	1.56 Nm			
Input Configuration	Industrial system with direct low impedance earthed star point (TN or TT mains). Do not use with IT mains or corner grounded delta.			
Inductance	2.4% (min) to 4% (max)			
Nominal Input Power	13.3kVA	16.8kVA	26.3 kVA	36.7 kVA
Input Voltage	207-528 VAC (400 VAC nominal), 3 Phase			
Input Frequency	47-63Hz			
Nominal Input Current	16.7A RMS	21.1A RMS	33.1A RMS	44.0A RMS
NOTE: Nominal Input Current is specified for nominal input voltage of 460 VAC. Approximate Current for input voltages between 400 and 480 VAC = (listed current) x 460/input voltage				
Maximum Inrush Current	32.2A RMS	39.2A RMS	61.8A RMS	CF ^b
Power Loss	300W	390W	600W	840W

AC Output Specifications				
Continuous Output Current RMS (0-Peak)	19.5A (27.5A)	25.8A (36.5A)	38.9A (55.0A)	(49.0A (69.3A))
Continuous Output Power				
Input = 230 VAC	6.0kW	8.0kW	12.0kW	15.0kW
Input = 460 VAC	12.0kW	16.0kW	24.0kW	30.0kW
Peak Output Current (0-peak)	55.0A	73.0A	110.0A	110.0A
Output Frequency	0Hz to 450Hz			
Internal Holding Brake Driver				
Maximum Current	0.5A		1.0A	
DC Input Power Specifications (24VDC)				
Input Voltage Range	24VDC +15% -10%			
Typical Input Current	1750mA			
Typical Input Wattage	42W			
Inrush Current	4A for 10ms			
Energy Absorption Specifications				
DC Bus Capacitance (Internal)	820 μ F	1230 μ F	1640 μ F	2000 μ F
Shunt Switch Threshold	780VDC			
Joules available for energy absorption				
230V motor w/ 230V line input	22 joules	33 joules	45 joules	553 joules
460V motor w/ 230V line input	206 joules	309 joules	412 joules	502 joules
460V motor w/ 460V line input	76 joules	114 joules	152 joules	185 joules

External Shunt		
Maximum shunt resistor current	36A (AC)	50A (AC)
Minimum shunt resistor	22Ω	16Ω
Maximum shunt resistor power at minimum shunt resistor	29kW	40kW

- a. EF indicates that this drive has the Enhanced Feedback feature
- b. Consult Factory

8.4.5 Physical/Electrical Data for 460V Size 4 Smart Drives

	Model		
	MMC-SD-42.0-460-D	MMC-SD-51.0-460-D	MMC-SD-65.0-460-D
Part Numbers Analog Digital, BiSS Digital, Biss, EF ^a	M.3000.0546 M.3000.0022 M.3000.1100	M.3000.0547 M.3000.0023 M.3000.1101	M.3000.0548 M.3000.0024 M.3000.1102
Physical			
Weight	59 lbs.		
Electrical Specifications			
AC Input Specifications			
Wire Size	16mm ² to 50mm ² (6-0AWG)		
Screw Torque	8 Nm		
Input Configuration	Industrial system with direct low impedance earthed star point (TN or TT mains). Do not use with IT mains or corner grounded delta.		
Inductance	2.4% (min) to 4% (max)		
Nominal Input Power	48.5kVA	58.2kVA	72.1kVA
Input Voltage	207-528 VAC (400 VAC nominal), 3 Phase		
Input Frequency	47-63Hz		
Nominal Input Current	58A RMS	72A RMS	95A RMS
NOTE: Nominal Input Current is specified for nominal input voltage of 460 VAC. Approximate Current for input voltages between 400 and 480 VAC = (listed current) x 460/input voltage			
Maximum Inrush Current	CF ^b	CF	CF
Power Loss	1080W	1350W	1740W

AC Output Specifications			
Continuous Output Current RMS (0-Peak)	66.0A (93.3A)	83.2A (117.4A)	108.0A (152.7A)
Continuous Output Power			
Input = 230 VAC	21.0kW	25.1kW	32.5kW
Input = 460 VAC	42.0kW	51.0kW	65.0kW
Peak Output Current (0-peak)	147A	189A	209A
Output Frequency	0Hz to 450Hz		
Internal Holding Brake Driver			
Maximum Current	4.0A		
DC Input Power Specifications (24VDC)			
Input Voltage Range	24VDC +15% -10%		
Typical Input Current	3.2A		
Typical Input Wattage	77W		
Inrush Current	Not Specified		
Energy Absorbtion Specifications			
DC Bus Capacitance (Internal)	1880 μ F	2350 μ F	3055 μ F
Shunt Switch Threshold	780VDC		
Joules available for energy absorption			
230V motor w/ 230V line input	50.4joules	63.1joules	82joules
460V motor w/ 230V line input	472joules	591joules	768joules
460V motor w/ 460V line input	173joules	218joules	284joules

External Shunt			
Maximum shunt resistor current	67A (AC)	100A (AC)	100A (AC)
Minimum shunt resistor	12Ω	8Ω	8Ω
Maximum shunt resistor power at minimum shunt resistor	53kW	80	80kW
Fan (X36 Connector)			
Input Voltage	230VAC (nominal), 207VAC to 253VAC, 50/60HZ		
Input Current	1A Max		
Power Loss	87W		

- a. EF indicates that this drive has the Enhanced Feedback feature
- b. Consult Factory

8.5 Dimensions for the 460V Smart Drives

Figure 8-9: Size 1 460V Smart Drive - Front View

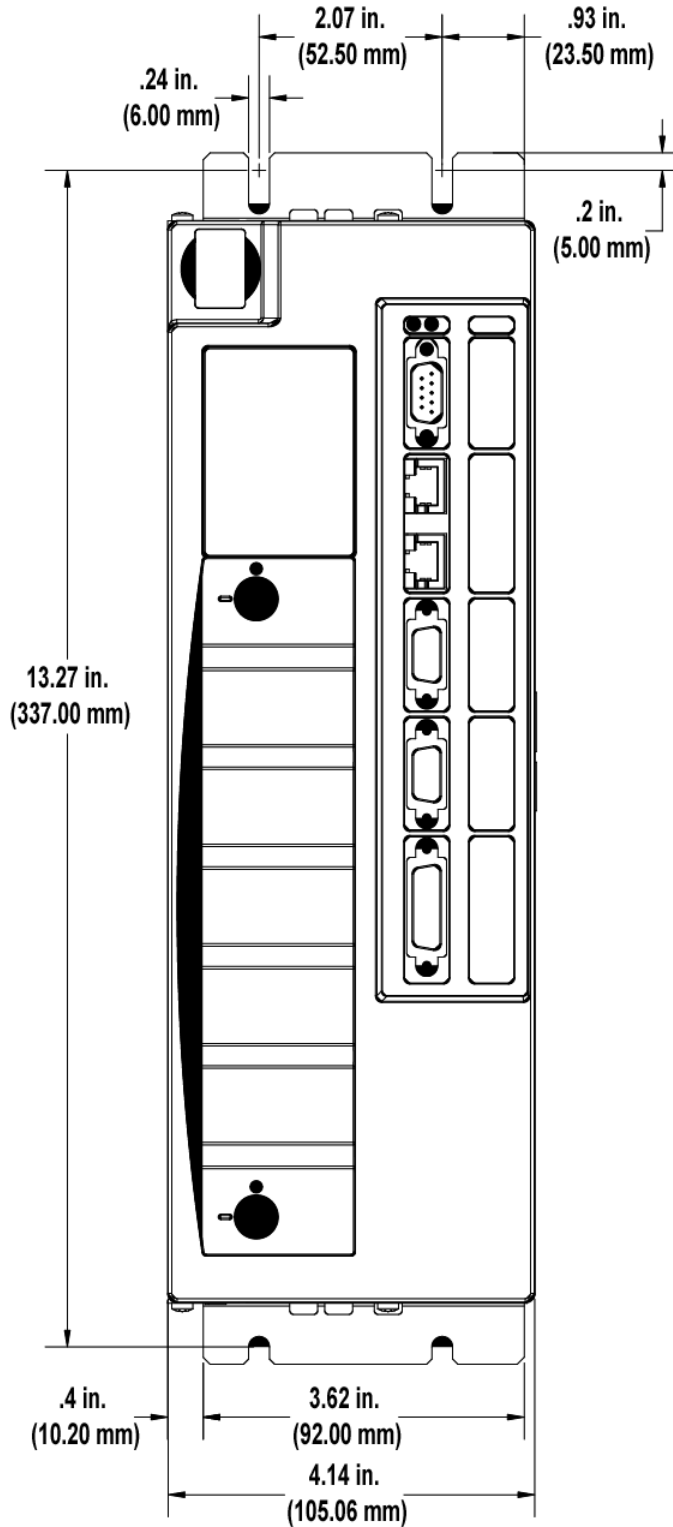

Figure 8-10: Size 1 460V Smart Drive - Side View

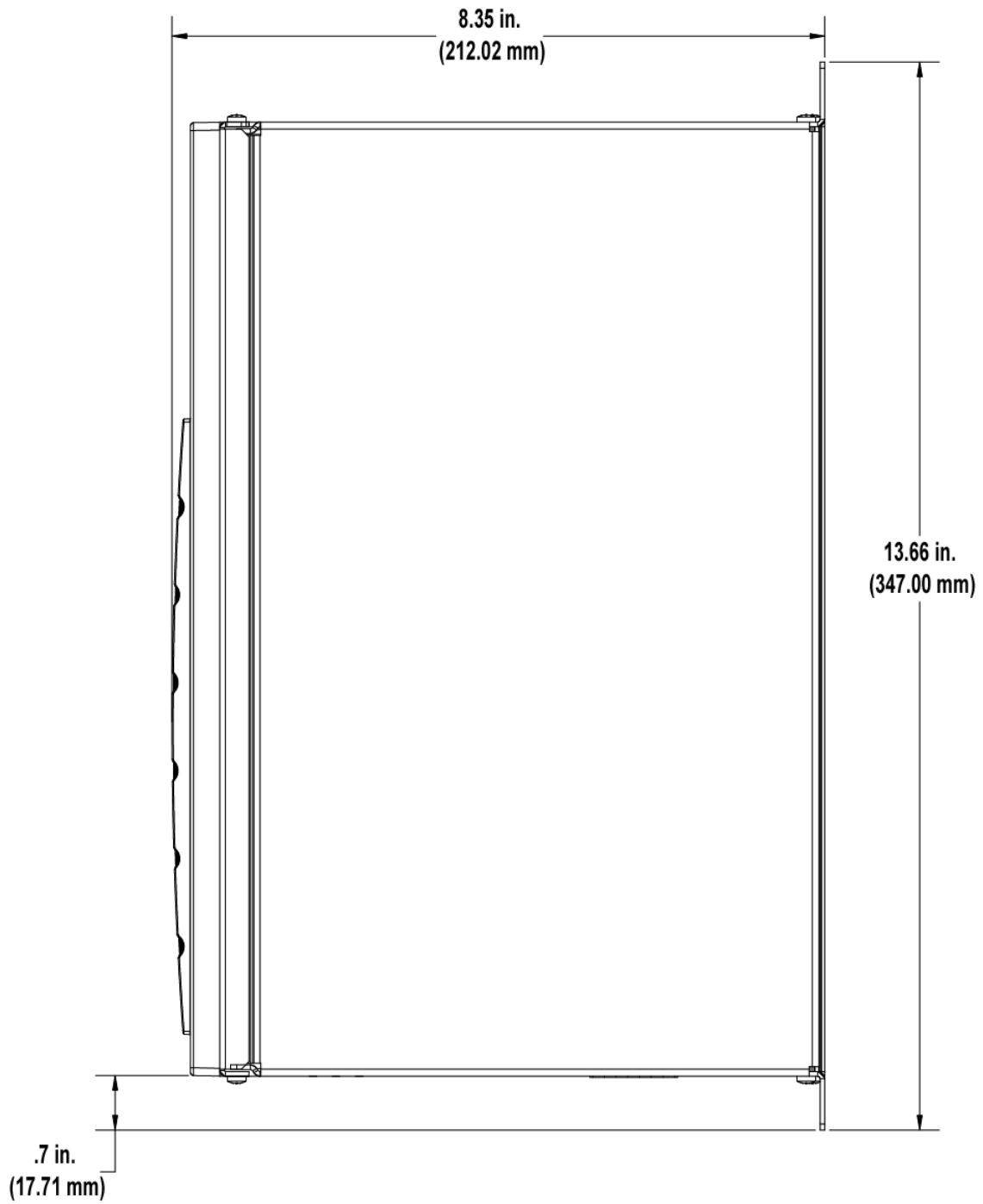

Figure 8-11: Size 2 460V Smart Drive - Front View

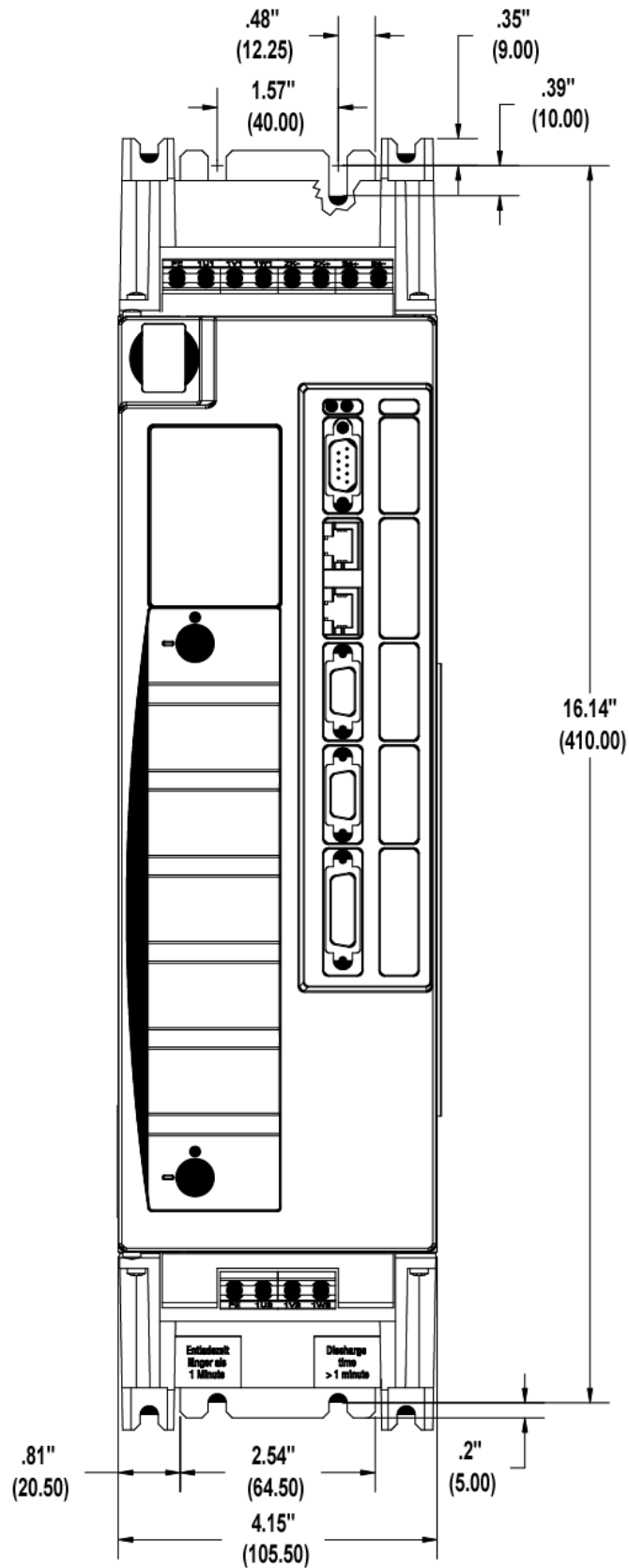

Figure 8-12: Size 2 460V Smart Drive - Side View

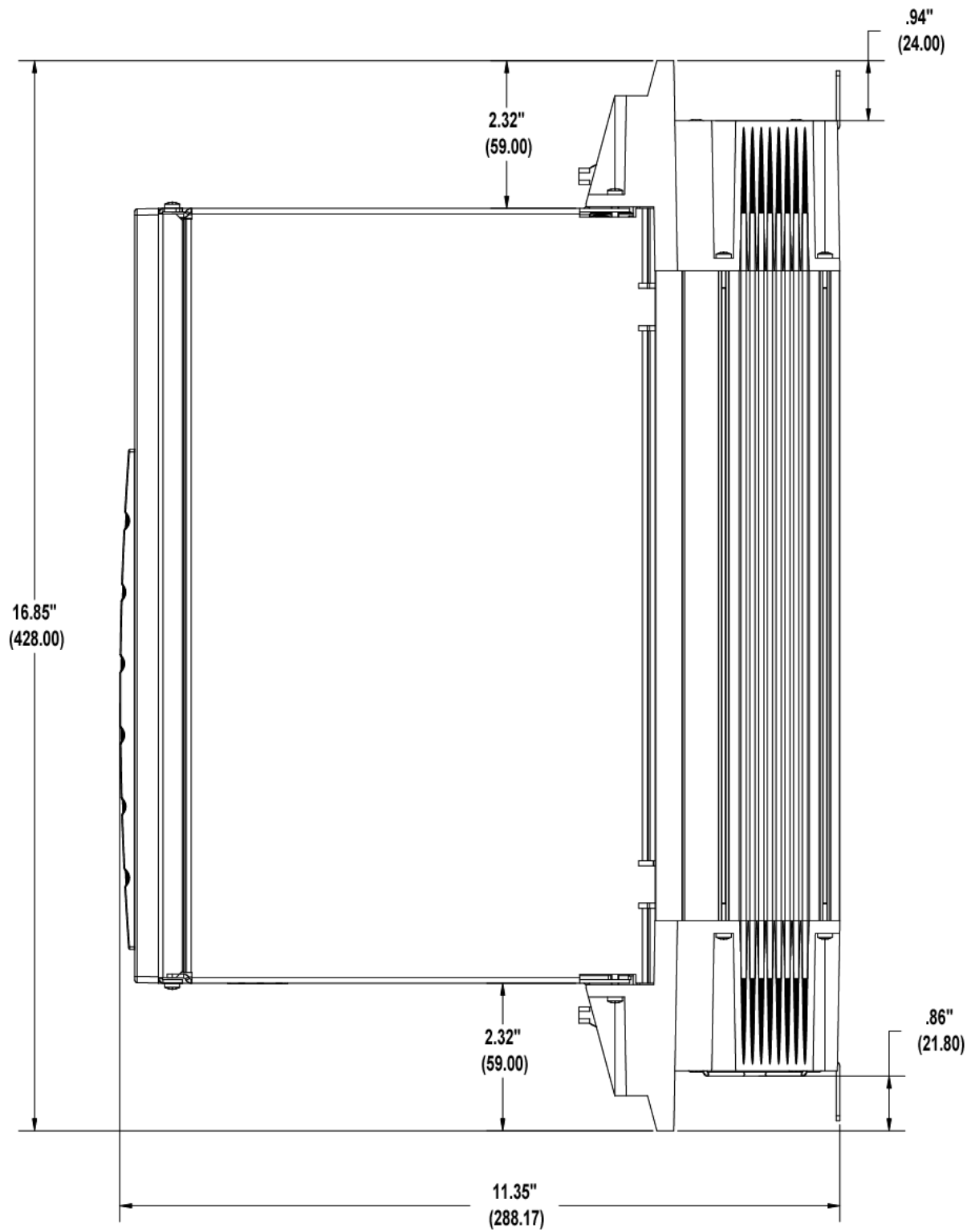

Figure 8-13: Size 3 460V Smart Drive - Front View

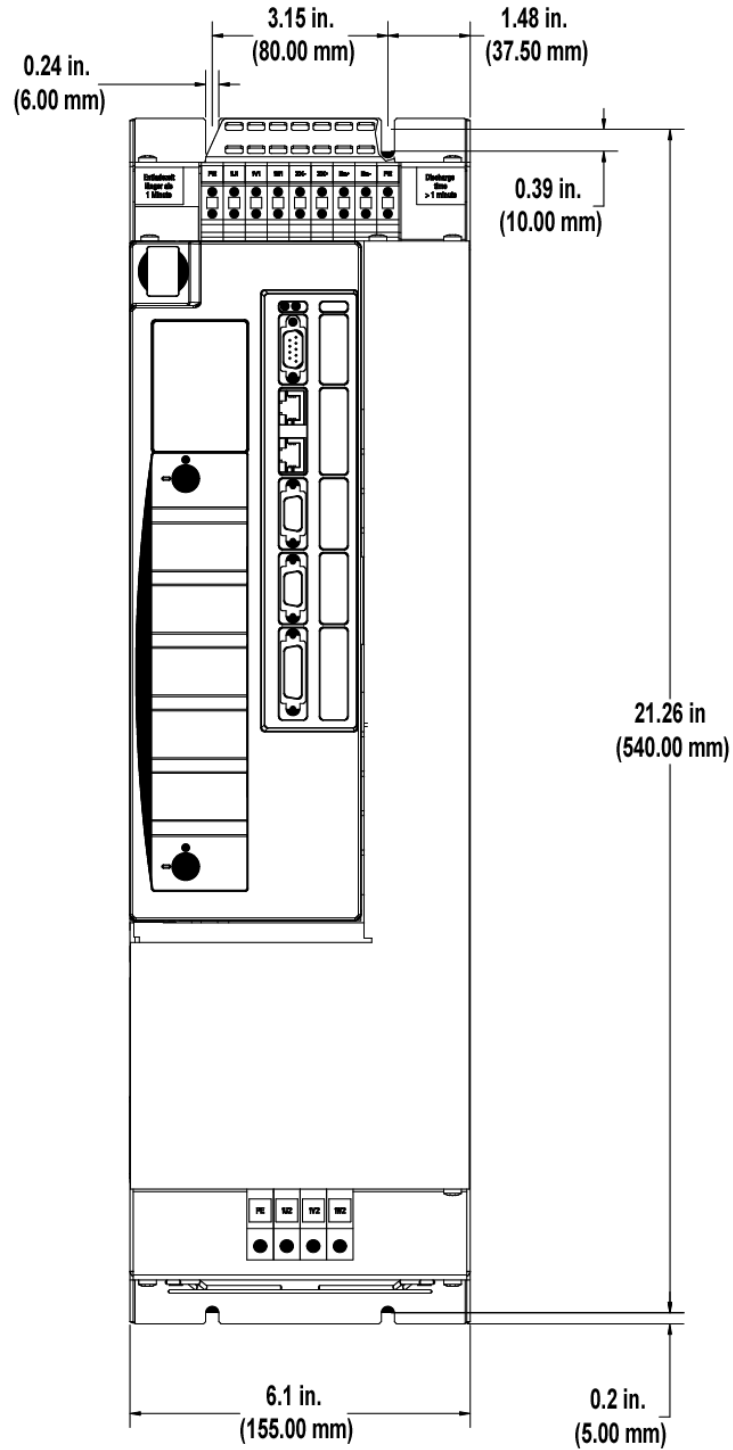

Figure 8-14: Size 3 460V Smart Drive - Side View

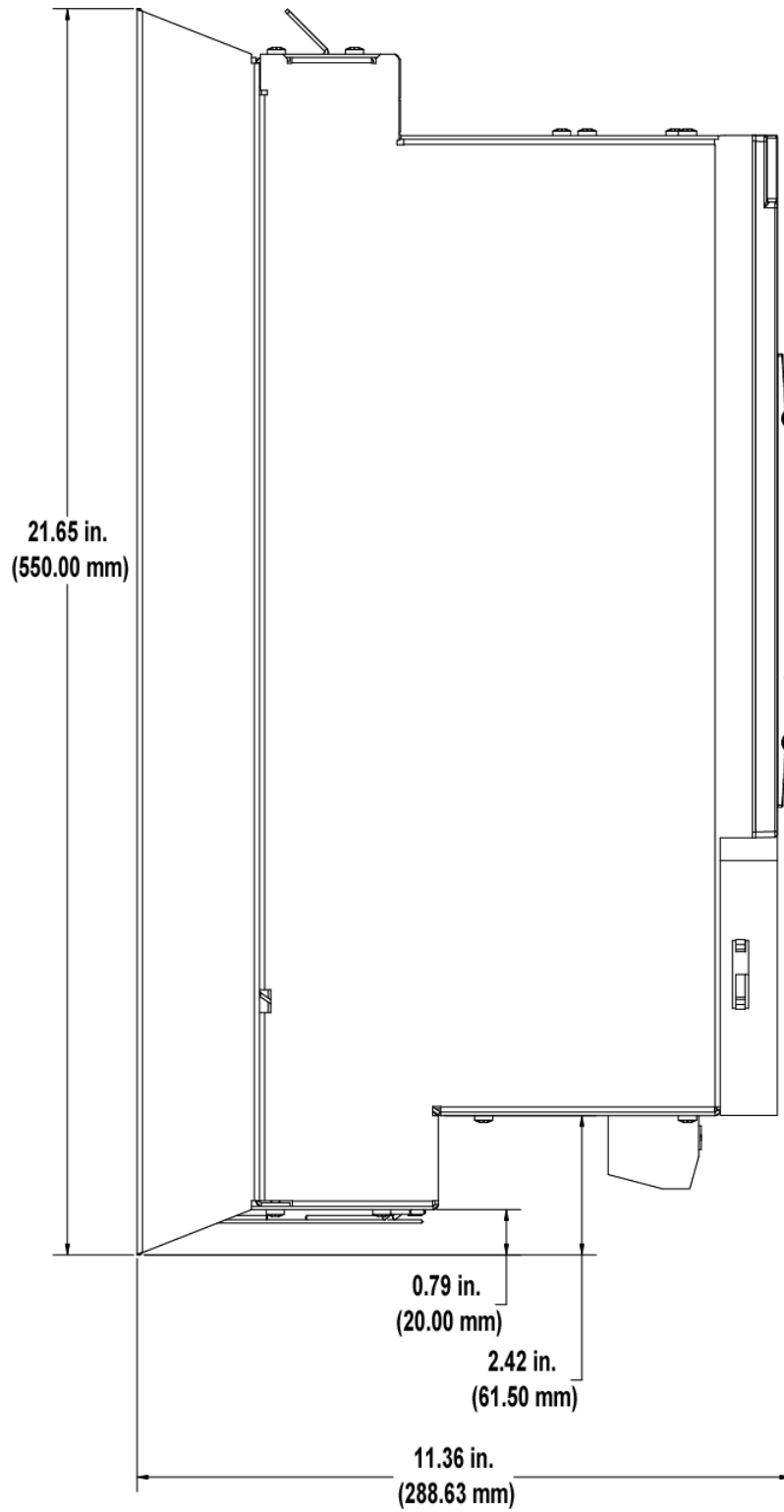

Figure 8-15: Size 4 460V Smart Drive - Front View

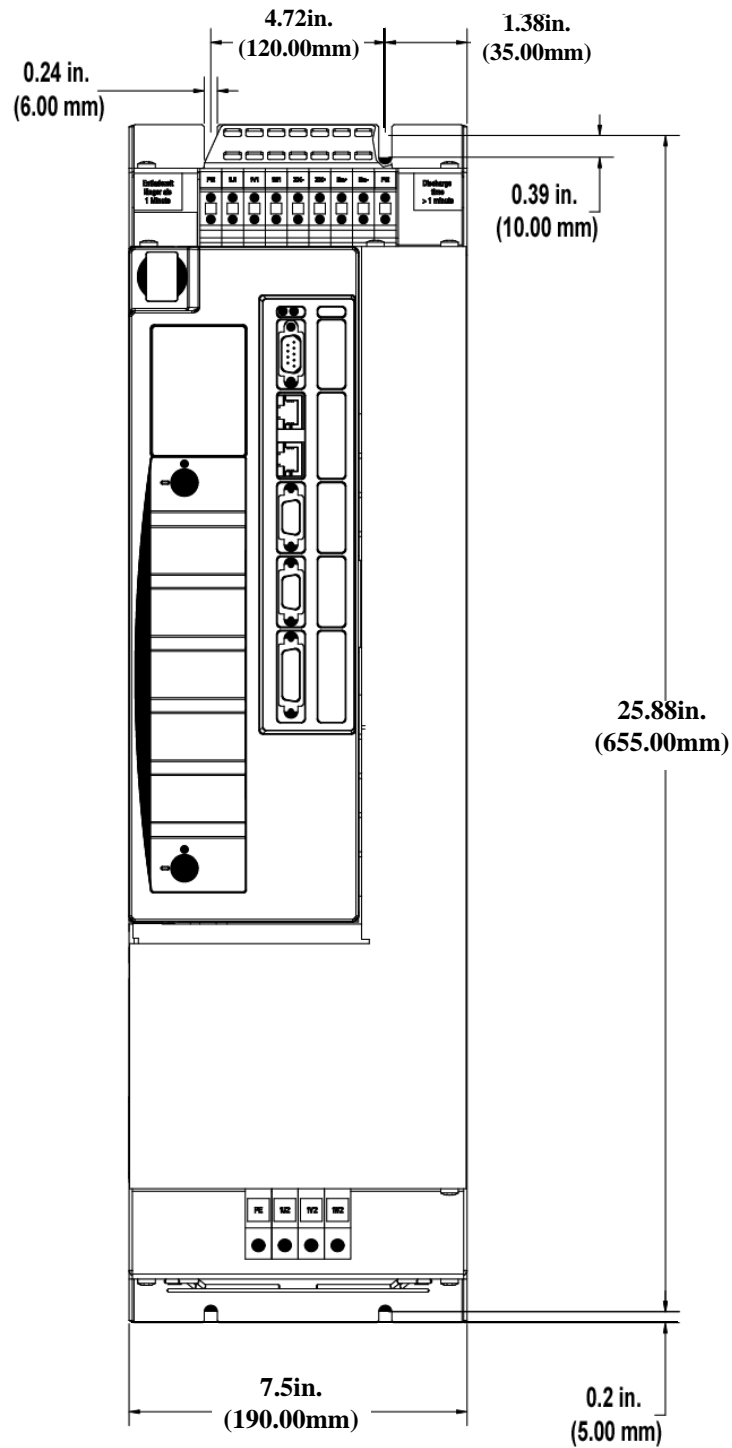
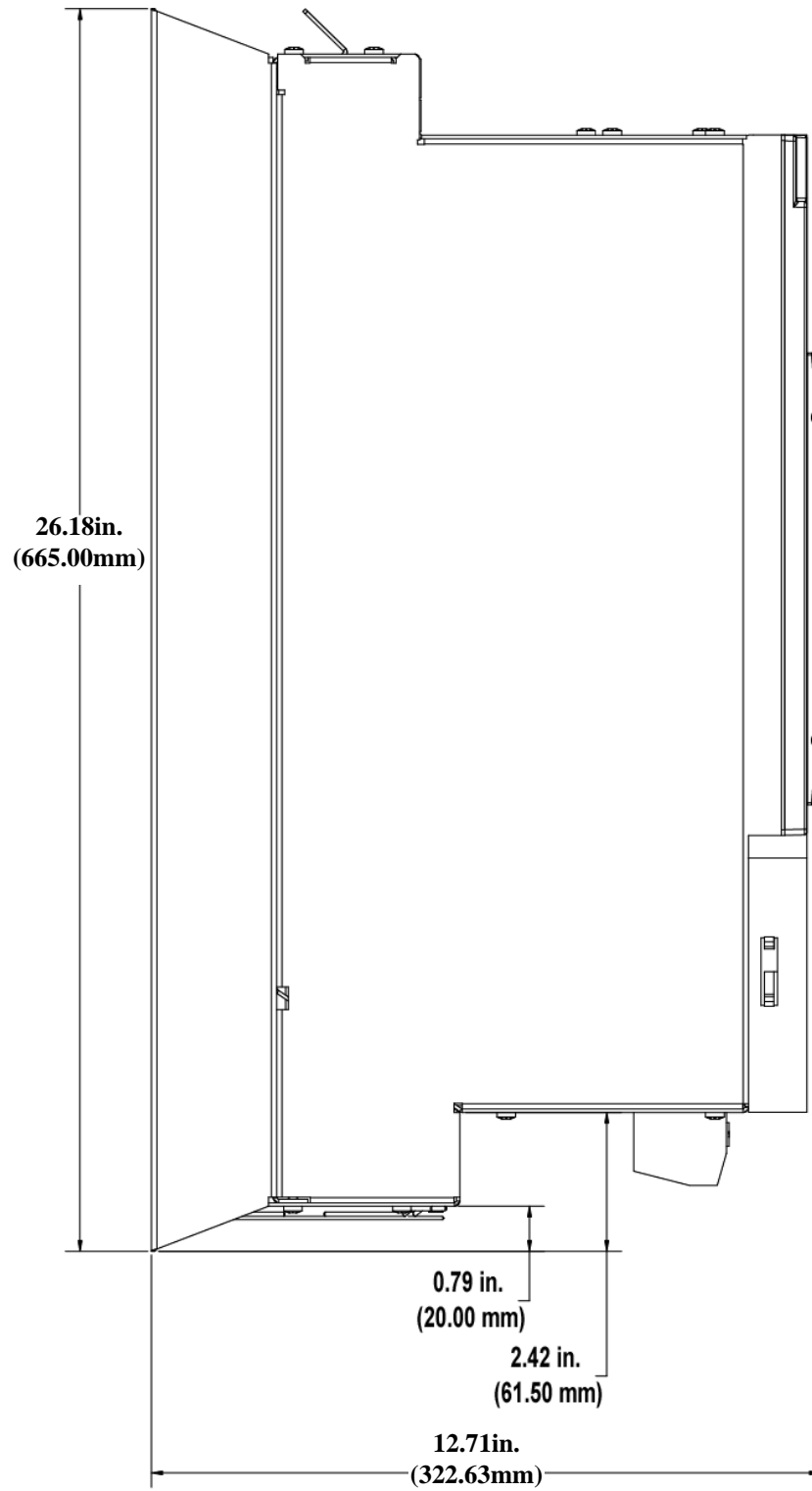

Figure 8-16: Size 4 460V Smart Drive - Side View



9 S200-DLS Drive

This chapter only pertains to the S200-DLS Drive, not to the MMC Smart Drive.

The S200-DLS consists of a Base Unit with an S200 Digital Link Option Card installed. The combination of the two components is the S200-DLS Drive. The Base Unit is described in detail in Kollmorgen's S200 Base Unit Reference Manual, P/N M-SM-200-01, which can be found at http://www.kollmorgen.com/website/com/eng/products/drives/ac_servo_drives/s200_manuels.php. Please refer to the S200 Base Unit Reference Manual for Base Unit Specifications, Mounting information, Wiring information, etc. The Base Unit has the same Part Number as the Digital Link version, except that the -DLS is replaced with -VTS. For example, a S20360-DLS consists of an S20360-VTS Base Unit and an S200 Digital Link Option Card.

Any data or specification contained in this manual takes precedence over conflicting data or specifications found in the Base Unit manual.

CE ENCLOSURE REQUIREMENTS

In order to meet the requirements of the CE Directives, the S200-DLS drive(s) must be mounted within a grounded metal enclosure. Additional actions may also be required, as described in the S200 Base Unit Reference Manual, mentioned above.

BISS ENCODER SUPPORT

In order to use a BiSS encoder with the S200-DLS drive, the firmware within the drive must be Version 2.00 or later. In addition, the drive revision (as found on the drive label), must be as follows:

- S20260-DLS - Rev 0 or higher
- All others - Rev 3 or higher

Figure 9-1:

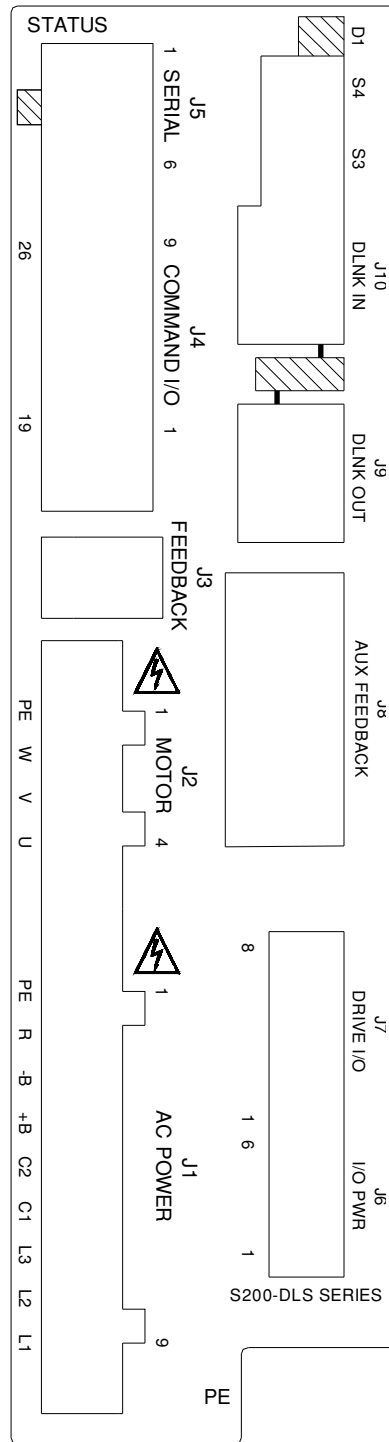

9.1 S200-DLS Option Card

The S200 Option Card is located on the right side of the S200-DLS Drive. This section explains in detail the various indicators and connectors located on the S200 Option Card.

9.1.1 LED Indicators

There are three LED Indicators on the front of the Option Card, as described in [Table 9-1](#).

LED	Color	Description
Diagnostic	Yellow	The Diagnostic LED (labeled "D1" on the front of the Drive), located in the top of the Option Card, serves as the Option Card Status indicator, and provides Option Card status and fault information.
Digital Link LEDs	Green	These LEDs, located between the "DLINK IN" and "DLINK OUT" connectors, provide Digital Link status information.

9.1.2 Diagnostic Indicator Details

The Diagnostic Indicator LED (labeled "D1" on the front of the Drive) performs various functions:

- When Control Power is applied to the Drive, the Diagnostic LED turns on briefly as the Option Card runs internal power-on diagnostics. If the diagnostics pass, the Diagnostic LED goes off.
- If the Diagnostic LED is flashing after the power-on diagnostics are complete, there is a problem with the Drive. See [section 11.2.4.1 on page 299](#) for blink code details.
- While the Drive is operating, the Option Card is constantly monitoring Drive operation and performance. If a Warning or Fault condition is detected, the Diagnostic LED will blink. See [section 11.2.4.1 on page 299](#) for blink code details.

9.1.3 Digital Link LEDs

There are two green LED indicators located between the "DLINK IN" and "DLINK OUT" connectors.

- The right-most LED is associated with the "DLINK IN" connector, and indicates that another "upstream" Digital Link device (Digital Link drive, Digital Control, Digital Link Accessory, etc.) is connected and successfully communicating with the Drive.
- The left-most LED is associated with the "DLINK OUT" connector, and indicates that the Drive is connected and successfully communicating with another "downstream" Digital Link device (Digital Link drive, Digital Link Accessory, etc.).

9.1.4 Node Address Rotary Switches

Two rotary switches are used to set the drive address. Rotate the switch to the desired address.

Addresses can be set to any number from 1 through 64. The top switch represents values of base ten. The bottom switch represents values of base 1.

As an example, rotating the top switch (S3) to a setting of 2 equals the value of 20 (2 x 10). Rotating the bottom switch (S4) to a setting of 5 equals the value of 5. The actual address setting is 25 (20 + 5).

Figure 9-2: Node Address Switches

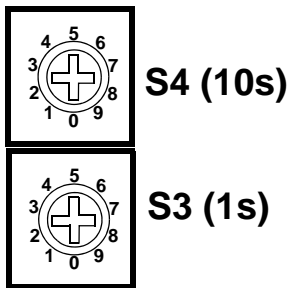

9.1.5 Digital Link Ports

The two 8-pin RJ-45 Digital Link Port connectors (labeled “J10 DLINK IN” and “J9 DLINK OUT” on the front of the Drive) provide communications between the S200-DLS and:

- another S200-DLS Drive
- a Digital Link Accessory (DL-DIU, Slice I/O Coupler, etc.)
- an MMC Smart Drive (including a Drive that contains a Drive Resident MMC Control)
- an MMC-DSA Control (MMC-DSA2, -DSA4, -DSA8, -DSA16)
- a Digital Standalone MMC Control (MMC-D32, -D64)

Also provided are two green “Link” lights located between the RJ-45 connectors. The right light will be on if there is a Drive or Digital Control connected to the “IN” port, and the left light will be on if there is a Drive connected to the “OUT” port.

A “straight-through” shielded cable must be used when connecting to another device. Connect the cable from the Drive’s “DLINK OUT” port to the next Digital Link Device’s “DLINK IN” port, or from the MMC Digital Control’s Digital Link port to the Drive’s “DLINK IN” port. Refer to the Standalone MMC Hardware Manual for Standalone Digital Control information.

- Pin descriptions for are provided in [Table 9-2](#)
- Pin assignments are provided in [Table 9-3](#)
- The available Digital Link Port to Digital Drive cables are described in [Table 9-4](#)

Digital Link Connector (IN/OUT) Signals		Pin	
Function	Notes	“In” Connector	“Out” Connector
Receive Data+/-	Receives data from connected drives.	1,2	3,6
Transmit Data +/-	Transmits data to connected drives.	3,6	1,2
Protective Ground	Shield connection. Provides a path for the ground signal to an external single point ground.	Connector Shell	Connector Shell

Table 9-3: Digital Link Port Pin Assignments

Pin	Label	In/Out	Connector Pinout
IN Connector			<p>RJ-45 Connectors</p> <p>J10 DLINK IN</p> <p>“OUT” LINK LED</p> <p>“IN” LINK LED</p> <p>J9 DLINK OUT</p>
1	Receive +	In	
2	Receive -	In	
3	Transmit +	Out	
4	Not Used	N/A	
5	Not Used	N/A	
6	Transmit -	Out	
7	Not Used	N/A	
8	Not Used	N/A	
Connector Shield	Provides a path for the ground signal to an external single point ground.	In	
OUT Connector			
1	Transmit +	Out	
2	Transmit -	Out	
3	Receive +	In	
4	Not Used	N/A	
5	Not Used	N/A	
6	Receive -	In	
7	Not Used	N/A	
8	Not Used	N/A	
Connector Shield	Provides a path for the ground signal to an external single point ground.	In	

Table 9-4: Digital Link Port “IN” to “OUT” Cables

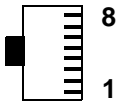
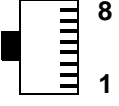
Table 9-4: Digital Link Port “IN” to “OUT” Cables				
Part Numbers: .3 M (1.0 ft): M.1302.8285 .6 M (2.0 ft): M.1302.8286 1 M (3.3 ft): M.1302.8287 2 M (6.6 ft): M.1302.8288 3 M (9.8 ft): M.1302.8289 5 M (16.4 ft): M.1302.8300 10 M (32.8 ft): M.1302.8301 15 M (49.2 ft): M.1302.8302 30 M (98.4 ft): M.1302.8303 Cable type: CAT-5 (or better), 28 AWG, shielded, twisted pair, 8 conductor.				
8-Pin RJ-45 Plug (to Digital Link Port “OUT”, face view) 		8-Pin RJ-45 Plug (to Digital Drive “IN”, face view) 		
Pin	Signal	Pin	Signal	Notes
1	Transmit Data +	1	Receive Data +	Twisted Pair
2	Transmit Data -	2	Receive Data -	
3	Receive Data +	3	Transmit Data +	Twisted Pair
6	Receive Data -	6	Transmit Data -	
4	None	4	None	Twisted Pair
5	None	5	None	
7	None	7	None	Twisted Pair
8	None	8	None	
Shell	Drain	Shell	Drain	

9.1.6 Auxiliary Feedback Port

The 15-pin female Auxiliary Feedback connector (labeled “J8 AUX FEEDBACK” on the front of the Drive) provides the interface between the S200-DLS Drive and a feedback device.

- Pin descriptions are provided in [Table 9-5](#)
- Pin assignments are provided in [Table 9-6](#)
- The available Flying Lead cable is described in [Table 9-7](#).
- Available Breakout Boxes and Cables are described in [Table 9-8](#).
- Breakout Box dimensions are shown in [Figure 9-3](#)
- Breakout Board dimensions are shown in [Table 9-4](#)

Table 9-5: Aux Feedback Port Pin Description

Aux Feedback Signals			
Signal Type	Signal Name	Notes	Pin
Incremental Encoder Inputs	A1, A1/, B1, B1/, I1, I1/	Differential A quad B encoder signals.	1, 2, 3, 4, 5, 10
BiSS Encoder Data Channel In/Out ^a	RS-485 Data +, RS-485 Data -, RS-485 Clock+, RS-485 Clock-	RS-485 signals for connecting a BiSS Encoder Data Channel to the drive	5, 10, 12, 13
Motor Commutation Hall Sensor Inputs	Commutation Track S1, S2, S3	Hall device input signals that are used to initialize the commutation angle. They consist of a 74HC14 input with 10 μ s filter and 1 K pull up to +5V. Shared with F2.	12, 13, 8
Temperature Input	Temperature	Thermostat (normally- closed) or Thermistor (Phillips KTY84-130 PTC or equivalent recommended) input for detecting over temperature conditions within the motor.	11
+5V Encoder Power Outputs	+5V Source	Regulated +5VDC for powering the attached encoder (250ma max).	14
Signal and Power Common	Common	Return path for feedback signals and +5V power supply.	6

a. In order to use a BiSS encoder with the S200-DLS drive, the drive must be Rev 3 or later (as found on the drive label), and the firmware within the drive must be Version 2.03 or later.

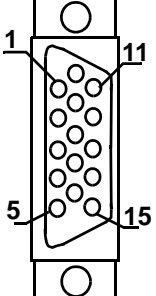
Table 9-6: Aux Feedback Port Pin Assignments				
Encoder Pin Assignments for Aux Feedback 15 Pin Connector				
Pin	Feedback Device		In/Out	Connector Pinout
	Digital Incremental Encoder	Endat ^a BiSS ^b SSI ^a		
1	A1	N/U	In	15-pin Female HD D-Sub 
2	A1/	N/U		
3	B1	N/U		
4	B1/	N/U		
5	I1	RS-485 Data+	Note ^c	
6	Common		In/Out	
7	N/U		N/A	
8	Commutation Track S3	N/U	In	
9	N/U		N/A	
10	I1/	RS-485 Data-	Note ^c	
11	Temperature		In	
12	Commutation Track S1	RS-485 Clock+	In ^d	
13	Commutation Track S2	RS-485 Clock-		
14	+5V Source		Out	
15	N/U		N/A	
Shell	Shield		N/A	

a. For future use

b. In order to use a BiSS encoder with the S200-DLS drive, the drive must be revision (as found on the drive label) Rev 3 or later (Rev 0 or later for 1.5A drive), and the firmware within the drive must be Version 2.00 or later

c. Pins 5 and 10 are In/Out for Endat, and Inputs for Digital Incremental, SSI, and BiSS

d. Pins 12 and 13 are Outputs for ENDAT, SSI, and BiSS

Table 9-7: Aux Feedback Port to Flying Lead Cable

Part Numbers: 1 M (3.3 ft): M.3000.0805 3 M (9.8 ft): M.3000.0806
 6 M (19.7 ft): M.3000.0807 9 M (19.5 ft): M.3000.0808
 Cable type: 28 AWG (pins 6 & 14 16 AWG), shielded, twisted pair, 16 conductor.

15-Pin HD male D-sub (to Aux Feedback Port, face view)

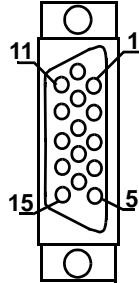

Pin	Signal	Color	Notes
1	A1	White	Twisted
2	A1/	White/Yellow	Pair
3	B1	Blue	Twisted
4	B1/	White/Blue	Pair
5	I1, RS-485 Data+	Black	Twisted
10	I1/, RS-485 Data-	White/Black	Pair
8	Commutation Track S3	Red	Twisted
	Not Connected	White/Red	Pair
14	+5V source	Gray	Twisted
6	Common	White/Gray	Pair
11	Temperature	Green	Twisted
	Not Connected	White/Green	Pair
12	Commutation Track S1, RS-485 Clock+	Violet	Twisted
13	Commutation Track S2, RS-485 Clock-	White/Violet	Pair
	Not Connected	Orange	Twisted
	Not Connected	White/Orange	Pair
7	Not Used	Brown	Twisted
	Not Connected	White/Brown	Pair
Shell	Drain	N/A	

Table 9-8: Aux Feedback Port Breakout Box and Cables		
Description	Length	Part Number
Aux Feedback Port Breakout Board ^a	N/A	M.1302.6970
Aux Feedback Port Breakout Box ^b	N/A	M.1302.6972
Aux Feedback Port to Breakout Box Cable	1 M (3.3 ft)	M.3000.0801
	3 M (9.8 ft)	M.3000.0802
	6 M (19.7 ft)	M.3000.0803
	9 M (29.7ft)	M.3000.0804

- a. The Breakout Board (see [Figure 9-3 on page 276](#)) is mounted directly to the Aux Feedback connector, and provides screw terminals wire termination.
- b. The Breakout Box (see [Figure 9-4 on page 276](#)) is DIN-rail mounted, and provides screw terminal wire termination. Use one of the cables listed in the table to connect between the Aux Feedback connector and the Breakout Box.

Figure 9-3: Aux Feedback Port Breakout Box Dimensions

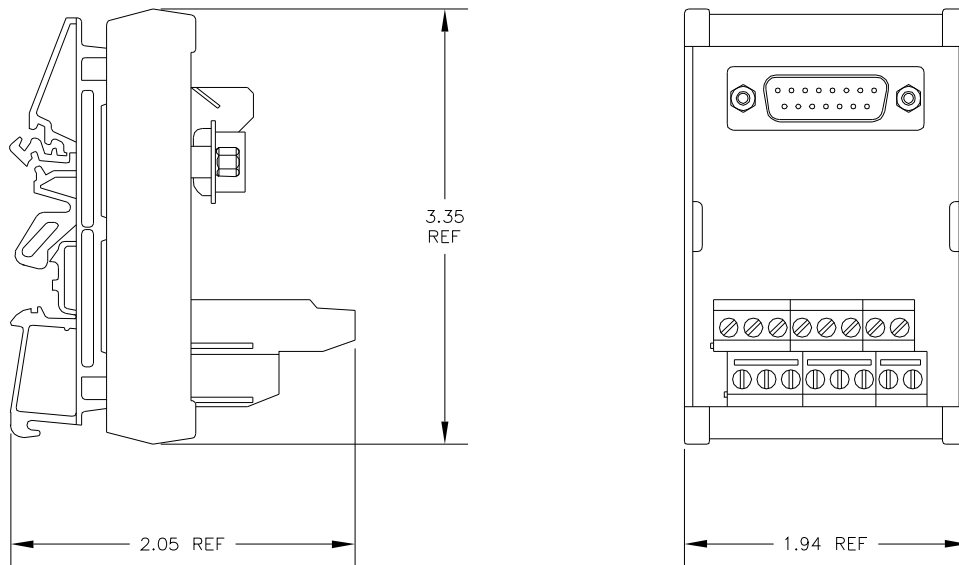

D15 SUB/P
PART NO. M.1302.6972

Figure 9-4: Aux Feedback Port Breakout Board Dimensions

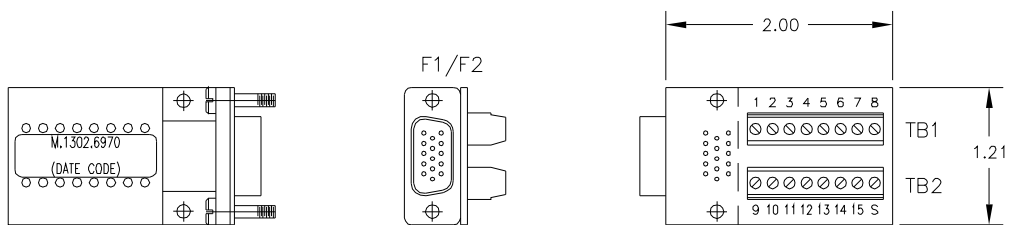

DANAHER MOTION PART NUMBER	DANAHER MOTION SHORT DESCRIPTION
M.1302.6970	BKOUT BD,F1/F2,MMC-SD DR MT

Table 9-9: Aux Feedback Port ENDAT/BiSS to AKM/DDR Motor Cable

Part Numbers:
 1 M (3.3 ft): M.1302.0809 3 M (9.8 ft): M.1302.0810 6 M (19.7 ft): M.1302.0811
 9 M (29.5 ft): M.1302.0812 15 M (49.2 ft): M.1302.0813 30 M (98.4 ft): M.1302.0814





Twisted Pair 7 pair 26 AWG 1 pair 16 AWG 1 pair 22 AWG	15-Pin HD male D-sub Connector to MMC Smart Drive		Connector to Motor		
					
Wire Color	Pin Number	Signal Type	Pin Number	Jumper Connections	Signal Type
Yellow	1	COS	9		B+
White/Yellow	2	COS/	1		B-
Blue	3	SIN	11		A+
White/Blue	4	SIN/	3		A-
Black	5	DATA+	5		DATA
White/Black	10	DATA-	13		DATA/
Violet	12	CLOCK+	8		CLOCK
White/Violet	13	CLOCK-	15		CLOCK/
Red	N/U	N/A	12		UnSENSE VCC
White/Red	N/U	N/A	10		UnSENSE COM
Green	11	TEMPERATUR	7		THERMAL
White/Green	N/U	N/A	14		THERMAL
Orange	N/U	N/A	N/U		N/A
White/Orange	N/U	N/A	N/U		N/A
Brown	7	9 VDC	N/U		N/A
White/Brown	N/U	N/A	N/U		N/A
Gray	14	+5 VDC	4		5VDC
White/Gray	6	COM	2	GND	
N/C	9	N/A	6	N/C	
N/C	15	N/A	16	N/C	
N/C	8	N/A	17	N/C	

Table 9-10: Aux Feedback Port Encoder to AKM/DDR Motor

Part Numbers:					
1 M (3.3 ft):	M.3000.1285	3 M (9.8 ft):	M.3000.1286	6 M (19.7 ft):	M.3000.1287
9 M (29.5 ft):	M.3000.1288	15 M (49.2 ft):	M.3000.1289	30 M (98.4 ft):	M.3000.1290
Twisted Pair 7 pair 26 AWG 1 pair 16 AWG 1 pair 22 AWG	D-sub 15-Pin HD Male Connector to MMC Smart Drive		Connector to Motor		
					
Wire Color	Pin Number	Signal Type	Pin Number	Jumper Connections	Signal Type
Yellow	1	A	3		A
White/Yellow	2	A/	4		A/
Blue	3	B	1		B
White/Blue	4	B/	2		B/
Black	5	I	5		I
White/Black	10	I/	6		I/
Violet	12	S1	15		S1
White/Violet	13	S2	16		S2
Red	8	S3	17		S3
White/Red	N/U	N/A	N/U		N/A
Green	11	TEMPERATURE	8		TEMPERATURE+
White/Green	N/U	N/A	9		TEMPERATURE-
Orange	N/U	N/A	N/U		N/A
White/Orange	N/U	N/A	N/U		N/A
Brown	7	9 VDC	11		N/A
White/Brown	N/U	N/A	N/U	N/A	
Gray	14	+5 VDC	10	+5 VDC	
White/Gray	6	COM	7	COM	
N/C	9	N/A	12	N/C	
N/C	15	N/A	13	N/C	
			14	N/C	

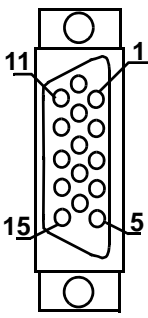
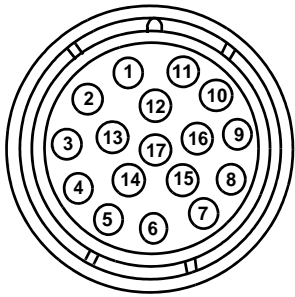
9.1.7 Drive I/O and I/O Power Ports

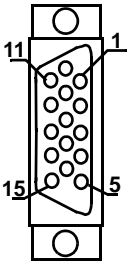
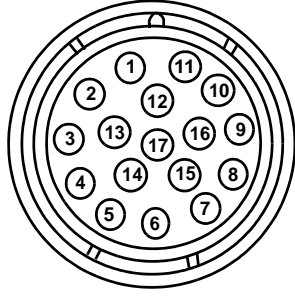
The 8-pin plugable spring-terminal Drive I/O Port connector (labeled “J7 DRIVE I/O” on the front of the Drive) in combination with the 6-pin plugable spring-terminal I/O Power Port connector (labeled “J6 I/O POWER” on the front of the Drive) provide connection between user I/O devices and the Drive. The Drive I/O port provides 4 source-only, 50ma, short-circuit and over-current protected outputs (described in detail in [section 9.1.8 on page 281](#)), and 4 sink or source (selectable in two groups of two) inputs (described in detail in [section 9.1.8 on page 281](#)). The I/O Power Port supplies power to the Drive I/O Port.

- Pin descriptions for the Drive I/O Port are provided in [Table 9-11](#), and for the I/O Power Port in [Table 9-12](#).
- Pin assignments for the Drive I/O Port are provided in [Table 9-13](#), and for the I/O Power Port in [Table 9-14](#).
- The available Drive I/O Port and I/O Power Port Accessories are described in [Table 9-15](#).
- The Drive I/O is discussed in more detail in [section 9.1.8 on page 281](#).

Table 9-11: Drive I/O Port Pin Descriptions

Function	Notes	Pin
DC Outputs 1-4	Nominal 24 Vdc Outputs capable of sourcing up to 50 ma.	5,6,7,8
DC Inputs 5-8	Nominal 24 Vdc sourcing/sinking Inputs	1,2,3,4

Table 9-12: Drive I/O Port Pin Assignments			
Pin	Signal	In/Out	Connector Pinout
1	DC Input 8	In	8-Pin plugable Screw Terminal Connector 
2	DC Input 7 (Data Capture input for J8 Aux Feedback connector)	In	
3	DC Input 6	In	
4	DC Input 5 (Data Capture input for J3 SFD Feedback connector)	In	
5	DC Output 4	Out	
6	DC Output 3	Out	
7	DC Output 2	Out	
8	DC Output 1	Out	

Table 9-13: I/O Power Port Pin Descriptions

Function	Notes	Pin
I/O 24V Power	Nominal 24 Vdc to power Drive I/O	3
I/O 24V Common	I/O 24V common	2
DC Inputs 5 and 6 Sink/source	This pin determines whether Drive I/O inputs 5 & 6 are sourcing (this pin connected to 24 Vdc Common) or sinking (this pin connected to 24 Vdc)	6
DC Inputs 7 and 8 Sink/source	This pin determines whether Drive I/O inputs 7 & 8 are sourcing (this pin connected to 24 Vdc Common) or sinking (this pin connected to 24 Vdc)	5
Chassis Ground	This pin should be connected to Chassis Ground	1

Table 9-14: I/O Power Port Pin Assignments

Pin	Signal	In/Out	Connector Pinout
1	Chassis Ground	In	6-Pin plugable Screw Terminal Connector 
2	Drive I/O 24 Vdc Common	In	
3	Drive I/O 24 Vdc	In	
4	N/C	N/A	
5	Input 7&8 Sink/Source	In	
6	Input 5&6 Sink/Source	In	

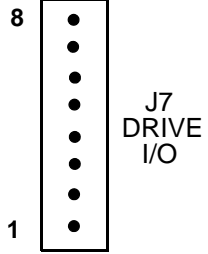
Table 9-15: Drive I/O and I/O Power Port Accessories

Description	Part Number
6-pin spring-contact pluggable mating connector for the I/O Power Port (J6)	M.1302.7662
8-pin spring-contact pluggable mating for connector for the Drive I/O Port (J7)	M.1302.7627
Kit containing one each of J6 and J7 connectors as described above	M.3000.0728
See section 9.2 on page 283 for Connector Kits that include connectors for the Power Section connectors (J1, J2, J3, and J4)	

9.1.8

Drive I/O Port Details

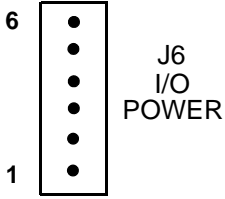
There are four DC Inputs and four DC Outputs available for interfacing to various devices. This section explains these Inputs/Outputs in detail.

9.1.8.1 Drive I/O Port Outputs

The Drive I/O Port provides 4 source-only 24 Vdc outputs. For sourcing outputs, one side of the load is connected to the Output pin on the Drive I/O connector, and the other side of the load is connected to 24 Vdc Common.

These outputs get their power from Pin 3 of the I/O Power connector. Each of the 4 outputs on the Drive I/O connector is a solid state switch rated at 50 ma, and is short-circuit and over-current protected. In addition, each output is protected with internal clamping diodes. Without clamping, high voltage transients (kickback) from inductive loads might damage the module. For safety reasons, all outputs turn off (no current flow) when a the user program (Ladder) is not running (Scan Loss), or communications to the Drive is lost.

9.1.8.2 Drive I/O Port Inputs

The Drive I/O Port also provides 4 sink/source 24 Vdc inputs.

To configure an Input as Sinking, the Sink/Source select pin (pin 6 for Inputs 5 and 6, pin 5 for inputs 7 and 8), must be connected to 24 Vdc. When configured as Sinking, one side of the input device is connected to the Input pin on the Drive I/O Port connector, and the other side of the input device must be connected to 24 Vdc Common.

To configure an Input as Sourcing, the Sink/Source select pin (pin 6 for Inputs 5 and 6, pin 5 for inputs 7 and 8), must be connected to 24 Vdc Common. When configured as Sourcing, one side of the input device is connected to the Input pin on the Drive I/O Port connector, and the other side of the input device must be connected to 24 Vdc.

9.1.8.3 Drive I/O Port Wiring Example

An example of wiring the Drive I/O is shown in [See Figure 9-5 on page 283](#).

- Since the Outputs are sourcing, one side of the output device is connected to the Output pin on the Drive I/O Port connector, and the other side is connected to 24 Vdc Common.
- The Sink/Source select pin for Inputs 5 and 6 on the I/O Power Port connector is connected to 24 Vdc, making Drive Inputs 5 and 6 Sinking. In this configuration, one side of the input device is connected to the Input pin on the Drive I/O Port connector, and the other side of the input device is connected to 24 Vdc Common.
- The Sink/Source select pin for inputs 7 and 8 on the I/O Power Port connector is connected to 24 Vdc Common, making Drive Inputs 7 and 8 Sourcing. In this configuration, one side of the input device is connected to the Input pin on the Drive I/O Port connector, and the other side of the input device is connected to 24 Vdc.

Figure 9-5: Connecting Devices to the Drive I/O Port

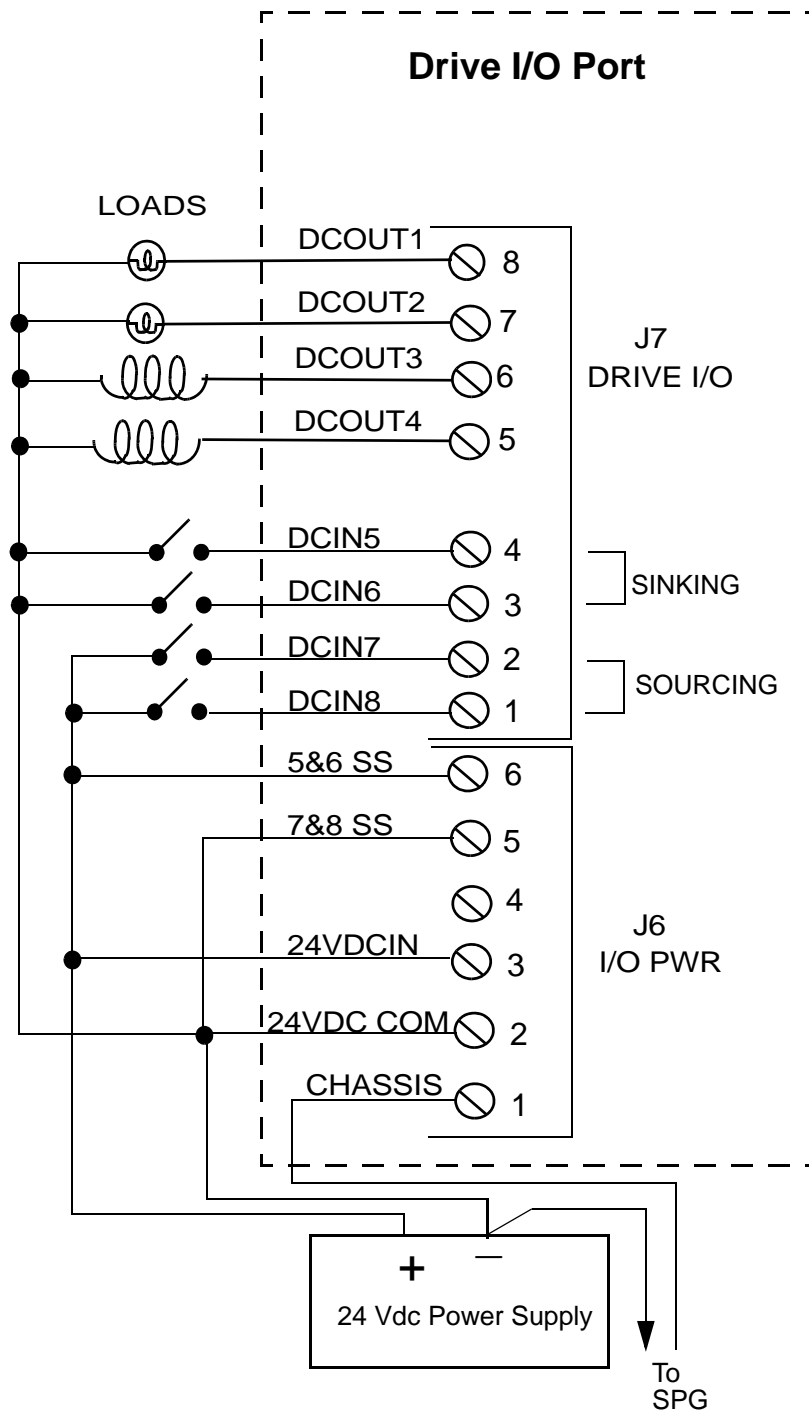

9.2 Power Section Wiring Accessories

This section describes wiring accessories related to the Power Section of the S200-DLS Drives.

Table 9-16: Power Section Wiring Accessories	
Description	Part Number
Command I/O (J4) Drive-mounted Breakout Board	M.1302.6971
Command I/O (J4) Panel-mounted Breakout Box	M.1302.6973
Command I/O (J4) to Breakout Box cables: 3.3ft (1M) 9.8ft (3M) 29.5ft (9M)	M.1302.6982 M.1302.6984 M.1302.6985
AC Power (J1, 1.5A, 3A, and 6A S200-DLS drives only) 9-pin screw terminal	767-009903-01
Ctrl Power (J1, 12A, 24A, and DC S200-DLS drives only) 3-pin screw terminal	767-003907-01
Motor Power (J2, 1.5A, 3A, 6A, and DC S200-DLS drives only ^a) 4-pin screw terminal	767-004908-01
Feedback (J3) 6-pin, solder terminal	749-139401-01
Kit containing one each of connector J1 (P/N 767-003907-01, as described above), plus J6 and J7 (as described in Table 9-15 on page 281)	M.3000.0727
Kit containing one each of connector J1 (P/N 767-009903-01, as described above), plus J6 and J7 (as described in Table 9-15 on page 281)	M.3000.0728

a. J2 is not present on the 12A and 24A S200-DLS drives. Connection for Motor Power is provided via a non-pluggable screw-terminal connector.

9.3 Specifications - S200-DLS Drive

The S200-DLS consists of a Base Unit with an S200 Digital Link Option Card installed. The combination of the two components is the S200-DLS Drive. The Base Unit is described in detail in Kollmorgen's S200 Base Unit Reference Manual, P/N M-SM-200-01, which can be found at http://www.kollmorgen.com/website/com/eng/products/drives/ac_servo_drives/s200_manuals.php. Please refer to the S200 Base Unit Reference Manual for Base Unit Specifications, Mounting information, Wiring information, etc. The Base Unit has the same Part Number as the Digital Link version, except that the -DLS is replaced with -VTS. For example, a S20360-DLS consists of an S20360-VTS Base Unit and an S200 Digital Link Option Card.

Any data contained in this manual takes precedence over conflicting data found in the Base Unit manual.

Part Numbers	
S20260-DLS	Input = 120/240VAC, Output = 1.5A RMS continuous
S20360-DLS	Input = 120/240VAC, Output = 3A RMS continuous
S20660-DLS	Input = 120/240VAC, Output = 6A RMS continuous
S21260-DLS	Input = 120/240VAC, Output = 12A RMS continuous
S22460-DLS	Input = 120/240VAC, Output = 24A RMS continuous
S20330-DLS	Input = 20-90VDC, Output = 3A RMS continuous
S20630-DLS	Input = 20-90VDC, Output = 6A RMS continuous
Drive I/O Port DC Inputs	
Configuration	<ul style="list-style-type: none"> • 4 optically isolated 24V DC inputs • Active high • Sink or source
Guaranteed On	15 VDC
Guaranteed Off	5 VDC
Time delay on	1 ms max.
Time delay off	1 ms max.
Input voltage	Nominal 24 VDC, maximum 30 VDC

Drive I/O Port DC Outputs	
Configuration	<ul style="list-style-type: none"> • 4 optically isolated 24V DC outputs • Active high • Current sourcing only (current into load) • Short circuit and overload protected
Maximum current	50mA per output
Voltage range	24VDC +15%-10%
Time delay on for resistive loads	50 µsec. max
Time delay off for resistive loads	50 µsec. max
Leakage current in off state	0.5 mA max
Digital Link In/Out Ports	
“In” port	Sends and receives high speed data to and from connected MMC-SD’s “Out” port.
“Out” port	Sends and receives high speed data to and from connected MMC-SD’s “In” port.
Cable Type	Shielded, Straight Pinned, CAT5 or better (CAT5e, CAT6, etc.)
Maximum Cable Length	30 m (98.4 ft)
Conformity	
CE Marked Note: Only units Rev 1 or higher are CE Marked.	Conforms to Low Voltage Directive 73/23/EEC (amended by 93/68/EEC) and EMC Directive 89/336/EEC (amended by 92/31/EEC and 93/68/EEC). Conformance is in accordance with the following standards: EN 50178 and EN61800-3
UL and C/UL Recognized	E233454
RoHs	The S200-DLS Drives are not RoHs compliant

10 Motor Cables & Connectors

Kollmorgen offers many cables that connect directly from the MMC Smart Drive's F1/F2 connector to various Kollmorgen motors. These cables are described in detail in [section 7.1.6.2 on page 182](#).

This section describes additional cables and connector kits that can be used to connect Kollmorgen motors and drives, as well as providing cable installation guidelines.

10.1 Flex Cable Installation Guidelines

Follow these guidelines for any flexing cable application:

- Cable should be hung suspended for 48 hours to develop its most natural “set* and lay” prior to installation
- A cable should be installed with, not against, its natural set
- Using strain relief fittings at both ends of the cable will reduce conductor breakage at the flex points
- If there is any kink in a cable after installation, it will always remain and eventually cause a cable failure
- After installation, the most critical factors in the cable are the minimum bend radius and the reel tension

* Note: The natural set occurs during the manufacturing of the cable. The cable is cured in one direction on the reel with a notable difference in its ability to be flexed one way versus the other.

When using specially designed flex cables, the following five criteria must be considered:

- Bending Radius
- Cable Tension
- Operating Speed
- Temperature
- Ampacity

Bending Radius and Cable Tension are discussed in the following sections.

10.1.1 Bending Radius

The following guidelines recommended by the ICEA standards are intended to optimize cable life:

- Minimum Bend Radius (Shielded Feedback Cables) = 12 times the Cable Diameter
- Minimum Bend Radius (Shielded Power Cables) = 12 times the Cable Diameter

Reduced bending radii result in reduced cable life due to increased stress on the copper conductors and overall distortion of the cable. Therefore, reduced radii should only be considered for applications in which other factors, such as reduced cable tension, lower operating speed, and ambient temperature are more favorable to cable life, or where the mechanical limitations of the installation do not allow the optimum radius.

Doubling the minimum bending radius for reeling applications can triple cable life at the maximum recommended tension. Therefore, the largest possible bending radius should be used to increase cable life.

10.1.2 Cable Tension

Cable tension plays an extremely important role in determining cable life in reeling. The copper conductors are the principle strength member in flexible cable constructions. Even if strain relief fittings are used on the cable ends, most of the tension will still be supported by the copper conductors.

The effects of tension on a cable are dependent upon the pounds per cross-sectional area of the copper conductors. Larger AWG wires and/or more conductors can handle more tension than smaller AWG wires and/or fewer conductors.

10.2 Flex Cable Installation

Cables should be fixed on both ends to relieve them of tensile loads and prevent any loads from being applied to the molded connectors. At a minimum, the cables have to be fixed on the moving end of the track. A distance of 3 to 6 inches from the track to the fixation point is recommended (See [Figure 10-1](#)).

WARNING: CABLE DAMAGE
Failure to properly isolate Flex, Pull, and Torsional forces from the connector ends will result in electrical and mechanical breakdown. Over clamping at the fixation point can result in cable damage.

Figure 10-1: Flex Cable Installation

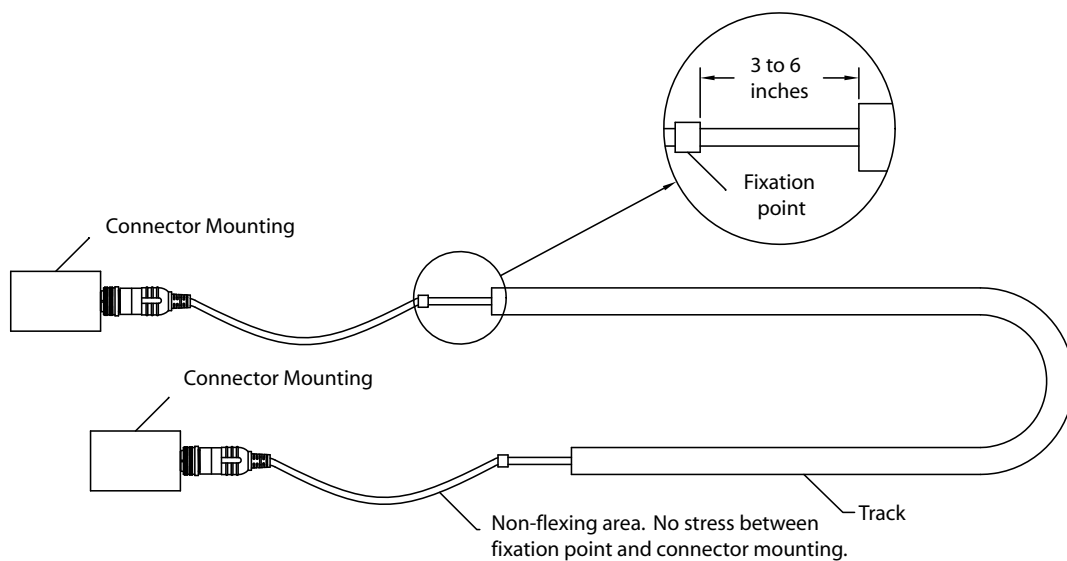

Observe the following precautions when installing flex cables:

- The cable must be able to move freely in the track
- The cable must be able to move in the radius section of the track. This must be checked in the track's fully extended position.
- When cables of different diameters are installed, the use of vertical separators or horizontal shelving is recommended. Cables of similar diameters can be put in the same compartment.
- Cables should never be put on top of one another in high velocity or high cycle applications.
- The cable's weight should be distributed symmetrically over the chain width.

10.3 AKM/DDR Motor Power Cables

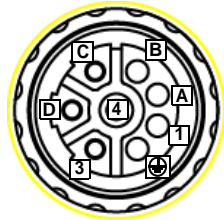

This section describes flying-lead wiring assemblies that can be used connect the Motor power signals from the drive to an AKM/DDR motor. Each assembly consists of the proper motor connector, and the indicated length and gauge of Hi-Flex cable.

Table 10-1: AKM/DDR Motor Power Cables			
For Connection Diagram, Table 10-2 on page 290			
Length	Part Number		
	12AWG	14AWG	16AWG
1 M (3.3 ft)	M.1302.8759	M.1302.8585	M.1302.8580
3 M (9.8 ft)	M.1302.8760	M.1302.8549	M.1302.8545
6 M (19.7 ft)	M.1302.8761	M.1302.8586	M.1302.8581
9 M (29.5 ft)	M.1302.8762	M.1302.8554	M.1302.8553
15 M (49.2 ft)	M.1302.8763	M.1302.8588	M.1302.8583
30 M (98.4 ft)	M.1302.8764	M.1302.8589	M.1302.8584

Table 10-2: AKM/DDR Motor Power Cable Connections			
			Connector Pinout 
Wire Color	Wire Number	Signal Type	Size 1 Power Connector
Black (1)	U	Out	1
Black (2)	V	Out	4
Black (3)	W	Out	3
Green/ Yellow	PE	Ground	2
Black (5)	Brake+	Out	A
White (6)	Brake-	Out	B

10.4 LSM/MSM Motor Connector Kits

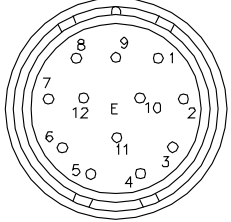
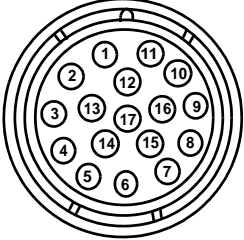
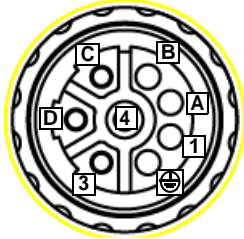
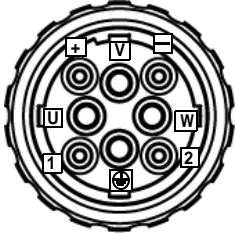
This section describes LSM/MSM Motor mating connectors for use in constructing custom cables using user-supplied cable. Available connectors are described in [Table 10-3](#).

Table 10-3: Connector Kits for LSM/MSM Motors			
Function	Wire Size	Part Number	Figure
Feedback	18-28AWG	M.1302.0500	
Feedback	18-28AWG	M.1302.0510	
Power/Brake	14-16AWG	M.1302.0479	
Power/Brake	12AWG	M.1302.8755	
Power/Brake	12-14AWG	M.1302.1998	
Power/Brake	8-10AWG	M.1302.2354	
Power/Brake	6AWG	M.1302.7492	Consult Factory
Power/Brake	4AWG	M.1302.7493	
Fan	16AWG	M.1302.6219	

10.5 LSM/MSM Motor Power Cables



This section describes flying-lead wiring assemblies that can be used connect the Motor Power signals from the drive to an LSM/MSM motor. Each assembly consists of the indicated length and gauge of Hi-Flex cable pre-wired to the indicated LSM/MSM Motor power connector.

Table 10-4: LSM/MSM Motor Power Flying-lead Cables			
Wire Gauge	Figure	Wire Length	Hi-Flex P/N
16AWG	Size 1 in Table 10-5 on page 294	1 M (3.3 ft)	M.1302.1114
		3 M (9.8 ft)	M.1302.1115
		6 M (19.7 ft)	M.1302.1116
		9 M (29.5 ft)	M.1302.1117
		15 M (49.2 ft)	M.1302.1118
14AWG	Size 1 in Table 10-5 on page 294	1 M (3.3 ft)	M.1302.1119
		3 M (9.8 ft)	M.1302.1130
		6 M (19.7 ft)	M.1302.1131
		9 M (29.5 ft)	M.1302.1132
		15 M (49.2 ft)	M.1302.1133
12AWG	Size 1.5.1 in Table 10-5 on page 294	1 M (3.3 ft)	M.1302.1134
		3 M (9.8 ft)	M.1302.1135
		6 M (19.7 ft)	M.1302.1136
		9 M (29.5 ft)	M.1302.1137
		15 M (49.2 ft)	M.1302.1139
10AWG	Size 1.5.1 in Table 10-5 on page 294	1 M (3.3 ft)	M.1302.1140
		3 M (9.8 ft)	M.1302.1142
		6 M (19.7 ft)	M.1302.1143
		9 M (29.5 ft)	M.1302.1144
		15 M (49.2 ft)	M.1302.1145

8AWG	Size 1.5.2 in Table 10-5 on page 294	1 M (3.3 ft)	M.1302.1146
		3 M (9.8 ft)	M.1302.1147
		6 M (19.7 ft)	M.1302.1148
		9 M (29.5 ft)	M.1302.1149
		15 M (49.2 ft)	M.1302.1150
6AWG	Consult Factory	1 M (3.3 ft)	CF ^a
		3 M (9.8 ft)	CF
		6 M (19.7 ft)	CF
		9 M (29.5 ft)	CF
		15 M (49.2 ft)	CF
4AWG	Consult Factory	1 M (3.3 ft)	CF
		3 M (9.8 ft)	CF
		6 M (19.7 ft)	CF
		9 M (29.5 ft)	CF
		15 M (49.2 ft)	CF
2AWG	Consult Factory	1 M (3.3 ft)	CF
		3 M (9.8 ft)	CF
		6 M (19.7 ft)	CF
		9 M (29.5 ft)	CF
		15 M (49.2 ft)	CF

a. Consult Factory

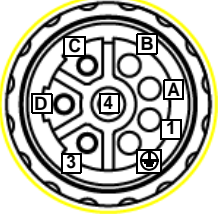
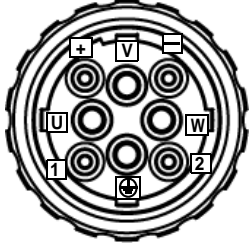
Table 10-5: LSM/MSM Motor Power Connector Flying Lead Cables

			Connector Pinout		
					
Wire Color	Wire Number	Signal Type	Size 1 Power Connector	Size 1.5.1 Power Connector	Size 1.5.2 Power Connector
Black (1)	1U2	Out	1	U	U
Black (2)	1V2	Out	3	V	V
Black (3)	1W2	Out	4	W	W
Green/ Yellow	PE	Ground	2		
Black (5)	Brake+	Out	A	+	+
Black (6)	Brake-	Out	B	-	-

10.6 LSM/MSM Motor Fan Cables

This section describes flying-lead wiring assemblies that can be used connect the Motor Fan signals from the drive to an LSM/MSM motor. Each assembly consists of the indicated length of 16AWG cable pre-wired to the LSM/MSM Motor fan connector. The wiring Diagram for these cables can be found in [Table 10-7](#).

Cable Length	Part Number
1 M (3.3 ft)	M.1302.6310
3 M (9.8 ft)	M.1302.6311
6 M (19.7 ft)	M.1302.6312
9 M (29.5 ft)	M.1302.6313
15 M (49.2 ft)	M.1302.6314

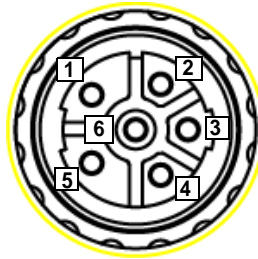
			Connector Pinout
			
Wire Color	Wire Number	Signal Type	Pin
Brown	U	Out	1
Black	N	Out	2
Green/Yellow	PE	Ground	3

11 Maintenance and Troubleshooting

11.1 Maintenance

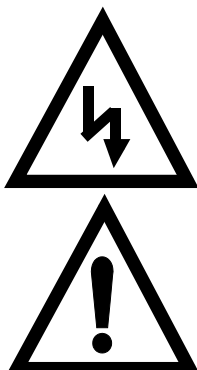
WARNING	
	<p>Disconnect input power before touching cables or connections.</p> <p>DC bus capacitors may retain hazardous voltages after input power has been removed.</p> <p>Before working on the drive, measure the DC bus voltage to verify it has reached a safe level.</p> <p>Failure to observe this precaution could result in severe bodily injury or loss of life.</p>

- Remove superficial dust and dirt from the drive.
- Check cable insulation and connections.
- Clean exterior surfaces and airflow vents using an OSHA approved nozzle that provides compressed air under low pressure of less than 20 kPa (30 psi).
- Visually check for cable damage. Replace all damaged cables.
- Inspect D-shell connectors for proper seating and signal continuity end-to-end.

11.2 Troubleshooting

11.2.1 General Troubleshooting

Refer to [Table 11-1](#) for general troubleshooting information.

Symptom	Possible Cause	Remedy
Power (P) indicator not ON	No 24VDC input power.	Verify 24 VDC power is applied to the drive.
	Internal power supply malfunction.	Contact your Kollmorgen representative.
Motor jumps when first enabled	Motor wiring error.	Check motor feedback and power wiring.
	Incorrect motor chosen.	Verify the proper motor is selected.
	Incorrect or faulty encoder	Replace the encoder with correct and/or functional encoder.
I/O not working correctly	I/O power supply disconnected.	Verify connections and I/O power source.

11.2.2 Power LED

The 230V and 460V Smart Drives contain a Power LED (P). If the Power LED does not go on when 24 VDC power is applied to the drive, or goes off during operation of the drive, check that 24 VDC power is still present at the 24 VDC Power Connector.

The S200-DLS and the Smart Drive NextGen do not have Power LEDs.

11.2.3 Power-On Diagnostics

- The 230V Smart Drive, the 460V smart Drive, and the S200-DLS contain a Diagnostic LED (D1). When power is first applied to the drive, power-up diagnostics are performed, and this LED is illuminated. When the diagnostics are successfully completed, the Status LED is turned off.
- The 460V Smart Drive NextGen contains a 2-digit 7-segment display. When power is first applied to the drive, power-up diagnostics are performed, and “F” is displayed on the left, and three horizontal lines are displayed on the right. When the diagnostics are successfully completed, the display changes to “00”.

11.2.4 Run-Time Diagnostics

While the Drive is running, other tests are performed on a regular basis with their results reported through various indicators, depending on the drive type.

- The 230V smart Drive, 460V Smart Drive, and S200-DLS contain a Diagnostic LED (D1) that is located on the front of the Drive. This Diagnostic LED is covered in detail in [section 11.2.4.1 on page 299](#).
- The 460V Smart Drive NextGen contains a 2-digit 7-segment display that is located on the front of the Drive. This display is covered in detail in [section 11.2.4.2 on page 299](#).
- The S200-DLS contains an additional Status LED (labeled “STATUS”), that is located on the front of the Drive. This Status LED is covered in detail in [section 11.2.4.3 on page 307](#).

11.2.4.1 Troubleshooting with the Diagnostic LED (D1)

This section pertains to the Diagnostic LED labeled “D1” located on the front of the 230V Smart Drive, the 460V Smart Drive, and the S200-DLS Drive. The S200-DLS Drive also has a Status LED, labeled “STATUS”, which is covered in [section 11.2.4.3 on page 307](#).

When a Warning or Fault is detected, the Diagnostic LED (D1) located on the face of the drive will flash a one-digit Warning Code or a two-digit Fault Code. The LED will continue to flash the Code until the Warning or Fault is eliminated.

For example, if there is a long pause-flash-pause-flash-flash-long pause, the Code is 12.

Warning conditions give the user an indication of a potential problem, but do not disable the drive. Whenever a Warning condition is detected, the drive generates a single-digit Warning Code. The user can detect a Warning condition in three ways:

- by visually observing the "D1" LED on the front of the Drive
- by examining the Drive Maintenance page in PiCPro under “Faults and Warnings”
- by reading the Warning Code using READ_SV variable 69 from within the user’s Ladder.

Fault conditions give the user an indication of a more serious problem, and disable the Drive. Whenever a Fault condition is detected, the drive generates a two-digit Fault Code.

The Drive Diagnostic Codes are described in [Table 11-2](#).

11.2.4.2 Troubleshooting with the 7-Segment Display

This section pertains to the 7-segment display located on the front of the 460V Smart Drive NextGen.

When a Warning or Fault is detected, the Display located on the face of the drive will indicate a one-digit Warning Code or a two-digit Fault Code. The code will remain on the Display until the Warning or Fault is eliminated.

Warning conditions give the user an indication of a potential problem, but do not disable the drive. Whenever a Warning condition is detected, the drive generates a single-digit Warning Code. The user can detect a Warning condition in three ways:

- by visually observing the Display on the front of the Drive
- by examining the Drive Maintenance page in PiCPro under “Faults and Warnings”
- by reading the Warning Code using READ_SV variable 69 from within the user’s Ladder.

Fault conditions give the user an indication of a more serious problem, and disable the Drive. Whenever a Fault condition is detected, the drive generates a two-digit Fault Code.

The Drive Diagnostic Codes are described in [Table 11-2](#).

Table 11-2: Drive Diagnostic LED Codes			
Code	Description	Possible Causes	Possible Remedies
Codes 01 through 06 are Warning Codes, and do not disable the Drive			
01	Drive Heatsink Temp. Warning	Drive heatsink temperature exceeds warning limit	<ul style="list-style-type: none"> • Lower the ambient temperature around the drive.
02	Drive Ambient Temp. Warning	Acceptable ambient temperature limit has been exceeded warning limit	
03	Motor Temp. Warning (available only when the motor contains a thermistor)	Thermistor temperature has exceeded user defined acceptable limit.	<ul style="list-style-type: none"> • Reduce acceleration rates. • Reduce duty cycle (ON/OFF) of commanded motion. • Increase time permitted for motion. • Use larger drive and motor. • Check tuning.
04	Motor Calculated Temp. Warning (available only when the motor does not contain a thermistor).	Calculated motor temperature has exceeded acceptable limit	
05	Overtravel Plus Warning	The Overtravel Plus Fault input is low because the axis has reached the Plus Travel Limit.	Move the axis off the Plus Limit Switch in the negative direction.
06	Overtravel Minus Warning	The Overtravel Minus Fault input is low because the axis has reached the Minus Travel Limit.	Move the axis off the Minus Limit Switch in the positive direction.
Codes 11 and higher are Fault Codes, and disable the Drive			
11	Drive Memory Fault	The drive's non-volatile memory is not functioning properly	Upgrade firmware. Contact Kollmorgen.

Table 11-2: Drive Diagnostic LED Codes (Continued)			
Code	Description	Possible Causes	Possible Remedies
12	Drive Bus Over Voltage Fault	Excessive regeneration of power. The motor may regenerate too much peak energy through the drive's power supply. A fault is generated to prevent overload.	Change the deceleration or motion profile. Check shunt connections and where necessary, properly make connections. Reduce the reflected inertia of your mechanical system. Use a larger motor and/or drive.
		Excessive AC input voltage.	Verify input AC voltage is within specifications. Adjust accordingly.
		Output short circuit.	Remove all power and motor connections, and perform a continuity check from the DC bus to the U, V, and W motor outputs. If a continuity exists, check for wire fibers between terminals, contact Kollmorgen
		Motor cabling wires shorted together.	Disconnect motor power cables from the drive. Test the cables for short circuits. Replace cable if necessary.
		Internal motor winding short circuit.	Disconnect motor power cables from the motor. If the motor is difficult to turn by hand, it may need to be replaced. Test winding resistance to confirm short circuit.
		230V motor used with a 460V drive and drive powered at 460V.	Set the drive for operation at 230V and apply 230V power to the drive.
13	Drive PM1 Over Current Fault	Current feedback exceeds the drive over current fault limit.	Adjust the over current fault limit.
		Output short circuit.	Remove all power and motor connections, and perform a continuity check from the DC bus to the U, V, and W motor outputs. If a short exists, check for wire fibers between terminals, contact Kollmorgen
		Motor cabling wires shorted together.	Disconnect motor power cables from the drive. If faults stop, replace cable.
		Internal motor winding short circuit.	Disconnect motor power cables from the motor. If the motor is difficult to turn by hand, it may need to be replaced.

Table 11-2: Drive Diagnostic LED Codes (Continued)

Code	Description	Possible Causes	Possible Remedies
14	Drive Over Power Fault	Drive current and voltage output, in combination with the heatsink temperature indicate that the power output required by the drive would damage the power section.	Verify ambient temperature is not too high. Operate within the continuous power rating. Reduce acceleration rates. Check for mechanical load problems and adjust as necessary. Resize the application and apply components accordingly.
15	Motor Temperature Fault	Motor thermostat trips due to high motor ambient temperature	Operate within (not above) the continuous torque rating for the ambient temperature (40°C maximum). Lower ambient temperature, increase motor cooling. Check that motor is properly sized for the application. If necessary, resize the motor.
		Motor thermostat trips due to excessive current	Reduce acceleration rates. Increase time permitted for motion. Use larger drive and motor. Reduce duty cycle (ON/OFF) of commanded motion. Check tuning.
		Motor thermostat trips due to motor wiring error.	Check motor wiring.
		Motor thermostat trips due to incorrect motor selection.	Verify the proper motor has been selected.
16	Continuous Current Fault	Current exceeds the continuous motor current rating for an extended period of time.	Change motor and or drive to be compatible with load requirements. Check tuning.
17	Drive Heatsink Temperature Fault	Drive heatsink temperature exceeds drive heatsink fault limit	Let the drive cool down and/or reduce the load.
22	Drive F1 Feedback Fault	Error is detected in the motor feedback	Verify motor selection is correct. Check to be sure the correct encoder is attached. Verify encoder wiring is correct. Use shielded cables with twisted pair wires. Route the encoder feedback cable away from potential noise sources. Check ground connections.

Table 11-2: Drive Diagnostic LED Codes (Continued)			
Code	Description	Possible Causes	Possible Remedies
23	Drive Ambient Temp. Fault	Drive ambient temperature exceeds the drive ambient temperature fault limit	Operate within (not above) the continuous rating for the ambient temperature. Lower ambient temperature, increase cabinet cooling.
24	Motor Calculated Temp. Fault	Motor calculated temperature exceeds the motor calculated temperature fault limit.	Check the machine for excessive loads. Motor may be undersized for the application.
25	Drive Timing Fault	Timing error is detected in the execution of the control algorithms performed by the drive's digital signal processor.	Contact Kollmorgen.
26	Drive Interface Fault	Communication error is detected in the transmission of information between the drive's digital signal processor and the drive's power section.	Contact Kollmorgen.
27	User Set Fault	PiCPro Set User Fault command selected.	The PiCPro Set User Fault command was selected or the Control Panel mode was activated or deactivated while the drive was enabled.
31	Drive F1 Communication Fault	Communication error is detected in the transmission of information between the drive and a high resolution or multi-turn absolute feedback device.	Check encoder line and make sure the correct encoder is attached. Verify encoder wiring is correct. Use shielded cables with twisted pair wires. Route the encoder feedback cable away from potential noise sources. Check ground connections. Verify motor selection is correct.
		Bad encoder.	Replace motor and encoder.
32	Over Speed Fault	User specified motor speed has been exceeded.	Check cables for noise. Check tuning.
33	Over Current Fault	User-Specified average current level has been exceeded.	Change to a less restrictive setting. Reduce the load.
34	Drive Communication Fault	Communication error occurs while drive control is being performed using the PiCPro Control Panel tools.	Do not disconnect the PiCPro cable while operating in Control Panel Mode.

Table 11-2: Drive Diagnostic LED Codes (Continued)			
Code	Description	Possible Causes	Possible Remedies
35	Drive Power Module Fault	The drive's power section detects a fault condition.	Verify AC power is applied to drive. Contact Kollmorgen.
36	Drive Setup Data Fault	The configuration data has been corrupted.	Re-download Drive Setup Data.
37	Endat/BiSS Fault	Endat/BiSS encoder did not respond to serial message Endat/BiSS encoder CRC error Endat/BiSS encoder counts/rev does not match the entered value Hardware does not match the selected device	Use DRSETFLT to reset fault indications Make sure all cable connections are secure and properly grounded
41	Drive Relay Fault	The drive's power section relay did not function properly during power-up.	Check the drive system connections. Adjust as necessary. Contact Kollmorgen.
42	Drive PM2 Over Current Fault	Current feedback exceeds the drive over current fault limit.	Adjust the over current fault limit.
		Output short circuit.	Remove all power and motor connections, and perform a continuity check from the DC bus to the U, V, and W motor outputs. If a continuity exists, check for wire fibers between terminals, contact Kollmorgen.
		Motor cabling wires shorted together.	Disconnect motor power cables from the drive. If faults stop, replace cable.
		Internal motor winding short circuit.	Disconnect motor power cables from the motor. If the motor is difficult to turn by hand, it may need to be replaced.
43	Drive PM Over Temperature Fault	Drive power module temperature exceeds the drive power module temperature fault limit	Check to be sure that the drive is being operated within the continuous power rating. Check for adequate enclosure ventilation. Ensure cooling air flow is adequate in space around the drive. Check for clogged vents or defective fan. Contact Kollmorgen.

Table 11-2: Drive Diagnostic LED Codes (Continued)			
Code	Description	Possible Causes	Possible Remedies
44	Motor Ground Fault	Ground fault has occurred.	Make sure motor ground connections are correct. Replace defective motor ground wires. Check for internal motor winding short circuits.
45	Drive AC Input Over Voltage Fault	Incoming AC voltage is too high.	Verify input VAC is within specifications.
46	Overtravel Plus Fault	Overtravel Plus Fault input is off and Drive Ignore Plus Travel Limit is off.	Overtravel Plus Fault status can be monitored using READ_SV variable 68 AND (16#400 0000). Fault input write a 0 to WRITE_SV variable 86. Use DRSETFLT to reset fault indications. To override the Overtravel Plus Fault input write a 1 to WRITE_SV variable 86, Ignore Plus Travel Limit. To reactivate checking of the Overtravel Plus input write a 1 to WRITE_SV variable 86, Ignore Plus Travel Limit. To reactivate checking of the Overtravel Plus Fault input write a 0 to WRITE_SV variable 86.
47	Overtravel Minus Fault	This fault is set when the Overtravel Minus Fault input is off and Drive Ignore Minus Travel Limit is off.	Overtravel Minus Fault status can be monitored using READ_SV variable 68 AND (16#800 0000). Use DRSETFLT to reset fault indications. To override the Overtravel Minus Fault input write a 1 to WRITE_SV variable 87, Ignore Minus Travel Limit. To reactivate checking of the Overtravel Minus Fault input write a 0 to WRITE_SV variable 87.
51	Digital Link Communication Error	This fault is set when two consecutive corrupt Digital Link messages are detected or no Digital Link messages are received within 250 microseconds.	Digital Link Communication Error status can be monitored using READ_SV variable 68 AND (16#1000 0000). This fault requires that the user servo setup function and DSTRTSRV be executed prior to executing DRSETFLT to reset the fault indication.
52	Invalid Switch Setting Fault	This fault is set when the drive address switch setting is set to 0 or greater than 64 or its setting is changed while the Digital Link is operating in cyclic communications mode.	Invalid Switch Setting Fault status can be monitored using READ_SV variable 68 AND (16#2000 0000). Use DRSETFLT to reset fault indications. Note: Digital Link initialization must be performed before this fault can be reset.

Code	Description	Possible Causes	Possible Remedies
53	Cannot Determine Drive Type	<ul style="list-style-type: none"> Regulator board was initialized when installed on a different Power Board. Flash Data Invalid or Not Readable, 	<ul style="list-style-type: none"> Re-initialize Drive Drive damaged - consult factory
77	Drive Not Ready	Power applied to an uninitialized drive.	Initialize and configure the drive using PiCPro.

11.2.4.3 Troubleshooting using the Status LED (STATUS)

This section pertains to the Status LED labeled “STATUS” located on the front of the S200-DLS Drive. The 230V Smart Drive, the 460V Smart Drive, and the S200-DLS Drive also have a Diagnostic LED, labeled “D1”, which is covered in [section 11.2.4.1 on page 299](#).

Fault codes for the S200-DLS Drive are described in [Table 11-3](#).

Fault Code	Fault	Possible Causes
ON	No faults and power stage Enabled	Normal Operation
OFF	control power not applied insufficient control power applied	Loose or open circuit wiring of control power input. Low input voltage to control power supply.
Fast Blink	No faults and power stage Disabled	Hardware or Software Enable inactive. To enable the Drive, apply hardware enable and set software enable.
2	Motor Over Temp <ul style="list-style-type: none"> motor temperature exceeds allowed limit 	High ambient temperature at motor. Insufficient motor heat sinking from motor mounting. Operating above the motor’s continuous current rating. Motor temperature sensor failure or not connected.
3	Drive Over/Under Temp <ul style="list-style-type: none"> Temperature of drive heatsink/chassis is outside of allowed limits 	<ul style="list-style-type: none"> High or low drive ambient temperature. Restriction of cooling air due to insufficient space around unit. Operating above the drive’s continuous current rating.

Table 11-3: Drive Status LED Fault Codes (Continued)		
Fault Code	Fault	Possible Causes
4	<p>Drive I*t Too High</p> <ul style="list-style-type: none"> • The product of the drives output current multiplied by time has exceeded allowed limits. • If current foldback is enabled the drive peak output current automatically reduces to 0.67% of DIpeak. If foldback is not enabled, the drive will fault. 	<ul style="list-style-type: none"> • Mechanically-jammed motor. • Motion profile acceleration requires peak current for too long of a time duration. • Machine load on the motor increased by friction. • Wiring problem between drive and motor yielding improper motion.Motor commutation error. • Drive under-sized for application, friction or load.
5	<p>Motor I*I*t Too High</p> <ul style="list-style-type: none"> • Motor current amplitude squared multiplied by time has exceed allowed limits 	<ul style="list-style-type: none"> • Mechanically-jammed motor. • Motion profile acceleration requires peak current for too long of a time duration. • Machine load on the motor increased by friction. • Motor commutation error. • Motor under-sized for application, friction or load.
6	<p>Optional Battery low</p> <ul style="list-style-type: none"> • Optional fault used to indicate SFD battery supply voltage is low 	<ul style="list-style-type: none"> • Battery low fault enabled and battery is not installed. • SFD Battery backup voltage is low.
7	<p>Bus Over Voltage - Self Re-setting</p> <ul style="list-style-type: none"> • The BUS voltage has exceed the upper threshold limit 	<ul style="list-style-type: none"> • AC Line voltage is too high. • Regenerative energy during deceleration is causing the BUS to rise (possible remedy: add regen resistor).
9	<p>Motor I-I or I-n Short</p> <ul style="list-style-type: none"> • Line-to-Line, Line-to-Neutral or Line-to-PE short on the motor output causing an instantaneous over current. 	<ul style="list-style-type: none"> • Motor power wiring short circuit - line-to-ground /neutral. • Motor cable short line-to-line. • Motor power cable length exceeds the data sheet specification causing excessive motor line-to-earth ground/ neutral capacitance. • Internal motor winding short circuit. • Motor L too small. • KIP set too large.

Table 11-3: Drive Status LED Fault Codes (Continued)

Fault Code	Fault	Possible Causes
10	Output Over Current	<ul style="list-style-type: none"> • Insufficient motor inductance • KIP or KII improperly set causing excessive output current overshoots.
11	Hall Fault <ul style="list-style-type: none"> • Valid only when drive is set for 6 Step (Hall feedback) operation. 	<ul style="list-style-type: none"> • Invalid configuration. • Motor overspeed. • Invalid hall state. • Invalid hall transition.
12	SFD Configuration Error	<ul style="list-style-type: none"> • SFD UART error during SFD initialization. • Bad motor data check sum. • The drive will attempt to initialize the SFD up to 4 times. If it fails this error is reported.
13	J3 FB +5V Short <ul style="list-style-type: none"> • Excessive current drain on SFD +5 supply output. 	<ul style="list-style-type: none"> • Excessive loading on SFD +5 supply. • Short in the feedback cable on SFD +5 (J3-1) to ground.
14	SFD Motor Data Error <ul style="list-style-type: none"> • Motor data in SFD is outside drive limits or is inconsistent 	<ul style="list-style-type: none"> • Motor and Drive are not compatible. Auto setup calculation yielded a desired parameter value outside valid range. • Incorrect/inconsistent motor data loaded into the SFD.
15	SFD Sensor Failure Internal SFD failure.	Excessive electrical noise in the drive environment causing communications interference.
16	SFD UART Error	Internal SFD failure.
17	SFD Communication Error	<ul style="list-style-type: none"> • Feedback cable not connected at the drive or at the motor. • Feedback cable shield not connected. • Defective feedback cable • Internal SFD failure. • Excessive electrical noise in the drive environment causing communications interference.
18	Option Card Watch Dog Time out	Communication error between option card and main board.

Table 11-3: Drive Status LED Fault Codes (Continued)		
Fault Code	Fault	Possible Causes
19	Position Error Too Large	<ul style="list-style-type: none"> • If ExtFaults = Step size over flow then GearOut/GearIn is too large. • If ExtFaults = Position error over flow then the following error (PosErr), has exceeded ± 128 revs. • Check if the motor is stalling or if the commanded speed is higher than the motor can achieve at the present bus voltage.
20	Option Card Fault	<ul style="list-style-type: none"> • If ExtFaults is AuxFBFault, then the AuxFB device is in error. • Check the AuxFB faults: AuxFBEnDatFlt, AuxFBPTCFIt or AuxFBSCDFIt. • Check to make sure that the drive is set up for the correct feedback device and that the device is functioning correctly. If ExtFaults is "No ExtendedFault," then this was a fault induced by the controller, such as SynqLost.

12 Resolver Interface Option Module

The Resolver Interface Option module can be installed in the 230V or 460V Smart Drive. It cannot be installed in an S200-DLS Drive or the Smart Drive NextGen. This section describes the Resolver Interface Option Module in detail.

12.1 Theory of Operation

The Resolver Interface Option Module provides the interface between the resolver and the drive's DSP. It is a tracking system where the rotor is excited with a sine wave. The outputs of the resolver are amplitude modulated by the sine and cosine of the rotor shaft angle. The tracking converter converts the sine and cosine amplitude ratio into a 12 bit number.

The module provides a 4 Vrms 5 kHz sine wave to excite the resolver rotor. The resolver transformer ratio is .5:1 so the stator outputs are 2V RMS with the shaft rotated to the angle of maximum coupling. The sine and cosine rotor outputs are returned to the resolver module's twin instrumentation amplifier inputs to produce a high common mode noise rejection and a high input impedance (220K Ω). The sine and cosine signals are then fed to a resolver to digital converter chip that performs the tracking conversion. The converter has both a serial output and an encoder emulator output. The serial output is read when the drive is powered up to obtain the absolute commutation angle for the motor. Thereafter, it is used as an encoder emulator.

The module is able to detect a loss of feedback by monitoring the sine and cosine signals. If both are near zero at the same time, a loss of feedback error is generated.

12.2 Installing the Resolver Module

1. If the Resolver Module is being installed in a 230V drive, remove the five screws at the corners of the cover and remove the cover. If the Resolver Module is being installed in a 460V drive, turn the 2 locking screws on the front of the drive clockwise and remove the MMC Smart Drive board from the drive chassis.
2. Remove the shunt from the 24-pin DIP socket located on the MMC Smart Drive board (See Figure 12-1 on page 312).
3. If there are not two standoffs already installed on either side of the 24-pin DIP socket on the MMC Smart Drive board, proceed to step 10.
4. If there are nylon standoffs snapped into the Resolver Module, remove and discard them. If there are nylon standoffs included with the Resolver Module, discard them.
5. Remove and save the two nylon screws that are threaded into the standoffs mounted to the MMC Smart Drive board.
6. Position the Resolver Module so the mounting holes align with the standoffs, and the header is aligned with the socket (See Figure 12-2 on page 313).
7. Using even pressure, press the option module into place.
8. Screw the Resolver Module to the standoffs using the screws removed in step 5.
9. Verify that the module is fully seated into the socket and proceed to step 15.
10. If there are standoffs installed in the Resolver Module, proceed to step 12.
11. Install the snap-in standoffs that were included with the Resolver Module into the Resolver Module. From the back of the Resolver Module (the side that has the 24-pin header on it), insert the short (slotted) end of the standoffs into the mounting holes.

12. Position the Resolver Module so the long (locking tab) end of the standoffs line up with the mounting holes on the Drive board, and the header is aligned with the socket (See Figure 12-2 on page 313).
13. Using even pressure, press the option module into place.
14. Verify that the module is fully seated into the socket and the locking tabs on the standoffs are in the locked position.
15. If the Resolver Module was installed in a 230V drive, re-install the cover and five screws removed in step 1. If the Resolver Module was installed in a 460V drive, re-install the MMC Smart Drive board into the chassis and turn the 2 locking screws on the front of the drive counter-clockwise to secure the front panel to the chassis.

Figure 12-1: : Before Shunt Removed and Resolver Module Installed

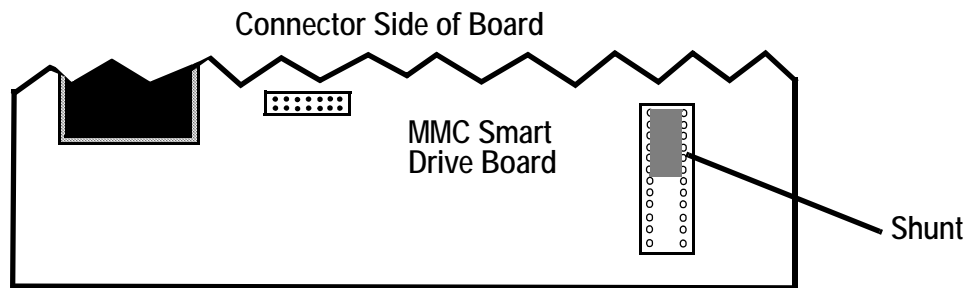
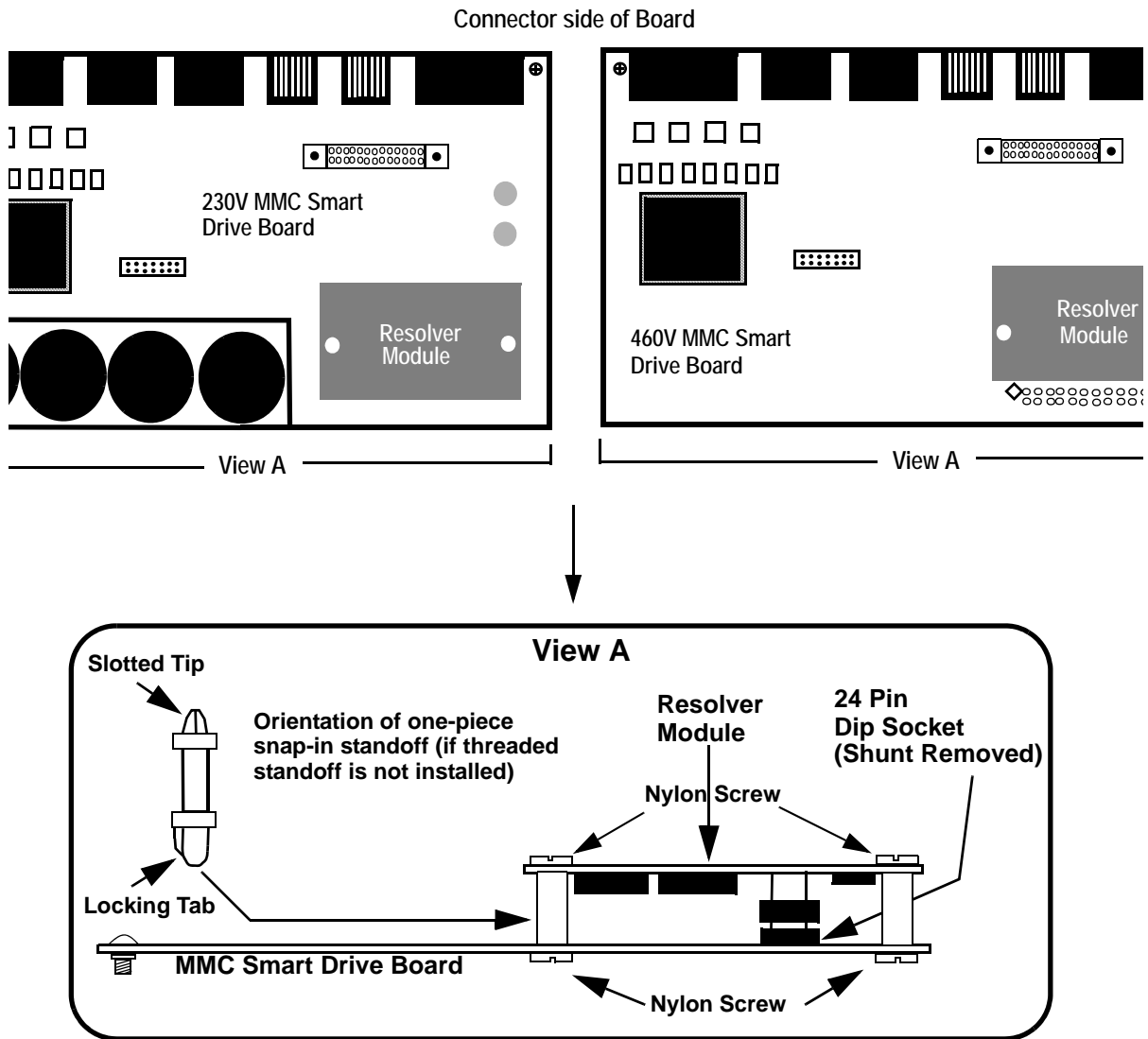

Figure 12-2: : Shunt Removed and Resolver Module Installed



12.3 Specifications

Characteristics	Resolver Interface Option Module Specifications
Part Number	M.1302.4523
Function	Resolver to encoder converter
Field Side Connector	F1 Feedback Connector
Excitation Frequency	5 kHz
Output Voltage	4 V _{RMS}
Current per Output Channel, max.	28 mA _{RMS}
Resolver Transformer Ratio	0.5:1.0
Resolver Resolution	4096 Feedback Units (FUs) per electrical revolution
Accuracy Over Temperature Range	+ 15 minutes
Electrical Velocity, max.	500 RPS
Cable Length, max.	30 M
Power	Powered from MMC Smart Drive

13 Drive Resident Digital MMC Control

The Drive Resident Digital MMC Control can be installed in the 230V or 460V Smart Drive. It cannot be installed in an S200-DLS Drive or the Smart Drive NextGen. This section describes the Drive Resident Digital MMC Control in detail.

13.1 Introduction

This section contains information for the Drive Resident Digital MMC Control (Digital MMC-Dx). Block I/O information can be found in the Block I/O Modules Manual. Software information can be found in the PiCPro Online Help, the Function/Function Block Reference Guide, ASFB Manuals or on-line.

13.1.1 Overview

The Drive Resident Digital MMC Control offers a complete solution to both machine and motion control in a module that is installed into any Digital Interfaced Smart Drive (MMC-SD-D) except the 230V Narrow Drive (-DN). One Drive Resident Digital MMC Control can control from 1 to 16 drives as follows:

- Digital MMC-D1 (controls one MMC-SD-D)
- Digital MMC- D2 (controls two MMC-SD-D)
- Digital MMC- D4 (controls four MMC-SD-D)
- Digital MMC- D8 (controls eight MMC-SD-D)
- Digital MMC- D16 (controls 16 MMC-SD-D)

PiCPro is used to program the Drive Resident Digital MMC Control. The built-in I/O (eight 24VDC inputs and eight 24VDC outputs) can be expanded using Kollmorgen serially distributed block I/O (not included on the Digital MMC-D1).

13.1.2 Major Components

The Drive Resident Digital MMC Control contains the CPU, a User Serial port, a Block I/O port, an Ethernet port, and a General I/O port consisting of 8 DC inputs and 8 DC outputs.

Figure 13-1: The Drive Resident Digital MMC Control

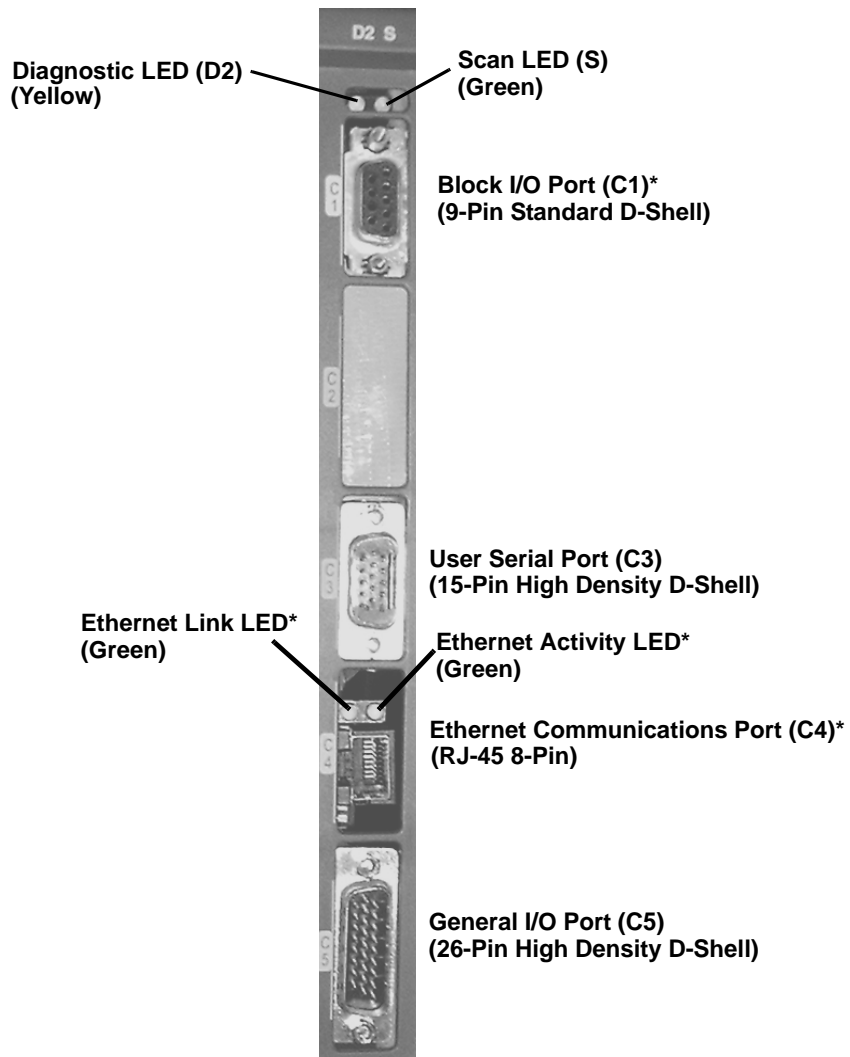

* The Block I/O Port connector (C1), Ethernet Communications Port connector (C4), Ethernet Link LED, and Ethernet Activity LED are present on the Digital MMC-D1 Control, but are not functional.

13.2 Installing the Drive Resident Digital MMC Control

13.2.1 Installing into a 230V MMC-SD Drive

1. Remove the three screws from the right side of the cover and one screw from the top and bottom of the drive near the front. Remove the cover.
2. Place the cover removed in step 1 on a flat surface, with the blue plastic faceplate down, and the large side cover to the left pointing up.
3. Remove the two screws that hold the .6" by 8" blue filler plate to the back of the faceplate and remove the plate.
4. Locate the 4 screws that secure the top-most printed circuit board into the drive. Remove one of the screws and the associated lock washer, and install one of the four threaded standoffs that were included with the Drive Resident Digital MMC Control (do not use the lock washer). Repeat this process for the other 3 screws, one at a time.
5. Place the Drive Resident Digital MMC Control into the drive, with the connectors facing towards the front of the unit. Align the 20-pin connector on the Drive Resident Digital MMC Control with the 20-pin connector on the drive. Press the Drive Resident Digital MMC Control onto the drive until the 20-pin connector is completely seated and the Drive Resident Digital MMC Control is seated against the threaded standoffs installed in step 4.
6. Fasten the Drive Resident Digital MMC Control onto the threaded standoffs using the lockwashers and screws removed in step 4.
7. Replace the cover using the 4 screws removed in step 1.

13.2.2 Installing into a 460V MMC-SD Drive

1. Turn the two locking screws on the front of the drive clockwise $\frac{1}{4}$ turn and pull the drive control board unit out of the drive.
2. Place the drive control board unit removed in step 1 on a flat surface, with the blue plastic faceplate down, and the drive control board to the left.
3. Remove the two screws that hold the .6" by 8" blue filler plate and remove the plate.
4. Place the drive control board unit on a flat surface so that the control board is facing up, and the blue plastic faceplate is facing away from you.
5. Locate the 4 screws that secure the top-most printed circuit board into the drive. Remove one of the screws and the associated lock washer, and install one of the four threaded standoffs that were included with the Drive Resident Digital MMC Control (do not use the lock washer). Repeat this process for the other 3 screws, one at a time.
6. Place the control board unit on a flat surface, with the blue plastic faceplate down, and the drive control board to the left.
7. Loosen (but do not remove....about 2 turns) the 5 screws that hold the drive control board mounting plate to the front cover plate.
8. Place the Drive Resident Digital MMC Control into the drive, inserting the connectors on the Drive Resident Digital MMC Control through the front plate.
9. Align the 20-pin connector on the Drive Resident Digital MMC Control with the 20-pin connector on the drive. Press the Drive Resident Digital MMC Control onto the

drive until the 20-pin connector is completely seated and the Drive Resident Digital MMC Control is seated against the threaded standoffs installed in step 5.

10. Tighten the 5 screws loosened in step 7
11. Fasten the Drive Resident Digital MMC Control onto the threaded standoffs using the lockwashers and screws removed in step 5.
12. Replace the control board unit back into the drive, and turn the locking screws $\frac{1}{4}$ turn counter-clockwise to secure the unit in place.

13.3 System Wiring Guidelines

The Drive Resident Digital MMC Control relies on electrical signals to report what is going on in the application and to send commands to it. In addition, signals are constantly being exchanged within the system. The Drive Resident Digital MMC Control is designed for use in industrial environments, but some guidelines should be followed.

Figure 13-2: Recommended EMC Compliant Connections

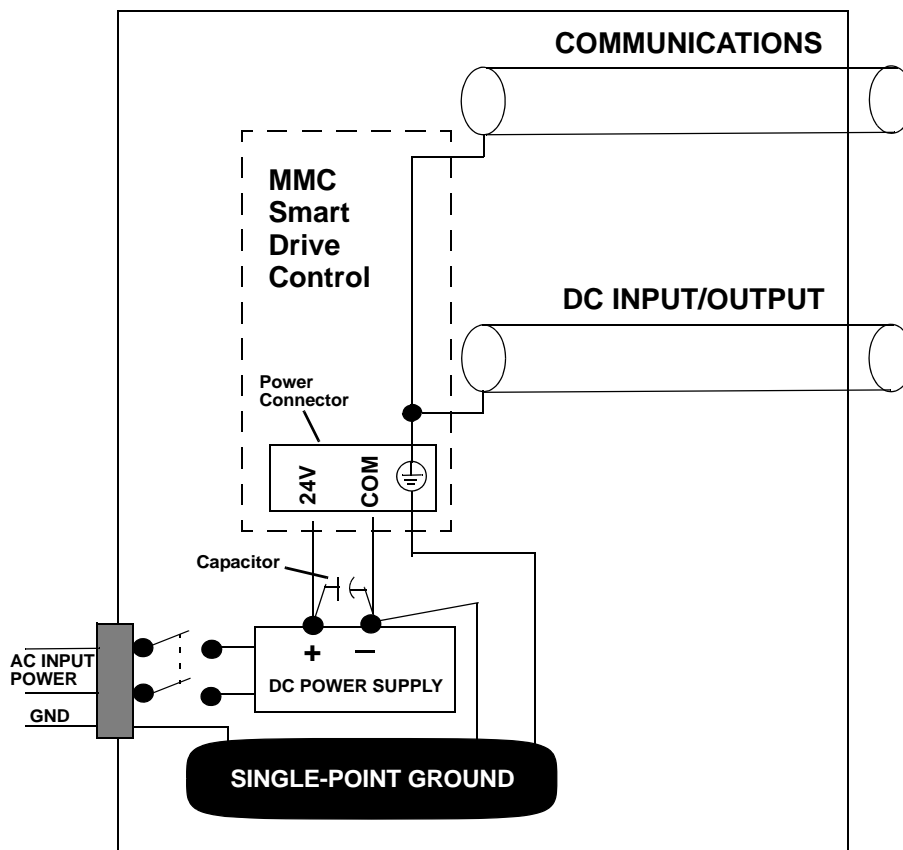

Inside a control cabinet, connect the shields of shielded cables. The two different methods of terminating shields are used to accommodate two different immunity requirements. Immunity required inside an enclosure is considered lower because cables are typically less than three meters in length and/or can be separated from each other and from noise sources.

Immunity required external to an enclosure is considered higher because the user may have less control over the noise environment. Low level signal cables that can be external to an enclosure are tested at a 2 KV level for electrical fast transients (EFTs).

Low level signals that can be less than three meters in length or can be separated from noise sources are tested at a 1 KV level. Under the stated conditions, there will be no disturbance of digital I/O, encoder, or encoder operation. For analog signals, there may be momentary disturbances but there will be self-recovery when the noise subsides.

Do not operate transmitters, arc welding equipment, or other high noise radiators within one meter of an enclosure that has the door open. Continue to equip inductive devices, if they are in series with a mechanical contact or switch, with arc suppression circuits. These devices include contactors, solenoids and motors. Shield all cables that carry heavy current near the system, using continuous foil wrap or conduit grounded at both ends. Such cables include power leads for high-frequency welders and for pulse-width-modulated motor drives.

WARNING

Use care when wiring I/O devices to the Drive Resident Digital MMC Control and when plugging in cables. Wiring the wrong device to the connector or plugging a connector into the wrong location could cause intermittent or incorrect machine operation.

13.4 Starting an Operation

Good procedure suggests that the system should be tested each time a new application is powered up. The Diagnostic LED (D2) on the Drive Resident Digital MMC Control should be off indicating that the diagnostic tests were passed.

Turn off the main disconnect switch and plug the DC connector into the power connector on the MMC-SD. Turn on input power. The D2 LED turns on and then turns off when the Drive Resident Digital MMC Control passes its diagnostic tests.

13.4.1 Connecting the Drive Resident Digital MMC Control to the Application

1. Turn off the main disconnect switch in the control cabinet. If some devices are not powered from the control cabinet, turn them off also.
2. Connect the connectors according to your diagrams.
3. Turn on power to the system. The PWR light on the MMC-SD goes on and stays on.
The D2 light goes on, then goes off in turn.
The SCAN (S) light goes on.
The application starts to work under control of the system.
4. If an application program is not in system memory, use the download command in the PiCPro software to place it there.

13.4.2 Basic Setup and Maintenance Procedures

[Table 13-1](#) below summarizes how to proceed when performing certain maintenance and/or setup functions.

Table 13-1: Troubleshooting Summary	
In order to:	Do the following:
Turn off the entire application.	Turn off main disconnect (which should also turn off all external power supplies to the application); unplug the DC power to the MMC-SD.
Wire the I/O to the application.	Turn off main disconnect (which should also turn off all external power supplies to the application); unplug the DC power to the MMC-SD.
Change the battery.	Turn off main disconnect (which should also turn off all external power supplies to the application); unplug the DC power to the MMC-SD.
Connect/disconnect the MMC with the computer workstation through the PiC-Pro port.	Turn off main disconnect (which should also turn off all external power supplies to the application); unplug the DC power to the MMC-SD.
Connect/disconnect the MMC with an operator interface through the User port.	Turn off main disconnect (which should also turn off all external power supplies to the application); unplug the DC power to the MMC-SD.
Download an application program into the memory.	Make sure power is on (check the P LED) on the MMC-SD.
Stop the scan.	From the workstation - use the Stop Scan commands in the PiCPro software.

13.4.3 Start-up Diagnostics

When the system is powered up, it tests itself and reports the results in the form of LED signals.

13.4.3.1 Power LED

If the Power LED (P) on MMC-SD does not go on, or goes off during operation of the system, check that power is still connected to the MMC-SD. If the power LED on the MMC-SD is on, turn off the main disconnect switch and replace the Drive Resident Digital MMC Control.

13.4.3.2 Scan LED

If the SCAN (S) LED does not go on:

1. Check that the power (P) light is ON.
2. Check that the diagnostic (D2) light is OFF.

13.4.3.3 Drive Resident Digital MMC Control Start-Up Diagnostic LEDs

The LED D2 light on the Drive Resident Digital MMC Control lights up briefly while its diagnostic tests are running and then goes off. If D2 remains on, the Drive Resident Digital MMC Control has failed one of its tests. Follow these steps:

1. Turn off power to the system and to the application.
2. If the I/O wiring is connected, remove the connector.
3. Remove the defective Drive Resident Digital MMC Control from the drive.
4. Replace with a new Drive Resident Digital MMC Control. Connect the I/O wiring.
5. Turn on power to check diagnostics again.

NOTE
Diagnostics are run only when the system is powered up. It is possible that a failure might occur during operation. If so, D2 remains on. If you suspect that a module might be defective, cycle power to run diagnostics again.

13.4.4 MMC Run-Time Diagnostics

While the Drive Resident Digital MMC Control is running, other tests are performed on a regular basis with their results also reported by D2.

While the Drive Resident Digital MMC Control is running, the D2 will flash a three digit code signal if there is an error. For example, if there is a long pause-flash-pause-flash-flash-pause-flash-flash-flash-long pause, the code is 123.

Code	Error	Description
123	Scan too long	A ladder scan loss has occurred because the CPU takes more than 200 ms to scan the application program. Whenever the scan light is out, the discrete outputs go to the OFF state and the analog outputs are zeroed.
124	Excessive overhead	The system overhead update time is excessive.
125	Insufficient memory	There is insufficient memory on the CPU to run the current program.
126	No hardware bit memory	There is no bit memory installed on the CPU and the program requires it.
127	No software bit memory	There is no bit memory capability via software and the program requires it.
222	Driver error	No driver support on the CPU for the I/O module. Update your system EPROMs.
22_	Master rack error	The I/O modules in the master rack do not match what was declared in the hardware master declaration table. The number of flashes in the third digit (__) identifies the slot number that is in error.
232	Communications error	A failure has occurred in remote I/O communications.
3_ _	Expansion rack error	The I/O modules in the block I/O modules do not match what was declared in the expansion hardware declaration table. For block I/O modules: The number of flashes in the second and third digits indicates the block I/O module (01 through 77). The second digit will flash a 1 - 7, 10 for 0. The third digit will flash a 1 - 9, 10 for 0. For example, if the second digit flashes 3 times and the third digit flashes 10 times, the module is 30 .
621	Low Battery	The battery on the Control is near its end of life, and needs to be replaced.

13.5 Connectors & Operation

Kollmorgen provides many optional accessories that simplify wiring the Drive Resident Digital MMC Control to external devices.

These accessories include cables to connect MMC-SD drives together and breakout boxes that provide screw-terminal connections to the Drive Resident Digital MMC Control. Contact Kollmorgen for further information.

13.5.1 PiCPro Port (P1)

The PiCPro Port (P1) connector provides serial communication for the PiCPro programming interface. PiCPro Port (P1) is physically located on the MMC-SD faceplate. Refer to Chapter 5 for information on the PiCPro (P1) Port.

Note: PiCPro can also be run over from the Ethernet (C4) connector.

13.5.2 Block I/O Port (C1)

The 9-pin female D-sub PiCPro Port connector (labeled “C1” on the front of the Control) provides serial communication between 1 to 77 Block I/O modules and the Control. Cables connecting the Control to the first Block I/O Module and between Block I/O modules can be up to 200 feet in length.

Note: The Block I/O Port (C1) is not included on the Digital MMC-D1.

- Pin descriptions for are provided in [Table 13-3](#).
- Pin assignments are provided in [Table 13-4](#).
- The available Flying Lead cable is described in [Table 13-5](#).
- Connections to the Block I/O Module are described in [Table 13-6](#).
- Available Breakout Boxes and Cables are described in [Table 13-7](#).
- Breakout Box dimensions are shown in [Figure 13-3](#)

Table 13-3: Block I/O Port Pin Descriptions

Function	Notes	Pin
Transmit Data +	Transmits data to Block I/O Modules.	3
Transmit Data -	Transmits data to Block I/O Modules.	4
Receive Data +	Receives data from Block I/O Modules.	5
Receive Data -	Receives data from Block I/O Modules.	6
Shield Ground	Provides a path for shield current through the chassis to an external single point ground.	7 & Shell

Table 13-4: Block I/O Port Pin Assignment

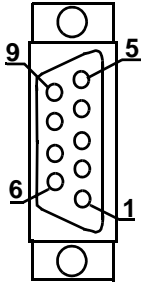
Pin	Signal	In/Out	Connector Pinout
1	NC	N/A	9-pin female D-sub 
2	N/C	N/A	
3	Transmit Data +	Out	
4	Transmit Data -	Out	
5	Receive Data +	In	
6	Receive Data -	In	
7	Shield	In	
8	NC	N/A	
9	NC	N/A	
Connector Shell	Drain	In	

NOTE

Pin 7 of the Block I/O port connector is connected to the connector shell within the MMC. Therefore, the shield may be connected to either pin 7 or the connector shell.

Table 13-5: Block I/O Port to Flying Lead Cable

Part Number: M.1016.2568
 Length: 3 M (10 ft)
 Cable type: 24 AWG, twisted pair (individually shielded), 4 conductor.

9-Pin male D-sub (to Block I/O Port, face view)

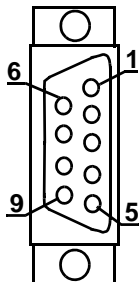

Pin	Signal	Color	Notes
3	Transmit Data +	White	Twisted Pair with Shield
4	Transmit Data -	Black	
7	Shield	N/A	
5	Receive Data +	Red	Twisted Pair with Shield
6	Receive Data -	Black	
7	Shield	N/A	

Table 13-6: Block I/O Port to Block I/O Module Wiring				
Use this table to wire from the Block I/O Port to the first Block I/O Module.				
9-Pin male D-sub (to Block I/O Port, face view)		5-Pin Pluggable Screw Terminal (to Block I/O Module, face view)		
				
Pin	Signal	Pin	Signal	Notes
3	Transmit Data +	1	Receive Data +	Twisted Pair
4	Transmit Data -	2	Received Data -	
5	Receive Data +	4	Transmit Data +	Twisted Pair
6	Received Data -	5	Transmit Data -	
7	Shield Ground	3	Shield Ground	
Shell	Drain	Shell	Drain	

Table 13-7: Block I/O Port Breakout Box and Cables ^a		
Description	Length	Part Number
MMC Block I/O Breakout Box	N/A	M.1016.2533
MMC Block I/O Connector to Breakout Box Cable	.3 M (1 ft)	M.1016.2543
MMC Block I/O Connector to Breakout Box Cable	.6 M (2 ft)	M.1016.2544
MMC Block I/O Connector to Breakout Box Cable	.9 M (3 ft)	M.1016.2545

a. The Breakout Box (see [Figure 13-3 on page 327](#)) is DIN-rail mounted, and provides screw terminal wire termination. It can be attached to the “C1” port on the Control. The pinouts on the terminal strip interface provide a one-to-one transfer of the signals from the connector to the respective pin(s) on the terminal block. The connector pins marked with the “ground” symbol on the screw connector are connected to the “D” connector shell for shield grounding purposes.

Figure 13-3: Block I/O Breakout Box Dimensions

13.5.3 User Port

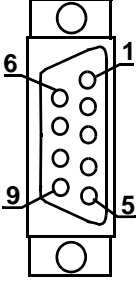
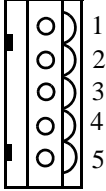
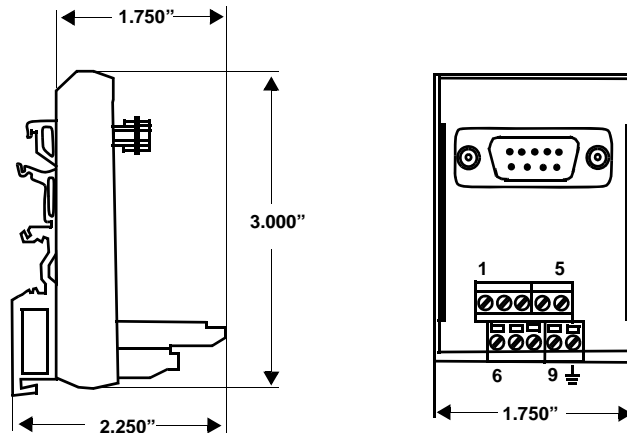
The 15-pin HD male D-sub User Port connector (labeled “C3” on the front of the Control) provides RS232 and RS485 serial communication between a serial device and the Control. The User Port provides RS232/RS485 communications at Baud rates to 115.2 K with Multidrop capability.

- Pin descriptions are provided in [Table 13-8](#)
- Pin assignments are provided in [Table 13-9](#)
- The available Flying Lead cable is described in [Table 13-10](#).
- The available RS-232 Exter HMI cable is described in [Table 13-11](#).
- The available RS-485 Exter HMI cable is described in [Table 13-12](#).
- Available Breakout Boxes and Cables are described in [Table 13-13](#).
- Breakout Box dimensions are shown in [Figure 13-4](#)

Table 13-8: User Port Pin Descriptions		
Function	Notes	Pin
RS232 Receive Data	RS232-level signal that receives serial data from the connected serial device.	9
RS232 Transmit Data	RS232-level signal that sends serial data to the connected serial device.	10
RS232 Request-to-send	RS232-level signal that indicates to the connected serial device that it can transmit data to the Control.	5
RS232 Clear-to-send	RS232-level signal that indicates to the Control that it can transmit data to the connected serial device.	7
RS-232 Data-terminal-ready	This output from the Control is always high (12 Vdc).	4
RS-485 Receive Data +	RS485-level signal that receives serial data from the connected serial device(s).	12
RS-485 Receive Data -	RS485-level signal that receives serial data from the connected serial device(s).	13
RS-485 Transmit Data +	RS485-level signal that transmits serial data to the connected serial device(s).	14
RS-485 Transmit Data -	RS485-level signal that transmits serial data to the connected serial device(s).	15
Signal Ground	Provides the return path for signals	8
Shield Ground	Provides a path for shield current through the chassis to an external single point ground.	Shell

Table 13-9: User Port Pin Assignments			
Pin	Signal	In/Out	Connector Pinout
1	NC	N/A	15-pin HD male D-sub 
2	N/C	N/A	
3	N/C	N/A	
4	RS232 Data-terminal-ready (12 Vdc)	Out	
5	RS232 Request-to-Send	Out	
6	N/C	N/A	
7	RS232 Clear- to-Send	In	
8	Signal Ground	In/Out	
9	RS232 Receive Data	In	
10	RS232 Transmit Data	Out	
11	N/C	N/A	
12	RS485 Receive Data +	In	
13	RS485 Receive Data -	In	
14	RS485 Transmit Data +	Out	
15	RS485 Transmit Data -	Out	
Connector Shell	Drain	In	

Table 13-10: User Port to Flying Lead Cable

Part Number: M.1016.2565
 Length: 3 M (10 ft)
 Cable type: 28 AWG, shielded, twisted pair, 16 conductor.

15-Pin HD female D-sub (to User Port, face view)

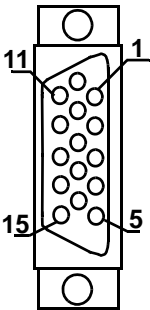
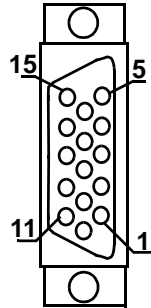

Pin	Signal	Color	Notes
3	N/C	Blue	Twisted
8	Signal Ground	Blue/Black	Pair
12	RS485 Receive Data +	Brown	Twisted
13	RS485 Receive Data -	Brown/Black	Pair
14	RS485 Transmit Data +	Violet	Twisted
15	RS485 Transmit Data -	Violet/Black	Pair
4	RS232 Data-terminal Ready	White	
5	RS232 Request-to-send	Red	
7	RS232 Clear-to-send	Green	
9	RS232 Receive Data	Yellow	
10	RS232 Transmit Data	Orange	
Shell	Drain	N/A	

Table 13-11: User Port to RS-232 Exter HMI Cable

Part Number: M.1302.8453 Length: 4 M (13 ft) Cable type: 24 AWG, shielded, twisted pair, 4 conductor.				
15-Pin HD female D-sub (to User Port, face view)		9-Pin female D-sub (to Exter HMI COM2 Port, face view)		
Pin	Signal	Pin	Signal	Notes
9	Receive Data	3	Transmit Data	Twisted
10	Transmit Data	2	Receive Data	Pair
8	Signal Ground	5	Signal Ground	
Shell	Drain	Shell	Drain	

Table 13-12: User Port to RS-485 Exter HMI Cable

Part Number: M.1302.8454 Length: 4 M (13 ft) Cable type: 24 AWG, shielded, twisted pair, 6 conductor.				
15-Pin HD female D-sub (to User Port, face view)		25-Pin male D-sub (to Exter HMI COM1 Port, face view)		
Pin	Signal	Pin	Signal	Notes
12	Receive Data+	2	Transmit Data+	Twisted
13	Receive Data-	15	Transmit Data-	Pair
14	Transmit Data+	3	Receive Data+	Twisted
15	Transmit Data-	16	Receive Data-	Pair
8	Signal Ground	7	Signal Ground	
Shell	Drain	Shell	Drain	

Table 13-13: User Port Breakout Box and Cables^a

Description	Length	Part Number
MMC User Port Breakout Box	N/A	M.1016.2530
MMC User Port to Breakout Box Cable	.3 M (1 ft)	M.1016.2715
MMC User Port to Breakout Box Cable	.6 M (2 ft)	M.1016.2716
MMC User Port to Breakout Box Cable	.9 M (3 ft)	M.1016.2717

a. The Breakout Box (see [Figure 13-4 on page 333](#)) is DIN-rail mounted, and provides screw terminal wire termination. It can be attached to the “C3” connector on the Control. The pinouts on the terminal strip interface provide a one-to-one transfer of the signals from the connector to the respective pin(s) on the terminal block. The connector pins marked with the “ground” symbol on the screw connector are connected to the “D” connector shell for shield grounding purposes.

Figure 13-4: User Port Breakout Box Dimensions

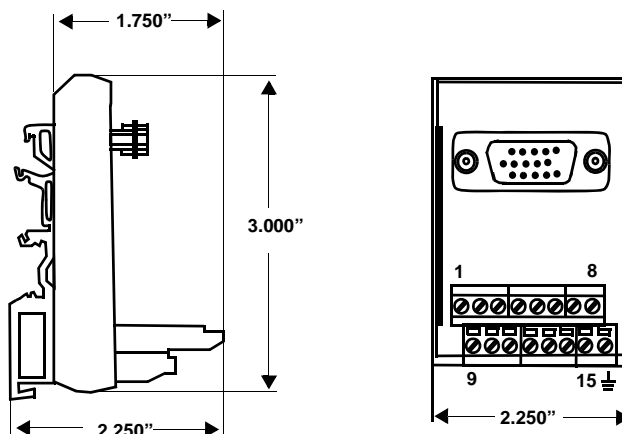

13.5.4 Ethernet Port

The 8-pin RJ-45 Ethernet Port connector (labeled “C4” on the front of the Control) provides IEEE 802.3/802.3u-100Base-TX/10Base T, half duplex connectivity between an Ethernet device and the Control. Also provided on near the RJ-45 connector is a green “Link” light (which will be on if there is either a 100Base-T or 10Base-T Link) and a green “Activity” light (which will be on whenever a send or receive packet has occurred on the network).

Communication using the Ethernet Port can be between the Control and a PC, User Interface, or other Ethernet device or network. For example, PiCPro running on a PC can communicate to the Control through this Ethernet connector.

Typically, a “straight-through” shielded cable should be used when connecting the Control to another Ethernet device.

- Pin descriptions for are provided in [Table 13-14](#)
- Pin assignments are provided in [Table 13-15](#)
- The available Ethernet Port to Ethernet Device cables are described in [Table 13-16](#)

Table 13-14: Ethernet Port Pin Descriptions		
Function	Notes	Pin
Receive Data +	Receives data from connected device.	3
Receive Data -	Receives data from connected device.	6
Transmit Data +	Transmits data to connected device.	1
Transmit Data -	Transmits data to connected device.	2

Table 13-14: Ethernet Port Pin Descriptions		
Function	Notes	Pin
Shield Ground	Provides a path for shield current through the chassis to an external single point ground.	Shell

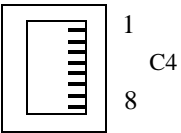
Table 13-15: Ethernet Port Pin Assignments			
Pin	Signal	In/Out	Connector Pinout
1	Transmit Data +	Out	RJ-45 
2	Transmit Data -	Out	
3	Receive Data +	In	
4	Termination Resistors ^a	In	
5	Termination Resistors ^a	In	
6	Receive Data -	In	
7	Termination Resistors ^a	In	
8	Termination Resistors ^a	In	
Connector Shell	Shield	In	

a. Pins 4, 5, 7, and 8 are tied to termination resistors on the Control. Standard Ethernet cables contain 8 wires. The Control only uses 4 of these wires as shown. Connecting the 4 unused wires to pins 4, 5, 7, and 8, (as will be done in a standard Ethernet cable) reduces noise that can be induced from the unused wires to the Transmit and Receive wires.

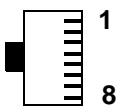
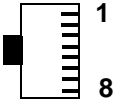
Table 13-16: Ethernet Port to Ethernet Device Cables				
Part Numbers: .3 M (1.0 ft): M.1302.8285 .6 M (2.0 ft): M.1302.8286 1 M (3.3 ft): M.1302.8287 2 M (6.6 ft): M.1302.8288 3 M (9.8 ft): M.1302.8289 5 M (16.4 ft): M.1302.8300 10 M (32.8 ft): M.1302.8301 15 M (49.2 ft): M.1302.8302 30 M (98.4 ft): M.1302.8303 Cable type: 28 AWG, shielded, twisted pair, 8 conductor.				
8-Pin RJ-45 Plug (to Ethernet Port, face view) 		8-Pin RJ-45 Plug (to Ethernet Device, face view) 		
Pin	Signal	Pin	Signal	Notes
1	Transmit Data +	1	Receive Data +	Twisted
2	Transmit Data -	2	Receive Data -	Pair
3	Receive Data +	3	Transmit Data +	Twisted
6	Receive Data -	6	Transmit Data -	Pair
4	None	4	None	Twisted
5	None	5	None	Pair
7	None	7	None	Twisted
8	None	8	None	Pair
Shell	Drain	Shell	Drain	

13.5.5 General I/O Port (C5)

The 26-pin HD male D-sub General I/O Port connector (labeled “C5” on the front of the Control) provides connection between user I/O devices and the Control. This port provides 8 source-only, 250ma, short-circuit protected outputs (described in detail in [section 13.5.5.1 on page 340](#)), and 8 source-only inputs (described in detail in [section 13.5.5.2 on page 342](#)).

- Pin descriptions are provided in [Table 13-17](#)
- Pin assignments are provided in [Table 13-18](#)
- The available Flying Lead cable is described in [Table 13-19](#).
- Available Breakout Boxes and Cables are described in [Table 13-20](#).
- Breakout Box dimensions are shown in [Figure 13-5](#)

Table 13-17: General I/O Port Pin Descriptions		
Function	Notes	Pin
DC Outputs 1-8	Nominal 24 Vdc Outputs capable of sourcing up to 250 ma.	1-8
DC Inputs 1-8	Nominal 24 Vdc sourcing Inputs	19-26
DC Output Power	This is the 24 Vdc supplied by the user to power the DC Outputs	9
I/O 24 Volts	These pins are only connected to each other within the Control. If used, connect one pin to 24 Vdc, and the other pins to one side of input devices.	10-13
24 Vdc Common	These pins are only connected to each other within the Control. Connect pin 14 to 24V Common. This provides the return path for the 24 Vdc Inputs. Connect pins 15-18 to one side of output devices if desired.	14-18
Shield Ground	Provides a path for shield current through the chassis to an external single point ground.	Shell

Table 13-18: General I/O Port Pin Assignments			
Pin	Signal	In/Out	Connector Pinout
1	DCOUT1	Out	<p>26-pin HD male D-sub</p> 
2	DCOUT2	Out	
3	DCOUT3	Out	
4	DCOUT4	Out	
5	DCOUT5	Out	
6	DCOUT6	Out	
7	DCOUT7	Out	
8	DCOUT8	Out	
9	24VDCIN	In	
10-13	IO24V	In/Out	
14-18	IO24C	In/Out	
19	DCIN1	IN	
20	DCIN2	IN	
21	DCIN3	IN	
22	DCIN4	IN	
23	DCIN5	IN	
24	DCIN6	IN	
25	DCIN7	IN	
26	DCIN8	IN	
Shell	Drain	In	

Table 13-19: General I/O Port to Flying Lead Cable

Part Numbers:
 1 M (3.3 ft): M.1302.8257 15 M (49.2 ft): M.1302.8290
 3 M (10 ft): M.1302.8258 30 M (98.4 ft): M.1302.8291
 9 M (29.5 ft): M.1302.8259
 Cable type: 28 AWG (pins 9 & 10 are 20 AWG), shielded, twisted pair, 26 conductor.

26-Pin HD female D-sub (to Gen I/O Port, face view)

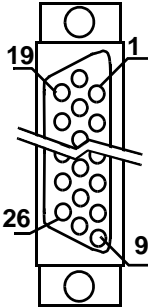
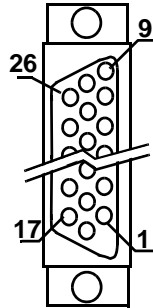

Pin	Signal	Color	Notes	Pin	Signal	Color	Notes
1	DCOUT1	Blk	Twisted	15	IO24C	Brn	Twisted
2	DCOUT2	Wht/Blk	Pair	16	IO24C	Wht/Brn	Pair
3	DCOUT3	Red	Twisted	17	IO24C	Vio	Twisted
4	DCOUT4	Wht/Red	Pair	18	IO24C	Wht/Vio	Pair
5	DCOUT5	Grn	Twisted	19	DCIN1	Pnk	Twisted
6	DCOUT6	Wht/Grn	Pair	20	DCIN2	Wht/Pnk	Pair
7	DCOUT7	Org	Twisted	21	DCIN3	Blk/Yel	Twisted
8	DCOUT8	Wht/Org	Pair	22	DCIN4	Gry/Grn	Pair
9	24VDCIN	Gry	Twisted	23	DCIN5	Grn/Red	Twisted
10	IO24V	Wht/Gry	Pair	24	DCIN6	Yel/Red	Pair
11	IO24V	Blu	Twisted	25	DCIN7	Gry/Blu	Twisted
12	IO24V	Wht/Blu	Pair	26	DCIN8	Yel/Blu	Pair
13	IO24V	Yel	Twisted				
14	IO24C	Wht/Yel	Pair				
Shell	Drain	N/A					

Table 13-20: General I/O Port Breakout Box and Cables ^a		
Description	Length	Part Number
DR Control Gen I/O Breakout Board ^b	N/A	M.1302.8480
DR Control Gen I/O Breakout Box ^c	N/A	M.1302.8253
DR Control Gen I/O & Aux I/O Connector to Breakout Box Cable	1 M (3.3 ft)	M.1302.8254
	3 M (9.8 ft)	M.1302.8255
	9 M (29.5 ft)	M.1302.8256

- a. The connector pins marked with the “ground” symbol on the screw connector are connected to the “D” connector shell for shield grounding purposes.
- b. The Breakout Board is mounted directly to the General I/O connector, and provides screw terminals wire termination.
- c. The Breakout Box (see [Figure 13-5 on page 339](#)) is DIN-rail mounted, and provides screw terminal wire termination. Use one of the cables listed in the table to connect between the General I/O connector and the Breakout Box.

Figure 13-5: General I/O Port Breakout Box Dimensions

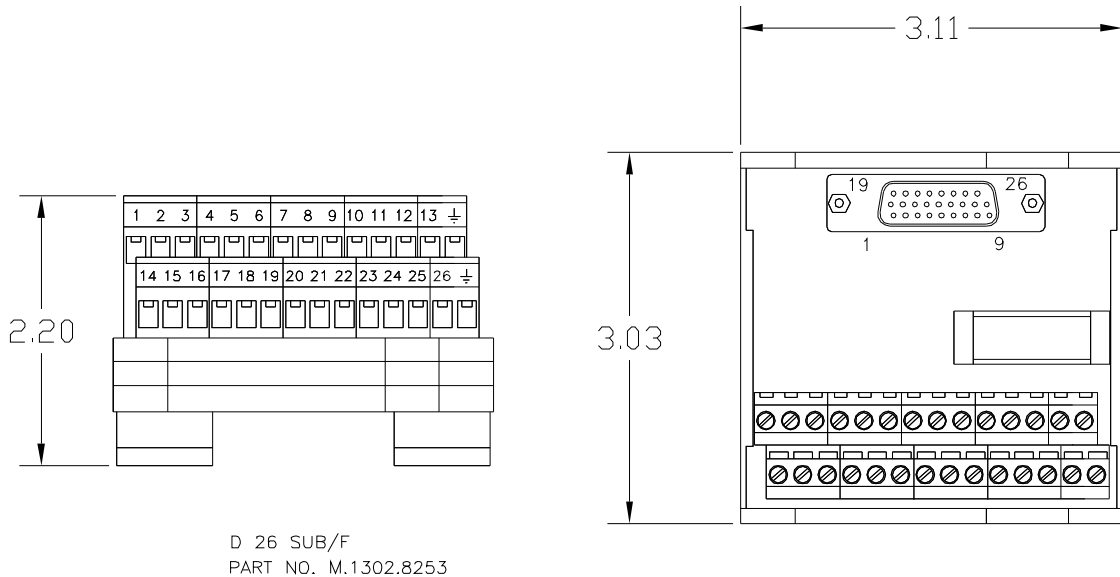
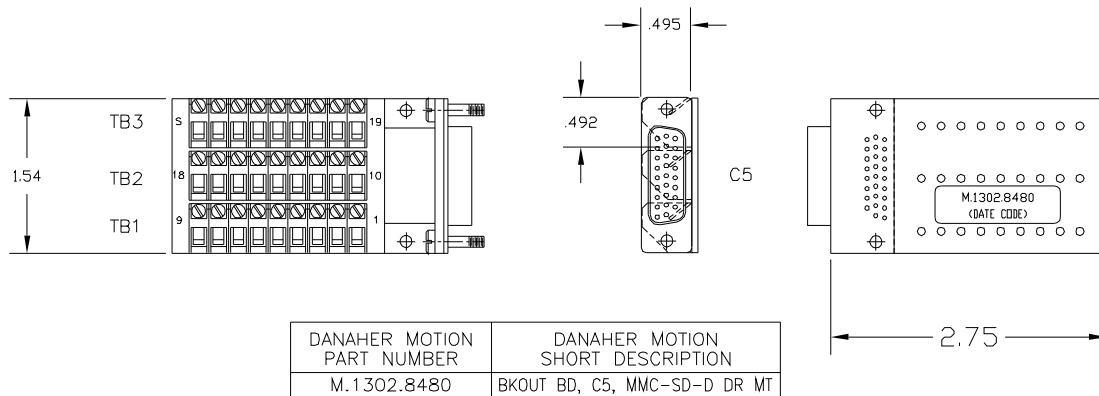

Figure 13-6: General I/O Port Breakout Board Dimensions



13.5.5.1 DC Output Operation

The General I/O Port provides 8 source-only 24 Vdc outputs. These outputs get their power from Pin 9 of the General I/O connector. Each of the 8 outputs on the general I/O connector is a solid state switch rated at 250 ma. An example of connecting the DC Outputs to loads is shown in [Figure 13-7](#).

When a short circuit condition is sensed, all outputs in the group are turned off and remain off for approximately 100 ms regardless of ladder activity. After 100 ms, the ladder again controls the outputs. In addition, each output is protected with internal clamping diodes. Without clamping, high voltage transients (kickback) from inductive loads might damage the module.

For safety reasons, all outputs turn off (no current flow) when a scan loss condition occurs.

Figure 13-7: Connecting Output Devices to the General I/O Port (C5)

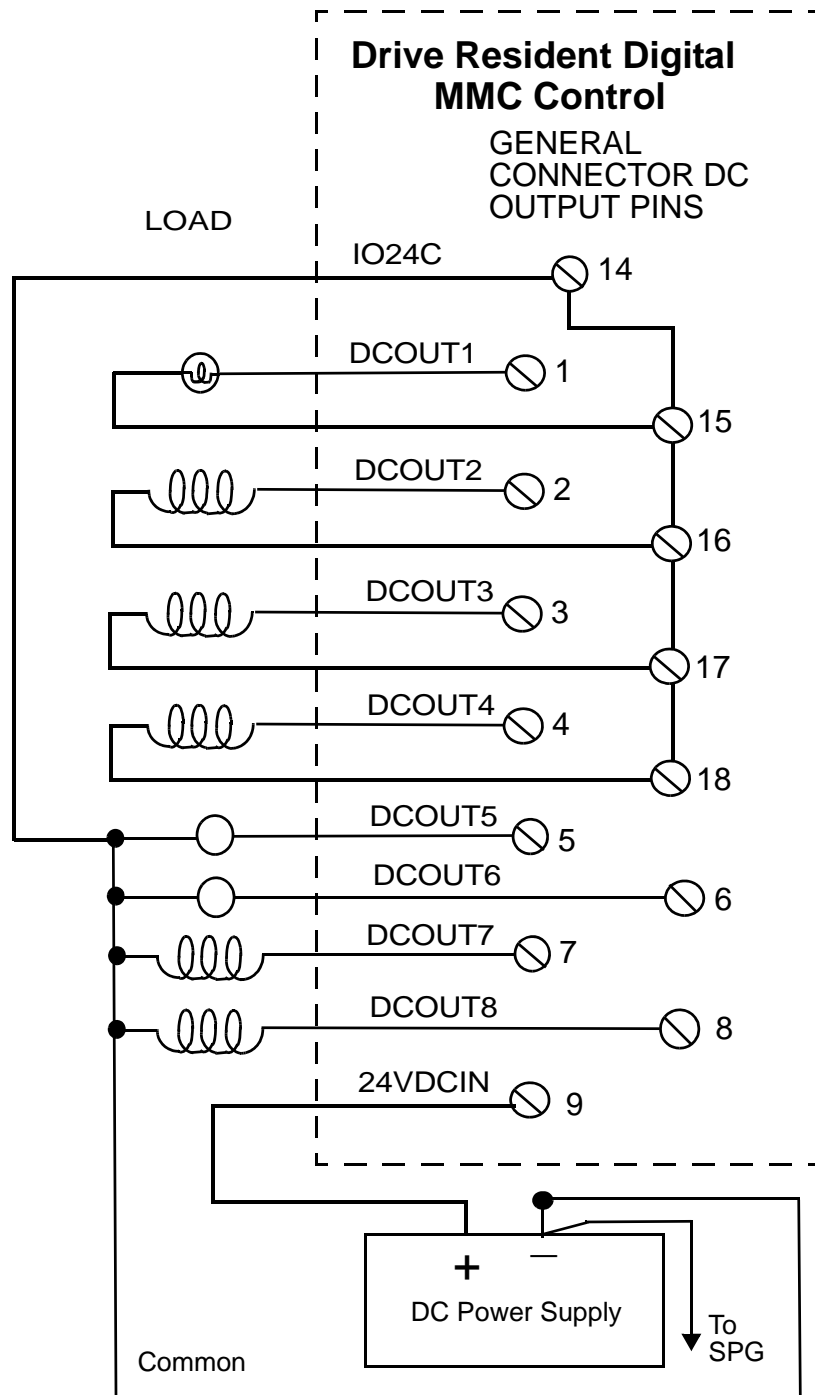

13.5.5.2 DC Input Operation

The General I/O Port provides eight 24 Vdc sourcing inputs.

An example of connecting the DC Inputs to the Control is shown in [Figure 13-8](#).

Figure 13-8: Connecting Input Devices to the General I/O Port (C5)

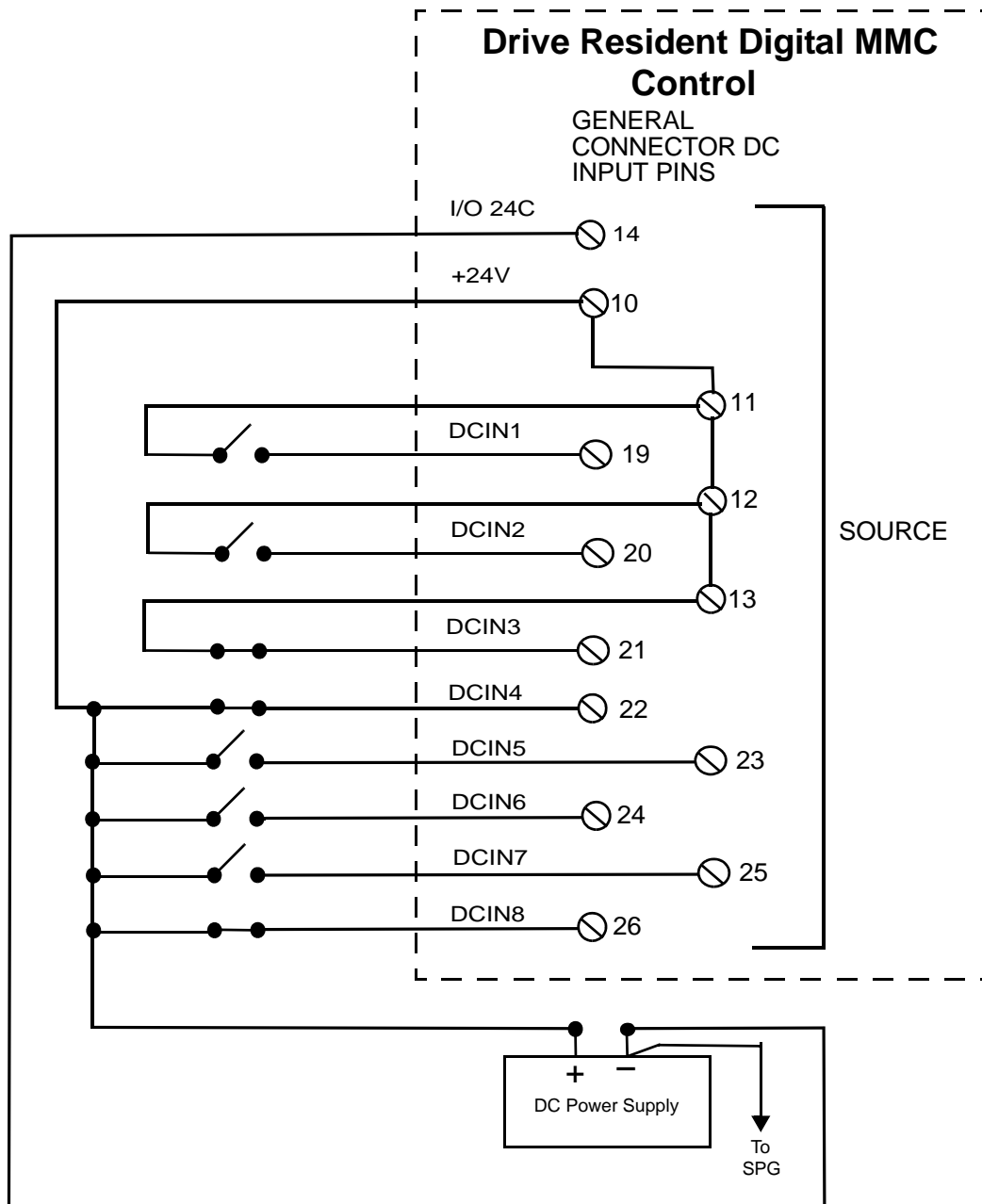

13.6 Specifications

Table 13-21: Part Numbers										
Model & Part Numbers		Memory			Number of servo axes available at indicated update rate ^a					
Model	Part No.	App Mem	RAM Mem	User Mem	8 ms	4 ms	2 ms	1 ms	.5 ms	.25 ms
Digital MMC-D1	M.3000.0164	1.3M	256K	64K	1	1	1	1	1	1
Digital MMC-D2	M.3000.0165	1.3M	256K	64K	2	2	2	2	2	1
Digital MMC-D4	M.3000.0166	1.3M	256K	64K	4	4	4	4	2	1
Digital MMC-D8	M.3000.0518	1.3M	256K	64K	8	8	8	4-8	2-4	1-2
Digital MMC-D16	M.3000.0167	1.3M	256K	64K	16	16	8-16	4-8	2-4	1-2

a. Using features such as servo tasks, S-curve, `RATIO_RL`, `M_LINCIR`, `M_SCRVLC`, `PLS`, and `CAM_OUT` places a heavier burden on available CPU time. Consult Kollmorgen for assistance if you want to exceed the number of axes in this chart.

Table 13-22: General Specifications	
CPU	32 bit RISC processor with numeric coprocessor
Battery	3V Coin Cell, BR2032 lithium battery
Battery Life	2 power-off years (typical)
CAUTION for Lithium Batteries Danger of explosion if battery is incorrectly replaced. Replace only with the same or equivalent type recommended by the manufacturer. Dispose of used batteries according to the manufacturer's instructions.	
Flash Disk	2 Megabytes
Memory	1 Megabyte max.
PiCPro Port (to workstation)	RS232 serial port, secured protocol Software selectable baud rate to 115.2K
User Port (to serial interface device)	RS232/RS485 serial port Supports RTS/CTS hardware handshaking Software selectable baud rate to 115.2K
Ethernet Port (to Ethernet Device)	IEEE 802.3/802.3u-100Base-TX/10Base T Half duplex Cable type: Shielded, Straight Pinned, CAT5 or better (CAT5e, CAT6, etc.) Maximum cable length: 82.5 ft (25 m)
Input voltage from MMC-SD Drive	20 VDC to 30 VDC
Input power from MMC-SD Drive	250 mA
Time-of-day clock Clock tolerance	Access via PiCPro 10.2 and above or your application program At 25°C (77°F), ±1 second per day Over temperature, voltage and aging variation, +2/-12 seconds per day
General DC Inputs	
Configuration	Sourcing only. Operates with IEC Type 1 inputs (per IEC 1131-2)
Input voltage	Nominal 24 VDC, maximum 30 VDC
Guaranteed on voltage	15 VDC
Guaranteed off voltage	5 VDC
Turn on/off time	1 ms

General DC Outputs	
Number of outputs	8 outputs
Input voltage	Nominal 24 VDC, 30 VDC maximum
Configuration	Eight solid-state switches.
Protection of logic circuits	Optical isolation between the logic and field side, transient suppression on the 24V external supply
Maximum current	.25 A per output
Voltage range	24 VDC nominal, 5 to 30 VDC
Switch characteristics	Solid-state switches
Time delay on for resistive loads	50 μ sec max
Time delay off for resistive loads	50 μ sec max
Leakage current in off state	0.5 mA max
Switch voltage, maximum ON	1 VDC max
Short circuit protection for each group	15 A (max) pulses for about 130 μ sec every 100 msec until short is removed
Scan loss response	Outputs turn off

14 Declarations of Conformity

EC DECLARATION OF CONFORMITY

The undersigned, representing the supplier

G & L Motion Control Inc.
672 South Military Road
Fond du Lac, Wisconsin 54936-1960

herewith declares that all **three-phase current synchronous motors, type LSM** are in conformity with the provisions of the following EC Directive when installed in accordance with the installation instructions contained in the product documentation:

Low Voltage Directive 73/23 EWG

Conformity of the specified product with the guidelines of this directive will be proved by the total compliance with the following harmonic European standards:

EN 60034-1: September 2000 Rotating Electrical Machines
+A11 May 2002
EN 60034-5: December 2001
EN 60034-9: June 1998

Year of Marking: 2002

<i>Signature</i>	<i>Robert J. Kollmeyer</i>
<i>Full Name</i>	Robert J. Kollmeyer
<i>Position</i>	Director of Engineering
<i>Place</i>	G & L Motion Control Inc.
<i>Date</i>	<i>05 - APR - 05</i>

EC DECLARATION OF CONFORMITY

The undersigned, representing the supplier

G & L Motion Control Inc.
672 South Military Road
Fond du Lac, Wisconsin 54936-1960

herewith declares that all **three-phase current synchronous motors, type MSM** are in conformity with the provisions of the following EC Directive when installed in accordance with the installation instructions contained in the product documentation:

Low Voltage Directive 73/23 EWG

Conformity of the specified product with the guidelines of this directive will be proved by the total compliance with the following harmonic European standards:

EN 60034-1: November 1995 Rotating Electrical Machines
EN 60034-5: April 1998
EN 60034-9: May 1996

Year of Marking: 1999

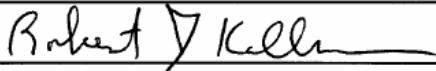
<i>Signature</i>	
<i>Full Name</i>	Robert J. Kollmeyer
<i>Position</i>	Director of Engineering
<i>Place</i>	G & L Motion Control Inc.
<i>Date</i>	05 - APR - 05

The undersigned, representing the supplier

G & L Motion Control Inc.
672 South Military Road
Fond du Lac, Wisconsin 54936-1960

herewith declares that all **PiC900™/PiC90™/PiC9™/MMC and Block I/O modules**, labeled with the CE mark, are in conformity with the provisions of the following EC Directives when installed in accordance with the installation instructions contained in the product documentation:

Low Voltage Directive 73/23/EEC as amended by 93/68/EEC
EMC Directive 89/336/EEC as amended by 92/31/EEC and 93/68/EEC

Conformity of the specified product is based upon application of the following standards and/or technical specifications referenced below:

<i>EN 50081-2:1993</i>	<i>EMC Generic Industrial Emissions</i>
<i>EN 50082-2:1995</i>	<i>EMC Generic Industrial Immunity</i>
<i>EN 61131-2:1994/A11:1996</i>	<i>Low voltage requirements for programmable controllers</i>
<i>EN61326:1997</i>	<i>Electrical Equipment for measurement, control and Laboratory use – EMC requirements</i>

Year of Marking: 2002

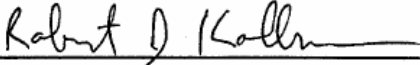
<i>Signature</i>	
<i>Full Name</i>	Robert J. Kollmeyer
<i>Position</i>	Director of Engineering
<i>Place</i>	G & L Motion Control Inc.
<i>Date</i>	05-APR-05

EC DECLARATION OF CONFORMITY

The undersigned, representing the supplier

G & L Motion Control Inc.
672 South Military Road
Fond du Lac, Wisconsin 54936-1960

herewith declares that all **servo drives and accessories** (see attached list of catalogue numbers) are in conformity with the provisions of the following EC Directive(s) when installed in accordance with the installation instructions contained in the product documentation:

Low Voltage Directive as amended by 93/68/EEC

EMC Directive as amended by 92/31/EEC and 93/68/EEC

and that the standards and/or technical specifications referenced below have been applied:

*EN 60034-1:1998 +
A1:1998 and A2:1999*

*Rotating Electrical Machines
Part 1: Rating and Performance*

EN 60204-1:1997

*Safety of machinery – Electrical equipment of machines
Part 1: Specifications for general requirements*

EN 61800-3:1996

*Adjustable Speed Electrical Power Drive Systems – EMC
Product Standard Including Specific Test Methods*

Year of Marking: 2002

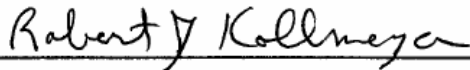
<i>Signature</i>	
<i>Full Name</i>	Robert J. Kollmeyer
<i>Position</i>	Director of Engineering
<i>Place</i>	G & L Motion Control Inc.
<i>Date</i>	05-APR-05

EC DECLARATION OF CONFORMITY

The undersigned, representing the supplier

G & L Motion Control Inc.
672 South Military Road
Fond du Lac, Wisconsin 54936-1960

herewith declares that all MMC Smart Drives (**MMC-SD-XXX-XXX-XXX**) and accessories, and all **S200-DLS Drives**, labeled with the CE mark, are in conformity with the provisions of the following EC Directive(s) when installed in accordance with the installation instructions contained in the product documentation:

73/23/EEC *Low Voltage Directive as amended by 93/68/EEC*
89/336/EEC *EMC Directive as amended by 92/31/EEC and 93/68/EEC*

and that the standards and/or technical specifications referenced below have been applied:

EN 50178:1998 *Electronic equipment for use in power installations*
EN 61800-3:1996 *Adjustable speed electrical power drive systems - EMC*
/A11:2000 *Product standard including specific test methods*

Year of Marking: 2003

Signature	
Full Name	Peter Winkelmann
Position	Business Unit Manager
Place	G & L Motion Control Inc.
Date	10 MAR 09

Appendix A- 460V MMC Smart Drive DC Bus Sharing

A.1 Introduction

This section discusses DC bus sharing among 2 or more 460V Smart Drives.

DC bus sharing accomplishes 4 things:

- It pools the capacitance of all of the drives.
- It lowers electricity cost.
- It allows multiple drives to share one shunt resistor.
- It allows the shunt energy to be shared among multiple shunt resistors.

Pooling the capacitance increases the Joule energy absorption capability to the sum of the drives connected ([Table A-2 on page 358](#)). This lowers energy cost slightly because energy that can be absorbed is not wasted in the shunt resistors. In some applications, this can eliminate the need for a shunt resistor altogether.

Many applications will have one drive motoring while the other is regenerating. This energy is transferred from one drive to the other through the DC bus rather than being dissipated in a shunt. This saves energy cost.

If it is desired to share one shunt resistor instead of using one per drive, the energy flows through the DC bus to the drive controlling the shunt resistor. Its internal circuitry will turn the shunt on when the bus voltage reaches an upper limit.

If it is desired to distribute the shunt load among multiple drives, each having a smaller resistor, then **it is important to interconnect the “Shunt On” signals for all drives sharing the DC bus**. This ensures that all of the shunt resistors will properly share the load. If this connection is not made, it is likely that only one shunt resistor will dissipate all of the shunt power, overheating it.

A.2 DC Bus Sharing with AC Power to All Drives

When sharing DC power among several drives with AC power supplying all of the drives ([Figure A-1](#)), all drives must be the same size (for example, all drives must be MMC-SD-4.0-460). When two drives are connected to a shared DC bus in this manner, the combined energy absorption of all drives is available.

3% line reactors are required for all sizes using this configuration to ensure rectifier balance. However, shunt resistors are optional (see below). Refer to Chapter 4 in this manual for information related to fusing, line reactors and shunts. Refer to Chapter 6 for connector information.

When more than one shunt is used with the MMC Smart Drives, it is important to tie the “Shunt On” circuits together so that all shunts get turned on at the same time. For example, in [Figure A-1](#), if the shunt connected to Drive 1 turns on, the “Shunt On” signal will turn on the shunt for Drive 2. The second shunt resistor is optional as long as the “Shunt On” signal is connected as shown. The “Shunt On” signal acts as both an input and an output for each Drive.

Figure A-1: DC Bus Sharing with AC Input Power to All Drives

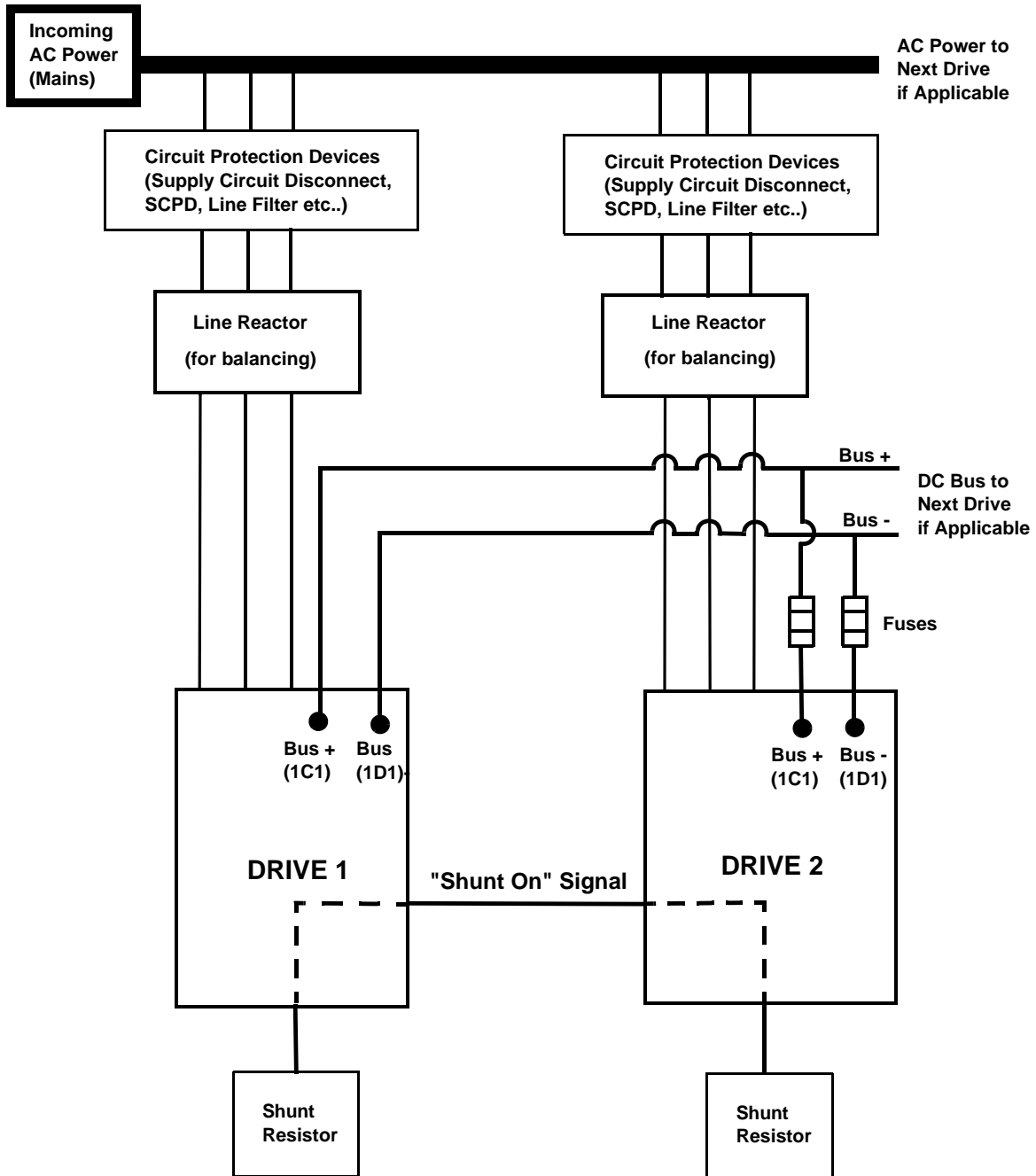

A.3 DC Bus Sharing with AC Power to One Drive

When sharing DC power among several drives with AC power supplying just one of the drives ([Figure A-2](#)), all drives need not be the same size (for example, one drive may be a MMC-SD-8.0-460, and another drive may be a MMC-SD-1.3-

460). When two or more drives are connected to a shared DC bus in this manner, there are two limits that must be considered:

- The drives not powered by AC must not consume more power than the “Bus power available for linking to other drives” as listed in [Table A-1](#).
- The total power consumed by all drives cannot exceed the greater of “Bus power available for linking to other drives” and the kW rating of the AC powered drive as listed in [Table A-1](#).

For example, assume that the AC powered drive is a MMC-SD-24.0-460 and consumes 14kW, and supplies DC power to two more drives that consume 4kW each (8kW total). From [Table A-1](#), the total DC power available to the non-AC powered drives is 10kW, meeting the first criteria. The total power consumed is 22kW, and since the AC powered drive is a 24kW drive, meets the second criteria.

The continuous current available from the drive would be reduced by the same percentage as the kW. In the example given, the available kW was reduced from 24 to 16kW. Therefore $16/24 = 67\%$. The drive’s continuous current is reduced by 1/3 from 45 Amps to 30 Amps.

If peak current is to be used at the same time on more than one drive, the total peak current used by all drives must not exceed that of the main drive. If both the main and auxiliary drives will accelerate at the same time, the peak current used by auxiliary drives is subtracted from the available peak current of the main drive. Connection of a shunt to the main drive is optional depending on the results found in sizing the system. The system will have the combined DC Bus capacitance of all drives connected.

[Table A-2 on page 358](#) shows the MMC Smart Drive bus capacitance and energy absorption capability.

:

Table A-1: kW Ratings for Powered Drive			
Drive Model	Bus power available for linking to other drives	Continuous Current (Amps)	Peak Current (Amps)
MMC-SD-1.3-460	2.0kW	3	6
MMC-SD-2.4-460	2.0kW	5.5	11
MMC-SD-4.0-460	5.0kW	9	18
MMC-SD-6.0-460	5.0kW	13.5	27
MMC-SD-8.0-460	5.0kW	18	36
MMC-SD-12.0-460	10.0kW	27.5	55
MMC-SD-16.0-460	10.0kW	36.5	73
MMC-SD-24.0-460	10.0kW	55	110
MMC-SD-30.0-460	10.0kW	69.3	110
MMC-SD-42.0-460	36.0kW	93.3	147
MMC-SD-51.0-460	45.0kW	117.4	184
MMC-SD-65.0-460	58.0kW	152.7	209

Figure A-2: Two or more drives with AC input power to one drive

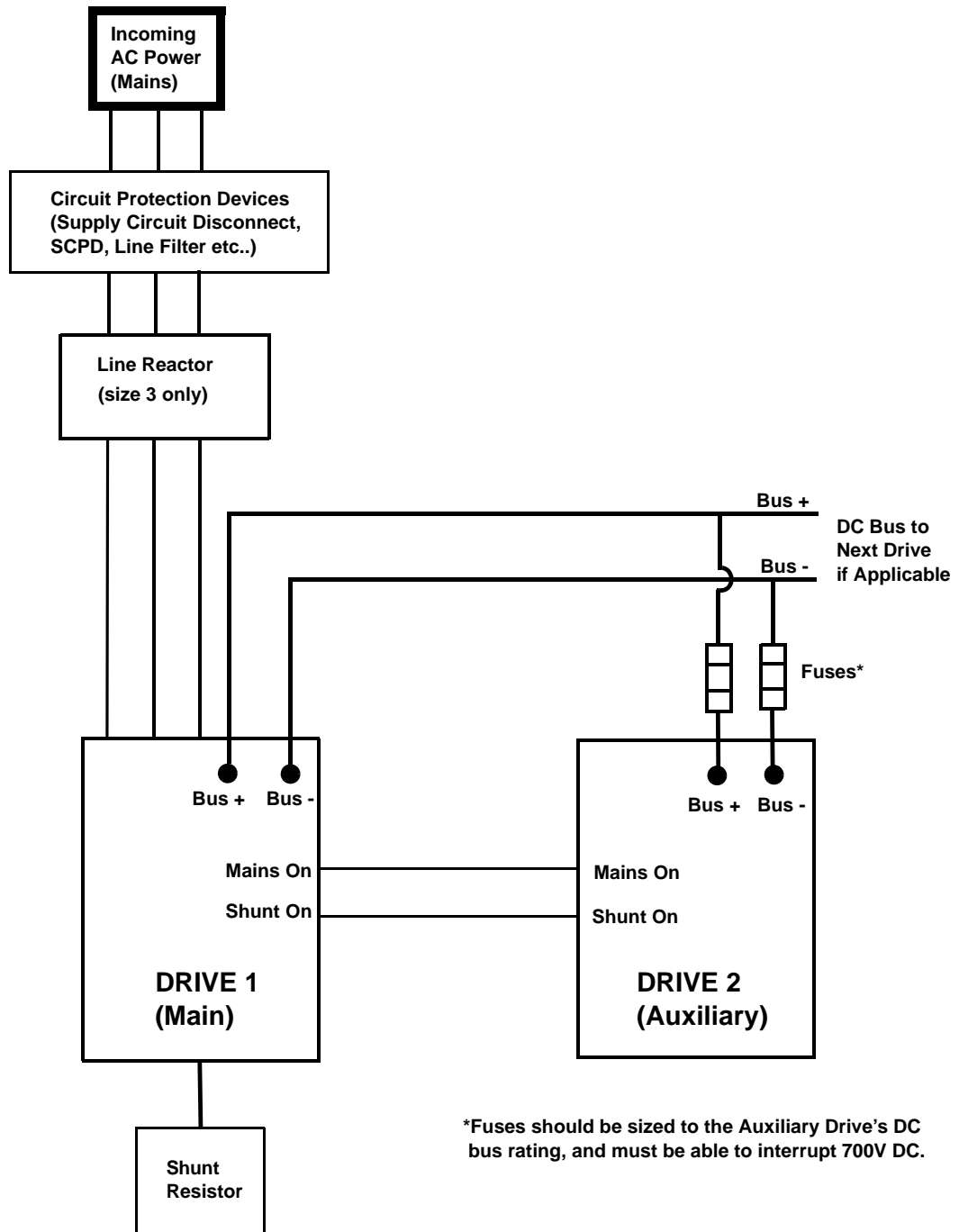

Table A-2: Drive Bus Capacitance and energy Absorption Capability

Drive ^a	MMC Smart Drive Bus Capacitance (μFarad)	Energy Absorption at 230V Line Input and 230V Motor (Joules)	Energy Absorption at 230V Line Input and 460V Motor (Joules)	Energy Absorption at 460V Line Input and 460V Motor (Joules)
460V Size 1				
MMC-SD-1.3-460	110	3	28	10
MMC-SD-2.4-460	240	7	60	22
460V Size 2				
MMC-SD-4.0-460	470	13	118	44
MMC-SD-6.0-460	470	13	118	44
MMC-SD-8.0-460	705	19	177	66
460V Size 3				
MMC-SD-12.0-460	820	22	206	76
MMC-SD-16.0-460	1230	33	309	114
MMC-SD-24.0-460	1640	45	412	152
MMC-SD-30.0-460	2000	55	502	185
460V Size 4				
MMC-SD-42.0-460	1880	50.4	472	173
MMC-SD-51.0-460	2350	63.1	591	218
MMC-SD-65.0-460	3055	82	768	284
230 V^b				
MMC-SD-0.5-460	1410	38		
MMC-SD-1.0-460	1880	51		
MMC-SD-2.0-460	1880	51		

a. add suffix (-D) for Digital Drive

b. add suffix (-D) for Digital Drives and (-DN) for Digital Narrow Drives

Index

Numerics

230V Smart Drive [161](#)

24VDC IN/Brake connector [202](#)

address switches [169](#), [170](#)

dimensions [213](#)

drive I/O connector [194](#)

F1/F2 feedback connectors [172](#)

LEDs [164](#)

motor connector [204](#)

PiCPro port (analog drive) [166](#)

PiCPro port (digital drive) [164](#)

power connector [204](#)

regen connector [207](#)

specifications [208](#)

230V Smart Drive NextGen [77](#)

AC power connector [103](#)

address switches [80](#)

bus/regen connector [107](#)

DC power connector [102](#)

digital link port [81](#)

dimensions [115](#)

drive I/O connector [98](#)

F1/F2 feedback connectors [83](#)

feedback cables [93](#)

motor chokes [106](#)

motor feedback cables [93](#)

motor/brake cables [106](#)

motor/brake connector [104](#)

safe-off [102](#)

specifications [109](#)

status display [80](#)

24V power connector

460V Smart Drive

size 1 [224](#)

size 2 [229](#)

size 3 [234](#)

size 4 [239](#)

24VDC IN/Brake connector

230V Smart Drive [202](#)

460V Smart Drive

24V power connector

size 1 [224](#)

size 2 [229](#)

size 3 [234](#)

size 4 [239](#)

AC power connector

size 1 [223](#)

size 2 [227](#)

size 3 [232](#)

size 4 [237](#)

address switches [169](#), [170](#)

connectors

size 1 [220](#)

size 2 [225](#)

size 3 [230](#)

size 4 [235](#)

dimensions [257](#)

drive connection layout [242](#)

drive I/O connector [194](#)

F1/F2 feedback connectors [172](#)

fan connector

size 4 [241](#)

motor brake connector

size 1 [225](#)

size 2 [230](#)

size 3 [235](#)

size 4 [240](#)

motor connector

size 1 [223](#)

size 2 [228](#)

size 3 [233](#)

size 4 [238](#)

PiCPro port (analog drive) [166](#)

PiCPro port (digital drive) [164](#)

shunt/DC bus connector

size 1 [222](#)

specifications [243](#)

460V Smart Drive NextGen [119](#)

AC power connector [145](#)

address switches [122](#)

bus/regen connector [149](#)

DC power connector [144](#)

digital link port [123](#)

dimensions [157](#)

drive I/O connector [140](#)

F1/F2 feedback connectors [125](#)

feedback cables [135](#)

fuses & holders [146](#)

motor chokes [148](#)

motor feedback cables [135](#)

motor/brake cables [148](#)

motor/brake connector [146](#)

safe-off [144](#)

specifications [151](#)

status display [122](#)

7-segment display

troubleshooting with [299](#)

A

AC power connector

230V Smart Drive NextGen [103](#)

460V Smart Drive

size 1 [223](#)

size 2 [227](#)

size 3 [232](#)

- size 4 [237](#)
- 460V Smart Drive NextGen [145](#)
- address switches
 - 230V Smart Drive [169](#), [170](#)
 - 230V Smart Drive NextGen [80](#)
 - 460V Smart Drive [169](#), [170](#)
 - 460V Smart Drive NextGen [122](#)
 - S200-DLS Drive [268](#)

- AKM/DDR motors
 - F1/F2 encoder cable [186](#)
 - F1/F2 Endat/BiSS cable [182](#)
 - F1/F2 resolver cable [184](#)
 - power cables [290](#)

- application
 - wiring [27](#)
- Auxiliary Feedback Port
 - S200-DLS Drive [271](#)

B

- bending radius
 - cable [287](#)
- block I/O port
 - Drive Resident MMC Control [323](#)
- bonding
 - mounting [22](#)
- bus/regen connector
 - 230V Smart Drive NextGen [107](#)
 - 460V Smart Drive NextGen [149](#)

C

- cable
 - bending radius [287](#)
 - F1/F2 encoder to AKM/DDR motor [186](#)
 - F1/F2 encoder to FSM motor [190](#)
 - F1/F2 encoder to LSM/MSM motor [188](#)
 - F1/F2 encoder to YSM motor [192](#)
 - F1/F2 Endat/BiSS to AKM/DDR motor [182](#)
 - F1/F2 resolver to AKM/DDR motor [184](#)
 - flex cable installation [288](#)
 - tension [288](#)
- CE
 - filter requirements [26](#)
- combination fuse
 - part numbers [48](#), [49](#)
- conformity
 - european directives [20](#)
 - UL and cUL standards [20](#)
- connecting
 - Drive Resident MMC Control [319](#)
- connections
 - Drive Resident MMC Control [323](#)
- connector kits
 - LSM/MSM motors [291](#)

- connectors
 - 460V Smart Drive
 - size 1 [220](#)
 - size 2 [225](#)
 - size 3 [230](#)
 - size 4 [235](#)
- contents of the manual [9](#)
- control cabinet
 - requirements [23](#)

D

- DC input operation
 - Drive Resident MMC Control [342](#)
- DC output operation
 - Drive Resident MMC Control [340](#)
- DC power connector
 - 230V Smart Drive NextGen [102](#)
 - 460V Smart Drive NextGen [144](#)
- diagnostic
 - error codes [299](#), [307](#)
- Diagnostic Indicator
 - S200-DLS Drive [267](#)
- diagnostic LED
 - troubleshooting with [299](#)
- diagnostics
 - Drive Resident MMC Control [320](#)
 - power on [298](#)
 - run-time [298](#)
- Digital Link
 - LEDs [267](#)
- digital link option card
 - S200-DLS Drive [267](#)
- digital link port
 - 230V Smart Drive NextGen [81](#)
 - 460V Smart Drive NextGen [123](#)
- Digital Link Ports
 - S200-DLS Drive [269](#)
- dimensions
 - 230V Smart Drive [213](#)
 - 230V Smart Drive NextGen [115](#)
 - 460V Smart Drive [257](#)
 - 460V Smart Drive NextGen [157](#)
 - cabinet clearance [21](#)
 - motor cable [33](#)
- distribution
 - power [30](#)
- drive connection layout
 - 460V Smart Drive [242](#)
- drive I/O connector
 - 230V Smart Drive [194](#)
 - 230V Smart Drive NextGen [98](#)
 - 460V Smart Drive [194](#)
 - 460V Smart Drive NextGen [140](#)
- Drive I/O Port details

- S200-DLS Drive [279](#)
- Drive Resident MMC Control
 - block I/O port [323](#)
 - connecting [319](#)
 - connections [323](#)
 - DC input operation [342](#)
 - DC output operation [340](#)
 - diagnostics [320](#)
 - error codes [322](#)
 - ethernet port [333](#)
 - front view [316](#)
 - general I/O port [335](#)
 - overview [315](#)
 - PiCPro port [323](#)
 - power LED [320](#)
 - run-time diagnostics [322](#)
 - scan LED [320](#)
 - setup and maintenance [319](#)
 - specifications [344](#)
 - starting an operation [319](#)
 - startup diagnostic LED [321](#)
 - system wiring guidelines [318](#)
 - troubleshooting [320](#)
 - user port [327](#)

E

- electrical service & maintenance safety [16](#)
- EMI (ElectroMagnetic Interference)
 - bonding [22](#)
- error codes
 - diagnostic [299](#), [307](#)
 - drive fault [301](#), [307](#)
 - Drive Resident MMC Control [322](#)
- ethernet port
 - Drive Resident MMC Control [333](#)

F

- F1/F2 feedback connectors
 - 230V Smart Drive [172](#)
 - 230V Smart Drive NextGen [83](#)
 - 460V Smart Drive [172](#)
 - 460V Smart Drive NextGen [125](#)
- fan cables
 - LSM/MSM motors [295](#)
- fan connector
 - 460V Smart Drive
 - size 4 [241](#)
- faults
 - diagnostic [299](#), [307](#)
- feedback cables
 - 230V Smart Drive NextGen [93](#)
 - 460V Smart Drive NextGen [135](#)
- filter, AC power [26](#)

- flex cable
 - installation [288](#)
 - installation guidelines [287](#)
- front view
 - Drive Resident MMC Control [316](#)
- FSM motors
 - F1/F2 encoder cable [190](#)
- fuses & holders
 - 460V Smart Drive NextGen [146](#)

G

- general I/O port
 - Drive Resident MMC Control [335](#)
- grounding
 - CE single phase 230V drive system [26](#)
 - multiple drives [27](#)
 - protective earth [14](#)
 - system [24](#)

H

- handling the MMC Smart Drive [19](#)
- heat
 - controlling [21](#)

I

- I/O Power Port
 - S200-DLS Drive [279](#)
- inspection
 - safety [15](#)
- installation [20](#)
- installation guidelines
 - flex cables [287](#)
- installing [19](#)
 - resolver option module [311](#)
- isolation transformers
 - 230V formula [58](#)
 - 460V formula [58](#)

L

- LEDs
 - 230V Smart Drive [164](#)
 - Digital Link on S200-DLS Drive [267](#)
 - error codes [307](#)
 - S200-DLS drive option card [267](#)
- line filters
 - block diagram for 3-phase [69](#)
 - CE compliance [69](#)
 - connection diagram for 3-phase [70](#)
 - technical data
 - 230V [72](#)
 - 460V [73](#)
- LSM/MSM motors
 - connector kits [291](#)

- F1/F2 encoder cable [188](#)
- fan cables [295](#)
- power cables [292](#)

M

- maintenance [297](#)
- manual cleaning procedure [17](#)
- MMC Control
 - see Drive Resident MMC Control [315](#)
- MMC Smart Drive
 - introduction [161](#), [219](#)
 - power [31](#)
- motor brake connector
 - 460V Smart Drive
 - size 1 [225](#)
 - size 2 [230](#)
 - size 3 [235](#)
 - size 4 [240](#)
- motor cables [287](#)
- motor chokes
 - 230V Smart Drive NextGen [106](#)
 - 460V Smart Drive NextGen [148](#)
- motor connector
 - 230V Smart Drive [204](#)
 - 460V Smart Drive
 - size 1 [223](#)
 - size 2 [228](#)
 - size 3 [233](#)
 - size 4 [238](#)
- motor feedback cables
 - 230V Smart Drive NextGen [93](#)
 - 460V Smart Drive NextGen [135](#)
- motor/brake cables
 - 230V Smart Drive NextGen [106](#)
 - 460V Smart Drive NextGen [148](#)
- motor/brake connector
 - 230V Smart Drive NextGen [104](#)
 - 460V Smart Drive NextGen [146](#)
- mounting [23](#)
 - bonding [22](#)

N

- noise
 - see bonding [22](#)

O

- operation
 - safety [16](#)
- overview
 - Drive Resident MMC Control [315](#)

P

- part numbers

- combination fuse [48](#), [49](#)
- PicPro port
 - Drive Resident MMC Control [323](#)
- PiCPro port (analog drive)
 - 230V Smart Drive [166](#)
 - 460V Smart Drive [166](#)
- PiCPro port (digital drive)
 - 230V Smart Drive [164](#)
 - 460V Smart Drive [164](#)
- power
 - distribution in MMC [30](#)
 - MMC Smart Drive [31](#)
- power cables
 - AKM/DDR motors [290](#)
 - LSM/MSM motors [292](#)
- power connector
 - 230V Smart Drive [204](#)
- power LED [298](#)
 - Drive Resident MMC Control [320](#)
- power-on diagnostics [298](#)
- procedure
 - manual cleaning [17](#)
- protective earth
 - grounding [14](#)

R

- regen connector
 - 230V Smart Drive [207](#)
- Requirements
 - Transformer [38](#), [39](#)
- resolver option module
 - installing [311](#)
 - theory of operation [311](#)
- run-time diagnostics [298](#)
 - Drive Resident MMC Control [322](#)

S

- S200-DLS Drive
 - address switches [268](#)
 - Auxiliary Feedback Port [271](#)
 - Diagnostic Indicator [267](#)
 - Digital Link Option Card [267](#)
 - Digital Link Ports [269](#)
 - Drive I/O Port details [279](#)
 - I/O Power Port details [279](#)
 - introduction [265](#)
 - LEDs [267](#)
 - specifications [285](#)
- safe-off
 - 230V Smart Drive NextGen [102](#)
 - 460V Smart Drive NextGen [144](#)
- safe-off on 230V Drives
 - operation on non-Safe-off Drives [204](#)

- operation on Safe-off Drives [203](#)
- signal requirements [203](#)
- safety
 - after shutdown [15](#)
 - cleaning [17](#)
 - electrical service & maintenance [16](#)
 - inspection [15](#)
 - operating safely [16](#)
 - operation [16](#)
 - signs [14](#)
 - system [13](#)
 - warning labels [14](#)
- Sales and Service [365](#)
- scan LED
 - Drive Resident MMC Control [320](#)
- Service [365](#)
- setup and maintenance
 - Drive Resident MMC Control [319](#)
- shields [28](#)
- shunt modules
 - connecting [61](#), [66](#)
- shunt/DC bus connector
 - 460V Smart Drive
 - size 1 [222](#)
- shunts [58](#)
 - choosing [58](#)
- signs
 - safety [14](#)
- single point ground (SPG)
 - checklist [24](#)
- software
 - required [9](#)
- specifications
 - 230V Smart Drive [208](#)
 - 230V Smart Drive NextGen [109](#)
 - 460V Smart Drive [243](#)
 - 460V Smart Drive NextGen [151](#)
 - Drive Resident MMC Control [344](#)
 - optional resolver module [314](#)
 - S200-DLS Drive [285](#)
- starting an operation
 - Drive Resident MMC Control [319](#)
- startup diagnostic LED
 - Drive Resident MMC Control [321](#)
- status display
 - 230V Smart Drive NextGen [80](#)
 - 460V Smart Drive NextGen [122](#)
- storage
 - before installation [19](#)
- storing the drive [19](#)

- system mounting requirements
 - ventilation [20](#)
- system wiring guidelines
 - Drive Resident MMC Control [318](#)

T

- technical support contacts [11](#)
- tension
 - cable [288](#)
- theory of operation
 - resolver option module [311](#)
- Transformer
 - Size [38](#), [39](#)
- troubleshootig
 - with 7-segment display [299](#)
 - with diagnostic LED [299](#)
- troubleshooting
 - drive error codes [301](#), [307](#)
 - Drive Resident MMC Control [320](#)
 - general [298](#)

U

- Unpacking [19](#)
- user port
 - Drive Resident MMC Control [327](#)

V

- ventilation [20](#)

W

- warning label
 - danger, warning, caution [15](#)
 - hazard [14](#)
- Web Address [365](#)
- wiring
 - application [27](#)
 - connecting shunt modules [61](#), [66](#)
 - connections for 3-phase line filter [70](#)
 - EMC compliant [27](#)
 - interface cables [32](#)
 - preparing motor connection wires [33](#)
 - routing high/low voltage cables [32](#)
 - terminating 230V motor power cable [34](#), [36](#)
 - terminating 460V power cable [35](#)

Y

- YSM motors
 - F1/F2 encoder cable [192](#)

Sales and Service

We are committed to quality customer service. In order to serve in the most effective way, please contact your local sales representative for assistance.

If you are unaware of your local sales representative, please contact us.

North America

Kollmorgen Customer Support North America

E-mail: glmotion.support@kollmorgen.com
Phone: In the United States, telephone (800) 558-4808
Outside the United States, telephone (920) 921-7100
Fax: (920) 906-7669
Web site: www.kollmorgen.com

Europe

Kollmorgen Customer Support Europe

E-mail: glmotion.support@kollmorgen.com
Phone: +44 (0)1525 243-243
Fax: +44 (0)1525 243-244
Web site: www.kollmorgen.com

KOLLMORGEN®

Because Motion Matters™

