

Synchronous Servomotors

Series 6SM45...100



Technical description, Installation, Commissioning

Edition 07/06

Already published editions

Edition	Comment
07 / 93	First edition
10 / 94	Adaptation to modified technical design, layout and page numbering changed
05 / 96	New motors 6SM27 / 6SM37 / 6SM100
05 / 97	New motors 6SMx7, 6SM109, several corrections
03 / 98	6SM27..77/109 removed
05 / 00	Enhanced torque characteristics, new layout, corrections
09 / 05	Short fan covers removed, design, brand
07 / 06	Cable bushing metric, cable data

**Technical changes to improve the performance of the equipment
may be made without prior notice!**

All rights reserved. No part of this work may be reproduced in any form (by printing, photocopying, microfilm or any other method) or stored, processed, copied or distributed by electronic means without the written permission of Danaher Motion.

1	General	
1.1	About this manual	5
1.2	Prescribed usage	5
1.3	Safety Notes	6
1.4	Important Notes	7
1.5	Warning signs used in this manual	7
1.6	Manufacturer declaration	8
1.7	Design of the motors	9
1.8	General technical data	9
1.9	Standard features	10
1.9.1	Style	10
1.9.2	Shaft end, A-side	10
1.9.3	Flange	10
1.9.4	Protection class	10
1.9.5	Protective device	10
1.9.6	Insulation material class	11
1.9.7	Vibration class	11
1.9.8	Connection method	11
1.9.9	Resolver	11
1.9.10	Holding brake	11
1.10	Selection criteria	11
1.11	Options	12
1.12	Nameplate	12
1.13	Technical data	13
1.13.1	Definitions	13
1.13.2	Technical data 6SM45..100	14
1.13.3	Technical data 6SM56..100-BV	15
2	Installation / Commissioning	
2.1	Important notes	17
2.2	Assembly / Wiring	18
2.2.1	Connection methods	20
2.3	Commissioning	21

3	Drawings	
3.1	Non-ventilated motors	23
3.1.1	Dimensions 6SM45..100	23
3.1.2	Radial-/axial force at the shaft end	23
3.1.3	Wiring diagram 6SM45..100	24
3.1.4	Torque characteristics 6SM45S-3000	25
3.1.5	Torque characteristics 6SM45M-3000	25
3.1.6	Torque characteristics 6SM45L-3000	26
3.1.7	Torque characteristics 6SM56S-3000	26
3.1.8	Torque characteristics 6SM56M-3000	27
3.1.9	Torque characteristics 6SM56L-3000	27
3.1.10	Torque characteristics 6SM71K-3000	28
3.1.11	Torque characteristics 6SM71S-3000	28
3.1.12	Torque characteristics 6SM71M-3000	29
3.1.13	Torque characteristics 6SM100K-3000	29
3.1.14	Torque characteristics 6SM100S-3000	30
3.1.15	Torque characteristics 6SM100M-3000	30
3.1.16	Torque characteristics 6SM100L-3000	31
3.2	Ventilated motors	32
3.2.1	Dimensions 6SM56..100-BV	32
3.2.2	Radial-/axial force at the shaft end	32
3.2.3	Wiring diagram 6SM56..100-BV	33
3.2.4	Fan connection	34
3.2.5	Torque characteristics 6SM56S-3000-BV	35
3.2.6	Torque characteristics 6SM56M-3000-BV	35
3.2.7	Torque characteristics 6SM56L-3000-BV	36
3.2.8	Torque characteristics 6SM71K-3000-BV	36
3.2.9	Torque characteristics 6SM71S-3000-BV	37
3.2.10	Torque characteristics 6SM71M-3000-BV	37
3.2.11	Torque characteristics 6SM100K-3000-BV	38
3.2.12	Torque characteristics 6SM100S-3000-BV	38
3.2.13	Torque characteristics 6SM100M-3000-BV	39
3.2.14	Torque characteristics 6SM100L-3000-BV	39
4	Appendix	
4.1	Delivery package, transport, storage, maintenance, disposal	41
4.2	Fault-finding	42
4.3	Index	43

1 General

1.1 About this manual

This manual describes the 6SM45..100 series of synchronous servomotors (standard version). Among other things, you find information about:

- Description of the Motors, Technical Data Chapter 1
- Installation, Commissioning of the motors Chapter 2
- Dimensions, wiring and characteristics Chapter 3
- Notes on Transport, Storage, Maintenance, Disposal Chapter 4



This Manual is intended for the use of qualified staff with professional knowledge of electrical and mechanical engineering.

The motors are operated in drive systems together with servo amplifiers SERVOSTAR. Please observe the entire system documentation, consisting of:

- Installation and commissioning instructions for the servo amplifier
- Installation and commissioning instructions for any CONNECT module or expansion card which is connected
- Operating manual for the Operator Software of the servo amplifier
- Technical description of the 6SM45..100 series of motors

1.2 Prescribed usage

The 6SM45..100 series of synchronous servomotors is designed especially for drives for industrial robots, machine tools, textile and packing machinery and similar with high requirements for dynamics.

The user is **only** permitted to operate the motors under the ambient conditions which are defined in this documentation.

The 6SM45..100 series of motors is **exclusively** intended to be driven by servo amplifiers from the SERVOSTAR series under speed and / or torque control.

The mains supply voltage of the used servo amplifier must not exceed 400V at 50..60Hz, TN-system or TT-system with earthed neutral point.

The motors are installed as components in electrical apparatus or machines and can only be commissioned and put into operation as integral components of such apparatus or machines.

The motors must never be connected directly to the mains supply.

The thermal contact which is integrated in the motor windings must be observed and evaluated.

The conformity of the servo-system to the standards mentioned in the manufacturers declaration on page is only guaranteed when the components (servo amplifier, motor, cables etc.) that are used have been supplied by us.

1.3

Safety Notes

- Only properly qualified personnel are permitted to perform such tasks as transport, assembly, commissioning and maintenance. Properly qualified personnel are persons who are familiar with the transport, assembly, installation, commissioning and operation of motors, and who have the appropriate qualifications for their jobs. The qualified personnel must know and observe the following standards and regulations:
IEC 364 resp. CENELEC HD 384 or DIN VDE 0100
IEC-report 664 or DIN VDE 0110
national regulations for safety and accident prevention or BGV A3
- Read the available documentation before assembly and commissioning. Incorrect handling of the motors can result in injury and damage to persons and machinery. Keep strictly to the technical data and the information on the connection requirements (nameplate and documentation).
- It is vital that you ensure that the motor housing is safely earthed to the PE (protective earth) busbar in the switch cabinet. Electrical safety is impossible without a low-resistance earth connection.
- Never open the motor terminal box during operation. Do not unplug any connectors during operation. This creates the danger of death, severe injury, or extensive material damage.
- Power connections may be live even when the motor is not rotating. Never disconnect the power connections of the motor while the equipment is energised. This can cause flashovers with resulting injuries to persons and damage to the contacts.
- After disconnecting the servo amplifier from the supply voltage, wait at least five minutes before touching any components which are normally live (e.g. contacts, screw connections) or opening any connections.
The capacitors in the servo amplifier can still carry a dangerous voltage up to five minutes after switching off the supply voltages. To be quite safe, measure the DC-link voltage and wait until the voltage has fallen below 40V.
- The surfaces of the motors can be very hot in operation, according to their protection category. The surface temperature can reach 100°C. Measure the temperature, and wait until the motor has cooled down below 40°C before touching it.

1.4

Important Notes

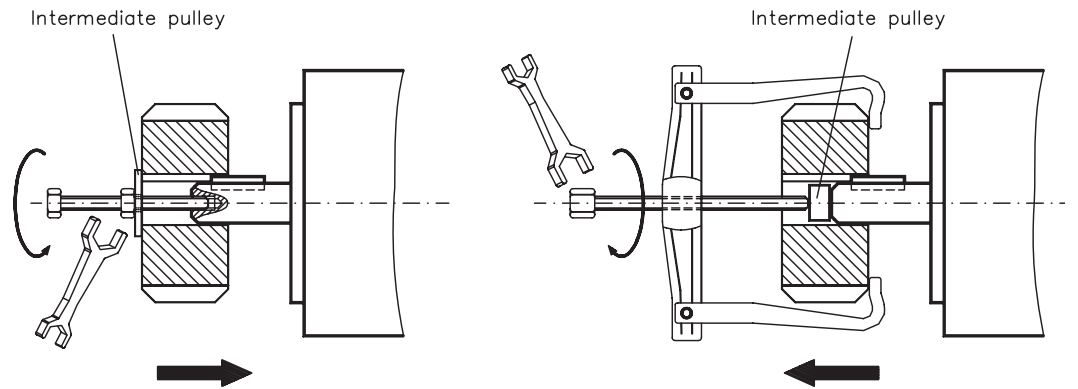

- Servomotors are precision equipment. The flange and shaft are especially vulnerable during storage and assembly — so avoid brute force. Precision requires delicacy. It is important to use the locking thread which is provided to tighten up couplings, gear wheels or pulley wheels and warm up the drive components, where possible. Blows or the use of force will lead to damage to the bearings and the shaft.



- Wherever possible, use only backlash-free, frictionally-locking collets or couplings, e.g. from the manufacturers Baumann & Cie, Gerwah, Jacob, KTR or Ringspann. Ensure correct alignment of the couplings. A displacement will cause unacceptable vibration and the destruction of the bearings and the coupling.
- For toothed belts, it is vital to observe the permissible radial forces. An excessive radial load on the shaft will significantly shorten the life of the motor.
- Avoid axial loads on the motor shaft, as far as possible. Axial loading significantly shortens the life of the motor.
- In all cases, do not create a mechanically constrained motor shaft mounting by using a rigid coupling with additional external bearings (e.g. in a gearbox).
- For mounting style V3 (shaft end upwards), make sure that no liquid can enter the upper bearing.
- Take note of the no. of motor poles and the no. of resolver poles, and ensure that the correct setting is made in the servo amplifier which is used. An incorrect setting can lead to the destruction of the motor, especially with small motors.

1.5

Warning signs used in this manual

	Danger to personnel from electricity and its effects		General warning general instruction mechanical hazard
⇒	see page/chapter (cross reference)	●	special emphasis

1.6 Manufacturer declaration

According to the EG-Machine-guideline 89/392/EWG, appendix II B

We, the company

Danaher Motion GmbH
Wacholderstraße 40-42
40489 Düsseldorf

declare, that the product

**Motor series 6SM
(types 6SM45, 6SM56, 6SM71, 6SM100)**

is intended exclusively, in its standard version, for installation in another machine and that its commissioning is forbidden until it has been established that the machine into which this product is to be installed conforms to the provisions of the EC Directive in its version 89/392/EEC.

We confirm that the above-mentioned product conforms to the following standards:

73/23/EWG	Low voltage directive
VDE 0530 / DIN 57530	Provisions for rotating machinery
DIN EN 60034-7	Design
DIN 748	Cylindrical shaft ends
DIN 6885	Keys / keyways
DIN 42955	True running, coaxiality and concentricity
DIN EN 60034-14	Vibration class

Issued by: Management

Michel van Roozendaal

This Declaration does not contain any assurance of properties. The notes on safety and protection in the operating instructions must always be observed.

1.7 Design of the motors

Synchronous servomotors in the 6SM45..100 series are brushless DC motors for demanding servo applications. When combined with our digital servo amplifiers they are especially suited for positioning tasks in industrial robots, machine tools, transfer lines etc. With high requirements for dynamics and stability.

The servomotors have permanent magnets in the rotor. The rare earth neodymium-iron-boron magnetic material is an important factor in making it possible to drive these motors in a highly dynamic fashion. A three-phase winding which is driven by the servo amplifier is integrated into the stator. The motor does not have any brushes since commutation is performed electronically by the servo amplifier.

For these motors, forced ventilation is usually not necessary, because of the optimised heat transfer through the strongly ribbed motor housing. However, in order to increase M_0 , the motors in the series 6SM56..100 can be delivered with a separately driven fan (motor plus option -BV-). The fan can also be retrofitted.

The temperature of the winding is monitored by temperature sensors in the stator windings and is signalled via an electrically isolated contact (normally closed).

A **resolver** is built into the motors as feedback element. The servo amplifiers of the SERVOSTAR® series evaluate the resolver (hence rotor) position and supply sinusoidal currents to the motors.

The motors can be delivered with or without a built-in holding brake.

The motors are enamelled in matt black (RAL 9005). This finish is not resistant against solvents (e.g. trichlorethylene, nitro-thinners, or similar).

1.8 General technical data

Climate category	3K3 to EN 50178
Ambient temperature (at rated values)	5...+40°C for site altitude up to 1000m amsl It is vital to consult our applications department for ambient temperatures above 40°C and encapsulated mounting of the motors.
Permissible humidity (at rated values)	85% rel. humidity, no condensation
Power derating (currents and torques)	1% / K in range 40°C...50°C up to 1000m amsl for site altitude above 1000m amsl and 40°C 6% up to 2000m amsl 17% up to 3000m amsl 30% up to 4000m amsl 55% up to 5000m amsl No derating for site altitudes above 1000m amsl with temperature reduction of 10K / 1000m
Max. permissible flange temperature	65°C ± 10% at rated values
Ball-bearing life	≥ 20.000 operating hours
Technical data	⇒ p.13
Storage data	⇒p.41

1.9 Standard features

1.9.1 Style

The basic style for the 6SM45..100 synchronous motors is style IM B5 according to DIN EN 60034-7. The permitted mounting positions may be read from the technical data of the motor series.

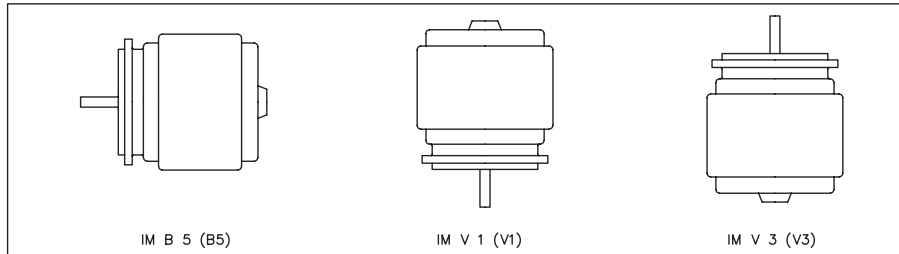

1.9.2 Shaft end, A-side

Power transmission is made through the cylindrical shaft end A (fit k6) to DIN 748, with a locking thread but **without a fitted-keyway**.

If the motors drive via pinions or toothed belts, then high radial forces will occur. The permissible values at the end of the shaft may be read from the diagram in chapter 3.1.2. The maximum values at rated speed you will find at the technical data. Power take-off from the middle of the free end of the shaft allows a 10% increase in F_R .

The curves are based on a bearing life of 20.000 operating hours.

The axial force F_A must not exceed $F_R/3$.

Double-coned collets have proved to be ideal zero-backlash coupling devices, combined, if required, with metal bellows couplings.

1.9.3 Flange

Flange dimensions to IEC standard, fit j6, accuracy according to DIN 42955. Tolerance class: **N** (R available as option -65-)

1.9.4 Protection class

Standard version	IP65
Motors with separate fan (Option -BV-)	IP54
Standard shaft bushing	IP64
Shaft bushing with shaft-sealing ring (Option -J-)	IP65

1.9.5 Protective device

The standard version of each motor is fitted with a thermostat (electrically isolated, normally closed). You will find the switching point at the technical data. The thermostat does **not** provide any protection against short, heavy overloading. Provided that our pre-assembled resolver cable is used, the thermostat contact is integrated into the monitoring system of the digital servo amplifier **SERVOSTAR®**.

The flange temperature must not exceed 65°C in rated operation.

1.9.6 Insulation material class

The motors come up to insulation material class F according to DIN 57530.

1.9.7 Vibration class

The motors are made to vibration class N according to DIN EN 60034-14.

1.9.8 Connection method

The motors are fitted with rectangular connectors for resolver signals and terminal boxes for the power supply. The mating connectors are not part of the delivery package. We can supply preassembled resolver and power cables (\Rightarrow 2.2.1).

1.9.9 Resolver

The motors are equipped with two-pole hollow-shaft resolvers.

1.9.10 Holding brake

The motors are optionally available with a holding brake.

Type designation: 6SMxxx-xxxx-**G**

A permanent magnet brake (24V DC) is integrated into the G-motors. When this brake is de-energized it blocks the rotor. **The holding brakes are designed as standstill brakes** and are not suited for repeated operational braking. If the brake is released then the rotor can be moved without a remanent torque, the operation is free from backlash!

The holding brake can be controlled directly by SERVOSTAR[®]-servo amplifier (no personal safety !), the winding is suppressed in the servo amplifier — additional circuitry is not required.

If the holding brake is not controlled directly by the servo amplifier, an additional wiring (e.g. varistor) is required. Consult our applications department beforehand.

A personal safe operation of the holding brake requires an additional contact (normally opened) in the braking circuit and an anti-surge-device (e.g. Varistor) for the brake.

Wiring example for SERVOSTAR[®] :

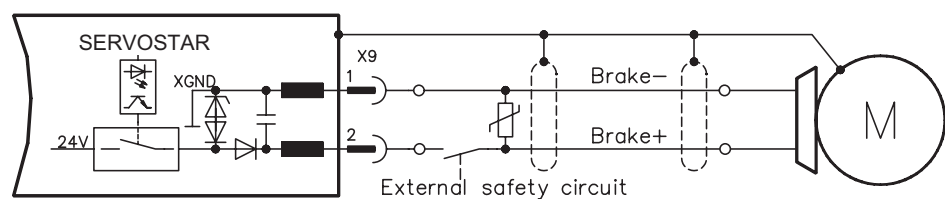

1.10 Selection criteria

The three-phase servomotors are designed to operate with SERVOSTAR servo amplifiers. Together, both units form a closed speed or torque control loop.

The most important selection criteria are:

—	Standstill torque	M_0	[Nm]
—	Rated speed	n_n	[min ⁻¹]
—	Moment of inertia of motor and load	J	[kgcm ²]
—	Effective torque (calculated)	M_{rms}	[Nm]

When calculating the motors and servo amplifiers which are required, take account of the static load **and** the dynamic load (acceleration/braking). Collected formula and examples of the calculations are available from our applications department.

1.11 Options

- 09- Special flanges and shafts are possible, we invite inquiries.
- G- Built-in holding brake.
- J- Radial shaft-sealing rings:
A radial shaft-sealing ring can be supplied at extra charge to seal against oil mist and oil spray. This increases the protection rating of the shaft bushing to IP65. The sealing ring is not suitable for dry running. When a holding brake is built in, the motor length increases by option -J- for 10mm.
- 65- Low tolerance for flange and shaft dimensions and increased concentricity and angularity according to DIN 42955
- 67- Shaft end precisely ground for oil tight seal, tolerance field k5
- TI- Tropical insulation
- BV- The rated torque in the series 6SM56..100 can be increased by fitting a separately driven fan. The fan has the intake on the B-side, cools the motor surface and exhausts to the A-side. For motors of the 6SM100 series, the fan is also obtainable with a shortened bonnet. The electrical connection of the fan is carried out via a connector. The mating connector is included in the delivery package of the option. The protection rating of the motor with a fan is IP54.
- K- Mounting flange for Stöber bevel gear
- 2K- Special varnish with 2-component enamel.
- 426- Encoder adaptor for ROD426/ROQ425 with coupling and eccentric washers.

1.12 Nameplate

The nameplate depicted below is attached to the side of the servomotor. The information described below is printed in the individual fields.

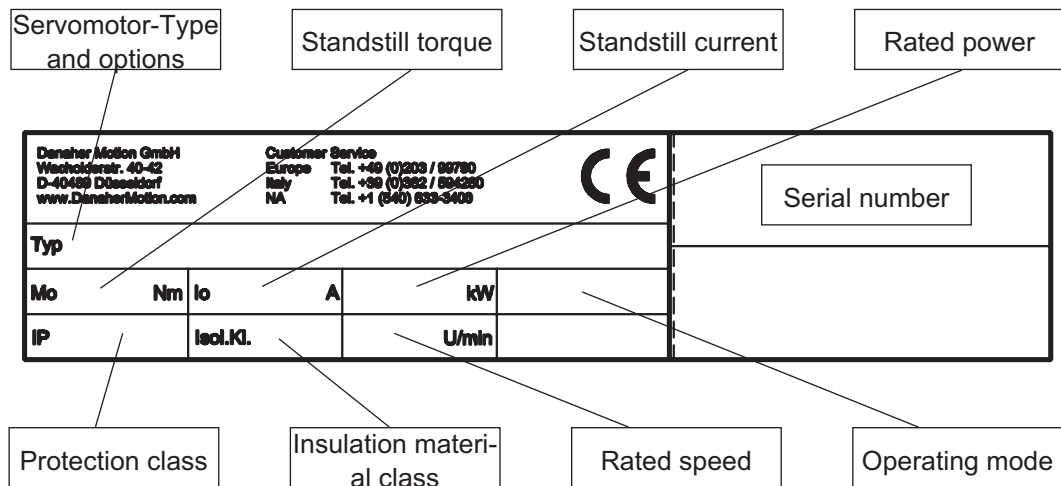

1.13 Technical data

1.13.1 Definitions

Standstill torque M_0 [Nm]

The standstill torque can be maintained indefinitely at a speed $n=0 \text{ min}^{-1}$ and rated ambient conditions.

Rated torque M_n [Nm]

The rated torque is produced when the motor is drawing the rated current at the rated speed. The rated torque can be produced indefinitely at the rated speed in continuous operation (S1).

Standstill current $I_{0\text{rms}}$ [A]

The standstill current is the effective sinusoidal current which the motor draws during standstill to produce the standstill torque.

Rated current I_{nrms} [A]

The rated current is the effective sinusoidal current which the motor draws at the rated speed in order to produce the rated torque.

Peak current (pulse current) $I_{0\text{max}}$ [A]

The peak current (effective sinusoidal value) should not exceed 4-times the rated current. The actual value is determined by the peak current of the servo amplifier which is used.

Torque constant K_{Trms} [Nm/A]

The torque constant defines how much torque in Nm is produced by the motor with 1A r.m.s. current. The relationship is $M=I \times K_T$

Voltage constant K_E [V/1000min⁻¹]

The voltage constant defines the induced motor EMF, as a sinusoidal peak value between two terminals, per 1000 rpm

Rotor moment of inertia J [kgcm²]

The constant J is a measure of the acceleration capability of the motor. For instance, at I_0 the acceleration time t_b from 0 to 3000 rpm is given as:

$$t_b \text{ [s]} = \frac{3000 \times 2\pi \times m^2}{M_0 \times 60\text{s} \times 10^4 \times \text{cm}^2} \times J \quad \text{with } M_0 \text{ in Nm and } J \text{ in kgcm}^2$$

Thermal time constant t_{th} [min]

The constant t_{th} defines the time for the cold motor, under a load of I_0 , to heat up to an overtemperature of 0.63×105 Kelvin. This temperature rise happens in a much shorter time when the motor is loaded with the rated current.

Release delay time t_{BRH} [ms] / Application delay time t_{BRL} [ms] of the brake

These constants define the response times of the holding brake when operated with the rated voltage from the SERVOSTAR servo amplifier.

1.13.2 Technical data 6SM45..100

Data	Sym	Dim	6SM 45S-3000	6SM 45M-3000	6SM 45L-3000	6SM 56S-3000	6SM 56M-3000	6SM 56L-3000	6SM 71K-3000	6SM 71S-3000	6SM 71M-3000	6SM 100K-3000	6SM 100S-3000	6SM 100M-3000	6SM 100L-3000		
Standstill torque	M ₀	Nm	0,85	1,7	3,2	3,8	7,0	10,0	10,5	16,5	22,0	25,0	36,0	46,0	57,0		
Standstill current	I _{0rms}	A	1,3	1,3	2,4	2,8	4,8	7,6	8,0	12,3	15,6	18,8	26,7	35,0	42,0		
Rated speed	n _n	min ⁻¹	3000	3000	3000	3000	3000	3000	3000	3000	3000	3000	3000	3000	3000		
Torque constant	K _{Trms}	Nm/A	0,68	1,36	1,36	1,33	1,45	1,32	1,31	1,35	1,41	1,33	1,35	1,32	1,35		
Voltage constant	K _E	mV/min	58	116	116	114	124	113	112	115	121	114	116	113	115		
Mains supply voltage	U _n	V	400														
Rated torque at n _n	M _n	Nm	0,8	1,6	2,9	3,6	6,4	8,4	9,5	13,4	16,3	19,9	24,6	27,1	28,0		
Rated current	I _n	A	1,4	1,3	2,3	2,9	4,7	6,7	7,6	10,5	12,2	15,7	19,2	21,8	22,5		
Rated power	P _n	kW	0,25	0,5	0,91	1,13	2,0	2,6	3,0	4,2	5,1	6,2	7,7	8,5	8,8		
Peak current	I _{0max}	A	4,7	5,6	9,6	12,4	19,6	28,3	32,0	44,0	51,0	72,0	113,0	150,0	180,0		
Motor pole no.	p _{Mot}	-	6														
Resolver pole no.	p _{Res}	-	2														
Winding resistance Ph-Ph	R ₂₀	Ω	25,4	34,0	11,9	9,4	4,0	1,8	1,65	0,8	0,57	0,46	0,22	0,16	0,12		
Winding inductance Ph-Ph	L	mH	54,0	99,0	47,0	54,0	30,0	15,8	19,6	12,0	9,0	10,5	7,0	5,0	4,0		
Insulation class	-	-	F, DIN 57530														
Switch point therm contact	-	°C	145 ± 5														
Design	-	-	IM B5 (V1, V3), DIN 42950														
Rotor moment of inertia	J	kgcm ²	1,5	2,1	3,4	5,2	10,0	15,0	20,0	31,0	42,0	74,0	108,0	141,0	175,0		
Static friction torque	M _R	Nm	0,127	0,131	0,14	0,154	0,18	0,208	0,23	0,28	0,334	0,4	0,49	0,58	0,67		
Radial load permitted at shaft end with n _n	F _R	N	370			530			700			1050					
Axial load permitted at shaft end with n _n	F _A	N	120			170			230			350					
Tolerance class flange	-	-	N, DIN42955														
Vibration class	-	-	N, DIN ISO 2373														
Thermal time constant	t _{TH}	min	15	20	20	20	20	20	25	30	35	32	40	41	46		
Weight standard	G	kg	4,5	5,5	6,5	6,1	8,0	10,3	11,7	15,8	20,0	26,0	33,0	40,0	49,0		
Order number standard	-	-	81681	81684	81752	81682	81683	81753	81679	81754	81680	84855	84856	84876	84874		
EMV-RES connector	-	-	12 poles, round														
RES cable, shielded	-	mm ²	4x2x0,25														
Power connection	-	stud	M4					M6			M8						
Motor cable, shielded	-	mm ²	4x1 or 4x1,5					4x2,5			4x4	4x6	4x10	4x16			
max. Ø of motor cable	-	mm	15					20			28						
max. Ø of braking cable	-	mm	8					12,5									
Holding torque	M _{BR}	Nm	6,5			12			20			60					
Operating voltage	U _{BR}	V=	24 +6/-10%														
electrical power	P _{BR}	W	16			18			22			50					
Moment of inertia	J _{BR}	kgcm ²	1,06			3,6			9,5			57,5					
Release delay time	t _{BRH}	ms	10 - 30			30 - 60			20 - 60			70 - 160					
Application delay time	t _{BRL}	ms	5 - 15			10 - 20			10 - 35			30 - 60					
Weight of the brake	G _{BR}	kg	0,6			1,1			1,9			5,4					
Motor cable with brake	-	mm ²	4x1 + 2x0,75 or 4x1,5 + 2x0,75					4x2,5 + 2x1					-				
Separate braking cable	-	mm ²	4x1,5 or 4x2,5														
Order number with -G-	-	-	81870	81869	81871	81868	81867	81866	81865	81864	81863	84699	84857	84877	84875		

1.13.3 Technical data 6SM56..100-BV

Data	Sym	Dim	6SM 56S-3000-BV	6SM 56M-3000-BV	6SM 56L-3000-BV	6SM 71K-3000-BV	6SM 71S-3000-BV	6SM 71M-3000-BV	6SM 100K-3000-BV	6SM 100S-3000-BV	6SM 100M-3000-BV	6SM 100L-3000-BV
Standstill torque	M _{0BV}	Nm	4,8	9,2	13,2	14,0	23,0	31,0	36,0	53,0	69,0	84,0
Standstill current	I _{0BV}	A	3,6	6,3	10,0	10,7	17,1	22,0	27,1	39,3	52,2	62,2
Rated speed	n _n	min ⁻¹	3000	3000	3000	3000	3000	3000	3000	3000	3000	3000
Torque constant	K _{Trms}	Nm/A	1,33	1,45	1,32	1,31	1,35	1,41	1,33	1,35	1,32	1,35
Voltage constant	K _E	mV/min	114	124	113	112	115	121	114	116	113	115
Mains supply voltage	U _n	V	400									
Rated torque at n _n	M _{nBV}	Nm	4,8	9,0	12,5	13,7	21,9	28,6	35,1	50,1	63,1	75,0
Rated current	I _n	A	3,8	6,5	9,8	10,8	16,8	21,0	27,1	38,1	49,1	57,2
Rated power	P _n	kW	1,5	2,8	3,9	4,3	6,9	9,0	11,0	15,7	19,8	23,6
Peak current	I _{0max}	A	12,4	19,6	28,3	32,0	44,0	51,0	72,0	113,0	150,0	180,0
Motor pole no.	p _{Mot}	-	6									
Resolver pole no.	p _{Res}	-	2									
Winding resistance Phase-Phase	R ₂₀	Ω	9,4	4,0	1,8	1,65	0,8	0,57	0,46	0,22	0,16	0,12
Winding inductance Phase-Phase	L	mH	54,0	30,0	15,8	19,6	12,0	9,0	10,5	7,0	5,0	4,0
Insulation class	-	-	F, DIN 57530									
Switch point thermal contact	-	°C	145 ± 5									
Design	-	-	IM B5 (V1, V3), DIN 42950									
Rotor moment of inertia	J	kgcm ²	5,2	10,0	15,0	20,0	31,0	42,0	74,0	108,0	141,0	175,0
Static friction torque	M _R	Nm	0,154	0,18	0,208	0,23	0,28	0,334	0,4	0,49	0,58	0,67
Radial load permitted at shaft end with n _n	F _R	N	530			700			1050			
Axial load permitted at shaft end with n _n	F _A	N	170			230			350			
Tolerance class flange	-	-	N, DIN42955									
Vibration class	-	-	N, DIN ISO 2373									
Thermal time constant	t _{TH}	min	15	15	15	15	20	20	20	20	25	25
Weight incl. ventilator	G	kg	7,8	9,7	12,0	14,2	18,2	22,5	29,5	36,5	43,5	52,5
Order number motor	-	-	81682	81683	81753	81679	81754	81680	84855	84856	84876	84874
Order number -BV-	-	-	65079			65078			65080			
EMV-RES connector	-	-	12 poles, round									
RES cable, shielded	-	mm ²	4x2x0,25									
Power connection	-	stud	M4			M6			M8			
Motor cable, shielded	-	mm ²	4x1,5			4x4			4x6	4x16		
max. ∅ of motor cable	-	mm	15			20			28			
max. ∅ of braking cable	-	mm	8			12,5						
Holding torque	M _{BR}	Nm	12			20			60			
Operating voltage	U _{BR}	V=	24 +6/-10%									
electrical power	P _{BR}	W	18			22			50			
Moment of inertia	J _{BR}	kgcm ²	3,6			9,5			57,5			
Release delay time	t _{BRH}	ms	30 - 60			20 - 60			70 - 160			
Application delay time	t _{BRL}	ms	10 - 20			10 - 35			30 - 60			
Weight of the brake	G _{BR}	kg	1,1			1,9			5,4			
Order number with -G-	-	-	81868	81867	81866	81865	81864	81863	84699	84857	84877	84875
Motor cable with brake, shielded	-	mm ²	4x1 + 2x0,75 or 4x1,5 + 2x0,75			4x2,5 + 2x1			-			
Separate braking cable	-	mm ²	4x1,5 or 4x2,5									
Operating voltage ventilator	U _{BV}	V	230 (50-60 Hz)									
Rated current ventilator	I _{BV}	A	0,12			0,25			0,25			
Connector	-	-	4 poles									
Protection class with ventilator	-	-	IP54									

This page has been deliberately left blank.

2 Installation / Commissioning

2.1 Important notes

- Check that the servo amplifier and motor match each other. Compare the rated voltage and rated current of the unit. Carry out the wiring according to the wiring diagram in the Installation and Commissioning Instructions for the servo amplifier. The connections to the motor are shown on pages 24 and 33. Notes on the connection methods can be found on page 20.
- Ensure that there is proper earthing of the servo amplifier and the motor.
- Route the power and control cables as separately as possible from one another (separation > 20 cm). This will improve the immunity of the system to electromagnetic interference.
If a motor power cable is used which includes integral brake control leads, then these brake control leads must be shielded. The shielding must be connected at both ends (see under Installation Instructions for the servo amplifier).
- Install all cables carrying a heavy current with an adequate cross-section, as per EN 60204. The recommended cross-section can be found in the Technical data.



Attention!

If a servo amplifier of the series SERVOSTAR is used and the motor cable exceeds 25m, a boxed choke (type 3YLNxx, manufactured by Danaher Motion) and motor leads with the following diameters must be used:

Servo amplifier	Max. cable diameter
digifas 7201...7206	4x1mm ²
SERVOSTAR 601...606	4x1mm ²
SERVOSTAR 610	4x1,5mm ²
SERVOSTAR 620	4x2,5 mm ²

- Connect up all shielding via a wide surface-area contact (low impedance) and metallized connector housings or EMC-PG glands.
- Check the compliance to the permitted radial and axial forces F_R and F_A . When you use a toothed belt drive, the **minimal** permitted diameter of the pinion e.g. follows from the equation: $d_{\min} \geq \frac{M_0}{F_R} \times 2$.
- Ensure that there is adequate heat transfer in the surroundings and the motor flange, so that the maximum permissible flange temperature is not exceeded in S1 operation.



Caution!

Never undo the electrical connections to the motor while it is energised. A dangerous voltage, resulting from residual charge, can be still present on the capacitors up to 300 seconds after switch-off of the mains supply. Measure the DC-link voltage and wait until it has fallen below 40V. Even when the motor is not rotating, control and power leads may be live.

2.2 Assembly / Wiring

Only qualified staff with knowledge of mechanical engineering are permitted to assemble the motor.

Only staff qualified and trained in electrical engineering are allowed to wire up the motor.

The procedure is described as an example. A different method may be appropriate or necessary, depending on the application of the equipment.



Warning!

Protect the motor from unacceptable stresses.

Take care, especially during transport and handling, that components are not bent and that insulation clearances are not altered.

Always make sure that the motors are de-energized during assembly and wiring, i.e. No voltage may be switched on for any piece of equipment which is to be connected.

Ensure that the switch cabinet remains turned off (barrier, warning signs etc.). The individual voltages will only be turned on again during commissioning



Note!

The ground symbol |||| , which you will find in the wiring diagrams, indicates that you must provide an electrical connection, with as large a surface area as possible, between the unit indicated and the mounting plate in the switch cabinet. This connection is to suppress HF interference and must not be confused with the PE (protective earth) symbol ≡ (protective measure to EN 60204).

To wire up the motor, use the wiring diagrams in the Installation and Commissioning Instructions of the servo amplifier which is used.

The following notes should help you to carry out the assembly and wiring in an appropriate sequence, without overlooking anything.



Site	<p>The site must be free of conductive and aggressive material. For V3-mounting (shaft end upwards), make sure that no liquids can enter the bearings. If an encapsulated assembly is required, please consult our applications department beforehand.</p>
Ventilation	<p>Ensure an unhindered ventilation of the motors and observe the permissible ambient and flange temperatures. For ambient temperatures above 40°C please consult our applications department beforehand.</p>
Assembly	<p>During assembly, take care that the motor is not overstressed when it is fixed in place.</p>
Cable selection	<p>Select cables according to EN 60204 See the table on page 17 when cable length exceeds 25m.</p>
Earthing Shielding	<p>Use correct earthing and EMC-shielding according to the Installation Instructions for the servo amplifier which is used. Earth the mounting plate and motor casing. For connection methods see page 20</p>
Wiring	<ul style="list-style-type: none">— Route power cables as separately as possible from control cables— Connect up the resolver— Connect the motor leads, install ring cores or motor chokes close to the servo amplifier, connect shields to shielding terminals or EMC connectors at both ends— Connect the holding brake, if used, Connect shielding at both ends.— Connect the separate fan, if used.
Check	<p>Final check of the installed wiring, according to the wiring diagram which was used</p>

2.2.1 Connection methods

- Carry out the wiring in accordance with the valid standards and regulations.
- Only use our preassembled shielded cables for the resolver connections.
- Connect up the shielding according to the wiring diagrams in the Installation Instructions for the servo amplifier.
- Incorrectly installed shielding inevitably leads to EMC interference.

In the table below you find all cables supplied by us. They are cUL approved. Further information referring to chemical, mechanical and electrical qualities can be received from our applications department.

Insulating material

Sheathing - PUR (Polyurethane, identification 11Y)
 core insulation - PETP (Polyesteraphtalate, identification 12Y)

Capacity

Motor cable - less than 150 pF/m
 Resolver cable - less than 120 pF/m

Technical Data

- All cables are suitable for trailing.
- Technical data refer to mobile usage of cables.
 Life time : 1 Million bending cycles
- The temperature range refers to the operation temperature.
- Identification:
 - N = numbered cores
 - F = cores with colour code according to DIN 47100
 - () = shielding

Cores [mm ²]	Identification	Temperature range [°C]	Cable diameter [mm]	Bending radius [mm]	Remarks
(4x1,0)	N	-30 / +80	10	100	Motor cable
(4x1,5)	N	-30 / +80	10,5	105	
(4x2,5)	N	-30 / +80	12,6	125	
(4x4)	N	-5 / +70	12,8	130	
(4x6)	N	-5 / +70	16,1	160	
(4x10)	N	-5 / +70	19,0	190	
(4x16)	N	-5 / +70	23,3	235	
(4x1,5)	N	-30 / +80	10,5	105	Braking cable
(4x2,5)	N	-30 / +80	12,6	125	
(4x1,0+(2x0,75))	F	-30 / +80	10,5	100	Motor cable with integral brake control leads
(4x1,5+(2x0,75))	N	-30 / +80	11,5	120	
(4x2,5+(2x1))	F	-30 / +80	14,2	145	Resolver cable
(4x2x0,25)	F	-30 / +80	7,7	70	

2.3 Commissioning

The procedure for commissioning is described as an example. A different method may be appropriate or necessary, depending on the application of the equipment.

Only specialist personnel with extensive knowledge in the areas of electrical engineering / drive technology are allowed to commission the drive unit of servo amplifier and motor.



Caution!

Check that all live connection points (terminal boxes) are safe against accidental contact. Deadly voltages can occur, up to 900V.

Never undo the electrical connections to the motor when it is live. The residual charge in the capacitors of the servo amplifier can produce dangerous voltages up to 300 seconds after the mains supply has been switched off.

The surface temperature of the motor can reach 100°C in operation. Check (measure) the temperature of the motor. Wait until the motor has cooled down below 40°C before touching it.

Make sure that, even if the drive starts to move unintentionally, no danger can result for personnel or machinery.

- 
- Check the assembly and orientation of the motor.
 - Check the drive components (clutch, gear unit, belt pulley) for the correct seating and setting (observe the permissible radial and axial forces).
 - Check the wiring and connections to the motor and the servo amplifier. Check that the earthing is correct.
 - Test the function of the holding brake, if used. (apply 24V, the brake must be released).
 - Check whether the rotor of the motor revolves freely (release the brake, if necessary). Listen out for grinding noises.
 - Check that all the required measures against accidental contact with live and moving parts have been carried out.
 - Carry out any further tests which are specifically required for your system.
 - Now commission the drive according to the commissioning instructions for the servo amplifier.
 - In multi-axis systems, individually commission each drive unit (servo amplifier and motor).

This page has been deliberately left blank.

3 Drawings

3.1 Non-ventilated motors

3.1.1 Dimensions 6SM45..100

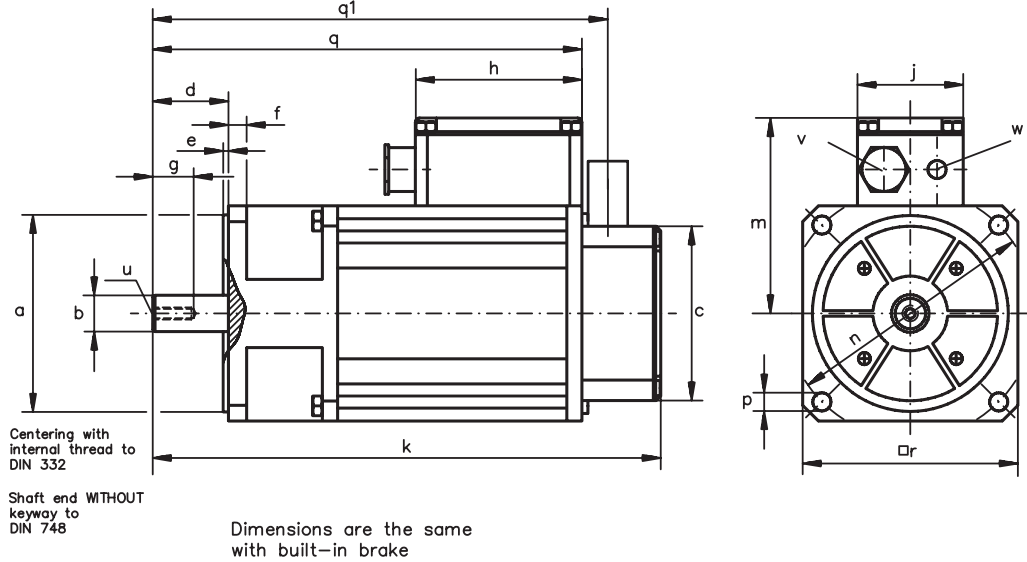

	$a_{\beta 6}$	b_{k6}	c	d	e	f	g	h	j	k	m	n	p	q	q1	r	u	v	w
	mm	mm	mm	mm	mm	mm	mm	mm	mm	mm	mm	mm	mm	mm	mm	mm	M	M	M
6SM45S-3000 6SM45M-3000 6SM45L-3000	80	14	99	30	3	8	17	85	66	195 220 270	95	100	7	160 185 235	175 200 250	90	5	20	16
6SM56S-3000 6SM56M-3000 6SM56L-3000	95	19	115	40	3	8	22	85	66	255 295 335	103	115	9	212 252 292	229 269 309	105	6	20	16
6SM71K-3000 6SM71S-3000 6SM71M-3000	130	24	115	50	3,5	12	27	110	70	316 366 416	129	165	12	273 323 373	290 340 390	142	8	25	16
6SM100K-3000 6SM100S-3000 6SM100M-3000 6SM100L-3000	180	32	115	58	4	13	42	150	135	367 415 463 511	174	215	14	324 372 420 468	341 389 437 485	190	12	40	16

3.1.2 Radial/axial force at the shaft end

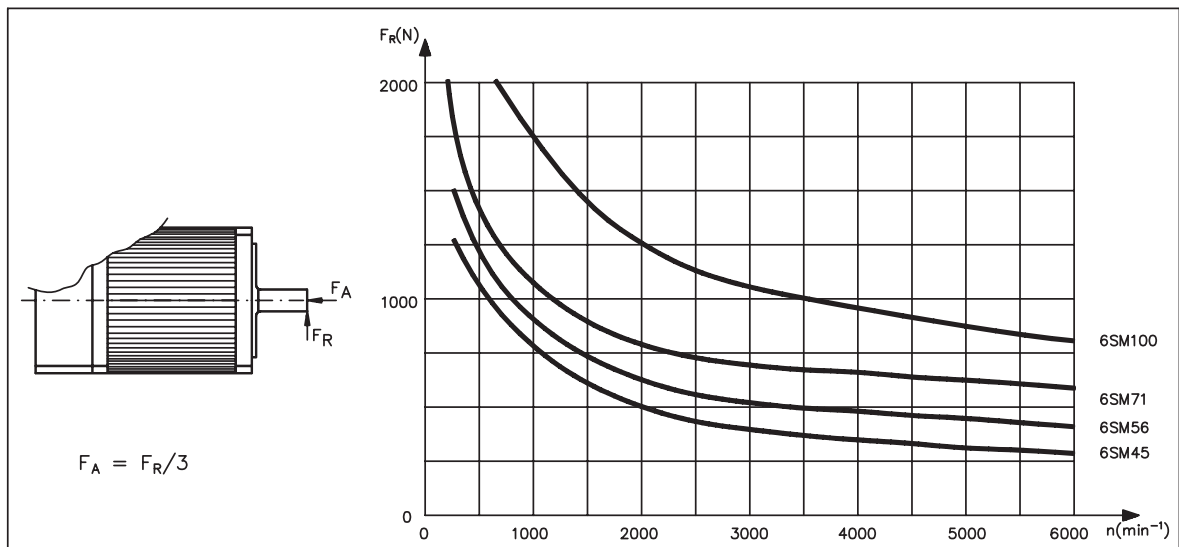

3.1.3 Wiring diagram 6SM45..100

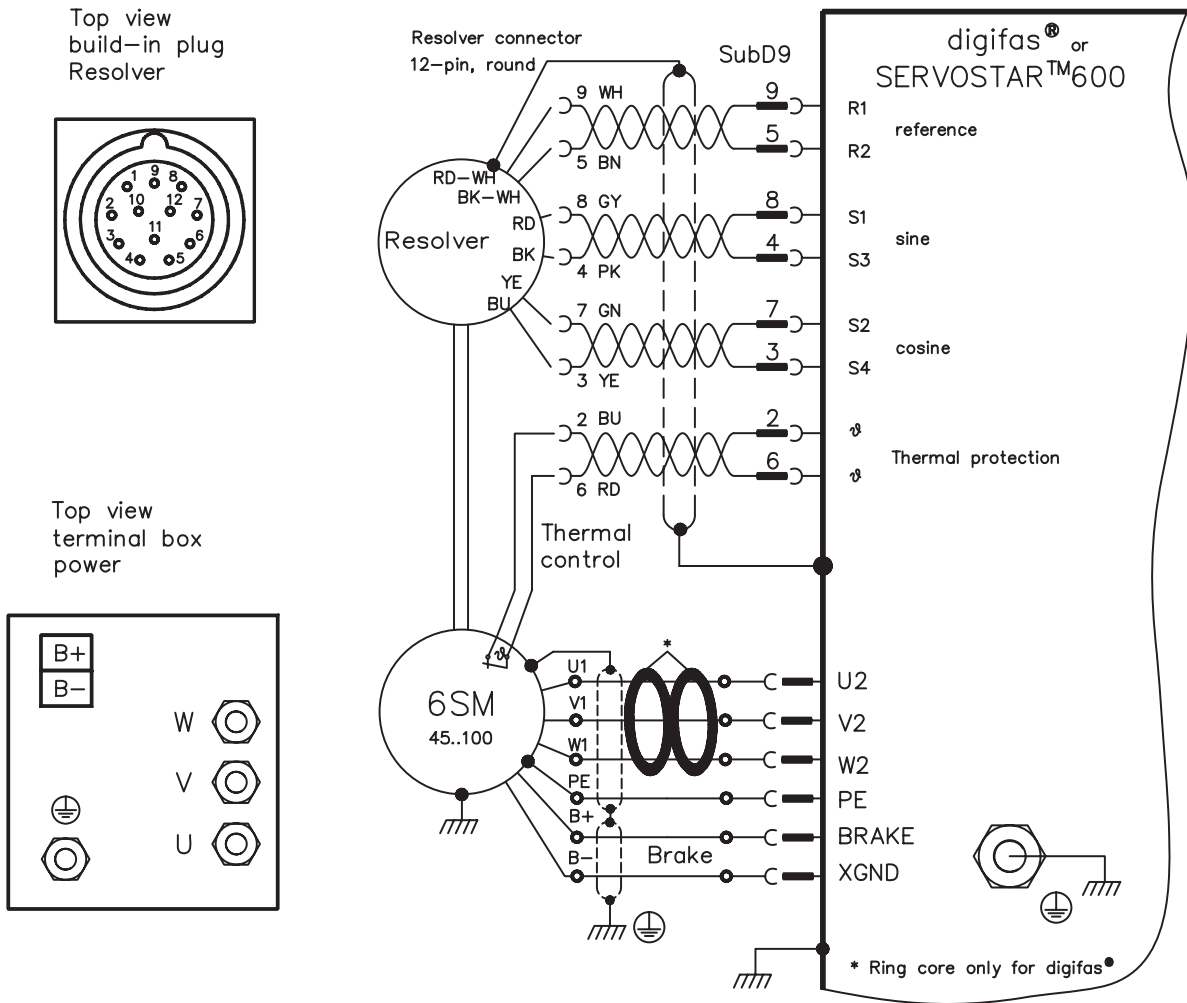

Top view build-in plug Resolver

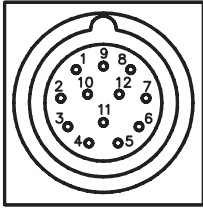

Top view terminal box power

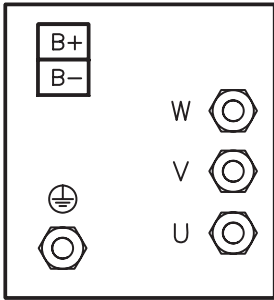

connector round, 12-poles

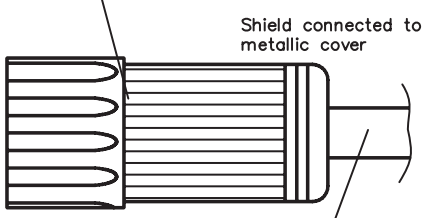

Shield connected to metallic cover

4 x 2 x 0,25 shielded, twisted pairs on request max. 100m

Sub-D connector 9-poles

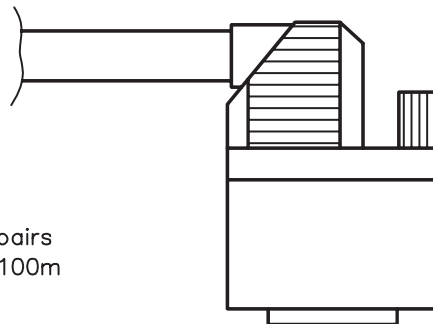

Shield connected to metallic cover

Length	Mat.No.
5m	84972
10m	84973
15m	84974
20m	84975

Colour coding acc. to IEC 757

Res. cable f. 6SM with connector

3.1.4 Torque characteristics 6SM45S-3000

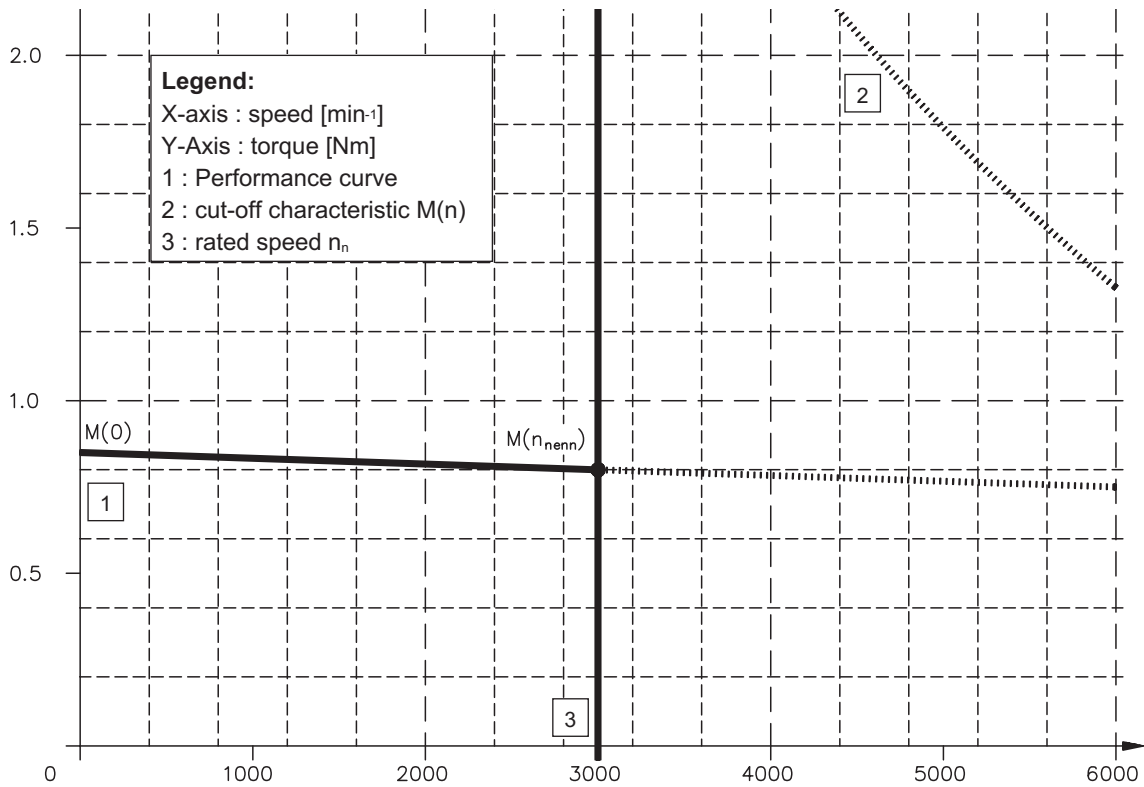

3.1.5 Torque characteristics 6SM45M-3000

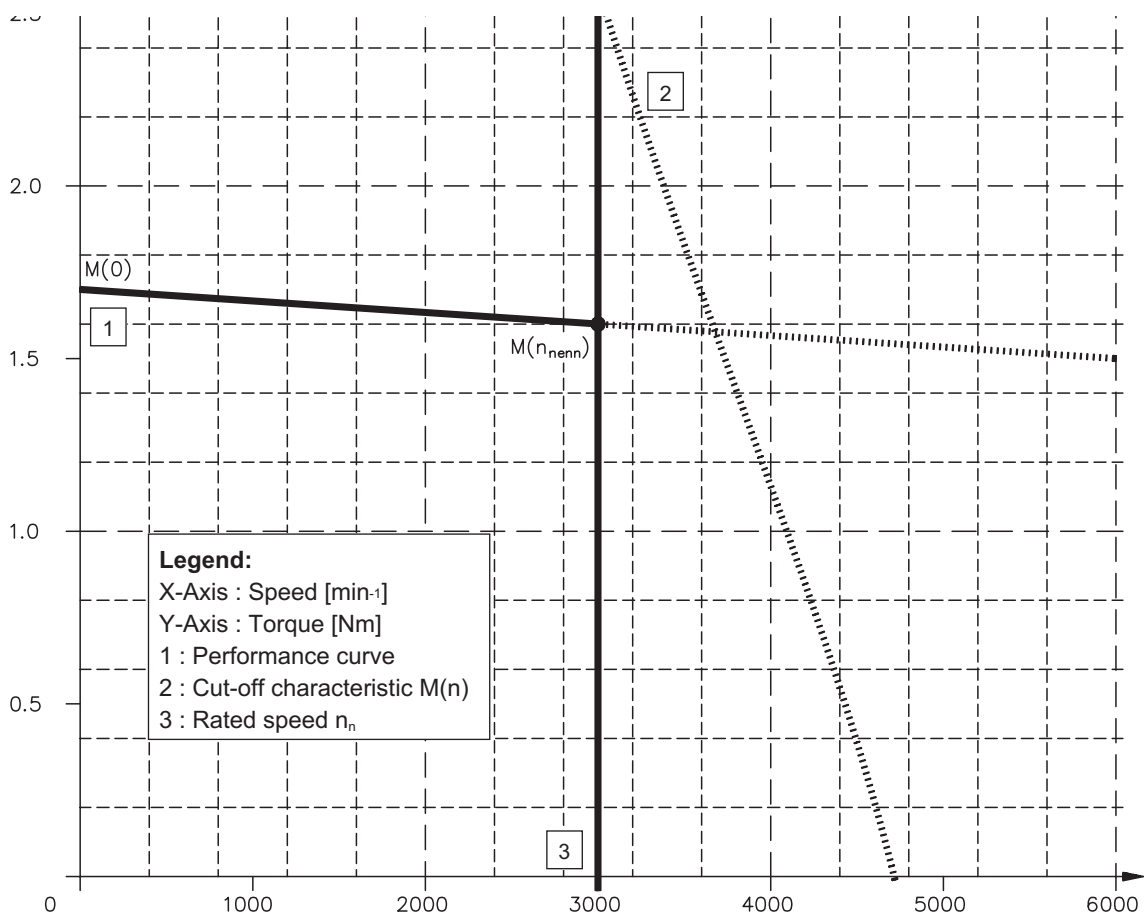

3.1.6 Torque characteristics 6SM45L-3000

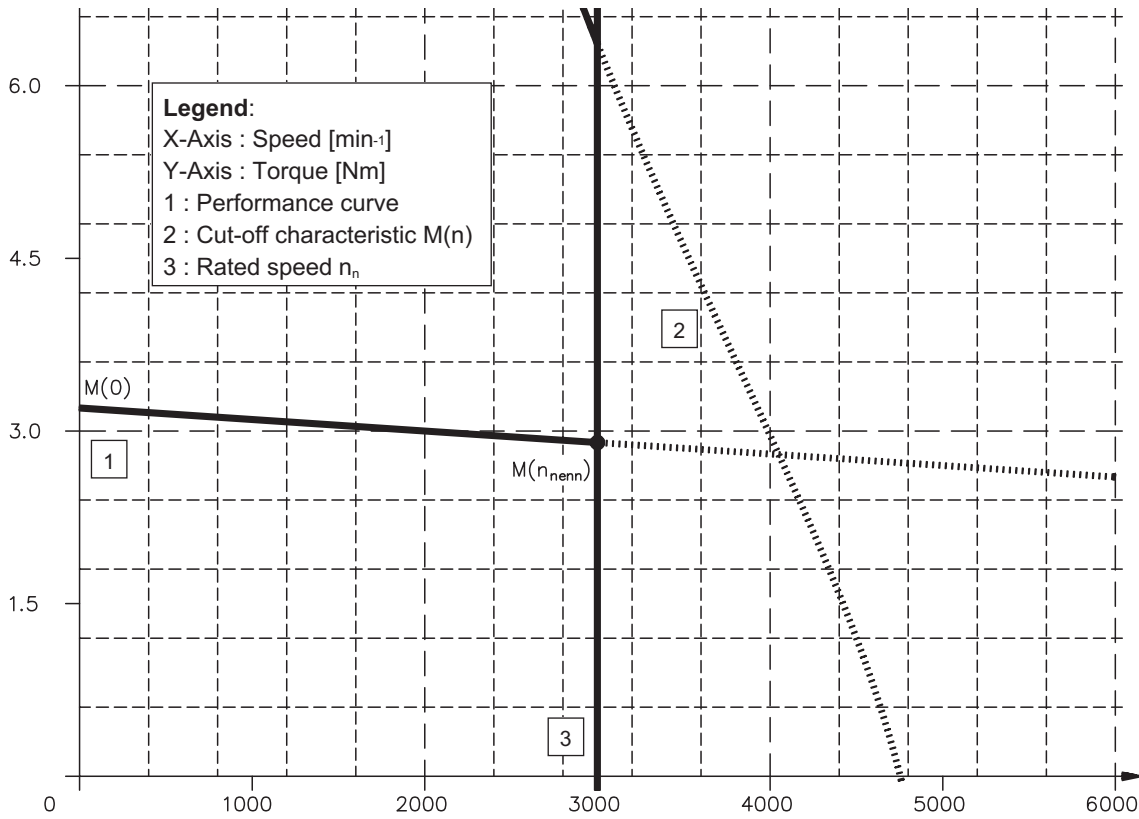

3.1.7 Torque characteristics 6SM56S-3000

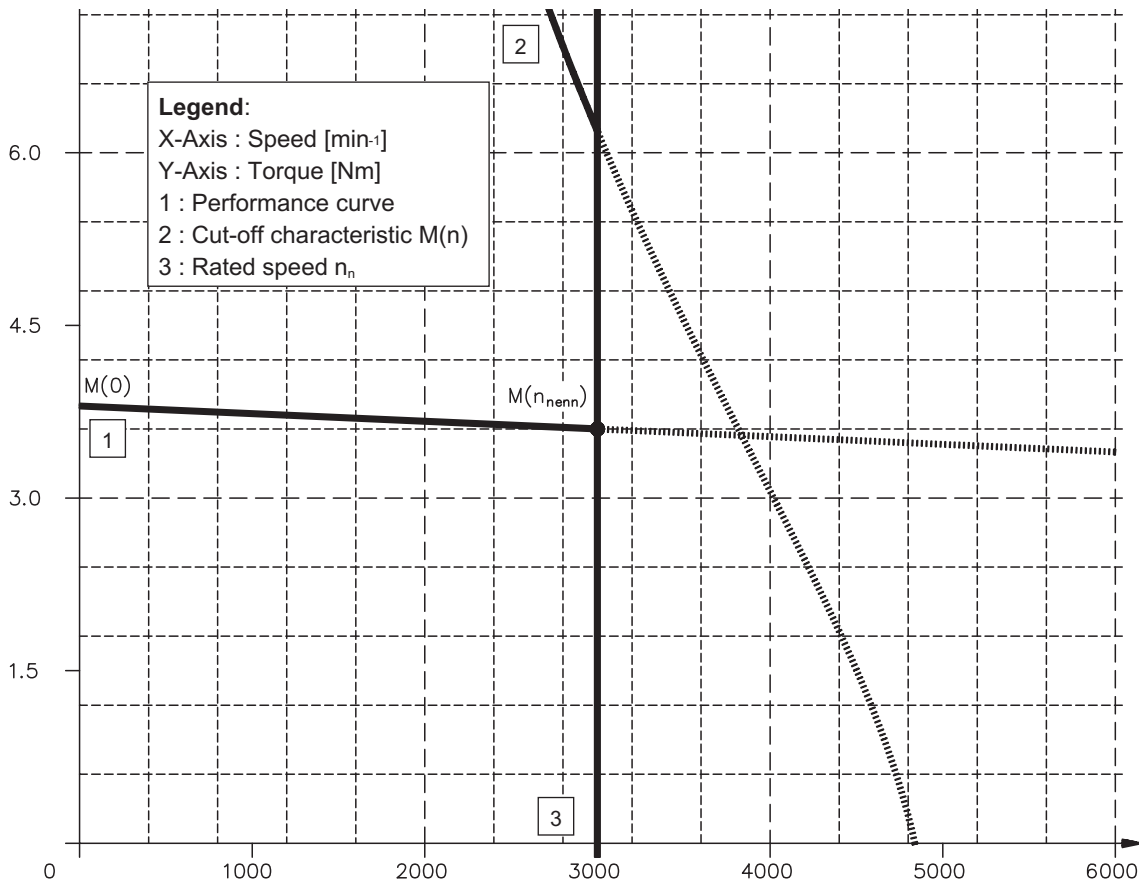

3.1.8 Torque characteristics 6SM56M-3000

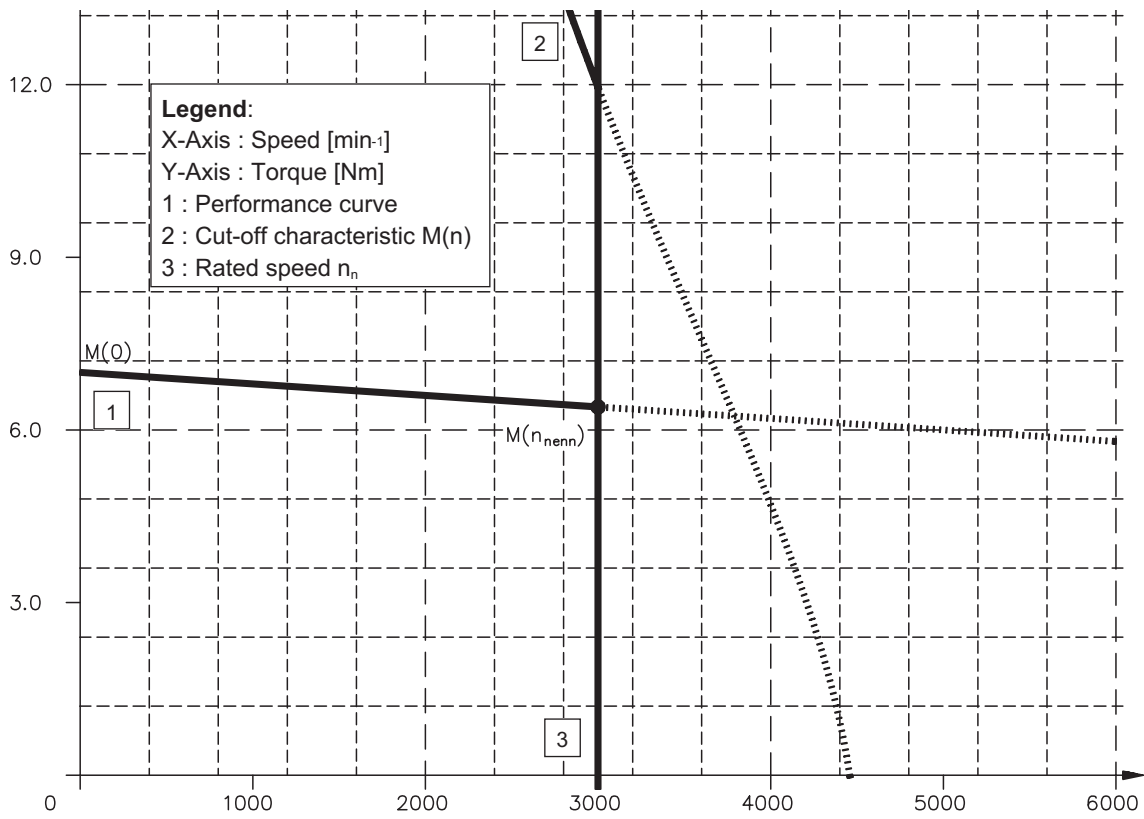

3.1.9 Torque characteristics 6SM56L-3000

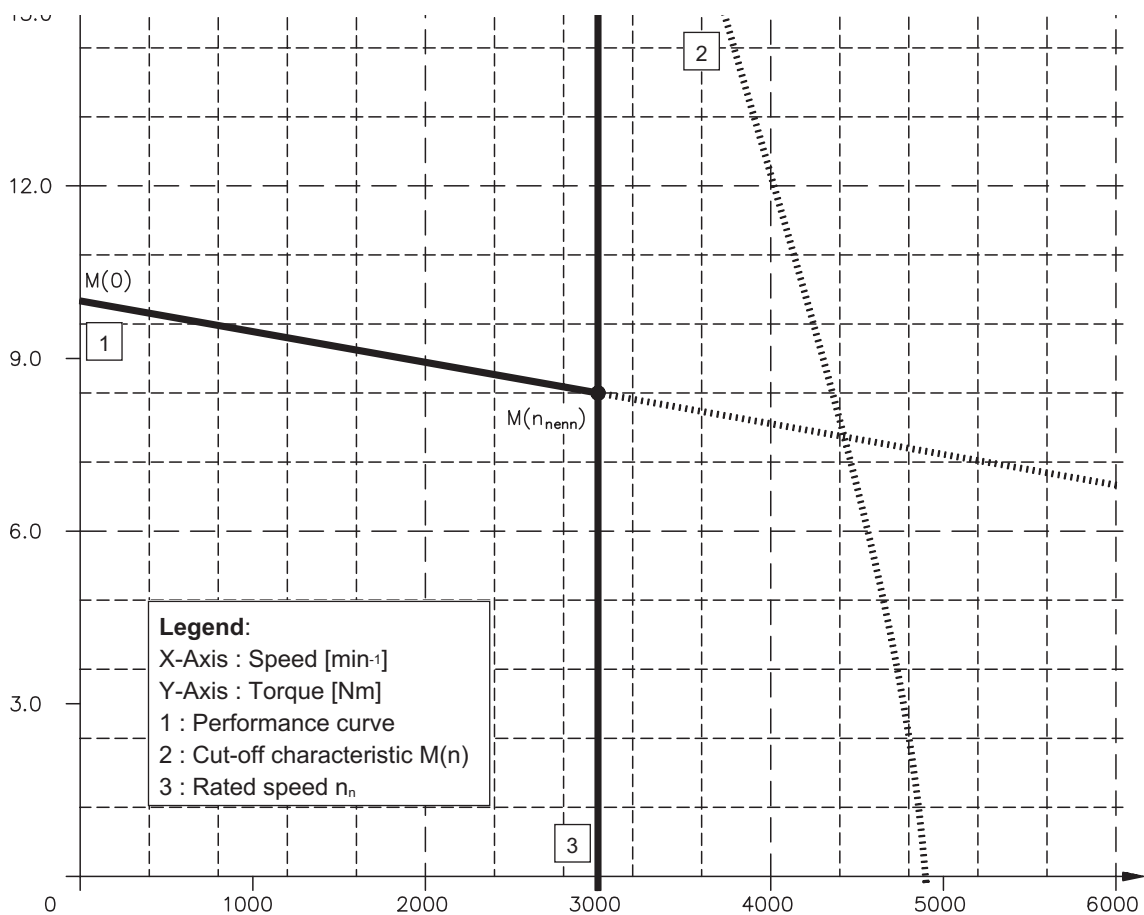

3.1.10 Torque characteristics 6SM71K-3000

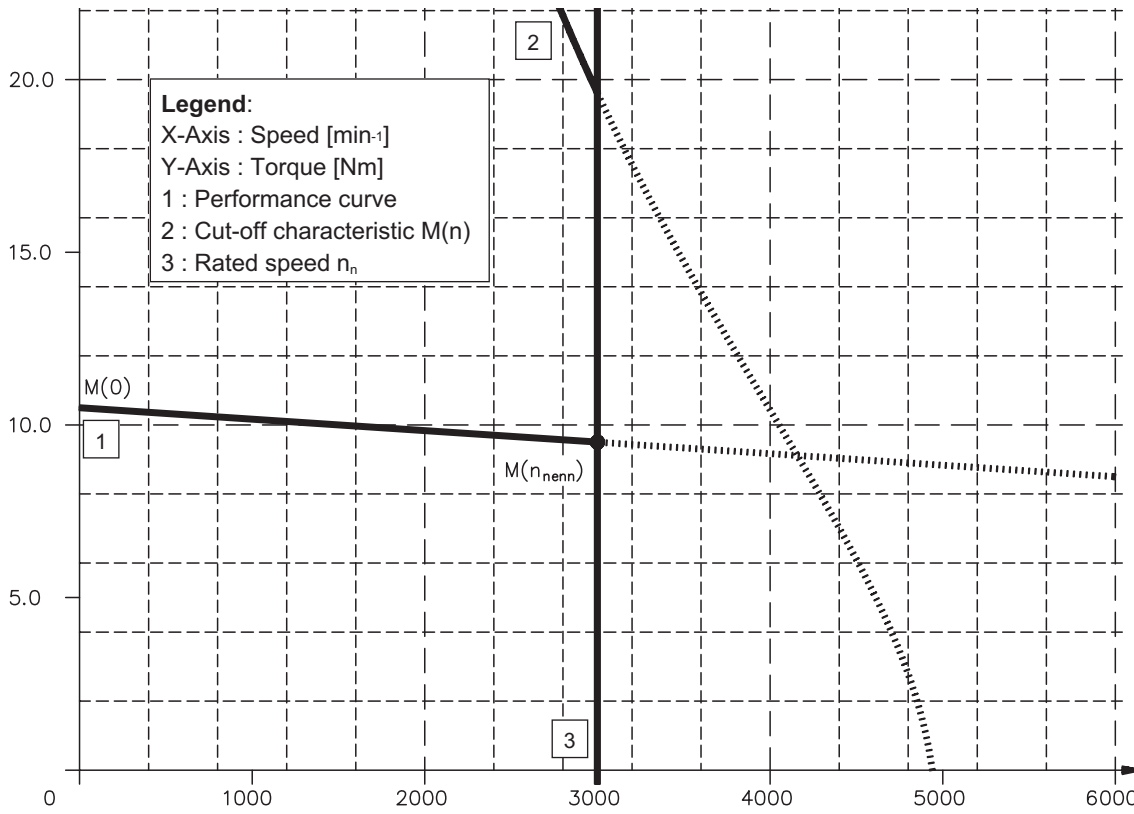

3.1.11 Torque characteristics 6SM71S-3000

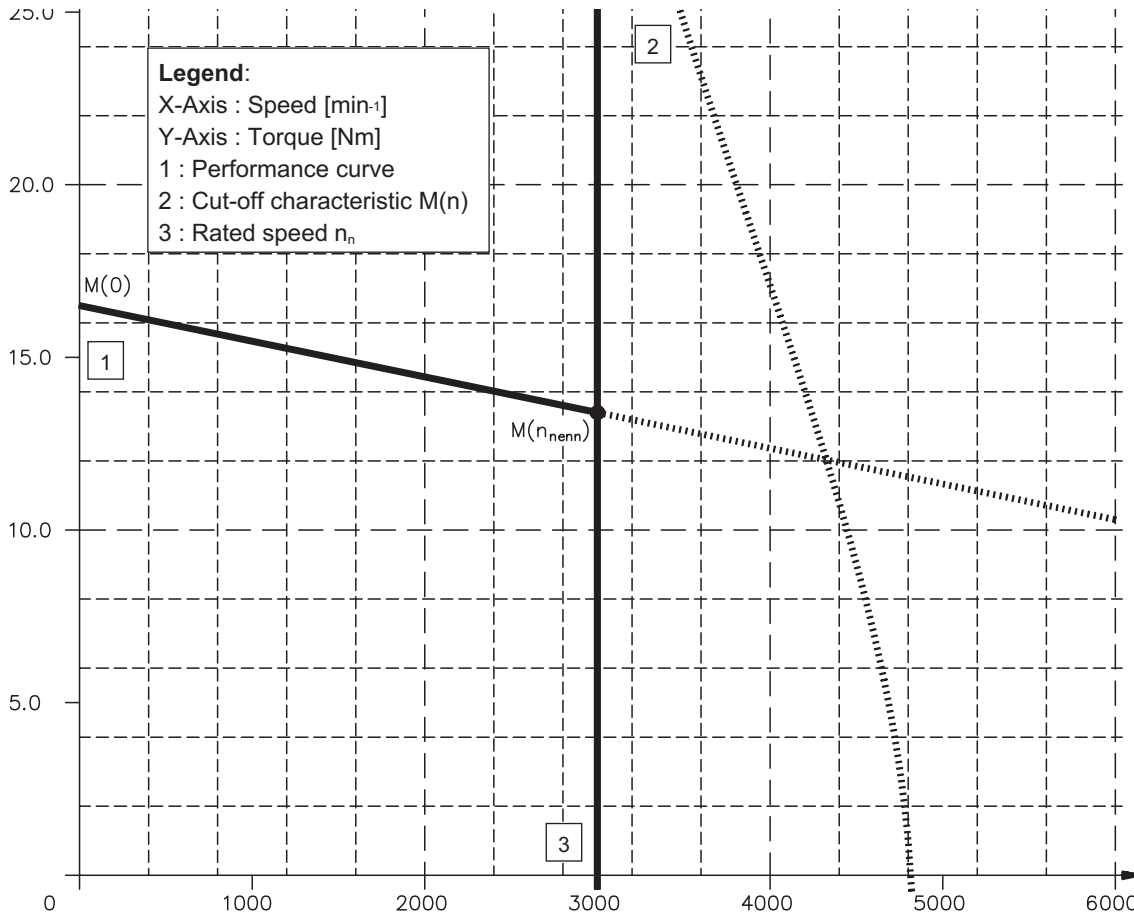

3.1.12 Torque characteristics 6SM71M-3000

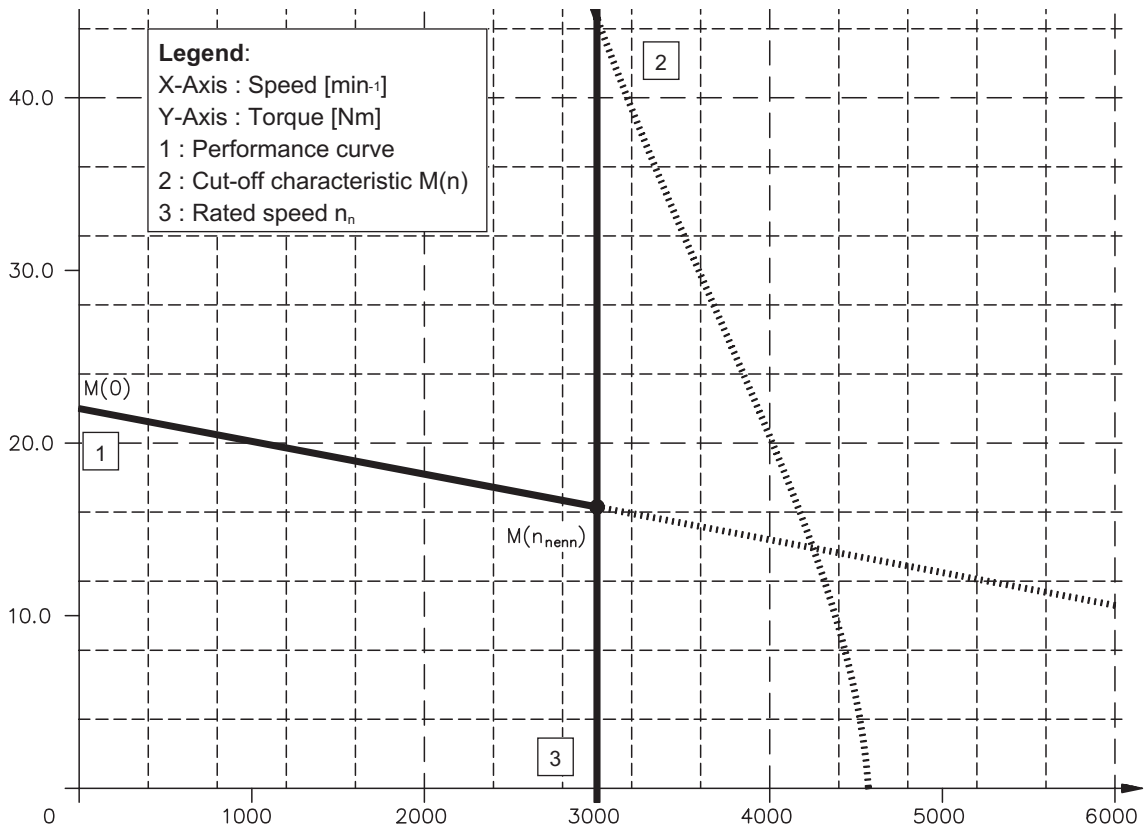

3.1.13 Torque characteristics 6SM100K-3000

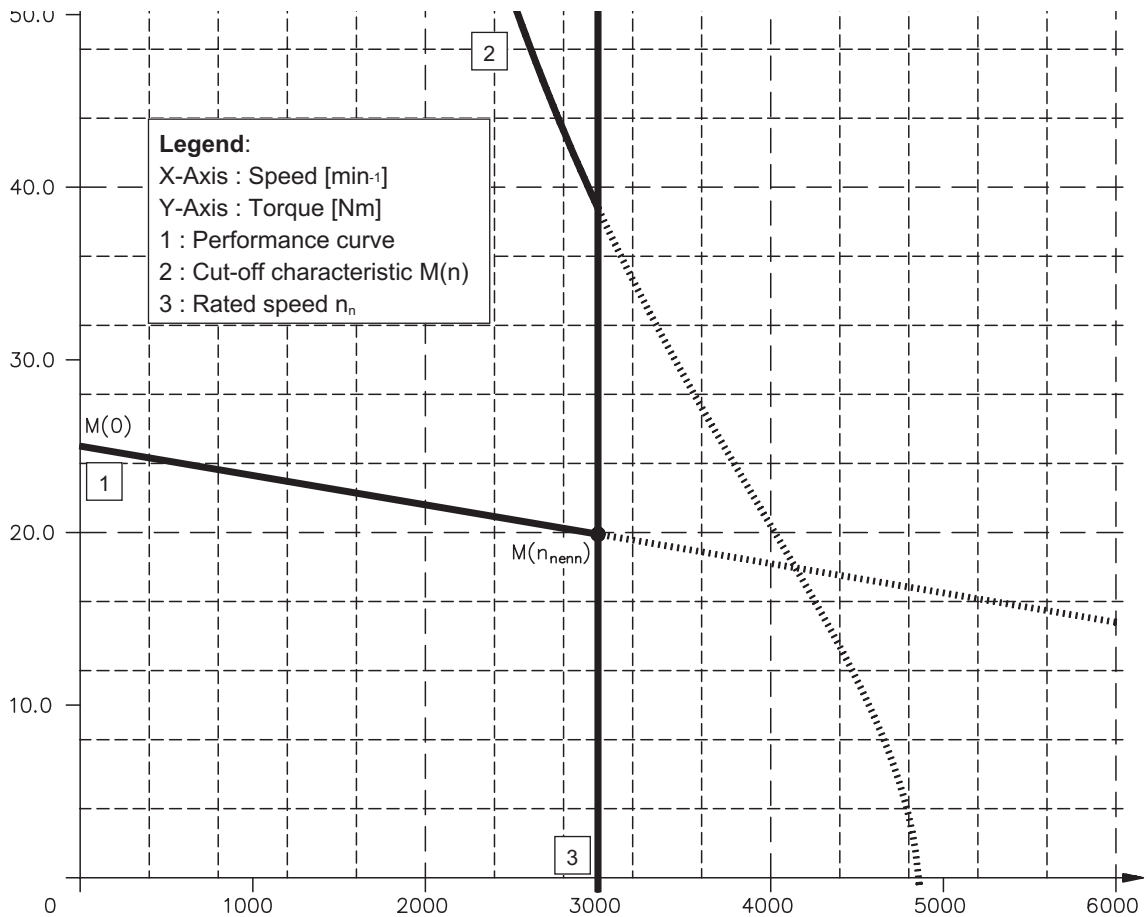

3.1.14 Torque characteristics 6SM100S-3000

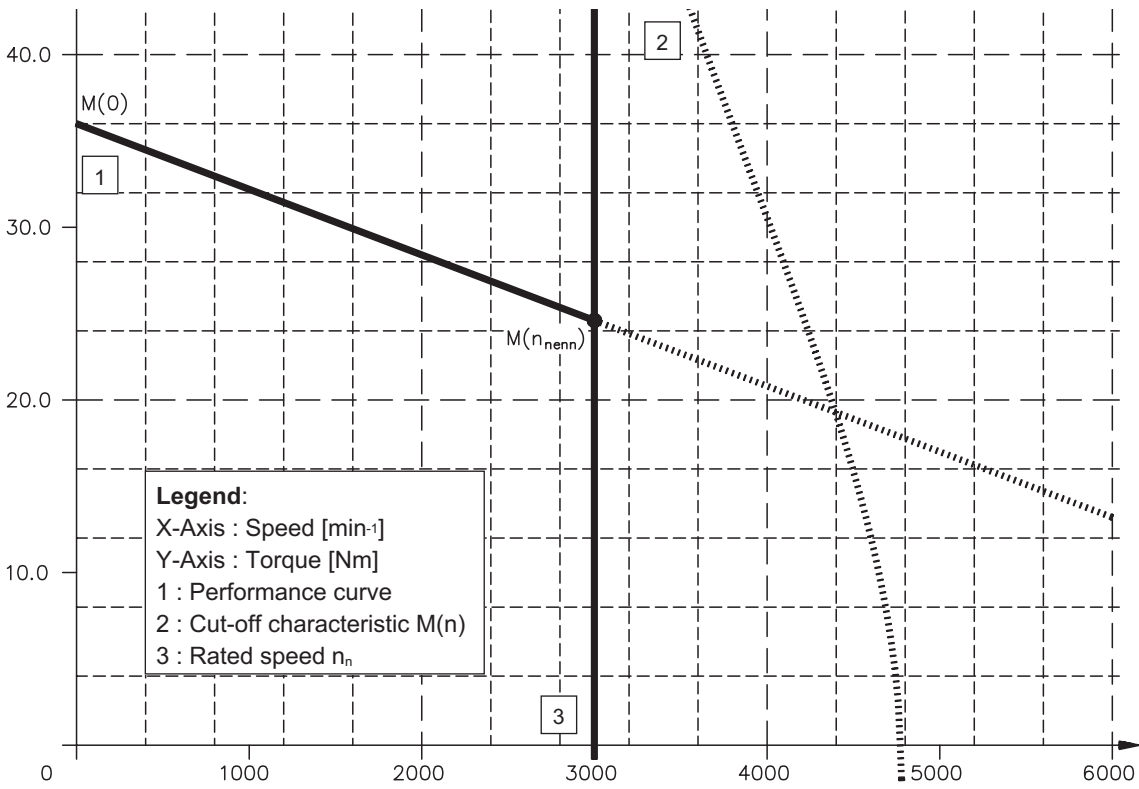

3.1.15 Torque characteristics 6SM100M-3000

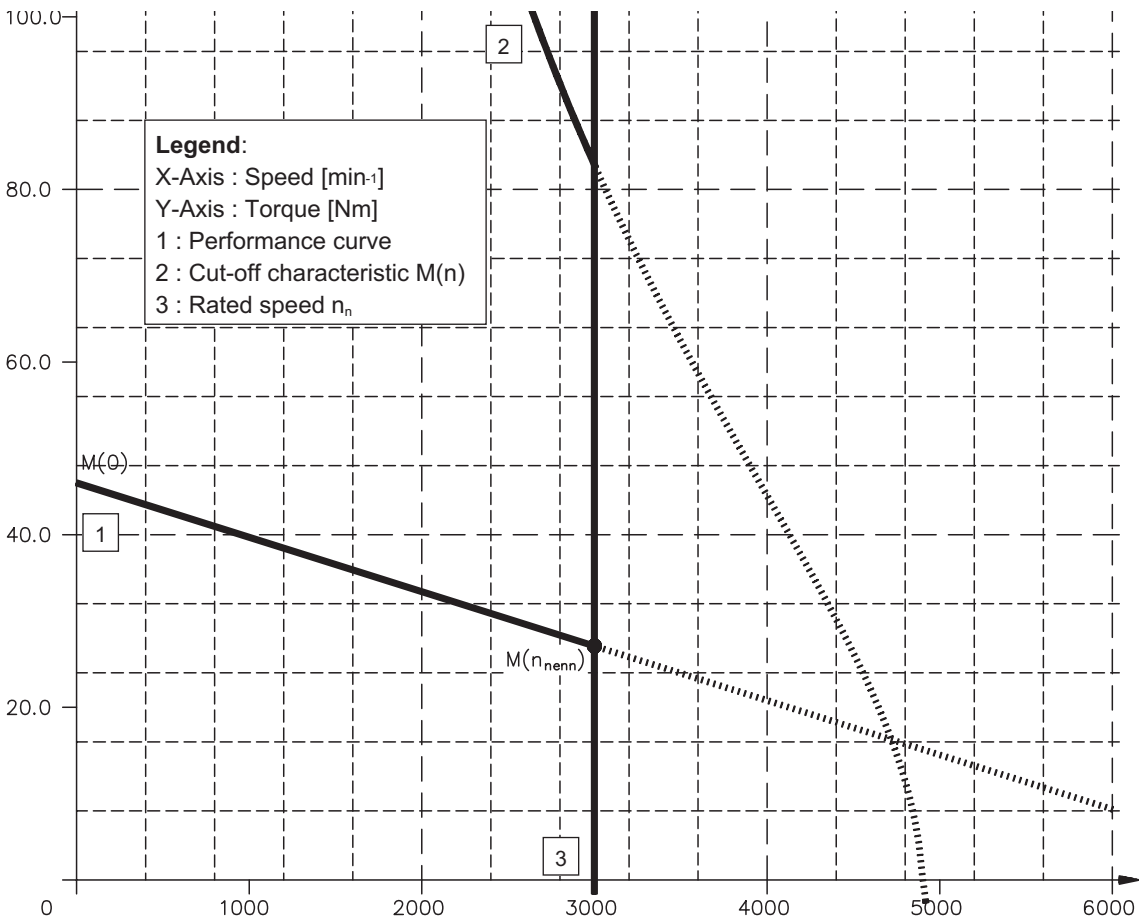

3.1.16 Torque characteristics 6SM100L-3000

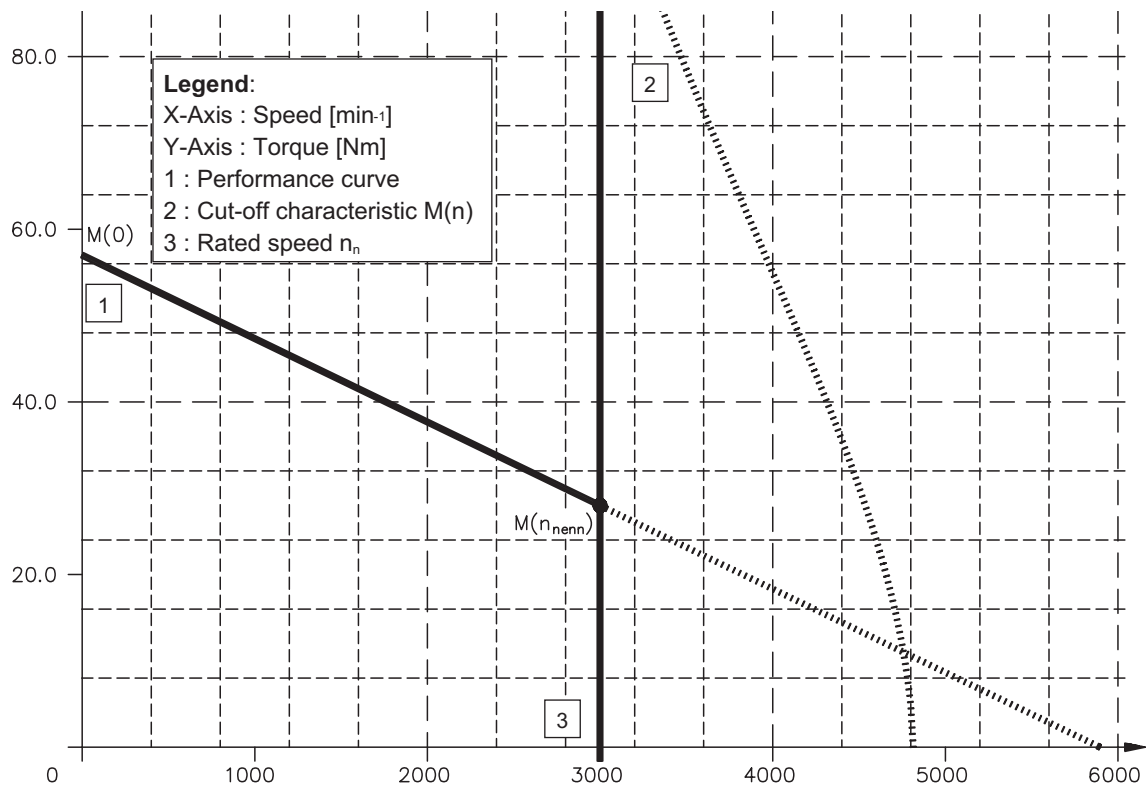

3.2 Ventilated motors

3.2.1 Dimensions 6SM56..100-BV

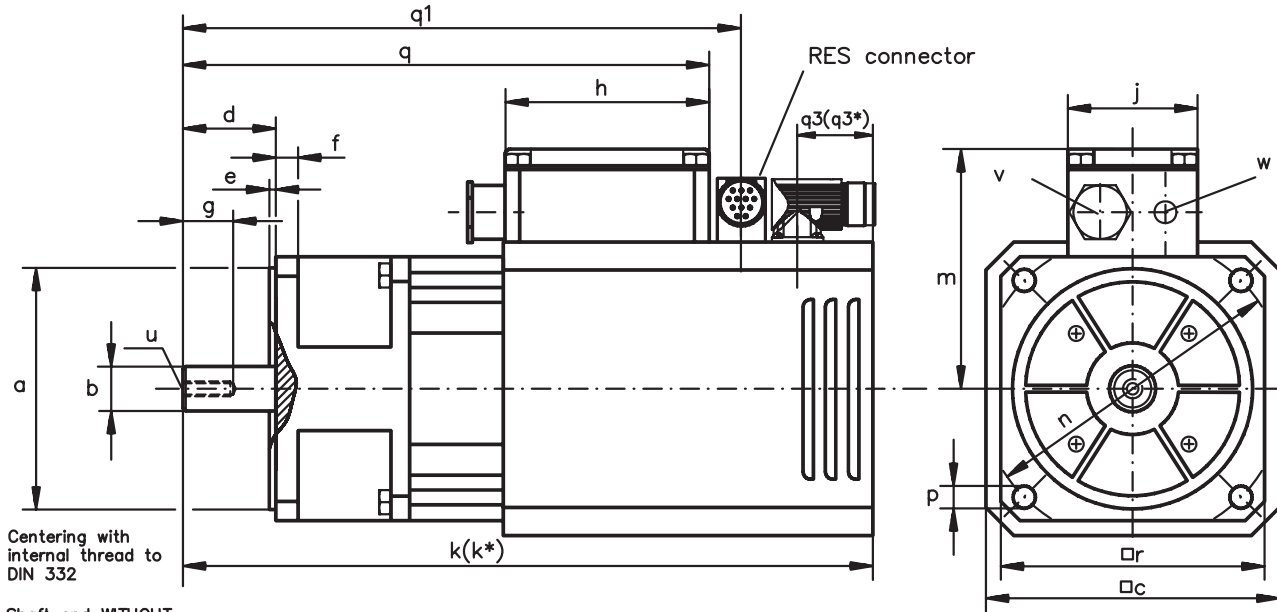

Centering with internal thread to DIN 332

Shaft end WITHOUT keyway to DIN 748

Dimensions are the same with built-in brake

	a_{j6}	b_{k6}	c	d	e	f	g	h	j	k	m	n	p	q	q1	q3	r	u	v	w
	mm	mm	mm	mm	mm	mm	mm	mm	mm	mm	mm	mm	mm	mm	mm	mm	mm	M	M	M
6SM56S-3000-BV 6SM56M-3000-BV 6SM56L-3000-BV	95	19	130	40	3	8	22	85	66	411 451 491	103	115	9	212 252 292	229 269 309	78	105	6	20	16
6SM71K-3000-BV 6SM71S-3000-BV 6SM71M-3000-BV	130	24	180	50	3,5	12	27	110	70	503 553 603	129	165	12	273 323 373	290 340 390	90	142	8	25	16
6SM100K-3000-BV 6SM100S-3000-BV 6SM100M-3000-BV 6SM100L-3000-BV	180	32	210	58	4	13	42	150	135	576 624 672 720	174	215	14	324 372 420 468	341 389 437 485	49	190	12	40	16

3.2.2 Radial-/axial force at the shaft end

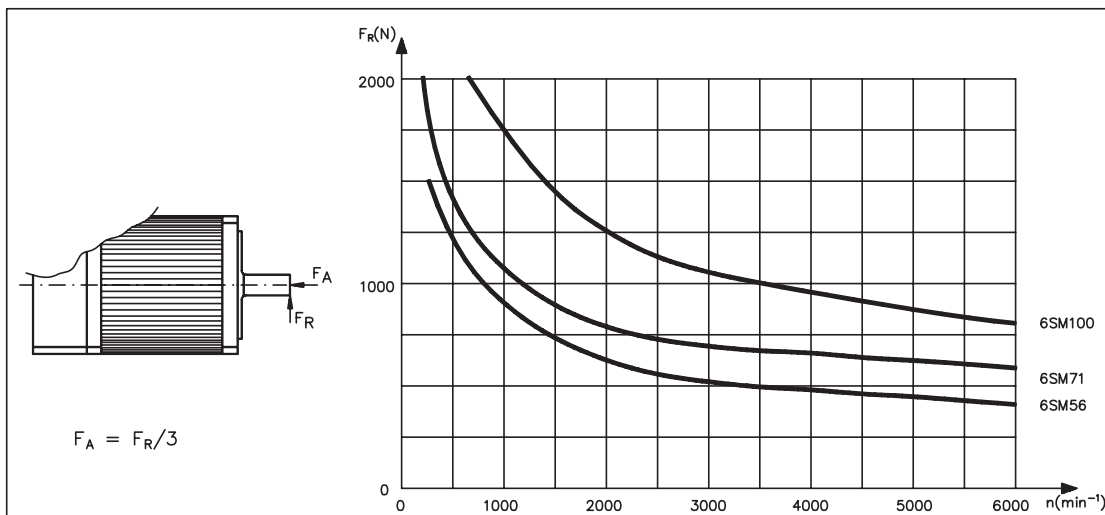

3.2.3 Wiring diagram 6SM56..100-BV

Top view
build-in plug
Resolver

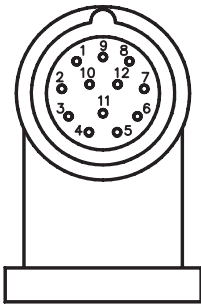

Top view
terminal box
power

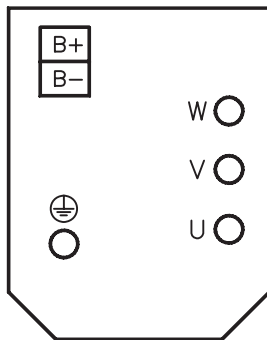

Connector ventilator

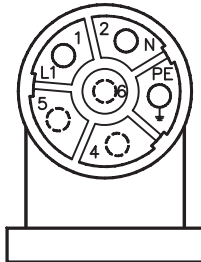

View to contacts
of build-in plug

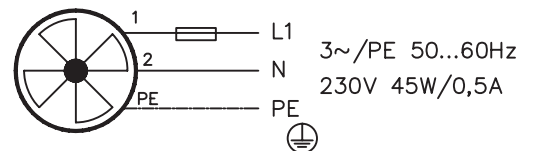

connector round, 12-poles

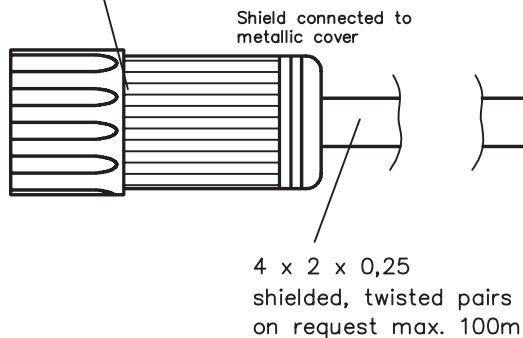

Sub-D connector 9-poles

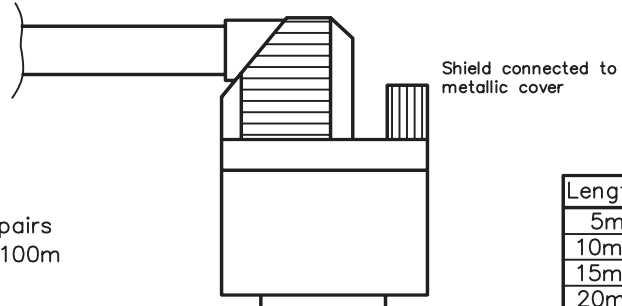

Length	Mat.No.
5m	84972
10m	84973
15m	84974
20m	84975

Colour coding acc. to IEC 757

Res. cable f. 6SM
with connector

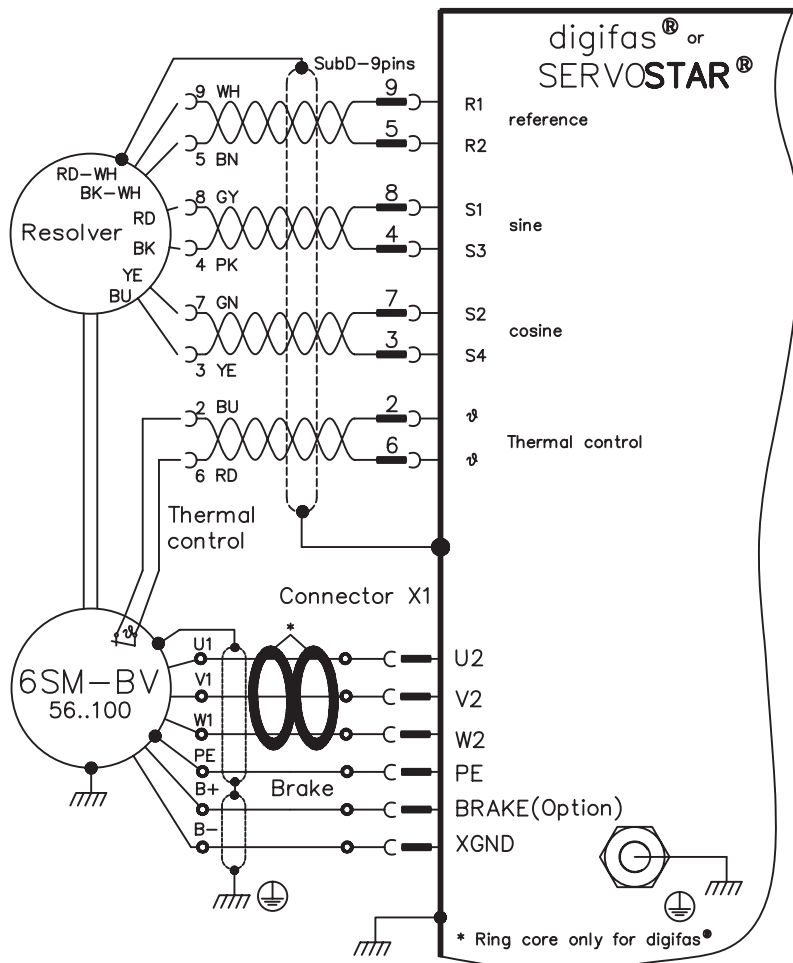

3.2.4 Fan connection

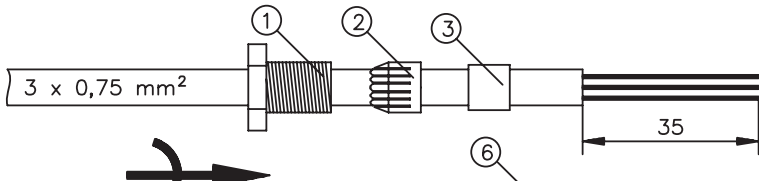

Strip off the outer insulation of the cable over a length of 35mm. Push the parts 1, 2, and 3 of the PG7 connection onto the cable.

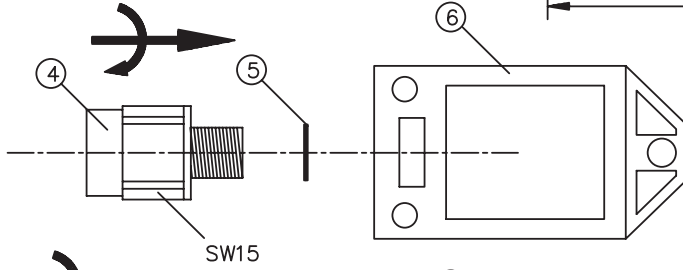

Push the O-Ring 5 onto the thread of part 4 of the PG7 connection and screw part 4 into the plug housing 6, using an open-ended spanner (15 a/f).

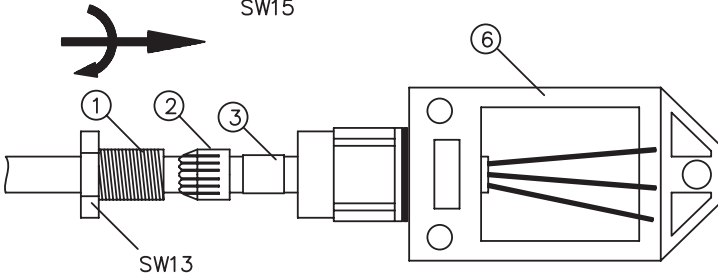

Push the rubber ring 3 into the strain relief 2. Push the cable so far through the hole into the plug housing 6 that about 1mm is visible. Screw up the PG with an open-ended spanner (13 a/f).

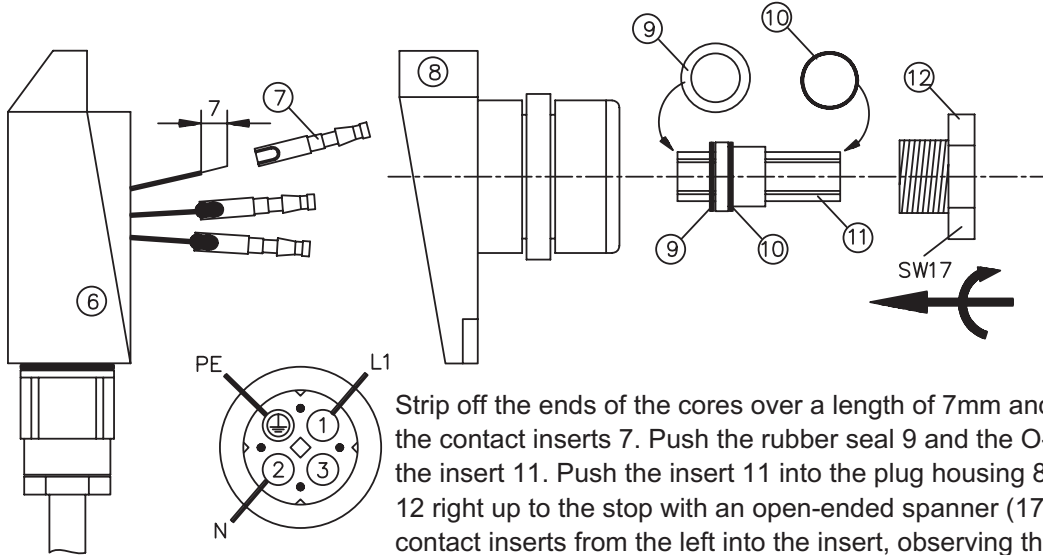

Strip off the ends of the cores over a length of 7mm and solder them to the contact inserts 7. Push the rubber seal 9 and the O-ring 10 onto the insert 11. Push the insert 11 into the plug housing 8. Screw part 12 right up to the stop with an open-ended spanner (17 a/f). Push the contact inserts from the left into the insert, observing the correct core colour (use appropriate pliers), until they snap into position

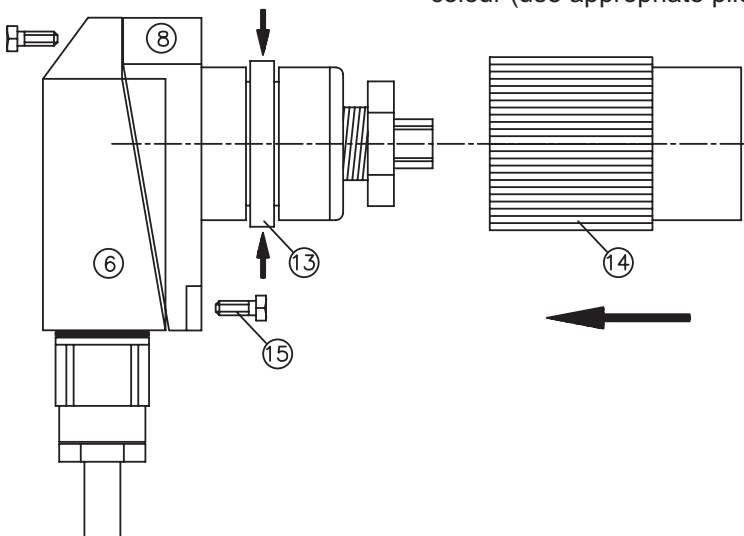

Fit parts 6 and 8 together and screw them together with the three screws 15. Compress the spring ring 13 lightly and push on the knurled sleeve 14, until it snaps into position.

3.2.5 Torque characteristics 6SM56S-3000-BV

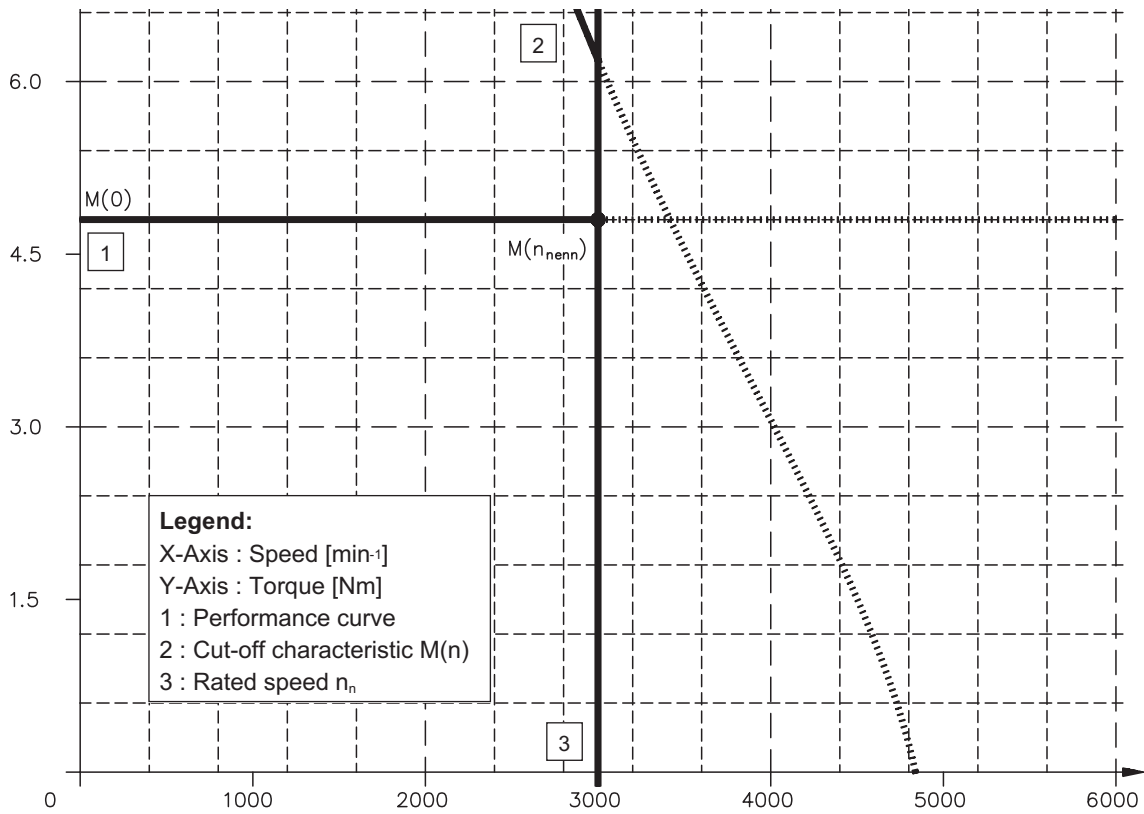

3.2.6 Torque characteristics 6SM56M-3000-BV

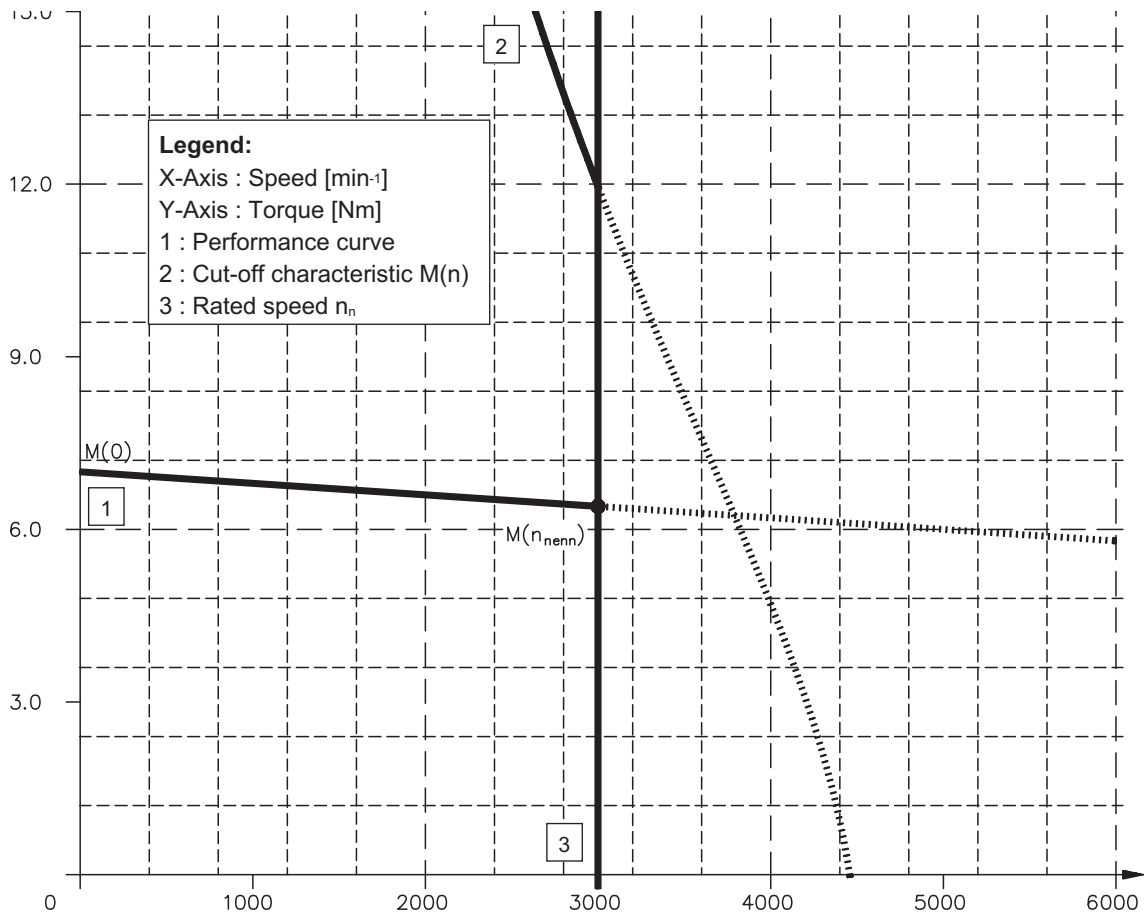

3.2.7 Torque characteristics 6SM56L-3000-BV

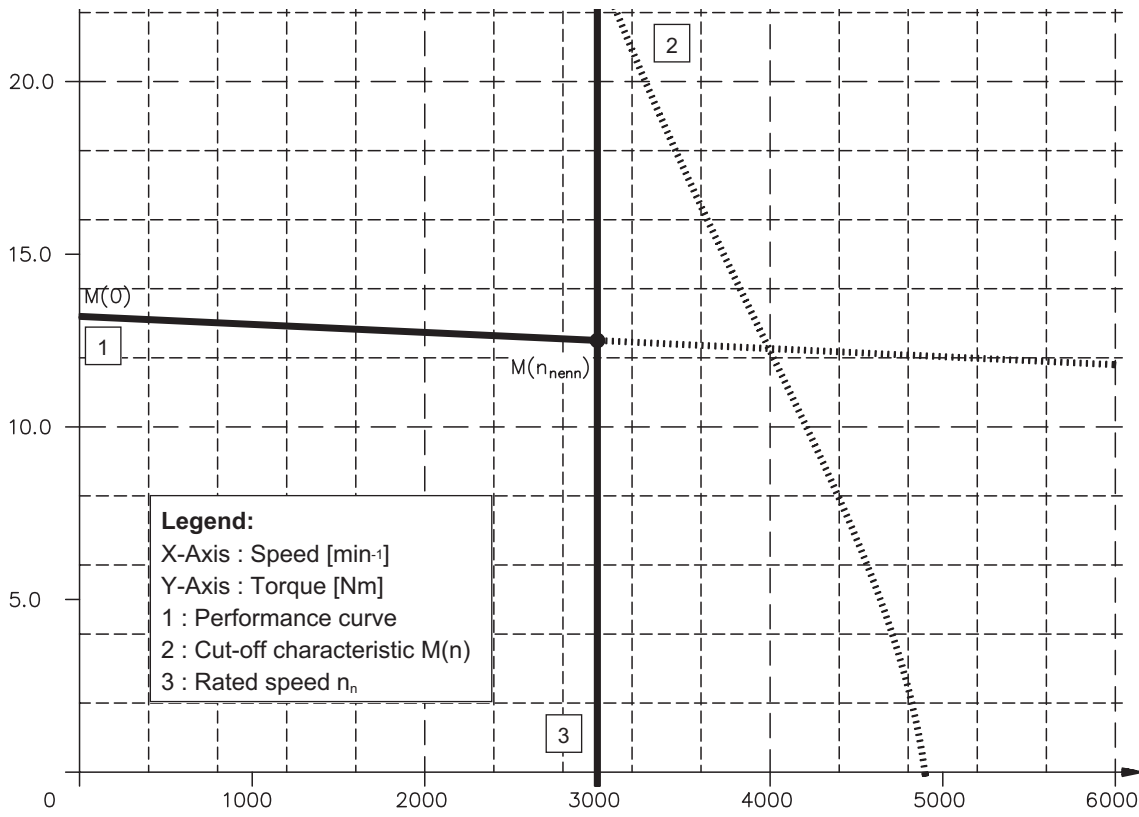

3.2.8 Torque characteristics 6SM71K-3000-BV

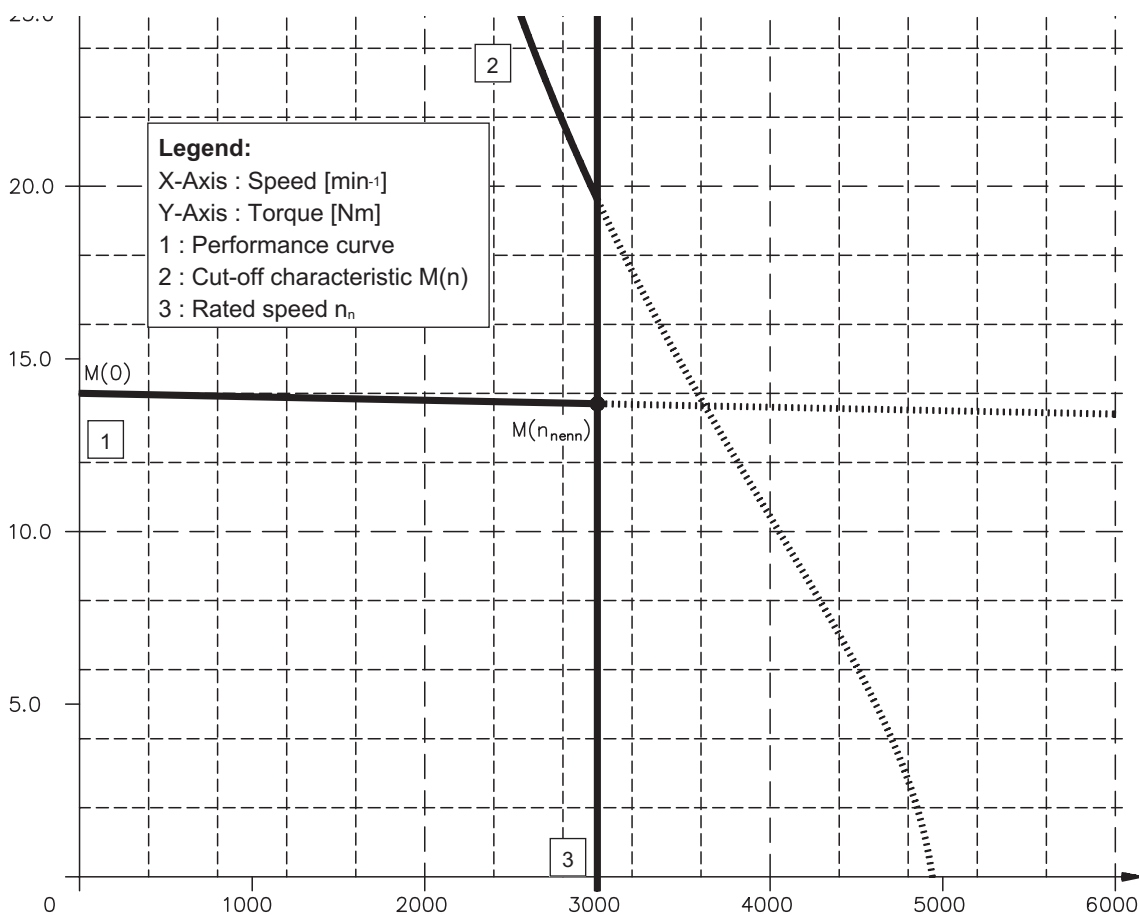

3.2.9 Torque characteristics 6SM71S-3000-BV

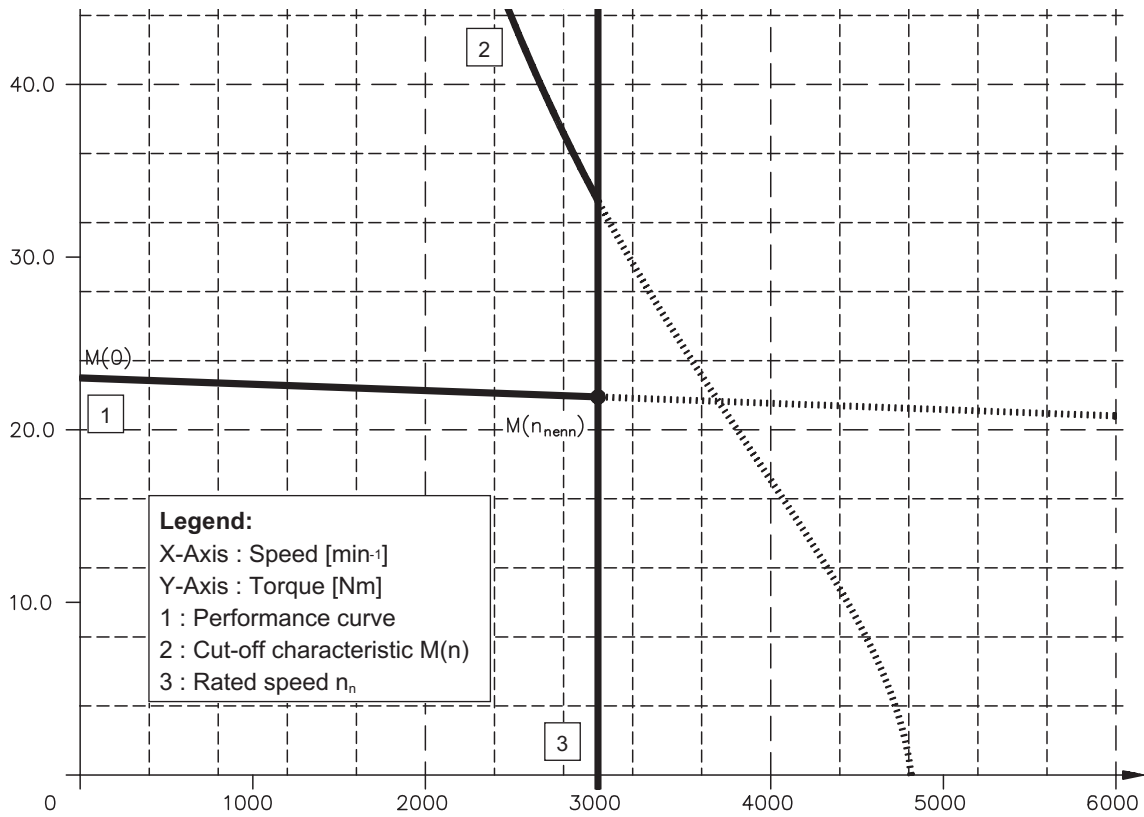

3.2.10 Torque characteristics 6SM71M-3000-BV

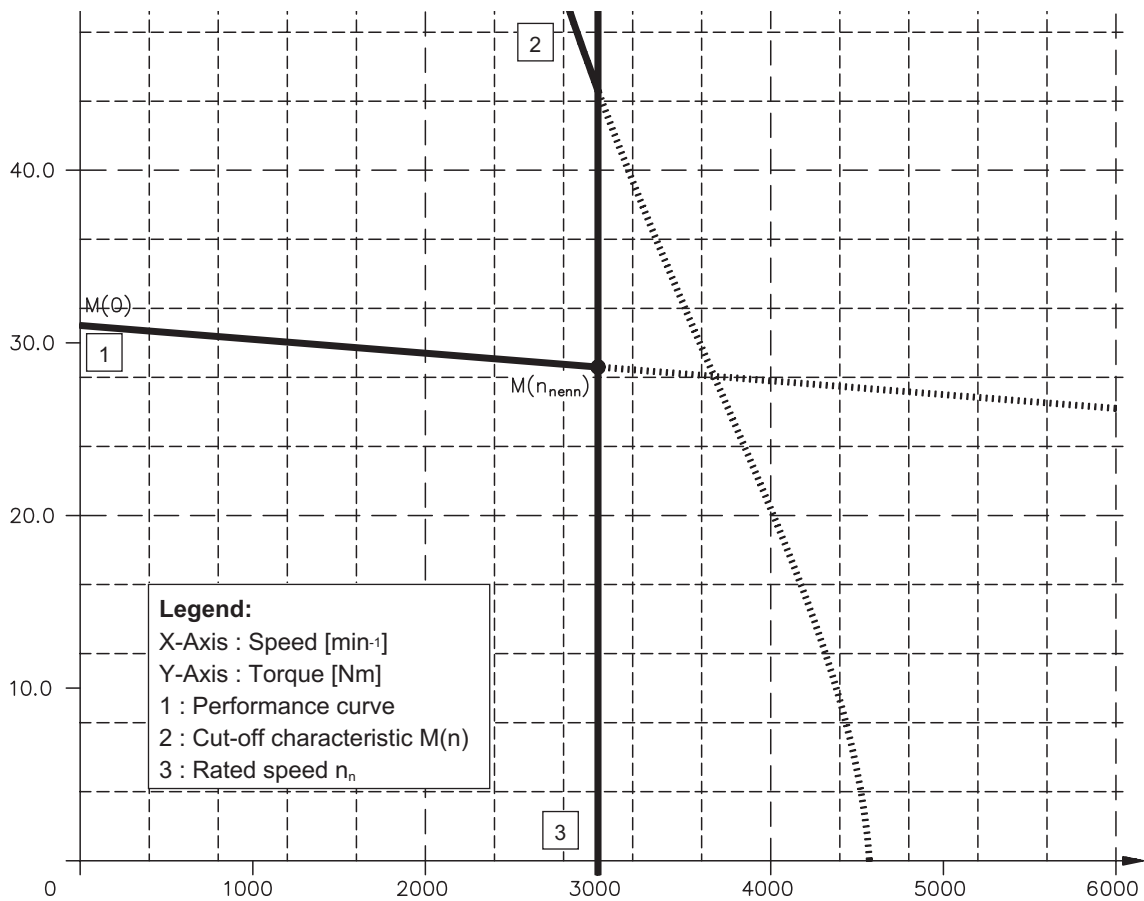

3.2.11 Torque characteristics 6SM100K-3000-BV

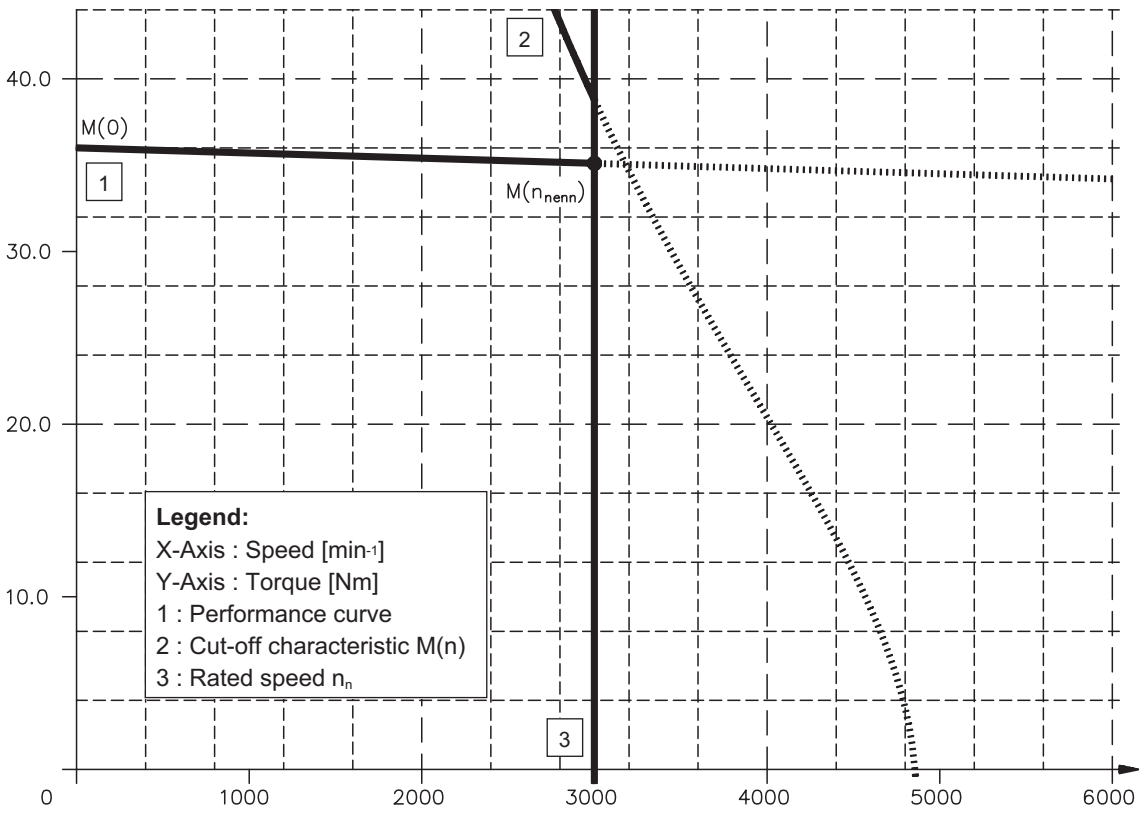

3.2.12 Torque characteristics 6SM100S-3000-BV

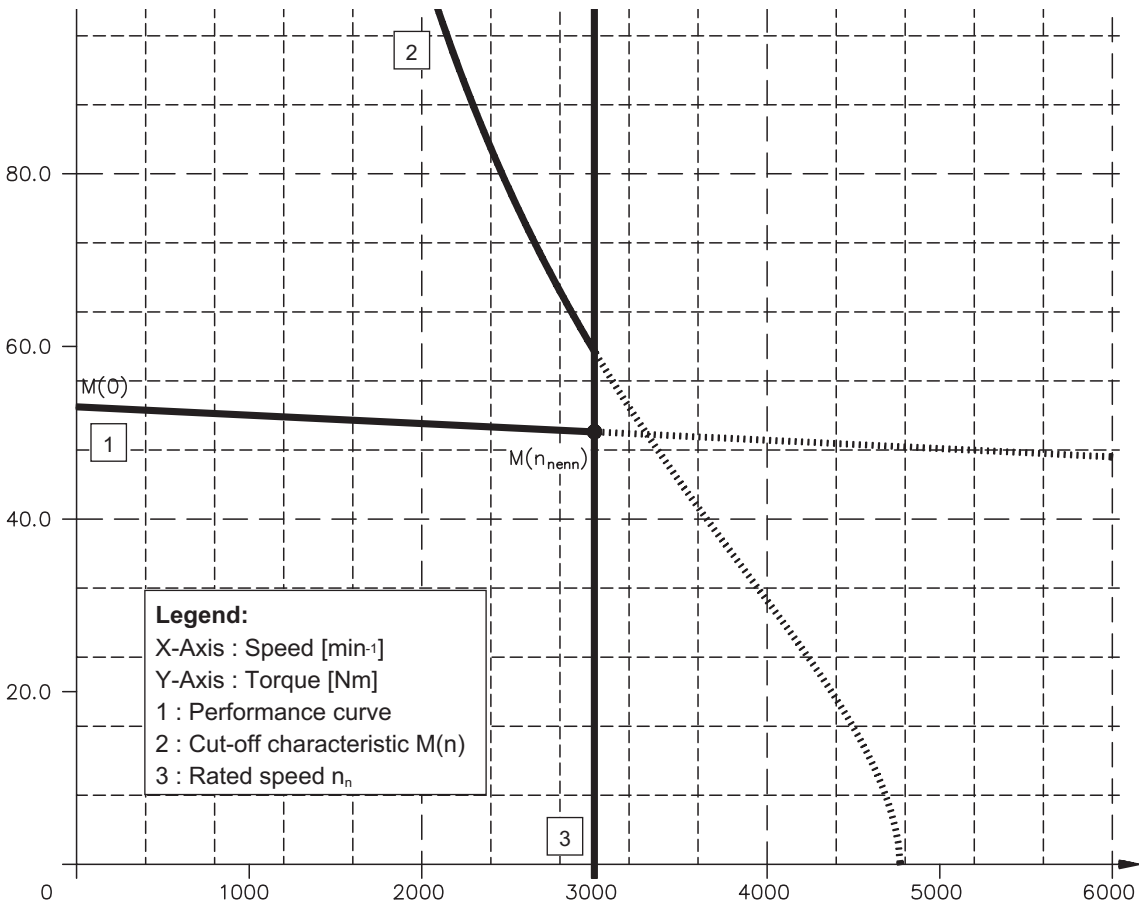

3.2.13 Torque characteristics 6SM100M-3000-BV

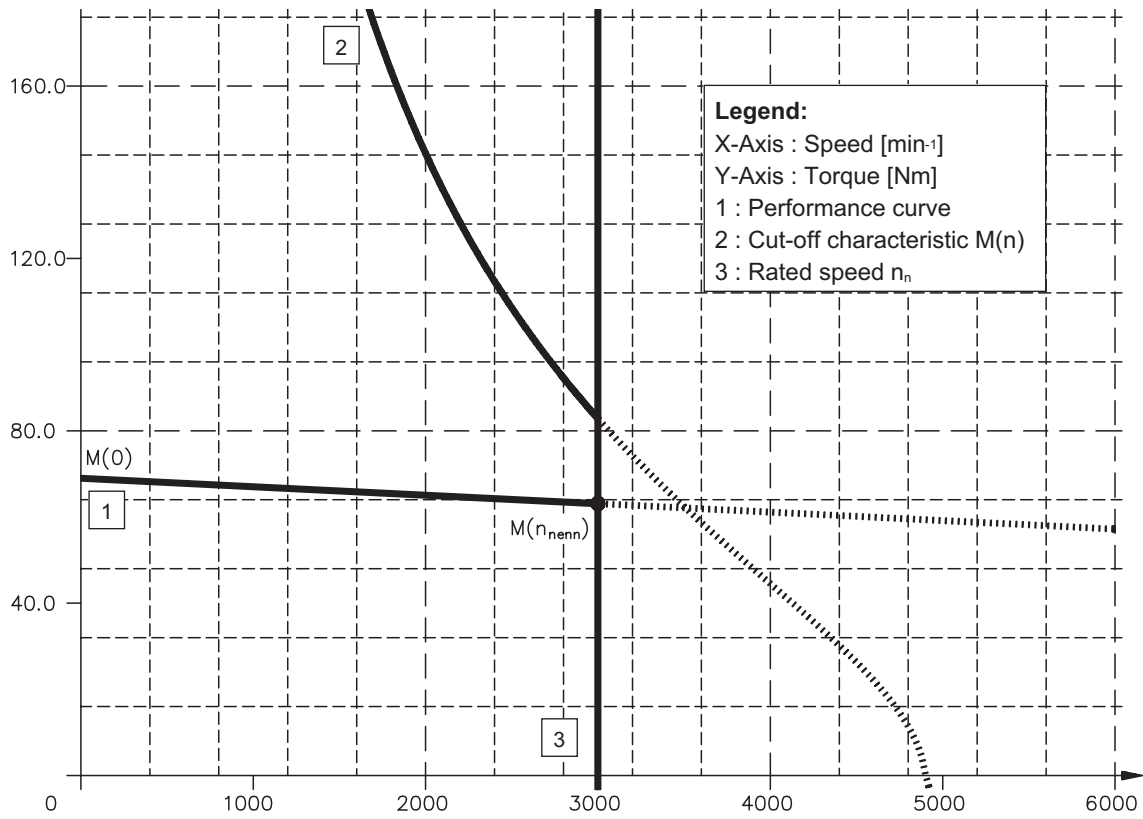

3.2.14 Torque characteristics 6SM100L-3000-BV

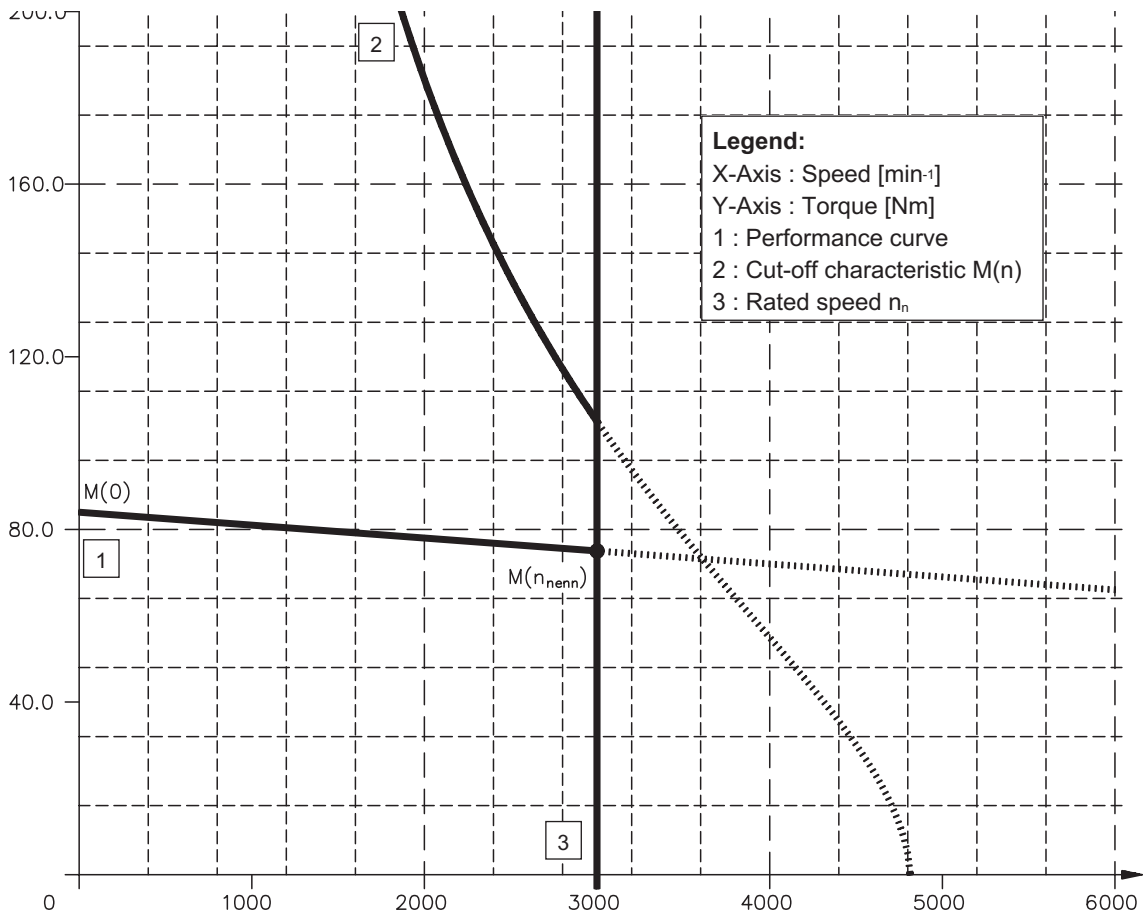

This page has been deliberately left blank

4 Appendix

4.1 Delivery package, transport, storage, maintenance, disposal

Delivery package: — Motor from the 6SM45..100 series
 — Technical description (documentation), 1 copy per delivery
 — Motor package leaflet (short info)

Transport: — Climate category 2K3 to EN 50178
 Transport temperature—25...+70°C, max. 20K/hr change
 Transport humidity rel. humidity 5% - 95% , no condensation
 — only by qualified personnel
 — only in the manufacturer's original recyclable packaging
 — avoid shocks
 — if the packaging is damaged, check the motor for visible damage.
 Inform the carrier and, if appropriate, the manufacturer.

Packaging:

Motor type	Carton	Pallet or skeleton box	Max. stacking height
6SM45	X		6
6SM56	X		6
6SM71K/71S	X		5
6SM71M		X	1
6SM100		X	1

Storage: — Climate category 1K4 to EN 50178
 Storage temperature —25...+55°C, max. variation 20K/hr.
 Humidity rel. humidity 5% - 95%, no condensation
 — only in the manufacturer's original recyclable packaging
 — max. stacking height see table under Packaging
 — Storage time unlimited

Maintenance: — Only by qualified personnel
 — The ball bearings have a grease packing which is adequate for 20,000 hours of operation under normal conditions. The bearings should be replaced after 20,000 hours of operation under rated conditions.
 — Check the motor for bearing noise every 2500 operating hours, respectively each year. If any noises are heard, then the operation of the motor must stop, the bearings must be replaced.
 — Opening the motor invalidates the warranty.

Cleaning: — If the housing is dirty: clean with Isopropanol or similar.
do not immerse or spray
 — If a separate fan is fitted: check the fan mesh for dirt twice a year.
 If necessary, clean the mesh with a brush.

Disposal: — The disposal should be carried out by a certified disposal company.
 Ask us for addresses.

4.2 Fault-finding

The following table is to be seen as a “First Aid” box. There can be a large number of different reasons for a fault, depending on the particular conditions in your system. The fault causes described below are mostly those which directly influence the motor. Peculiarities which show up in the control loop behaviour can usually be traced back to an error in the parameterization of the servo amplifier. The documentation for the servo amplifier and the operator software provides information on these matters.

For multi-axis systems there may be further hidden reasons for faults.

Our applications department can give you further help with your problems.

Fault	Possible cause	Measures to remove the cause of the fault
Motor doesn't rotate	<ul style="list-style-type: none"> — servo amplifier not enabled — Break in setpoint lead — Motor phases in wrong sequence — Brake not released — Drive is mechanically blocked 	<ul style="list-style-type: none"> — Supply ENABLE signal — Check setpoint lead — Correct the phase sequence — Check brake controls — Check mechanism
Motor runs away	<ul style="list-style-type: none"> — Motor phases in wrong sequence — ROD cable faulty or not properly plugged in (for option -IL-) 	<ul style="list-style-type: none"> — Correct the phase sequence — Check ROD/SSI cable
Motor oscillates	<ul style="list-style-type: none"> — Break in the shielding of the resolver cable — amplifier gain to high 	<ul style="list-style-type: none"> — Replace resolver cable — use motor default values
Error message: brake	<ul style="list-style-type: none"> — Short-circuit in the supply voltage lead to the motor holding brake — Faulty motor holding brake 	<ul style="list-style-type: none"> — Remove the short-circuit — Replace motor
Error message: output stage fault	<ul style="list-style-type: none"> — Motor cable has short-circuit or earth short — Motor has short-circuit or earth short 	<ul style="list-style-type: none"> — Replace cable — Replace motor
Error message: resolver	<ul style="list-style-type: none"> — Resolver connector is not properly plugged in — Break in res. cable, cable crushed or similar 	<ul style="list-style-type: none"> — Check connector — Check cables
Error message: motor temperature	<ul style="list-style-type: none"> — Motor thermostat has switched — Loose resolver connector or break in resolver cable 	<ul style="list-style-type: none"> — Wait until the motor has cooled down. Then investigate why the motor becomes so hot. — Check connector, replace resolver cable if necessary
Brake does not grip	<ul style="list-style-type: none"> — Required holding torque too high — Brake faulty — Motor shaft axially overloaded 	<ul style="list-style-type: none"> — Check the dimensioning — Replace motor — Check the axial load, reduce it. Replace motor, since the bearings have been damaged

4.3 Index

A	Ambient temperature	9	R	Radial force	10
	Assembly	19		Radial force, diagram	23
	Axial force	10		Rated current	13
	Axial force, diagram	23		Rated torque	13
B	Break response times	13		Resolver	11
C	Commissioning	21		Resolver lead	20
	Connection method	11		Rotor moment of inertia	13
	Coupling	10	S	Safety notes	6
D	Delivery package	41		Separate fan	12
	Dimensions	23		Servo amplifier	9
	Disposal	41		Shielding	19
E	Earthing	19		Site	19
F	Fan connection	34		Standstill current	13
	Feedback unit	11		Standstill torque	13
	Flange temperature	9		Storage	41
H	Holding brake	11		Storage humidity	41
I	Insulation material class	11		Storage temperature	41
M	Maintenance	41		Storage time	41
	Manufacturer declaration	8	T	Style	10
	Motor lead	20		Technical data	14
N	Nameplate	12		Thermal time constant	13
O	Options	12		Thermostat	10
P	Peak current	13		Torque constant	13
	Power derating	9		Transport	41
	Protection class	10	V	Ventilation	19
	Protective device	10		Vibration class	11
				Voltage constant	13
			W	Wiring	19
				Wiring diagram	24

Sales and Service

We are committed to quality customer service. In order to serve in the most effective way, please contact your local sales representative for assistance.
If you are unaware of your local sales representative, please contact us.

Europe

Visit the European Danaher Motion web site at www.DanaherMotion.net for Setup Software upgrades, application notes, technical publications and the most recent version of our product manuals.

Danaher Motion Customer Support - Europe

Internet www.DanaherMotion.net
E-Mail support@danahermotion.net
Phone: +49(0)203 - 99 79 - 0
Fax: +49(0)203 - 99 79 - 155

North America

Visit the North American Danaher Motion web site at www.DanaherMotion.com for Setup Software upgrades, application notes, technical publications and the most recent version of our product manuals.

Danaher Motion Customer Support North America

Internet www.DanaherMotion.com
E-Mail customer.support@danahermotion.com
Phone: (815) 226 - 2222
Fax: (815) 226 - 3148