

I/O Terminal Installation Manual



Revision 1.1, June 2011

AKT-ENC-000-000 Incremental Encoder Inputs



Keep all manuals as a product component during the life span of the product.
Pass all manuals to future users / owners of the product.

KOLLMORGEN[®]

Because Motion Matters™

Record of Document Revisions

Revision	Remarks
1.0	Preliminary edition
1.1	Added dimensions to technical data table and mechanical drawing to Appendix A. For more information, see "Technical Data" page 8 and "Appendix A" page 28 .

IMPORTANT NOTICE

Copyright© Kollmorgen™2010-2011. All rights reserved. Kollmorgen holds the copyright to this manual. All rights are reserved and no part of this publication may be reproduced or transmitted in any form or by any means without prior written consent from Kollmorgen.

Disclaimer

The information in this manual was accurate and reliable at the time of its release. However, Kollmorgen. reserves the right to change the specifications of the product described in this manual without notice at any time.

This document contains proprietary and confidential information of Kollmorgen. The contents of the document may not be disclosed to third parties, translated, copied or duplicated in any form, in whole or in part, without the express written permission of Kollmorgen.

Registered Trademarks

Kollmorgen is a registered trademark of Danaher Corp.

Technical changes which improve the performance of the device may be made without prior notice! Printed in the Federal Republic of Germany. All rights reserved. No part of this work may be reproduced in any form (by printing, photocopying, microfilm or any other method) or stored, processed, copied or distributed by electronic means without the written permission of Kollmorgen. All other proprietary names mentioned in this manual are the trademarks of their respective owners.

June 2011

1	Safety Precautions	
1.1	Safety Rules.....	5
1.2	State at Delivery.....	5
1.3	Personnel Qualification	5
1.4	Description of Notes and Warnings	5
2	Overview	
2.1	AKT-ENC-000-000 Incremental Encoder Inputs.....	6
2.1.1	Technical Data	8
2.1.2	Assignments of Terminal Contact.....	9
2.1.3	Operating Modes.....	10
2.1.4	Functions.....	10
2.1.5	LED Display	11
2.1.6	Process Data.....	11
3	Mounting and Wiring	
3.1	Installation of Bus Terminals on Mounting Rails.....	12
3.1.1	Assembly.....	12
3.1.2	Disassembly.....	12
3.1.3	Connections Within a Bus Terminal Block.....	12
3.1.4	PE Power Contact.....	13
3.1.5	Wiring	13
3.2	AKT-ENC-000-000 Connections.....	14
4	Automatic Configuration	
4.1	Scan Device	15
4.2	Setting I/O Values	15
5	Manual Configuration	
5.1	Mapping in the Bus Coupler.....	17
5.2	Control and Status Byte	18
5.2.1	Control Byte in Process Transfer	18
5.2.2	Status Byte in Process Data Transfer.....	20
5.3	Register Overview.....	21
5.4	Register Description.....	22
5.4.1	General Register Description.....	22
5.4.2	Process Variable	22
5.4.3	Type Registers	23
5.4.4	Manufacturer Parameters	24
5.4.5	User Parameters	24
5.4.6	Extended Application Region.....	25
5.5	Terminal-Specific Register Description.....	25
5.5.1	Application Parameters.....	25
5.6	Register Communication.....	26

- 5.6.1 Control Byte in Register Mode26
- Appendix A**
- A.1 I/O 12.0mm Mechanical Drawing.....28

1 SAFETY PRECAUTIONS

This chapter provides safety information for the I/O terminal.

1.1 Safety Rules

The appropriate staff must ensure that the application or use of the products described satisfy all the requirements for safety, including all the relevant laws, regulations, guidelines and standards.

1.2 State at Delivery

All the components are supplied in particular hardware and software configurations appropriate for the application. Modifications to hardware or software configurations other than those described in the documentation are not permitted, and nullify any liability from Kollmorgen.

1.3 Personnel Qualification

This description is only intended for the use of trained specialists in control and automation engineering who are familiar with the applicable national standards.

1.4 Description of Notes and Warnings

The following notes and warnings are used in this manual. They are intended to alert the reader to the associated safety instructions.

Danger — This note is intended to highlight risks for the life or health of personnel.

Warning — This note is intended to highlight risks for equipment, materials or the environment.

Note — Indicates information that contributes to better understanding.

2 OVERVIEW

This section provides an overview of the I/O terminal.

Note: For information about configuring the I/O terminal, see the Kollmorgen Automation Suite™ IDE software and online help system.

2.1 AKT-ENC-000-000 Incremental Encoder Inputs

The incremental encoder interface terminal enables the connection of any incremental encoders to the bus coupler or the PLC. A 16-bit counter with a quadrature decoder and a 16-bit latch can be read, set or activated. Besides the decoder inputs A, B, C, an additional latch input G1 (24 V) and a gate input G2 (24 V) for disabling the counter are available.

The 16-bit up / down counter mode can also be selected. In this mode of operation, input B is the counting input.

1-fold, 2-fold or 4-fold evaluation of the encoder signals A, B, C in simple or complementary form can be parameterized via the field bus.

The terminal is supplied as a 4-fold quadrature decoder with complementary evaluation of the encoder signals A, B, C. For operation of the encoder interface, the operating voltage of 24 V DC must be connected to the terminal contacts in addition to the encoder inputs.

Additional features include:

- The incremental encoder with fault alarm outputs can be connected to the Status input of the AKT-ENC-000-000.
- A period measurement with a resolution of 200 ns can also be performed.

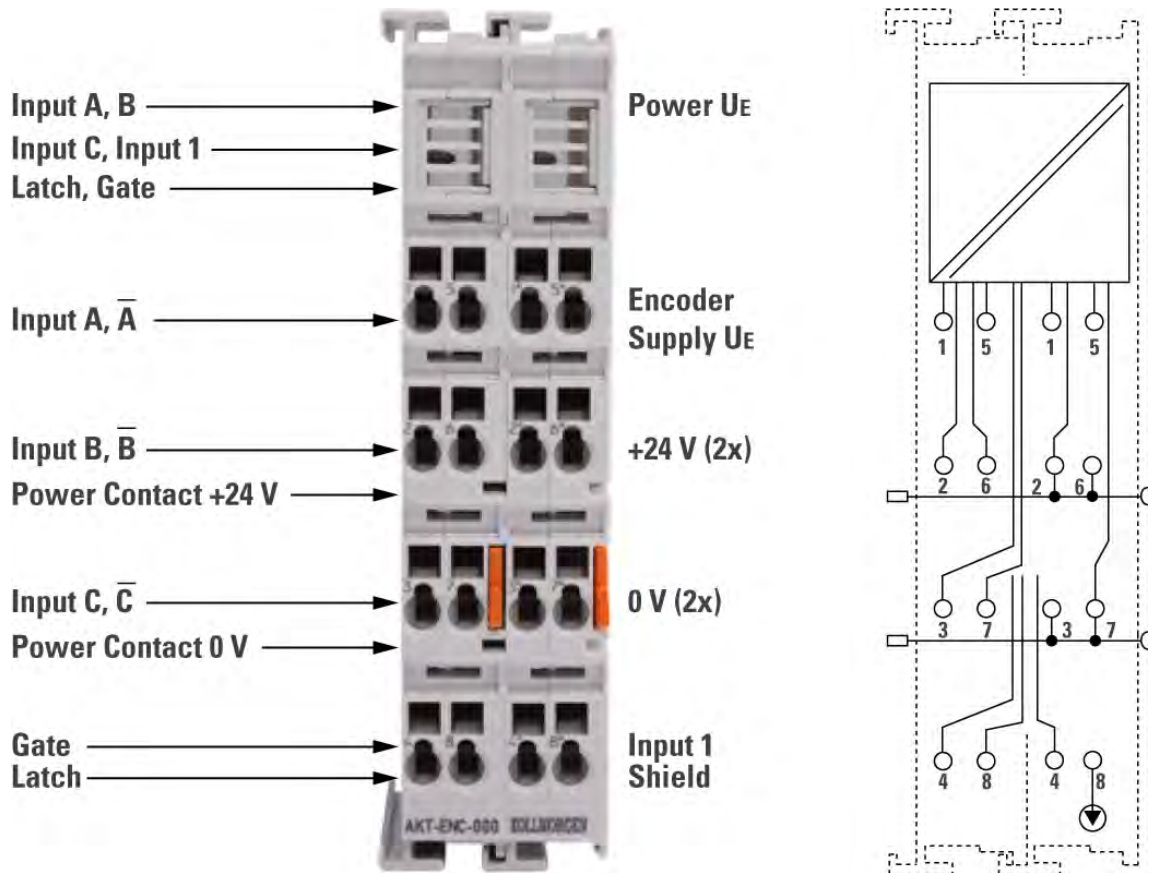

Figure 2.1 Top View and Contact Assembly

2.1.1 Technical Data

This section provides the technical details for the 2-channel thermocouple module.

Parameters	AKT-ENC-000-000
Sensor connection	A, A(inv), B, B(inv), zero, zero(inv), difference signal (RS 485); Status input
Sensor operating voltage	5 V DC
Sensor output current	0.5 A
Counter	16 bits binary
Cut off frequency	1 MHz (at 4 time evaluation)
Quadrature decoder	1-2-4 time evaluation
Zero pulse latch	16 bits
Commands	Read, set, activate
Supply voltage	24 V DC (20 V ... 29 V)
Current consumption from power contacts	0.1 A (without sensor load current)
Bit width in the process image	I/O: 2 x 16 bits data, 1 x 8 bits control/status
Current consumption from Standard-Bus	25 mA
Weight	~85 g
Dimensions (W x H)	~12 mm x 100 mm
Permissible ambient temperature range during operation	0°C ... +55°C
Permissible ambient temperature range during storage	-25°C ... +85°C
Relative humidity	95%, no condensation
Vibration / Shock resistance	Conforms to EN 60068-2-6 / EN 60068-2-27, EN 60068-2-29
EMC resistance burst / ESD	Conforms to EN 61000-6-2 / EN 61000-6-4
Installation position	Any
Type of protection	IP20

2.1.2 Assignments of Terminal Contact

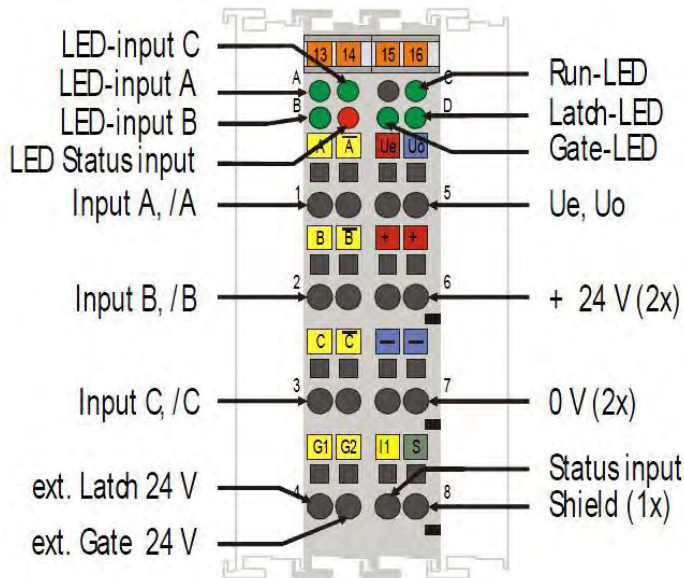

Inputs A, /A

Pulse input in the terminal's encoder and counter mode.

Inputs B, /B

Phase-shifted pulse input in the terminal's encoder mode.

Counting direction input in the terminal's counter mode.
Counting direction:

- + 5 V (or open contact): up
- 0 V: down

Inputs C, /C

Zero point pulse input for the terminal's latch register.

This input is activated via the EN_LATC bit in the terminal's control byte.

External Latch 24 V

Additional latch input of the terminal.

The counter value is latched when this input is alerted and an edge change takes place from 0 V to 24 V.

External Gate 24 V

A high level at this contact suppresses counting by the terminal.

Status Input 5 V

Incremental encoder with fault alarm outputs can be connected to the Status input of the AKT-ENC-000-000.

Ue

Voltage supply for the encoder (+5 V).

Uo

Voltage supply for the encoder (0 V).

0 V, 24 V

A supply of 0 V and 24 V voltage must be applied to these contacts for operation of the terminal.

2.1.3 Operating Modes

A, B, zero pulse incremental encoder (default)
Up/down counter with:

- A = Count , the positive edges of the input pulses are counted
- B = Up/down input
 - B = 0: up counting direction
 - B = 1: down counting direction
- C = Gate input
 - C = 0: counter enabled
 - C = 1: counter disabled

2.1.4 Functions

- Counting
- Counter setting
- Arming the zero pulse and storing the valid value
- Determining the period between two pulses with a resolution of two 200 ns (the time between two positive edges of the input signal A is evaluated)
- Indication of a counter overflow or underflow.

2.1.5 LED Display

The signal LEDs indicate the status of the encoder inputs A, B, C, Status input and of the logic inputs of the gate and of the additional external latch.

- The RUN LED indicates cyclic data transfer with the higher-level controller.
- The RUN LED goes off if no process data is exchanged for 100 ms.

2.1.6 Process Data

The AKT-ENC-000-000 always occupies 6 bytes of input data and 6 bytes of output data. The control / status byte is at the least significant byte offset.

The data word D0/D1 contains the counter value (read/set) and the data word D3/D4 contains the latch word (read).

In the period measurement mode the value can be found in D2 together with D3 and D4.

3 MOUNTING AND WIRING

This section provides mounting and wiring information for the operator terminal.

Note: For information about configuring the I/O terminal, see the Kollmorgen Automation Suite™ IDE software and online help system.

3.1 Installation of Bus Terminals on Mounting Rails

DANGER!! Bring the bus terminal system into a safe, powered down state before starting installation, disassembly or wiring of the Bus Terminals!

3.1.1 Assembly

The Bus Coupler and Bus Terminals are attached to commercially available 35 mm mounting rails (DIN rails according to EN 50022) by applying slight pressure:

1. First attach the Fieldbus Coupler to the mounting rail.
2. The Bus Terminals are now attached on the right-hand side of the Fieldbus Coupler. Join the components with tongue and groove and push the terminals against the mounting rail, until the lock clicks onto the mounting rail.

If the Terminals are clipped onto the mounting rail first and then pushed together without tongue and groove, the connection will not be operational! When correctly assembled, no significant gap should be visible between the housings.

During the installation of the Bus Terminals, the locking mechanism of the terminals must not come into conflict with the fixing bolts of the mounting rail.

3.1.2 Disassembly

Each terminal is secured by a lock on the mounting rail, which must be released for disassembly:

1. Carefully pull the orange-colored lug approximately 1 cm out of the disassembled terminal, until it protrudes loosely. The lock with the mounting rail is now released for this terminal, and the terminal can be pulled from the mounting rail without excessive force.
2. Grasp the released terminal with thumb and index finger simultaneous at the upper and lower grooved housing surfaces and pull the terminal away from the mounting rail.

3.1.3 Connections Within a Bus Terminal Block

The electric connections between the Bus Coupler and the Bus Terminals are automatically realized by joining the components:

- The six spring contacts of the Standard Bus/Performance Bus deal with the transfer of the data and the supply of the Bus Terminal electronics.
- The power contacts deal with the supply for the field electronics and thus represent a supply rail within the bus terminal block. The power contacts are supplied via terminals on the Bus Coupler.

Note: During the design of a bus terminal block, the pin assignment of the individual Bus Terminals must be taken account of, since some types (e.g. analog Bus Terminals or digital 4-channel Bus Terminals) do not or not fully loop through the power contacts. Power Feed Terminals interrupt the power contacts and thus represent the start of a new supply rail.

3.1.4 PE Power Contact

The power contact labeled PE can be used as a protective earth. For safety reasons this contact mates first when plugging together, and can ground short-circuit currents of up to 125 A.

WARNING!! Note that, for reasons of electromagnetic compatibility, the PE contacts are capacitatively coupled to the mounting rail. This may lead to incorrect results during insulation testing or to damage on the terminal (e.g. disruptive discharge to the PE line during insulation testing of a consumer with a nominal voltage of 230 V).

For insulation testing, disconnect the PE supply line at the Bus Coupler or the Power Feed Terminal! In order to decouple further feed points for testing, these Power Feed Terminals can be released and pulled at least 10 mm from the group of terminals.

Note: The PE power contact must not be used for other potentials!

3.1.5 Wiring

Up to eight connections enable the connection of solid or finely stranded cables to the Bus Terminals. The terminals are implemented in spring force technology. Connect the cables as follows:

1. Open a spring-loaded terminal by slightly pushing with a screwdriver or a rod into the square opening above the terminal.
2. The wire can now be inserted into the round terminal opening without any force.
3. The terminal closes automatically when the pressure is released, holding the wire securely and permanently.

Note: Analog sensors and actors should always be connected with shielded, twisted paired wires.

3.2 AKT-ENC-000-000 Connections

The section describes the connections for the Counter module.

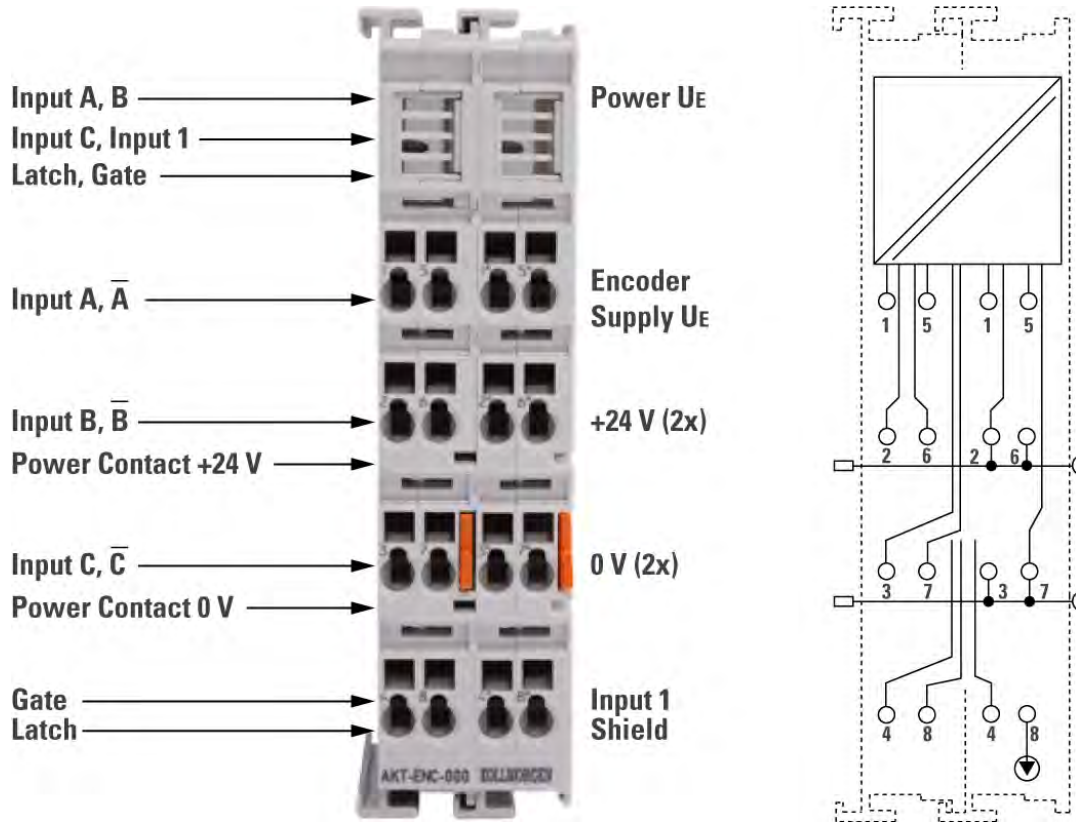

Figure 3.1 Terminal Connections

4 AUTOMATIC CONFIGURATION

This chapter describes the basics of automatic configuration within the KAS Integrated Development Environment (IDE).

4.1 Scan Device

For ease-of-use the KAS IDE Scan Device feature provides automatic integration of I/O devices. This allows you to automatically locate and add I/O terminals to the application project:

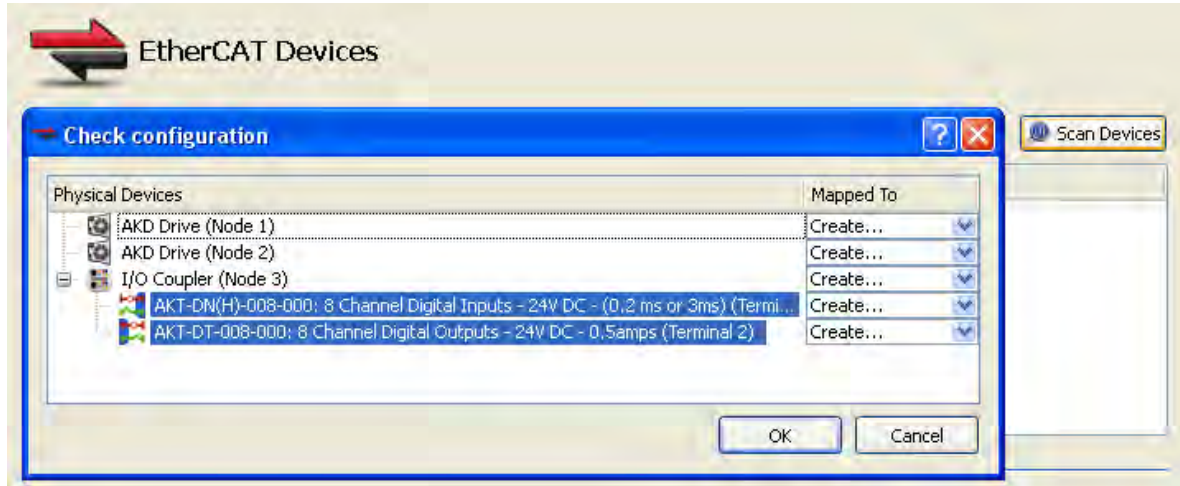

4.2 Setting I/O Values

After the I/O slice is mapped it can be selected in the application project and the offset and gain values can be set. Additionally, the IDE allows you to map the I/O points to variables in your application:

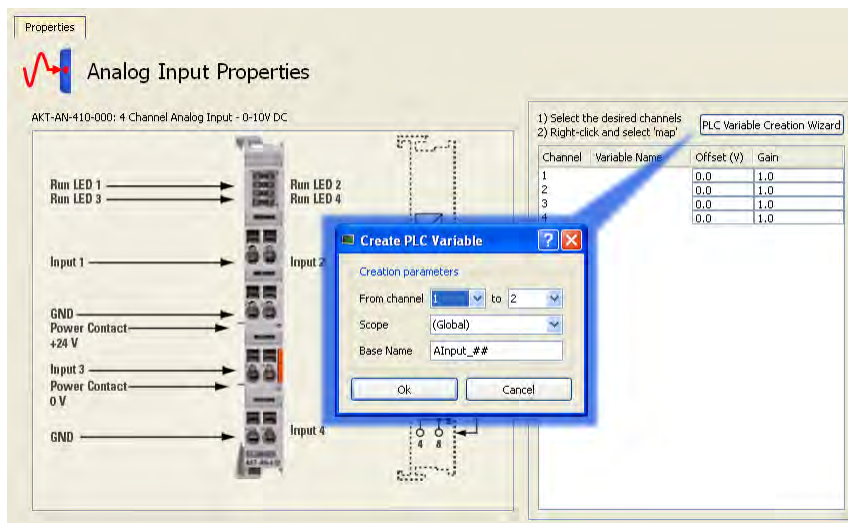

For more detailed information on these procedures refer to the section “EtherCAT Scan Device” in the KAS IDE online help.

5 MANUAL CONFIGURATION

Kollmorgen strongly recommends automatic configuration using the KAS IDE over manual configuration. For automatic configuration refer to chapter 4. Manual configuration is for advanced procedures only. The following sections provide the necessary configuration information to manually map the I/O device.

5.1 Mapping in the Bus Coupler

Each terminal channel is mapped in the bus coupler. In the standard case, this mapping is done with the default setting in the bus coupler / bus terminal. The following tables provide information on how the AKT-ENC-000-000 maps itself in the bus coupler depending on the set parameters.

The AKT-ENC-000-000 is mapped in the bus coupler depending on the set parameters. The terminal is always evaluated completely, the terminal occupies memory space in the process image of the input and outputs.

Default mapping for CANopen

Conditions	Word offset	High byte	Low byte
Complete evaluation: any Motorola format: no Word alignment: no	0	D0	CB/SB
	1	D2	D1
	2	D4	D3

Default mapping for Profibus Coupler

Conditions	Word offset	High byte	Low byte
Complete evaluation: any Motorola format: yes Word alignment: no	0	D1	CB/SB
	1	D2	D0
	2	D3	D4

Default mapping for EtherCAT

Conditions	Word offset	High byte	Low byte
Complete evaluation: any Motorola format: no Word alignment: yes	0	–	CB/SB
	1	D1	D0
	2	–	D2
	3	D4	D3

Conditions	Word offset	High byte	Low byte
Complete evaluation: any Motorola format: yes Word alignment: yes	0	–	CB/SB
	1	D0	D1
	2	–	D2
	3	D3	D4

Key Complete evaluation: The terminal is mapped with control / status byte.

Motorola format: The Motorola or Intel format can be set.

Word alignment: The terminal is at a word limit in the bus coupler.

CB: Control- Byte (appears in the process image of the outputs).

SB: Status- Byte (appears in the process image of the inputs).

D0/D1: Counter word (read/set)

(D2): contains the period, together with 3/D4

D3/D4: Latch word (read)

5.2 Control and Status Byte

The following section describes the control and status bytes.

5.2.1 Control Byte in Process Transfer

The control byte is transferred from the controller to the terminal. It can be used in the register mode (REG = 1) or in process data transfer (REG = 0). Various actions are triggered in the AKT-ENC-000-000 with the control byte:

Bit name	7	6	5	4	3	2	1	0
	REG = 0	-	-	-	En_Latch_Ext_n	Cnt_Set	EN_LAT_EXT/ RD_PERIOD	EN_LATC

Bit	Bit	Function
3	En_Latch_Ext_n	The external latch input is activated for negative edge. With the first external latch impulse after validity of the EN_Latch_Ext_n bit, the counter value in the latch register is stored. The pulses that follow have no influence on the latch register when the bit is set. Attention must be paid to ensuring that the corresponding latch valid bit (Latch_Ext_Val) has been removed from the terminal before alerting of the zero pulse. This functionality is

Bit	Bit	Function
		adjustable in the feature register (default).
2	Cnt_Set	The counter is set to the value that is specified via the process data with the rising edge of Cnt_Set.
1	En_Latch_Ext	The external latch input is activated for positive edge. With the first external latch impulse after validity of the En_Latch_Ext bit, the counter value in the latch register is stored. The pulses that follow have no influence on the latch register when the bit is set. Attention must be paid to ensuring that the corresponding latch valid bit (Latch_Ext_Val) has been removed from the terminal before alerting of the zero pulse. This functionality is adjustable in the feature register (default).
	RD_Period	The periods between two positive edges of the input A are measured with a resolution of 200 ns. When the bit is set, this period is output in the data bytes D2, D3, D4. This functionality is adjustable in the feature register.
0	En_Latch	The zero point latch (C input) is activated. The counter value is stored in the latch register with the first external latch pulse after validity of the En_Latch bit (this has priority over En_Latch_Ext). The pulses that follow have no influence on the latch register when the bit is set. Attention must be paid to ensuring that the corresponding latch valid bit (Latch_Val) has been removed from the terminal before the zero pulse is alerted (the Latch_Val bit cannot be removed from the terminal until the C pulse has a low level).

Note: For the external latch input: The activation of the positive edge (En_Latch_Ext = 1) has priority to the activation of the negative edge (En_Latch_Ext_n = 1).

5.2.2 Status Byte in Process Data Transfer

The status byte is transferred from the terminal to the controller. The status byte contains various status bits of the AKT-ENC-000-000.

Bit name	7	6	5	4	3	2	1	0
	REG = 0	-	State_Input	Overflow	Underflow	Cnt_Set_Acc	Latch_Ext_Val/RD_Period_Q	Latch_Val

Bit	Name	
5	State_Input	The state of the Status input is mapped in this Bit (adjustable via feature register)
4	Overflow	This bit is set if an overflow (65535 to 0) of the 16-bit counter occurs. It is reset when the counter exceeds a third of the measurement range (21845 to 21846) or as soon as an underflow occurs.
3	Underflow	This bit is set if an underflow (0 to 65535) of the 16-bit counter occurs. It is reset when the counter drops below two thirds of the measurement range (43690 to 43689) or as soon as an overflow occurs.
2	CntSet_Acc	The data for setting the counter has been accepted by the terminal.
1	RD_Period_Q	The data bytes 2, 3, 4 contain the period time
	Latch_Ext_Val	An external latch pulse has occurred. The data D2,D3 in the process image corresponds to the latched value when the bit is set. To activate the latch input again, En_Latch_Ext must first be removed and then set again.
0	Latch_Val	A zero point latch has occurred. The data D2, D3 in the process image corresponds to the latched value when the bit is set. To activate the latch input again, En_Latch must first be removed and then set again.

5.3 Register Overview

The terminal can be configured and parameterized by using the internal register structure.

Address	Description	Default Value	R/W	Storage Medium
R0	Reserved	0x0000	R	
...
R5	Reserved	0x0000	R	
R6	Diagnostic register – not used	0x0000	R	
R7	Command register - not used	0x0000	R	
R8	Terminal type	5101	R	ROM
R9	Software version number	0x????	R	ROM
R10	Multiplex shift register	0x0218/0130	R	ROM
R11	Signal channels	0x0130	R	ROM
R12	Minimum data length	0x3030	R	ROM
R13	Data structure	0x0000	R	ROM
R14	Reserved	0x0000	R	
R15	Alignment register	Variable	R/W	RAM
R16	Hardware version number	0x????	R/W	SEEROM
R17	Reserved			
...
R31	Code word register	Variable	R/W	RAM
R32	Feature register	0x2200	R/W	SEEROM
R33	Reserved	0x0000	R/W	SEEROM
...
R61	Reserved	0x0000	R/W	SEEROM

5.4 Register Description

The complex terminals can be adjusted to different operating modes or functionalities. The " general description of register " describes the contents of the registers, which are identical for all complex terminals.

The terminal-specific registers are explained in the following section following.

The access to the internal registers of the terminal is described in the section "Register Communication ".

5.4.1 General Register Description

Complex terminals that possess a processor are capable of bidirectionally ex-changing data with the higher-level control system. Below, these terminals are referred to as intelligent bus terminals. They include the analog inputs (0-10V, -10-10V, 0-20mA, 4-20mA), the analog outputs (0-10V, -10-10V, 0-20mA, 4-20mA), serial interface terminals (RS485, RS232, TTY, data transfer terminals), counter terminals, encoder interfaces, SSI interfaces, PWM terminals and all other configurable terminals.

Internally, all intelligent terminals possess a data structure that is identical in terms of it's essential characteristics. This data area is organized in words and embraces 64 memory locations. The essential data and parameters of the terminal can be read and adjusted by way of the structure. Function calls with corresponding parameters are also possible. Each logical channel of an intelligent terminal has such a structure (therefore, 4-channel analog terminals have 4 register sets).

This structure is broken down into the following areas:

Register	Application
0 to 7	Process variables
8 to 15	Type register
16 to 30	Manufacturer parameters
31 to 47	User parameters
48 to 63	Extended user area

5.4.2 Process Variable

R0 - R7: Registers in the terminal's internal RAM – The process variables can be used in addition to the actual process image and their functions are specific to the terminal.

R0 - R5: These registers have a function that depends on the terminal type.

R6: Diagnostic register – The diagnostic register may contain additional diagnostic information. In the case of serial interface terminals, for example, parity errors that have occurred during data transfer are indicated.

R7: Command register

High-Byte_Write = function parameter

Low-Byte_Write = function number

High-Byte_Read = function result

Low-Byte_Read = function number

5.4.3 Type Registers

R8 - R15 Registers in the terminal's internal ROM

The type and system parameters are programmed permanently by the manufacturer and can only be read by the user but cannot be modified.

R8: Terminal type:

The terminal type in register R8 is needed to identify the terminal.

R9: Software version X.y

The software version can be read as an ASCII character string.

R10: Data length

R10 contains the number of multiplexed shift registers and their length in bits. The bus coupler recognizes this structure.

R11: Signal channels

In comparison with R10, the number of logically existing channels is located here. For example, one physically existing shift register may consist of several signal channels.

R12: Minimum data length

The respective byte contains the minimum data length of a channel to be transferred. If the MSB is set, then the control/status byte is not necessarily needed for the function of the terminal and, with appropriate configuration of the coupler, is not transferred to the control system. 3.2.1.1

R13: Data type register

Data Type Register	Description
0x00	Terminal with no valid data type
0x01	Byte array
0x02	Structure 1 byte n bytes
0x03	Word array

Data Type Register	Description
0x04	Structure 1 byte n words
0x05	Double word array
0x06	Structure 1 byte n double words
0x07	Structure 1 byte 1 double word
0x08	Structure 1 byte 1 double word
0x11	Byte array with variable logical channel length
0x12	Structure 1 byte n bytes with variable logical channel length (e.g. 60xx)
0x13	Word array with variable logical channel length
0x14	Structure 1 byte n words with variable logical channel length
0x15	Double word array with variable logical channel length
0x16	Structure 1 byte n double words with variable logical channel length

R14: Reserved

R15: Alignment bits (RAM) – The alignment bits are used to place the analog terminal in the Bus Coupler on a byte boundary.

5.4.4 Manufacturer Parameters

R16 to R30: Manufacturer parameter area (SEEROM) – The manufacturer parameters are specific for each type of terminal. They are programmed by the manufacturer, but can also be modified by the controller. The manufacturer parameters are stored in a serial EEPROM in the terminal, and are retained in the event of voltage drop-out. These registers can only be altered after a code-word has been set in R31.

5.4.5 User Parameters

R31 to R47: User parameter area (SEEROM) – The application parameters are specific for each type of terminal. They can be modified by the programmer. The application parameters are stored in a serial EEPROM in the terminal, and are retained in the event of voltage drop-out. The user area is write-protected by a code-word.

R31: Code-word register in RAM – The code-word **0x1235** must be entered here so that parameters in the user area can be modified. If any other value is entered into this register, the write-protection is active. When write protection is not active, the code word is returned when the register is read. If the write protection is active, the register contains a zero value.

R32: Feature register – This register specifies the terminal's operating modes. Thus, for instance, a user-specific scaling can be activated for the analog I/Os.

R33 to R47 Terminal-specific Registers – The function of these registers depends on the respective terminal type (see terminal-specific register description).

5.4.6 Extended Application Region

R47 to R63 – These registers have not yet been implemented.

5.5 Terminal-Specific Register Description

This section contains the description for terminal specific registers.

5.5.1 Application Parameters

R32: Feature register:

[0x2200]

The feature register determines the operating modes of the terminal.

Feature bit no.		Mode Description
Bit 0	0	Reserved, don't change
Bit 1	0/1	0: Counter inhibit with high-level at Gate input [0] 1: Counter inhibit with low-level at Gate-input
Bit 3, Bit 2	0 0	Status input (active-low) is mapped into the status-byte.5 (ST.5) [00]
	0 1	Reserved
	1 0	ST.5 = Status input, ST.6 = Status input
	1 1	ST.5 = Status input, ST.6 = Status input
Bit 6 – Bit 4	0 0 0	External Latch function active [000]
	0 0 1	Period measurement active
	0 1 0	Reserved
	... 1 1 1	
Bit 7 – 9	0	Reserved, don't change
Bit 11, Bit 10	0 0	4-fold evaluation of the encoder signals A,B,C, i.e. both rising and falling edges of the encoder signals A, B are counted. [00]
	0 1	1-fold evaluation of the encoder signals A, B, C. i.e. every period of the encoder signal A is counted.
	1 0	2-fold evaluation of the encoder signals A, B, C, i.e. every edge of the encoder signal A is counted.

Feature bit no.		Mode Description
	1 1	4-fold evaluation of the encoder signals A, B, C
Bit 14 – 12	0	Reserved, don't change
Bit 15	0/1	0: Encoder interface. [0] 1: Counter mode is activated. 16-bit up/down counter Input A: Counter Input B: Counting direction (5 V or open = up, 0 V= down) Input C: Latch

5.6 Register Communication

Register Access Via Process Data Exchange | Bit 7=1_{bin}: Register Mode

If bit 7 of the control byte is set, then the first two bytes of the user data are not used for exchanging process data, but are written into or read from the terminal's register set.

Bit 6=0_{bin}: read | Bit 6=1_{bin}: write

Bit 6 of the control byte specifies whether a register should be read or written. If bit 6 is not set, then a register is read out without modifying it. The value can then be taken from the input process image.

If bit 6 is set, then the user data is written into a register. As soon as the status byte has supplied an acknowledgement in the input process image, the procedure is completed (see example).

Bit 0 to 5: Address

The address of the register that is to be addressed is entered into bits 0 to 5 of the control byte.

5.6.1 Control Byte in Register Mode

Bit name	7	6	5	4	3	2	1	0
	REG = 0	W/R	A5	A4	A3	A2	A1	A0

REG = 0_{bin}: Process data exchange

REG = 1_{bin}: Access to register structure

W/R = 0_{bin}: Read register

W/R = 1_{bin}: Write register

A5...A0 = register address

Address bits A5 to A0 can be used to address a total of 64 registers.

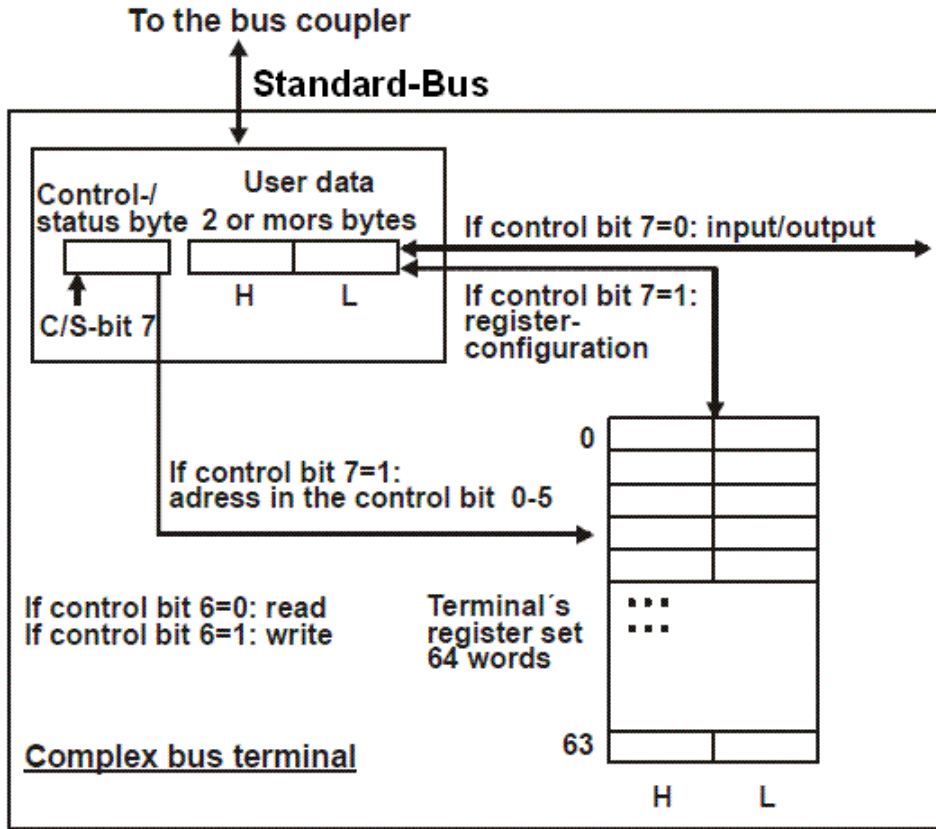

The control or status byte occupies the lowest address of a logical channel. The corresponding register values are located in the following 2 data bytes.

APPENDIX A

This section provides the mechanical drawing of the I/O Terminal.

A.1 I/O 12.0mm Mechanical Drawing

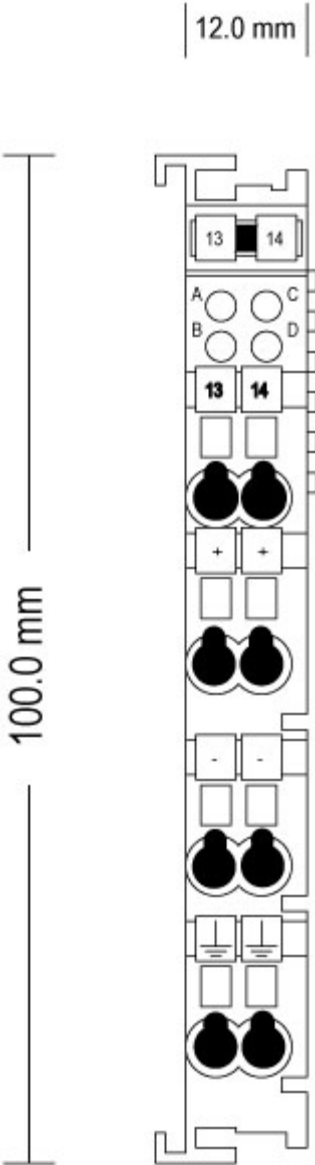

About Kollmorgen

Kollmorgen is a leading provider of motion systems and components for machine builders. Through world-class knowledge in motion, industry-leading quality and deep expertise in linking and integrating standard and custom products, Kollmorgen delivers breakthrough solutions that are unmatched in performance, reliability and ease-of-use, giving machine builders an irrefutable marketplace advantage.

For assistance with your application needs, contact us at: 540-633-3545, contactus@kollmorgen.com or visit www.kollmorgen.com

North America

Kollmorgen

203A West Rock Road
Radford, VA 24141 USA
Phone: 1-540-633-3545
Fax: 1-540-639-4162

Europe

Kollmorgen

Wacholderstraße 40 – 42
40489 Düsseldorf Germany
Phone: + 49 (0) 203-9979-235
Fax: + 49 (0) 203-9979-3314

KOLLMORGEN[®]

Because Motion Matters™