

I/O Terminal Installation Manual



Revision 1.1, June 2011

AKT-CM-000-000 Counter Module, Up/Down



Keep all manuals as a product component during the life span of the product.
Pass all manuals to future users / owners of the product.

KOLLMORGEN[®]

Because Motion Matters™

Record of Document Revisions

Revision	Remarks
1.0	Preliminary edition
1.1	Added dimensions to technical data table and mechanical drawing to Appendix A. For more information, see "Technical Data" page 7 and "Appendix A" page 26.

IMPORTANT NOTICE

Copyright© Kollmorgen™2010-2011. All rights reserved. Kollmorgen holds the copyright to this manual. All rights are reserved and no part of this publication may be reproduced or transmitted in any form or by any means without prior written consent from Kollmorgen.

Disclaimer

The information in this manual was accurate and reliable at the time of its release. However, Kollmorgen. reserves the right to change the specifications of the product described in this manual without notice at any time.

This document contains proprietary and confidential information of Kollmorgen. The contents of the document may not be disclosed to third parties, translated, copied or duplicated in any form, in whole or in part, without the express written permission of Kollmorgen.

Registered Trademarks

Kollmorgen is a registered trademark of Danaher Corp.

Technical changes which improve the performance of the device may be made without prior notice! Printed in the Federal Republic of Germany. All rights reserved. No part of this work may be reproduced in any form (by printing, photocopying, microfilm or any other method) or stored, processed, copied or distributed by electronic means without the written permission of Kollmorgen. All other proprietary names mentioned in this manual are the trademarks of their respective owners.

June 2011

1	Safety Precautions	
1.1	Safety Rules.....	5
1.2	State at Delivery.....	5
1.3	Personnel Qualification	5
1.4	Description of Notes and Warnings	5
2	Overview	
2.1	AKT-CM-000-000 Counter Module, Up/Down	6
2.1.1	Technical Data	7
2.1.2	LED Display	8
2.1.3	Process Data Standard Output Format.....	8
2.1.4	Alternative Output Format.....	8
3	Mounting and Wiring	
3.1	Installation of Bus Terminals on Mounting Rails	9
3.1.1	Assembly.....	9
3.1.2	Disassembly.....	9
3.1.3	Connections Within a Bus Terminal Block.....	9
3.1.4	PE Power Contact.....	10
3.1.5	Wiring	10
3.2	AKT-CM-000-000 Connections.....	11
4	Automatic Configuration	
4.1	Scan Device	12
4.2	Setting I/O Values	12
5	Manual Configuration	
5.1	Mapping in the Bus Coupler.....	14
5.1.1	Standard Format	14
5.1.2	Alternative Format.....	15
5.2	Control and Status Byte	16
5.2.1	Setting the Outputs OUT1, OUT2.....	17
5.3	Register Overview.....	17
5.4	Register Description.....	19
5.4.1	General Register Description.....	19
5.4.2	Process Variables	19
5.4.3	Type Register	20
5.4.4	Manufacturer Parameters	21
5.4.5	User Parameters	21
5.4.6	Extended Application Region.....	21
5.5	Terminal-Specific Register Description.....	22
5.6	Register Communication.....	22
5.6.1	Control Byte in Register Mode	23
5.7	Data Transfer, Function	24

- 5.7.1 Automatic Setting of the Outputs with Defined Counter Readings25
- Appendix A**
- A.1 I/O 12.0 mm Mechanical Drawing.....26

1 SAFETY PRECAUTIONS

This chapter provides safety information for the I/O terminal.

1.1 Safety Rules

The appropriate staff must ensure that the application or use of the products described satisfy all the requirements for safety, including all the relevant laws, regulations, guidelines and standards.

1.2 State at Delivery

All the components are supplied in particular hardware and software configurations appropriate for the application. Modifications to hardware or software configurations other than those described in the documentation are not permitted, and nullify any liability from Kollmorgen.

1.3 Personnel Qualification

This description is only intended for the use of trained specialists in control and automation engineering who are familiar with the applicable national standards.

1.4 Description of Notes and Warnings

The following notes and warnings are used in this manual. They are intended to alert the reader to the associated safety instructions.

Danger — This note is intended to highlight risks for the life or health of personnel.

Warning — This note is intended to highlight risks for equipment, materials or the environment.

Note — Indicates information that contributes to better understanding.

2 OVERVIEW

This section provides an overview of the I/O terminal.

Note: For information about configuring the I/O terminal, see the Kollmorgen Automation Suite™ IDE software and online help system.

2.1 AKT-CM-000-000 Counter Module, Up/Down

The input terminal counts binary pulses and transmits the current value to the higher-level control system. In addition to the 32-bit up/down counter, a 32 bit gated counter or two 16 bit counters are available as operating modes. In the gated counter mode, a low level or high level at the gate input suppresses the terminal's counting function. If two 16 bit counters are active, the U/D input is the clock input for the second counter. Two digital outputs can also be set.

The maximum input frequency is limited to 100 kHz. The minimum pulse width of the input signal is approximately 1 microsecond. The counters react to the rising edge of the input signal.

The terminal's counting function can be suppressed and the outputs can be activated. An internal function can also be activated to enable automatic setting of the outputs at defined counter statuses.

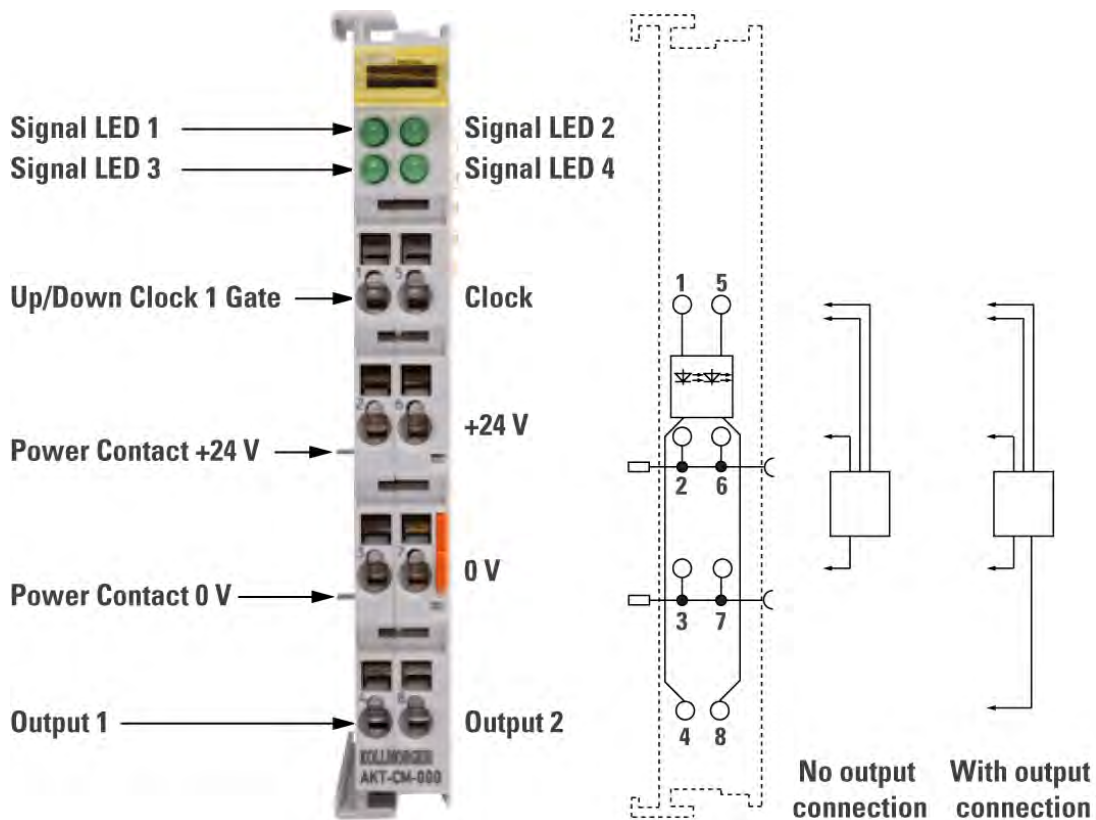

Figure 2.1 Contact Assembly and Connection (Top View)

2.1.1 Technical Data

This section provides the technical details for the 2-channel thermocouple module.

Parameters	AKT-CM-000-000
Number of counters	1 or 2
Rated load voltage	24 V _{DC} (20 V ... 29 V)
'0' signal voltage	-3 V ... 5 V
'1' signal voltage	15 V ... 30 V
Switching frequency	100 kHz (2 kHz by switching U/D)
Input current	Typical 5 mA.
Current consumption from Standard-Bus	Typical 50 mA
Counter depth	32 bit or 2 x 16 bit
Electrical isolation	500 V _{rms} (Standard-Bus / field voltage)
Bit width in the process image	40 I/O: 32 bits data, 8 bits control/status
Configuration	No address settings, configurations via bus coupler or control system
Weight	~50 g
Dimensions (W x H)	~12 mm x 100 mm
Operating temperature	0°C ... +55°C
Storage temperature	-25°C ... +85°C
Relative humidity	95%, no condensation
Vibration / Shock resistance	Conforms to EN 60068-2-6 / EN 60068-2-27, EN 60068-2-29
EMC resistance burst / ESD	Conforms to EN 61000-6-2 / EN 61000-6-4
Installation position	Any
Type of protection	IP20

2.1.2 LED Display

The LEDs indicate the states of the U/D and CLOCK inputs as well as the states of the outputs OUT1 and OUT2.

2.1.3 Process Data Standard Output Format

When using the standard output format, 5 bytes (4 bytes of user information data and 1 control/status byte) are mapped. The process data differs depending on the set function:

- Gated counter:
32 bit unsigned integer
- Up/down counter:
32 bit signed integer
- Two active counters:
2 x 16 bit unsigned integer

Mapping of the terminal in the standard format is described in further detail in the appendix.

2.1.4 Alternative Output Format

If the alternative output format is chosen, pay attention to the fact that the output length (4 bytes or 6 bytes instead of 5 bytes) and mapping of the terminal are changed.

- Up/down counter:
24 bit signed integer
- Gated counter:
24 bit signed integer
- Two active counters:
1 x 8 bit counter0 and 1 x 16-bit counter1

3 MOUNTING AND WIRING

This section provides mounting and wiring information for the operator terminal.

Note: For information about configuring the I/O terminal, see the Kollmorgen Automation Suite™ IDE software and online help system.

3.1 Installation of Bus Terminals on Mounting Rails

DANGER!! Bring the bus terminal system into a safe, powered down state before starting installation, disassembly or wiring of the Bus Terminals!

3.1.1 Assembly

The Bus Coupler and Bus Terminals are attached to commercially available 35 mm mounting rails (DIN rails according to EN 50022) by applying slight pressure:

1. First attach the Fieldbus Coupler to the mounting rail.
2. The Bus Terminals are now attached on the right-hand side of the Fieldbus Coupler. Join the components with tongue and groove and push the terminals against the mounting rail, until the lock clicks onto the mounting rail.

If the Terminals are clipped onto the mounting rail first and then pushed together without tongue and groove, the connection will not be operational! When correctly assembled, no significant gap should be visible between the housings.

During the installation of the Bus Terminals, the locking mechanism of the terminals must not come into conflict with the fixing bolts of the mounting rail.

3.1.2 Disassembly

Each terminal is secured by a lock on the mounting rail, which must be released for disassembly:

1. Carefully pull the orange-colored lug approximately 1 cm out of the disassembled terminal, until it protrudes loosely. The lock with the mounting rail is now released for this terminal, and the terminal can be pulled from the mounting rail without excessive force.
2. Grasp the released terminal with thumb and index finger simultaneous at the upper and lower grooved housing surfaces and pull the terminal away from the mounting rail.

3.1.3 Connections Within a Bus Terminal Block

The electric connections between the Bus Coupler and the Bus Terminals are automatically realized by joining the components:

- The six spring contacts of the Standard Bus/Performance Bus deal with the transfer of the data and the supply of the Bus Terminal electronics.
- The power contacts deal with the supply for the field electronics and thus represent a supply rail within the bus terminal block. The power contacts are supplied via terminals on the Bus Coupler.

Note: During the design of a bus terminal block, the pin assignment of the individual Bus Terminals must be taken account of, since some types (e.g. analog Bus Terminals or digital 4-channel Bus Terminals) do not or not fully loop through the power contacts. Power Feed Terminals interrupt the power contacts and thus represent the start of a new supply rail.

3.1.4 PE Power Contact

The power contact labeled PE can be used as a protective earth. For safety reasons this contact mates first when plugging together, and can ground short-circuit currents of up to 125 A.

WARNING!! Note that, for reasons of electromagnetic compatibility, the PE contacts are capacitatively coupled to the mounting rail. This may lead to incorrect results during insulation testing or to damage on the terminal (e.g. disruptive discharge to the PE line during insulation testing of a consumer with a nominal voltage of 230 V).

For insulation testing, disconnect the PE supply line at the Bus Coupler or the Power Feed Terminal! In order to decouple further feed points for testing, these Power Feed Terminals can be released and pulled at least 10 mm from the group of terminals.

Note: The PE power contact must not be used for other potentials!

3.1.5 Wiring

Up to eight connections enable the connection of solid or finely stranded cables to the Bus Terminals. The terminals are implemented in spring force technology. Connect the cables as follows:

1. Open a spring-loaded terminal by slightly pushing with a screwdriver or a rod into the square opening above the terminal.
2. The wire can now be inserted into the round terminal opening without any force.
3. The terminal closes automatically when the pressure is released, holding the wire securely and permanently.

Note: Analog sensors and actors should always be connected with shielded, twisted paired wires.

3.2 AKT-CM-000-000 Connections

The section describes the connections for the Counter module.

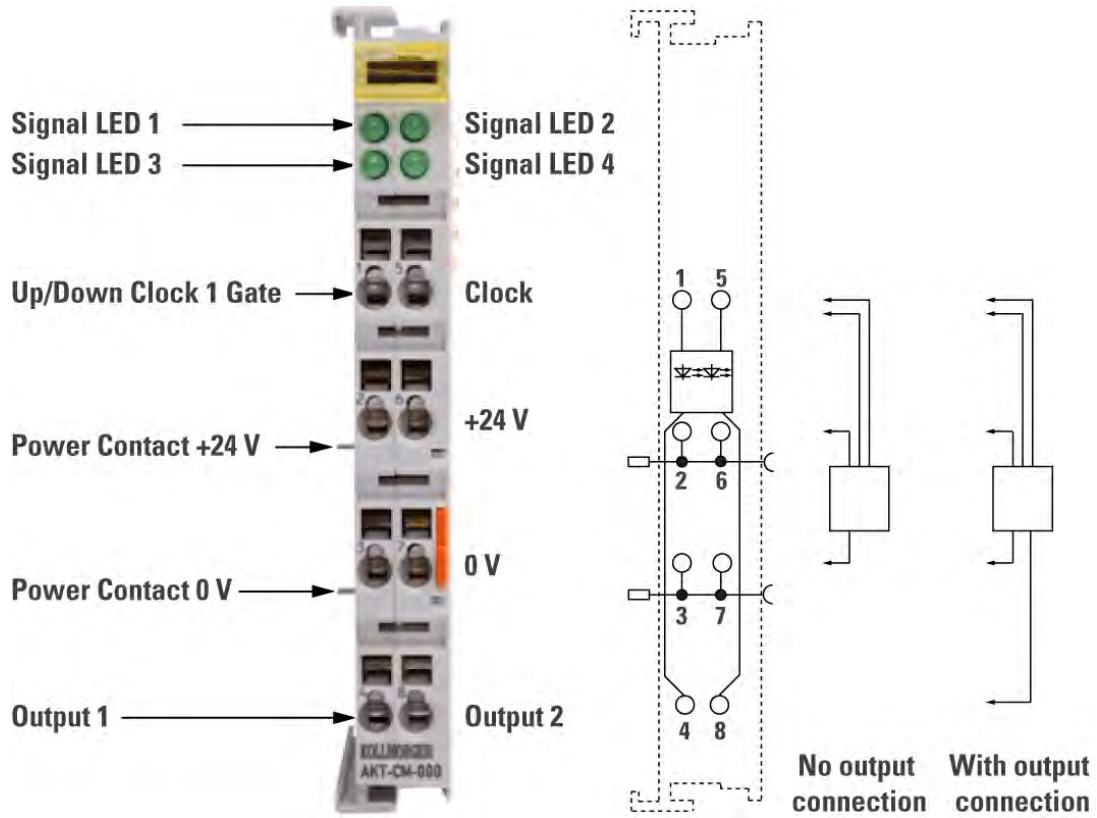

Figure 3.1 Terminal Connections (Counter Module)

4 AUTOMATIC CONFIGURATION

This chapter describes the basics of automatic configuration within the KAS Integrated Development Environment (IDE).

4.1 Scan Device

For ease-of-use the KAS IDE Scan Device feature provides automatic integration of I/O devices. This allows you to automatically locate and add I/O terminals to the application project:

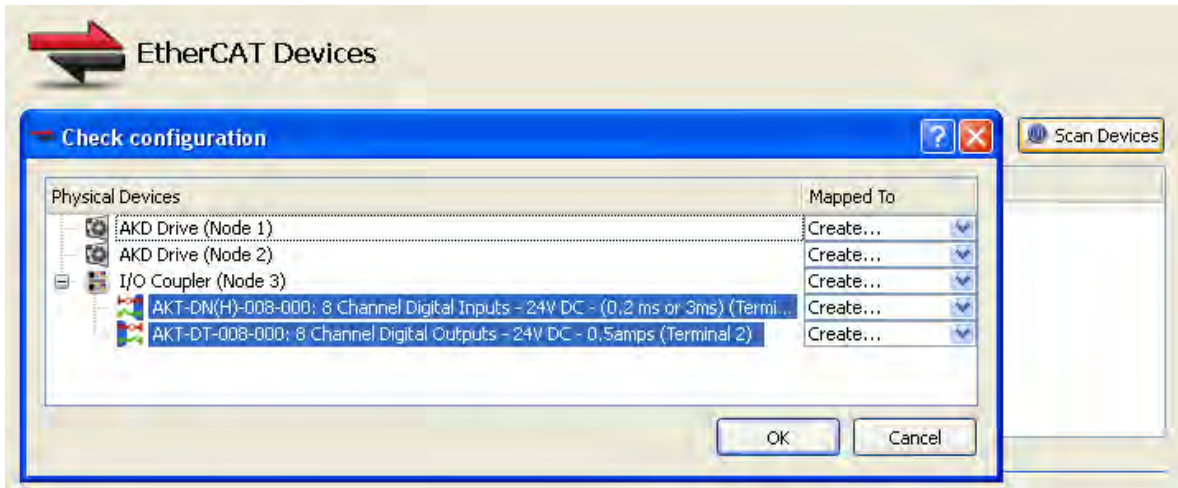

4.2 Setting I/O Values

After the I/O slice is mapped it can be selected in the application project and the offset and gain values can be set. Additionally, the IDE allows you to map the I/O points to variables in your application:

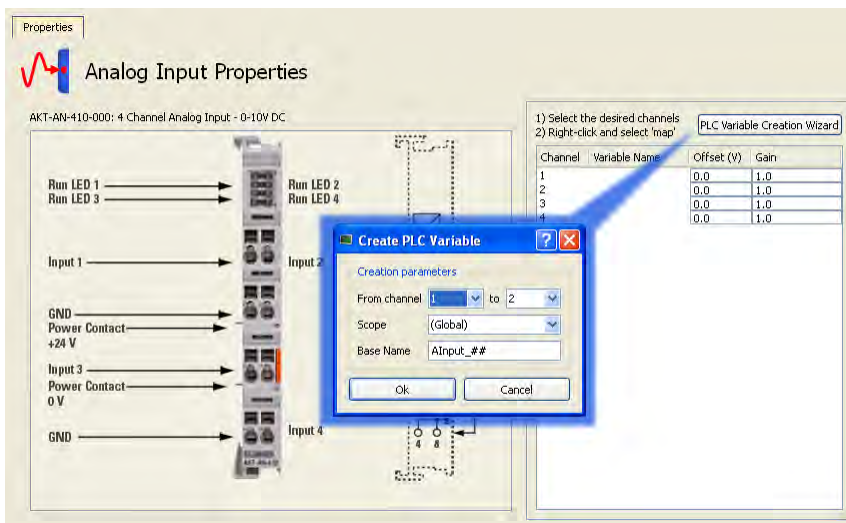

For more detailed information on these procedures refer to the section “EtherCAT Scan Device” in the KAS IDE online help.

5 MANUAL CONFIGURATION

Kollmorgen strongly recommends automatic configuration using the KAS IDE over manual configuration. For automatic configuration refer to chapter 5. Manual configuration is for advanced procedures only. The following sections provide the necessary configuration information to manually map the I/O device.

Contrary to the analog and output terminals, in the case of the AKT-CM-000-000 the control and status byte is always mapped, regardless of the field bus system used.

5.1 Mapping in the Bus Coupler

This section covers mapping in the bus coupler.

5.1.1 Standard Format

In the Standard format the AKT-CM-000-000 is mapped in the bus coupler with 5 bytes input and 5 bytes output data.

Default Mapping for CAN

Conditions	Word offset	High byte	Low byte
Complete evaluation: don't care	0	D0	CB/SB
Motorola format: no	1	D2	D1
Word alignment: no	2	Res.	D3

Default mapping for Profibus Coupler

Conditions	Word offset	High byte	Low byte
Complete evaluation: don't care	0	D3	CB/SB
Motorola format: yes	1	D1	D2
Word alignment: no	2	Res.	D0

Default mapping for EtherCAT

Conditions	Word offset	High byte	Low byte
Complete evaluation: don't care	0	Res	CB/SB
Motorola format: no	1	D1	D0
Word alignment: yes	2	D3	D2

Conditions	Word offset	High byte	Low byte
Complete evaluation: don't care	0	Res	CB/SB

Conditions	Word offset	High byte	Low byte
Motorola format: yes Word alignment: yes	1	D2	D3
	2	D0	D1

5.1.2 Alternative Format

In the Alternative format the AKT-CM-000-000 is mapped in the bus coupler with 4/6 bytes input and 4/6 bytes output data.

Conditions	Word offset	High byte	Low byte
Complete evaluation: no Motorola format: no Word alignment: no	0	D0	Cnt-CB/SB
	1	D2	D1

Conditions	Word offset	High byte	Low byte
Complete evaluation: no Motorola format: yes Word alignment: no	0	Cnt-CB/SB	D0
	1	D1	D2

Conditions	Word offset	High byte	Low byte
Complete evaluation: yes Motorola format: no Word alignment: no	0	Cnt-CB/SB	CB/SB
	1	Res.	D0
	2	D2	D1

Conditions	Word offset	High byte	Low byte
Complete evaluation: yes Motorola format: yes Word alignment: no	0	D0	CB/SB
	1	Res.	Cnt-CB/SB
	2	D1	D2

Conditions	Word offset	High byte	Low byte
Complete evaluation: yes Motorola format: no	0	Res.	CB/SB
	1	Cnt-CB/SB	D0

Conditions	Word offset	High byte	Low byte
Word alignment: yes	2	Res.	Res.
	3	D1	D2

Key: Complete evaluation: The terminal is mapped with control and status byte.

Motorola format: Motorola or Intel format can be set.

Word alignment: The terminal is at word limit in the Bus Coupler.

Ch n SB: status byte for channel n (appears in the input process image).

Ch n CB: control byte for channel n (appears in the output process image).

Ch n D0: channel n, data byte 0 (byte with the lowest value)

Ch n D1: channel n, data byte 1 (byte with the highest value)

"-": This byte is not used or occupied by the terminal.

res.: reserved: This byte occupies process data memory, although it is not used.

5.2 Control and Status Byte

The control byte is transmitted from the controller to the terminal. It can be used

- in register mode (REG = 1bin) or
- during process data exchange (REG = 0bin).

Control byte during process data exchange

The control byte triggers various actions in the counter terminal KL1501 during process data exchange:

MSB						
Reg = 0	CNT_SET	CNT_INH	SET_OUT2	SET_OUT1	EN_OUT2	ENOUT_1

Bit	Function
CNT_SET	The counter is set to the value that is specified via the process data. Setting of the counter can be edge or level-controlled (see R32.3).
CNT_INH	The counter is stopped as long as this bit is active. In doing so, the old counter status is retained. If two counters are active, the second counter can be set with this bit.
SET_OUT2	Sets the second output
SET_OUT1	Sets the first output
EN_OUT2	This bit enables the internal function activated by R32.
EN_OUT1	This bit enables the internal function activated by R32.

5.2.1 Setting the Outputs OUT1, OUT2

The functions for setting the outputs can be armed with the control bits EN_OUT1, EN_OUT2. The control bits SET_OUT1 and SET_OUT2 are ignored when EN_OUT1, EN_OUT2 is set.

Status byte during process data exchange

The status byte is transferred from the terminal to the control system. The status byte contains various status bits of the counter terminal KL1501:

MSB							
Reg = 0	0	SET_ACC	INH_ACC	ST_OUT2	ST_OUT1	ST_V/R	ST_CLK

Bit	Function
SET_ACC	The data for setting the counter has been accepted from the terminal.
INH_ACC	The counter is stopped for as long as this bit is set.
ST_OUT2	The status of output OUT2 is reflected in this bit.
ST_OUT1	The status of output OUT1 is reflected in this bit.
ST_V/R	The status of the V/R input is reflected in this bit.
ST_CLK	The status of the CLOCK input is reflected in this bit.

5.3 Register Overview

Register No.	Description	Default	R/W	Storage Medium
R0	Not used	0x0000	R	
...
R5	Not used	0x0000	R	
R6	Diagnostic register – not used	0x0000	R	
R7	Command register – not used	0x0000	R	
R8	Terminal type	1501	R	ROM
R9	Software version number	0x????	R	ROM
R10	Multiplex-shift register	0x0130	R	ROM
R11	Signal channels	0x0128	R	ROM
R12	Minimum data length	0x2828	R	ROM

Register No.	Description	Default	R/W	Storage Medium
R13	Data structure	0x0000	R	ROM
R14	Not used	0x0000	R	
R15	Alignment-register	Variable	R/W	RAM
R16	Hardware version number	0x????	R/W	SEEROM
R17	Not used	0x0000	R/W	SEEROM
...
R30	Not used	0x0000	R/W	SEEROM
R31	Code word register	Variable	R/W	RAM
R32	Feature register	0x0100	R/W	SEEROM
R33	Not used	0x0000	R/W	SEEROM
...
R63	Not used	0x0000	R/W	SEEROM

5.4 Register Description

The complex terminals can be adjusted to different operating modes or functionalities. The General Description of Register describes the contents of the registers, which are identical for all complex terminals.

The terminal-specific registers are explained in the section following to it.

The access to the internal registers of the terminal is described in the section Register Communication.

5.4.1 General Register Description

Complex terminals that possess a processor are capable of bi-directionally exchanging data with the higher-level control system. Below, these terminals are referred to as intelligent bus terminals. They include the analog inputs, the analog outputs, serial interface terminals (RS485, RS232, TTY etc.), counter terminals, encoder interfaces, SSI interfaces, PWM terminals and all other parameterizable terminals.

Internally, all intelligent terminals possess a data structure that is identical in terms of its essential characteristics. This data area is organized in words and embraces 64 registers. The essential data and parameters of the terminal can be read and adjusted by way of the structure. Function calls with corresponding parameters are also possible. Each logical channel of an intelligent terminal has such a structure (therefore, 4-channel analog terminals have 4 register sets).

The structure is broken down into the following areas:

Register	Application
0 to 7	Process variables
8 to 15	Type register
16 to 30	Manufacturer parameters
31 to 47	User parameters
48 to 63	Extended user area

5.4.2 Process Variables

R0 to R7: Registers in the internal RAM of the terminal – The process variables can be used in addition to the actual process image. Their function is specific to the terminal.

R0 to R5: Terminal-specific registers – The function of these registers depends on the respective terminal type (see terminal-specific register description).

R6: Diagnostic register – The diagnostic register can contain additional diagnostic information. Parity errors, for instance, that occur in serial interface terminals during data transmission are indicated here.

R7: Command register

High-Byte_Write = function parameter

Low-Byte_Write = function number

High-Byte_Read = function result

Low-Byte_Read = function number

5.4.3 Type Register

R8 to R15: Registers in the internal ROM of the terminal – The type and system parameters are hard programmed by the manufacturer, and the user can read them but cannot change them.

R8: Terminal type – The terminal type in register R8 is needed to identify the terminal.

R9: Software version (X.y) – The software version can be read as a string of ASCII characters.

R10: Data length – R10 contains the number of multiplexed shift registers and their length in bits. The Bus Coupler sees this structure.

R11: Signal channels – Related to R10, this contains the number of channels that are logically present. Thus for example a shift register that is physically present can perfectly well consist of several signal channels.

R12: Minimum data length – The particular byte contains the minimum data length for a channel that is to be transferred. If the MSB is set, the control and status byte is not necessarily required for the terminal function and is not transferred to the control, if the Bus Coupler is configured accordingly.

R13: Data type register

Data Type Register	Description
0x00	Terminal with no valid data type
0x01	Byte array
0x02	Structure 1 byte n bytes
0x03	Word array
0x04	Structure 1 byte n words
0x05	Double word array
0x06	Structure 1 byte n double words
0x07	Structure 1 byte 1 double word
0x08	Structure 1 byte 1 double word
0x11	Byte array with variable logical channel length
0x12	Structure 1 byte n bytes with variable logical channel length (e.g. 60xx)
0x13	Word array with variable logical channel length

Data Type Register	Description
0x14	Structure 1 byte n words with variable logical channel length
0x15	Double word array with variable logical channel length
0x16	Structure 1 byte n double words with variable logical channel length

R14: Reserved

R15: Alignment bits (RAM) – The alignment bits are used to place the analog terminal in the Bus Coupler on a byte boundary.

5.4.4 Manufacturer Parameters

R16 to R30: Manufacturer parameter area (SEEPROM) – The manufacturer parameters are specific for each type of terminal. They are programmed by the manufacturer, but can also be modified by the controller. The manufacturer parameters are stored in a serial EEPROM in the terminal, and are retained in the event of voltage drop-out. These registers can only be altered after a code-word has been set in R31.

5.4.5 User Parameters

R31 to R47: User parameter area (SEEPROM) – The application parameters are specific for each type of terminal. They can be modified by the programmer. The application parameters are stored in a serial EEPROM in the terminal, and are retained in the event of voltage drop-out. The user area is write-protected by a code-word.

R31: Code-word register in RAM – The code-word **0x1235** must be entered here so that parameters in the user area can be modified. If any other value is entered into this register, the write-protection is active. When write protection is not active, the code word is returned when the register is read. If the write protection is active, the register contains a zero value.

R32: Feature register – This register specifies the terminal's operating modes. Thus, for instance, a user-specific scaling can be activated for the analog I/Os.

R33 to R47 Terminal-specific Registers – The function of these registers depends on the respective terminal type (see terminal-specific register description).

5.4.6 Extended Application Region

R47 to R63 – Extended registers with additional functions.

5.5 Terminal-Specific Register Description

R32: Feature register

[0x0100]

The feature register specifies the operating modes of the terminal.

Feature bit no.		Description of the mode
Bit 0	-	No function
Bit 1	0/1	Output format 0: Standard output [0] 1: Alternative output
Bit 2	1	If two counters are active, the CNT_INH bit becomes CNT_SET for the second counter [0].
Bit 3	1	The counter(s) is/are set with a positive edge of the CNT_SET bit in the control byte [0]
Bit 4	1	The internal function for setting output OUT1 is active [0].
Bit 5	1	The internal function for resetting output OUT1 is active [0].
Bit 6	1	The internal function for setting output OUT2 is active [0].
Bit 7	1	The internal function for resetting output OUT2 is active [0].
Bit 10, 9, 8	001	32-bit up/down counter [001]. 24-bit if alternative output format is active.
	010	Standard output: 2 *16-bit up counter Alternative output: counter0 is 8 bits and counter1 is 16 bits wide The counting frequency is limited to approximately 5 kHz. [Pulse width > 100 microseconds]
	100	32-bit gated counter 24-bit if alternative output format is active gate input low: counter is disabled
	101	32-bit gated counter 24-bit if alternative output is active gate input high: counter is disabled
Bit 11	0/1	Counting direction 0: Up [0] 1: Down
Bit 12	1	Terminal bus access is polled if the bit is set [0]
Bit 15, 14, 13	-	No function [0], don't change

5.6 Register Communication

Register Access Via Process Data Exchange | Bit 7=1bin: Register Mode

If bit 7 of the control byte is set, then the first two bytes of the user data are not used for exchanging process data, but are written into or read from the terminal's register set.

Bit 6=0_{bin}: read | Bit 6=1_{bin}: write

Bit 6 of the control byte specifies whether a register should be read or written. If bit 6 is not set, then a register is read out without modifying it. The value can then be taken from the input process image.

If bit 6 is set, then the user data is written into a register. As soon as the status byte has supplied an acknowledgement in the input process image, the procedure is completed (see example).

Bit 0 to 5: Address

The address of the register that is to be addressed is entered into bits 0 to 5 of the control byte.

5.6.1 Control Byte in Register Mode

MSB							
Reg = 1	W/R	A5	A4	A3	A2	A1	A0

REG = 0_{bin}: Process data exchange

REG = 1_{bin}: Access to register structure

W/R = 0_{bin}: Read register

W/R = 1_{bin}: Write register

A5...A0 = register address

Address bits A5 to A0 can be used to address a total of 64 registers.

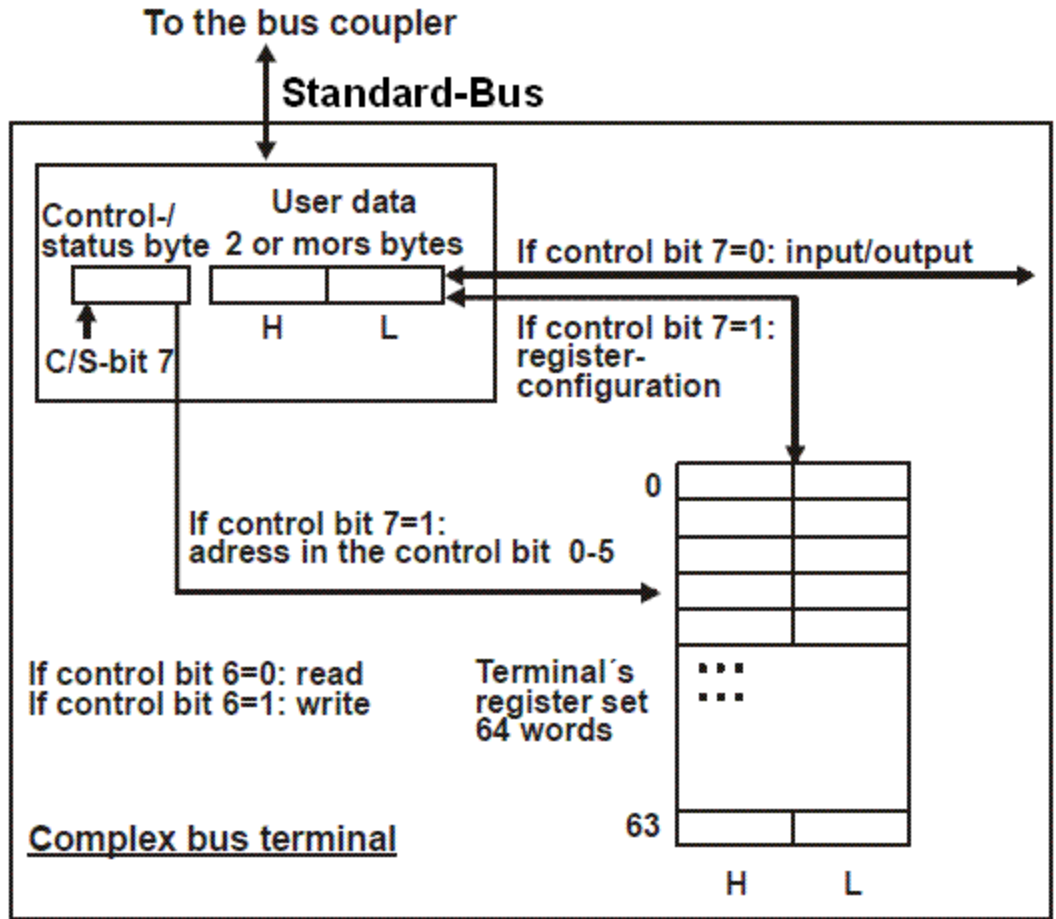

The control or status byte occupies the lowest address of a logical channel. The corresponding register values are located in the following 2 data bytes.

5.7 Data Transfer, Function

This section covers automatic setting of the outputs.

5.7.1 Automatic Setting of the Outputs with Defined Counter Readings**V/R counter or gated counter**

An internal function for setting the outputs can be activated via the feature register R32:

If the counter reaches the counter status 0x80000000 the output OUT1 is set (feature bit 5) or is reset (feature bit 6).

If the counter overflows, the output is withdrawn accordingly.

In parallel, output OUT2 is set with bit 15 (0x8000).

Two counters active

If the corresponding counter reaches the counter status 0x8000 the output (OUT2, OUT1) is set (feature bit 4,6) or is reset (feature bit 5,7).

If the counter overflows, the output is withdrawn accordingly.

Example

Feature register = 0x02AC, i.e. two counters are active, the counter is set via the positive edge of the CNT_SET bits and the control bit CNT_INH is responsible for setting the second counter.

A glass is to be filled with 200 ml of beer. In doing so, one pulse corresponds to 0.01 ml, i.e. one glass corresponds to 20000 pulses (0x31E0 = 0x8000-20000).

First counter	Control Byte	Status Byte	Output data	Output OUT1	Function
0x0000	0x00	0x00	0x0000	Low	Power on reset
0x0000	0x22	0x00	0x31Ex	Low	Counter is set, internal function activated
0x31Ex	0x02	0x28	Don't care	High	Beer is running
...					
0x8000	0x02	0x00	Don't care	Low	The first glass is full
...					
0x8000	0x22	0x00	0x31E0	Low	Counter is set, internal function activated
0x31Ex	0x02	0x28	Don't care	High	Beer is running
...					
0x8000	0x02	0x00	Don't care	Low	The second glass is full
...					

APPENDIX A

This section provides the mechanical drawing of the I/O Terminal.

A.1 I/O 12.0 mm Mechanical Drawing

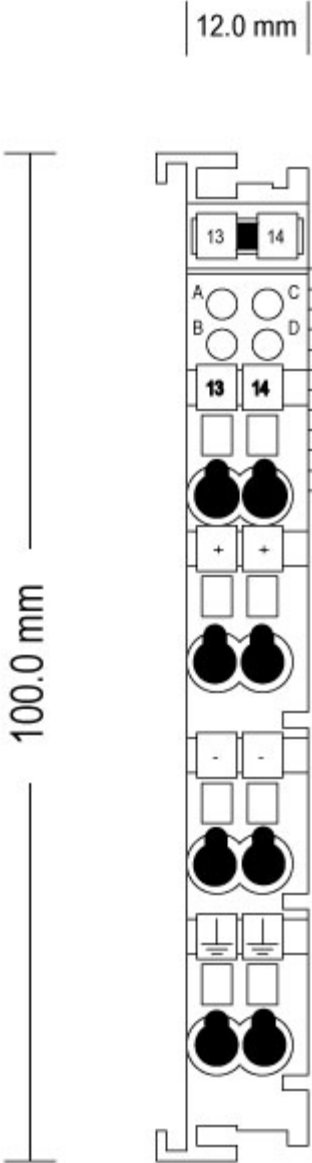

About Kollmorgen

Kollmorgen is a leading provider of motion systems and components for machine builders. Through world-class knowledge in motion, industry-leading quality and deep expertise in linking and integrating standard and custom products, Kollmorgen delivers breakthrough solutions that are unmatched in performance, reliability and ease-of-use, giving machine builders an irrefutable marketplace advantage.

For assistance with your application needs, contact us at: 540-633-3545, contactus@kollmorgen.com or visit www.kollmorgen.com

North America

Kollmorgen

203A West Rock Road
Radford, VA 24141 USA
Phone: 1-540-633-3545
Fax: 1-540-639-4162

Europe

Kollmorgen

Wacholderstraße 40 – 42
40489 Düsseldorf Germany
Phone: + 49 (0) 203-9979-235
Fax: + 49 (0) 203-9979-3314

KOLLMORGEN[®]

Because Motion Matters™