

Stepper Module, 24 V DC, 1.5 A

The Bus Terminal is intended for the direct connection of different small stepper motors. The slimline PWM output stages for two motor coils are located in the Bus Terminal together with two inputs for limit switches. The terminal can be adjusted to the motor and the application by changing just a few parameters. 64-fold micro-stepping ensures particularly quiet and precise motor operation. In many applications, integrated zero-speed monitoring makes an encoder system or limit switch unnecessary.

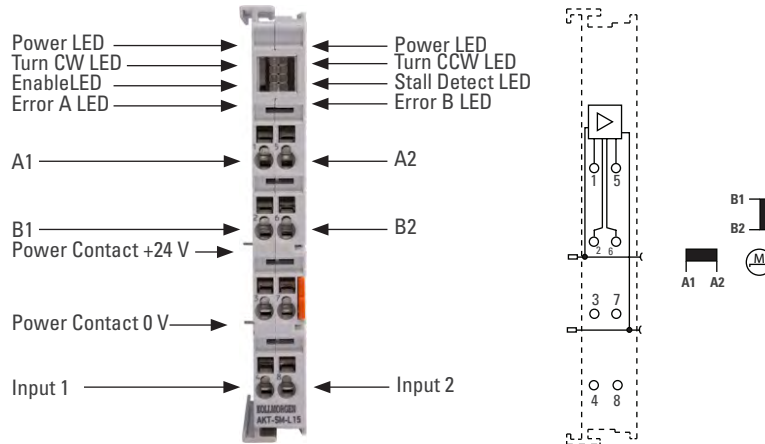

Electrical and Mechanical Specification	AKT-SM-L15-000
Number of outputs	1 Stepper Motor, 2 phases
Number of inputs	2
Output current	2 x 1 A, 2 x 1.5 A peak current, overload- and short-circuit-proof
Maximum step frequency	125,000 steps/s
Step pattern	Full step, half step, up to 64-fold micro stepping
Current controller frequency	Approx. 25 kHz
Diagnostics LED	Error phase A and B, loss of step/stagnation, power, enable
Resolution	Approx. 5,000 positions in typ. applications (per revolution)
Power supply	8...24 V DC (for output stage over power contacts)
Electrical isolation	500 V _{rms} (standard-bus / signal voltage)
Current consumption standard-bus	Typ. 60 mA
Bit width in the process image	Input: n x 2 x 16 bit data, 2 x 16 bit control/status
Weight	50 g
Operating/storage temperature	0 ... +55 °C / -25 ... +85 °C
Relative humidity	95 %, no condensation
Vibration/shock resistance	Conforms to EN 60068-2-6 / EN 60068-2-27/ 29
EMC immunity/emission	Conforms to EN 61000-6-2 / EN 61000-6-4
Protect. class/installation pos.	IP 20 / variable
Pluggable wiring	For all Bus Terminals

203 A West Rock Road • Radford, VA 24141 USA • Phone: 1-540-633-3545

KOLLMORGEN | www.kollmorgen.com