

AKI-CDC-MOD-12T Quick Start Guide

1 General

1.1 About This Manual

All Advanced Kollmorgen Interfaces are developed to satisfy the demands of human-machine communication. Built-in functions such as displaying and controlling text, dynamic indication, time channels, alarm and recipe handling are included.

The Advanced Kollmorgen Interfaces works primarily in an object-oriented way, making it easy to understand and use. Configuration is carried out on a PC using the Kollmorgen Visualization Builder configuration tool. The project can then be transferred and stored in the operator panel itself.

Various types of automation equipment such as PLCs, servos or drives can be connected to the Advanced Kollmorgen Interfaces. In this manual, the term "the controller" refers to the connected equipment.

This manual explains how to install the operator panel. Please refer to the Kollmorgen Visualization Builder **Programming and Installation** manual for further information.

2 Safety Precautions

Both the installer and the owner and/or operator of the operator panel must read and understand this installation manual.

2.1 General

- Read the safety precautions carefully.
- Check the delivery for transportation damage. If damage is found, notify the supplier as soon as possible.
- Do not use the operator panel in an environment with high explosive hazards.
- The supplier is not responsible for modified, altered or reconstructed equipment.
- Use only parts and accessories manufactured according to specifications of the supplier.
- Read the installation and operating instructions carefully before installing, using or repairing the operator panel.
- Never allow fluids, metal filings or wiring debris to enter any openings in the operator panel. This may cause fire or electrical shock.
- Only qualified personnel may operate the operator panel.
- Storing the operator panel where the temperature is lower/higher than recommended in this manual can cause the LCD display liquid to congeal/become isotopic.
- The LCD display liquid contains a powerful irritant. In case of skin contact, wash immediately with plenty of water. In case of eye contact, hold the eye open, flush with plenty of water and get medical attention.
- The figures in this manual serves an illustrative purpose. Because of the many variables associated with any particular installation, the supplier cannot assume responsibility for actual use based on the figures.
- The supplier neither guarantees that the operator panel is suitable for your particular application, nor assumes responsibility for your product design, installation or operation.
- It is recommended to turn on and shut down the operator panel at least once before installing any components/cards or before connecting the operator panel to external devices, like for example serial devices.

2.2 During Installation

- The operator panel is designed for stationary installation on a plane surface, where the following conditions are fulfilled:
 - no high explosive risks
 - no strong magnetic fields
 - no direct sunlight
 - no large, sudden temperature changes

- Install the product according to the accompanying installation instructions.
- Ground the product according to the accompanying installation instructions.
- Only qualified personnel may install the operator panel.
- Separate the high voltage, signal and supply cables.
- Make sure that the voltage and polarity of the power source is correct before connecting the product to the power outlet.
- Peripheral equipment must be appropriate for the application and location.

2.3 During Use

- Keep the operator panel clean.
- Emergency stop and other safety functions may not be controlled from the operator panel.
- Do not use too much force or sharp objects when touching the keys, touchscreen etc.

2.4 Service and Maintenance

- Only qualified personnel should carry out repairs.
- The agreed warranty applies.
- Before carrying out any cleaning or maintenance operations, disconnect the equipment from the electrical supply.
- Clean the display and surrounding front cover with a soft cloth and mild detergent.
- Replacing the battery incorrectly may result in explosion. Only use batteries recommended by the supplier. During the warranty period, the battery needs to be replaced by an authorized Kollmorgen service center.
- The unit can be reset by using the reset switch located behind the fan.

2.5 Dismantling and Scrapping

- The operator panel or parts thereof shall be recycled according to local regulations.
- The following components contain substances that might be hazardous to health and the environment: lithium battery, electrolytic capacitor and display.

2.6 Appearance of Air in Touch Screen

- The layer structure of the touch screen contains air and in rare cases appearance of bubbles can arise. This is purely cosmetic and does not affect any functionality of the panel. The appearance can occur under certain environmental conditions such as temperature, humidity, and atmospheric pressure.

3 Installation

3.1 Space Requirements

- Maximum installation plate thickness: 8 mm
- Space requirements in millimeters when installing the operator panel:

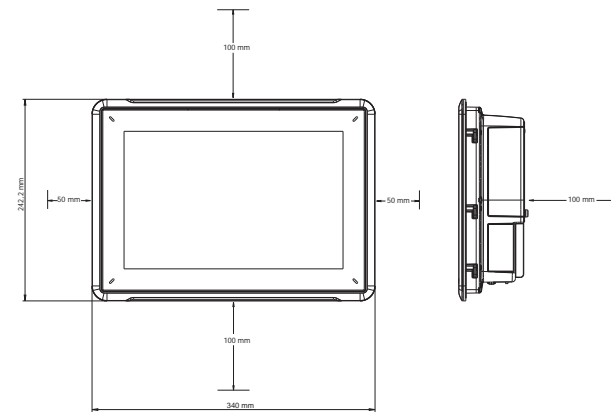

Note:
The dimensions on the drawing are not proportional.

Caution:
The openings on the enclosure are for air convection. Do not cover these openings.

3.2 Installation Process

The following is needed:

- A Torx TX7 screwdriver

- Unpack and check the delivery. If damage is found, notify the supplier.

Note:
Place the operator panel on a stable surface during installation. Dropping the panel or letting it fall may cause damage.

- Use the cut out dimensions that are included on the outline drawing, found in section [Operator Panel Drawings](#) and in the [Technical Data](#) table, to cut a correct opening in the cabinet.
- Secure the operator panel in position by screwing the M4 Torx screw, allowing the built-in bracket to tighten against the panel:

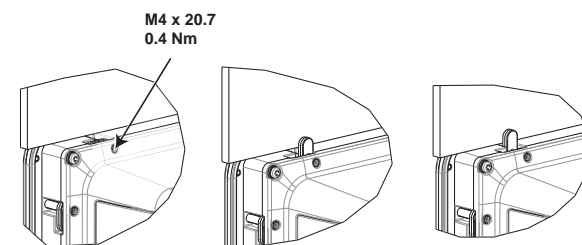

- Connect the cables in the specified order, according to the drawing and steps below.

Caution:

- Ensure that the operator panel and the controller system have the same electrical grounding (reference voltage level), otherwise errors in communication may occur.
- The operator panel must be brought to ambient temperature before it is started up. If condensation forms, ensure that the operator panel is dry before connecting it to the power outlet.
- Ensure that the voltage and polarity of the power source is correct.
- Use only shielded communication cables.
- Separate high voltage cables from signal and supply cables.

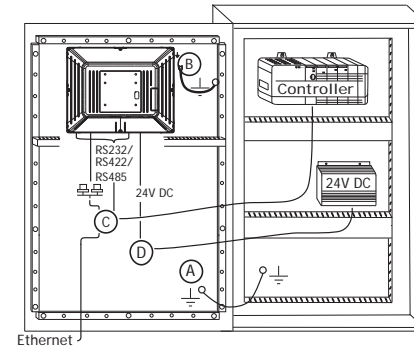

- Connect cable A.
- Connect cable B, using an M5 screw and a grounding conductor (as short as possible) with a cross-section of minimum 2.5 mm².
- Connect cable C.
- Connect cable D. The recommended cross-section of the cable is 2.5 mm².

- Carefully remove the laminated film over the operator panel display, to avoid static electricity that could damage the panel.

3.2.1 Connections to the Controller

For information about the cables to be used when connecting the operator panel to the controller, please refer to the help file for the driver in question.

3.2.2 Other Connections and Peripherals

Cables, peripheral equipment and accessories must be suitable for the application and its environment. For further details or recommendations, please refer to the supplier.

4 Technical Data

Parameter	AKI-CDC-MOD-12T
Front panel, W × H × D	340 × 242 × 79 mm
Cut out dimensions, W × H	324 × 226 mm
Mounting depth	72 mm (172 mm including clearance)
Standalone mounting	VESA 100 × 100 Note: Maximum screw length for VESA mounting is 5.5 mm. Usage of longer screws may lead to damage.
Front panel seal	IP 65
Rear panel seal	IP 20
Touch screen material	Polyester on glass, resistive. Overlay: Autotex F157 or F207 ⁽¹⁾ .
Touch screen operations	1 million finger touch operations
Reverse side material	Powder-coated aluminum
Frame material	Powder-coated aluminum
Weight	4.2 kg
Serial port for COM1 RS232 and COM2 RS422/RS485	9-pin D-sub contact with RS232 RTS/CTS, chassis-mounted female with standard locking screws 4-40 UNC Note: RS422 Interface is not available yet.
Serial port for COM3 RS232 and COM4 RS422/RS485	9-pin D-sub contact with RS232 RTS/CTS, chassis-mounted female with standard locking screws 4-40 UNC Note: RS422 Interface is not available yet.
Ethernet	2 × 10/100/1000 Base-T (shielded RJ 45)
USB	4 × USB Host 2.0, max output current 500 mA
Processor	Intel® Celeron® B810E (2 × 1.6 GHz), 2 MB L2 Cache, Intel® QM67 Chipset Optional: Intel® Core™ i3 2310E (2 × 2.1 GHz) (Hyperthreading), 3 MB L2 Cache, QM67 Chipset Optional: Intel® Core™ i7 2715QE (4 × 2.1 GHz) (Turbo 2.0, Hyperthreading), 6 MB L2 Cache, QM67 Chipset *for exact configuration please see price list
External storage media	via USB
Memory RAM	2 GB* / 4 GB* DDR-3 SO-DIMM 1333 MHz *depending on Processor Module
LED	1 × multi-color
Real time clock	Yes (on chip)
Battery	Lithium battery type BR 2032 (or CR 2032), exchangeable
Power consumption at rated voltage	107 W
Fuse	10 A
Power supply	DC input range: 18-32 V DC (140W) ATX standard CE: The power supply must conform with the requirements according to IEC 60950 and IEC 61558-2-4. UL and cUL: The power supply must conform with the requirements for class II power supplies.
Display	TFT-LCD with LED backlight. 1280 × 800 pixels, 16.7 million colors
VGA	1 × VGA: resolution max. 2048 × 1536@75Hz
DVI	1 × DVI-D single Link: Resolution max. 1600 × 1200 or 1920 × 1200 (with reduced blanking)
Active area of display, W × H	261.12 × 163.2 mm
Operating temperature	0 °C - +50 °C
Storage temperature	-20 °C - +70 °C
Relative humidity	5% - 85% non-condensed

5 Chemical Resistance

5.1 Metal Casing

The frame and casing material is powder-coated aluminum. This powder paint withstands exposure to the following chemicals without visible change:

Acetic acid 10%	Phosphoric acid 4%
Citric acid 10%	Phosphoric acid 10%
Diesel	Sea water
Distilled water	Sodium chloride 2%
Edible oil	Sodium chloride 20%
Fuel oil	Sulphuric acid 20%
Hydrogen peroxide 3%	Tap water

The powder paint shows limited resistance to the following chemicals at room temperature:

Butanol	Nitric acid 3%
Hydrochloric acid 5%	Nitric acid 10%
Isopropyl alcohol	Phosphoric acid 43%
Na-hypochlorite 10%	Turpentine

Note:

If exposure to any of the above chemicals is demanded, it is recommended to first test the chemical in a hidden spot of the metal casing.

The powder paint shows little or no resistance to the following chemicals at room temperature:

Acetic acid, conc.	Methyl-ethyl ketone	Toluene
Acetone	Nitric acid 30%	Trichlorethylene
Ammonia 5%	Phenol	Xylene
Ammonia, conc.	Sodium hydroxide 5%	97 octane unleaded petrol
Ethyl acetate	Sodium hydroxide 30%	98 octane leaded petrol

5.2 Touch Screen and Overlay

5.2.1 Autotex F157/207

Autotex F157 or F207 covers the overlay surrounding the touch screen.

Solvent Resistance

Autotex F157/F207 withstands exposure of more than 24 hours duration under DIN 42 115 Part 2 to the following chemicals without visible change:

Acetonitrile	Diesel Downey / Lenor ⁽¹⁾	Phosphoric acid (<30%)
Ajax / Vim in solution	Ethanol	Potassium ferricyanide
Alkal carbonate solution ⁽¹⁾	Glycerine	Potassium hydroxide (<30%)
Ammonia (<40%) ⁽¹⁾	Glycol	Pure Turpentine
Acetic acid (<50%)	Gumtion ⁽¹⁾	SBP 60/95 ⁽¹⁾
Ariel powder in solution ⁽¹⁾	Hydrochloric acid (<36%)	Sulfuric acid (<10%)
Bleach ⁽¹⁾	Linseed oil	Tomato ketchup
Castor oil	Methanol	Trichloroacetic acid (<50%)
Caustic soda (<40%) ⁽¹⁾	Nitric acid (<10%)	White Spirit
Cutting oil	Paraffin oil	Windex ⁽¹⁾
Cyclohexanol	Persil powder in solution ⁽¹⁾	Wisk
Diacetone alcohol	Petroleum spirit ⁽¹⁾	-

⁽¹⁾ Extremely faint glossing of the texture was noted.

Autotex withstands DIN 42 115 Part 2 exposure of up to 1 hour duration to glacial acetic acid without visible change.

Autotex is not resistant to high pressure steam at over 100 °C or the following chemicals:

Concentrated mineral acids	Benzyl alcohol
Concentrated caustic solution	Methylene chloride

5.2.2 Touch Screen Surface

The touch screen surface on the operator panel withstands exposure to the following solvents without visible change:

Solvents	Time
Acetone	10 minutes
Isopropanol	10 minutes
Toluene	5 hours

5.2.3 Autotex

It is recommended to use the Autoflex EBA 180L touch display protection film, that can be ordered from Kollmorgen.

Solvent Resistance

Autoflex EBA 180L withstands exposure to the same chemicals as Autotex F157 or F207 according to section [Autotex F157/207](#).

Outdoor Use

In common with all polyester based films, Autoflex EBA 180L is not suitable for use in conditions of long-term exposure to direct sunlight.

6 Operator Panel Drawings

6.1 Connectors

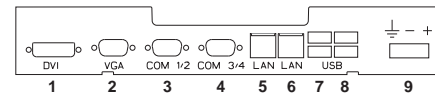

Pos.	Connector	Description
1	DVI	External monitor
2	VGA	External monitor
3	COM 3/4	Communication Ports
4	COM 1/2	Communication Ports
5	LAN Port B	1 × 10/100/1000 Base-T (shielded RJ-45); Intel 82574
6	LAN Port A	1 × 10/100/1000 Base-T (shielded RJ-45); Intel 82559
7	USB	2 × USB Host 2.0, max output current 500 mA
8	USB	2 × USB Host 2.0, max output current 500 mA
9	Power supply	DC input range: 18-32 V DC (140 W) ATX standard

6.2 Communication Ports

Pin	Serial port, 9-pin female		Serial port, 9-pin female	
	COM1	COM2	COM3	COM4
1	-	RS422 Tx+ RS485 Tx+/Rx+	-	RS422 Tx+ RS485 Tx+/Rx+
2	RS232 Rx D	-	RS232 Rx D	-
3	RS232 Tx D	-	RS232 Tx D	-
4	-	RS422 Rx+	-	RS422 Rx+
5	GND	GND	GND	GND
6	-	RS422 Tx- RS485 Tx-/Rx-	-	RS422 Tx- RS485 Tx-/Rx-
7	RS232 RTS	-	-	RS422 RTS+
8	RS232 CTS	-	-	RS422 RTS-
9	-	RS422 Rx-	-	RS422 Rx-

Note: RS422 Interface is not available yet.

6.3 AKI-CDC-MOD-12T Outline

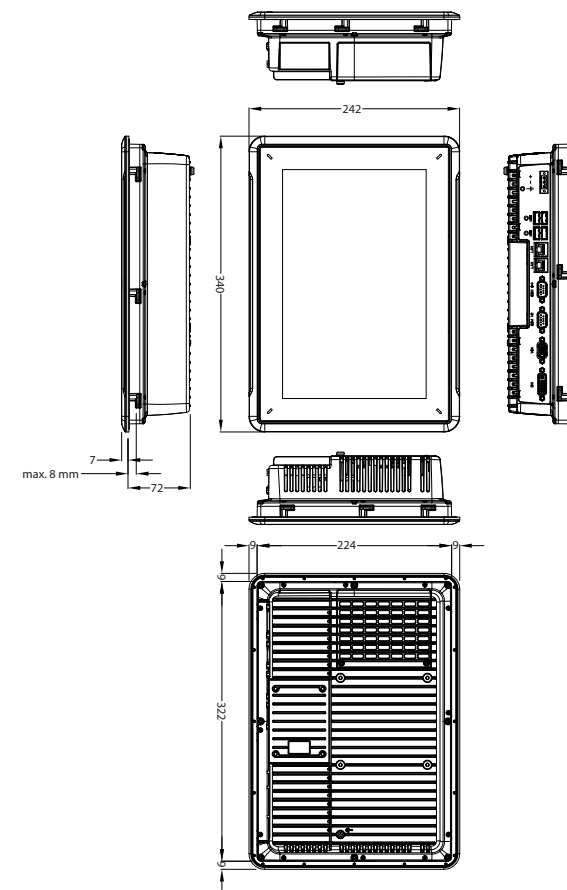

Order no: AKI-CDC-MOD-12T Quick Start Guide
Copyright © September 2013 Kollmorgen. All rights reserved.

Technical changes which improve the performance of the device may be made without prior notice! Printed in the United States of America. This document is the intellectual property of Kollmorgen™. All rights reserved. No part of this work may be reproduced in any form (by photocopying, microfilm or any other method) or stored, processed, copied or distributed by electronic means without the written permission of Kollmorgen™.

KOLLMORGEN

Because Motion Matters™

North America

KOLLMORGEN
203A West Rock Road
Radford, VA 24141 USA
Web: www.kollmorgen.com
Mail: support@kollmorgen.com
Tel.: +1 - 540 - 633 - 3545
Fax: +1 - 540 - 639 - 4162

Europe

KOLLMORGEN Europe GmbH
Pempelfurtstrasse 1
40880 Ratingen, Germany
Web: www.kollmorgen.com
Mail: technik@kollmorgen.com
Tel.: +49 - 2102 - 9394 - 0
Fax: +49 - 2102 - 9394 - 3155

Asia

KOLLMORGEN
Rm 2205, Scitech Tower
22 Jianguomen Wai Street, China
Web: www.kollmorgen.com
Mail: sales.asia@kollmorgen.com
Tel.: +86 - 400 666 1802
Fax: +86 - 106 515 0263