

# AKI-CDA-MOD-07T Installation Guide

## 1 General

### 1.1 About This Manual

All Advanced Kollmorgen Interfaces are developed to satisfy the demands of human-machine communication. Built-in functions such as displaying and controlling text, dynamic indication, time channels, alarm and recipe handling are included.

The Advanced Kollmorgen Interfaces works primarily in an object-oriented way, making it easy to understand and use. Configuration is carried out on a PC using the Kollmorgen Visualization Builder configuration tool. The project can then be transferred and stored in the operator panel itself.

Various types of automation equipment such as PLCs, servos or drives can be connected to the Advanced Kollmorgen Interfaces. In this manual, the term “the controller” refers to the connected equipment.

This manual explains how to install the operator panel. Please refer to the Kollmorgen Visualization Builder **Programming and Installation** manual for further information.

## 2 Safety Precautions

Both the installer and the owner and/or operator of the operator panel must read and understand this installation manual.

### 2.1 General

- Read the safety precautions carefully.
- Check the delivery for transportation damage. If damage is found, notify the supplier as soon as possible.
- The supplier is not responsible for modified, altered or reconstructed equipment.
- Use only parts and accessories manufactured according to specifications of the supplier.
- Read the installation and operating instructions carefully before installing, using or repairing the HMI panel.
- Never allow fluids, metal filings or wiring debris to enter any openings in the HMI panel. This may cause fire or electrical shock.
- Only qualified personnel may operate the HMI panel.
- Storing the HMI panel where the temperature is lower/higher than recommended in this manual can cause the LCD display liquid to congeal/become isotopic.
- The LCD display liquid contains a powerful irritant. In case of skin contact, wash immediately with plenty of water. In case of eye contact, hold the eye open, flush with plenty of water and get medical attention.
- The figures in this manual serves an illustrative purpose. Because of the many variables associated with any particular installation, the supplier cannot assume responsibility for actual use based on the figures.
- The supplier neither guarantees that the HMI panel is suitable for your particular application, nor assumes responsibility for your product design, installation or operation.
- It is recommended to turn on and shut down the HMI panel at least once before installing any components/cards or before connecting the operator panel to external devices, like for example serial devices.

### 2.2 UL and cUL Installation

#### Caution:

This section is only valid for UL labeled AKI-CDA-MOD-07T panels.

- This equipment is suitable for use in Class 2 non-hazardous locations only. [Combinations of equipment in your system are subject to investigation by the local authority having jurisdiction at the time of installation].
- All devices have to be supplied by a Class 2 power supply.



#### Warning:

Do not disconnect equipment unless power has been removed or the area is known to be non-hazardous  
AVANT DE DECONNECTER L'EQUIPEMENT, COUPER LE COURANT  
OUS' ASSURER QUE L'EMPLACEMENT EST DESIGNÉ NON DANGEREUX.



#### Warning:

Only UL and cUL approved expansion units are allowed to be connected to the port designated “EXPANSION”. At the moment there are no such units evaluated or allowed.  
SEULES LES UNITÉS D'EXTENSION CERTIFIÉES UL ET  
CUL PEUVENT ÊTRE RACCORDÉES AU PORT DÉSIGNÉ « EXPANSION ». À L'HEURE ACTUELLE, AUCUNE UNITÉ DE CE TYPE N'A ÉTÉ TESTÉE OU AUTORISÉE.



#### Warning:

Do not replace expansion unit unless power has been switched off or the area is known to be non-hazardous.  
NE REMPLACEZ L'UNITÉ D'EXTENSION QUE SI LE  
COURANT A ÉTÉ COUPÉ OU SI LA ZONE EST JUGÉE NON DANGEREUSE.

- This product contains a battery; this must only be changed in an area known to be non-hazardous.
- Replace the battery with a BR 2032 battery. Use of another type of battery may present a risk of fire or explosion.



#### Warning:

Battery may explode if mistreated. Do not recharge, disassemble or dispose of in fire.  
LA BATTERIE PEUT EXPLOSER EN CAS DE MAUVAISE MANIPULATION.  
NE LA RECHARGEZ PAS, NE LA DÉMONTÉZ PAS ET NE LA JETÉZ PAS DANS LE FEU.

- For use on a flat surface of a type 4X enclosure indoor use only.
- Use minimum 75°C copper conductors only.
- To make wiring connections to the power supply connector, follow the table with cable and torque specifications below:

Terminal Block Connector	Wire Size	TQLb.In.
X1/X100 Phoenix connectors	AWG 30-12	5-7
X1/X100 Anytek connectors	AWG 24-12	3.5

- These devices are Class 2 supplied programmable controllers (industrial PCs) for the use in industrial control equipment and are intended to be (front) panel mounted (Type 1 and 4x for indoor use only).

#### Caution:

The enclosure provides a degree of protection of at least IP20, but when installed in an apparatus, it should meet IP54.  
LE BOÎTIER OFFRE UN DEGRÉ DE PROTECTION D'AU MOINS IP20, MAIS LORSQU'IL EST INSTALLÉ DANS UN APPAREIL, IL DOIT ÊTRE DE CLASSE IP54.

### 2.3 During Installation

- The HMI panel is designed for stationary installation on a plane surface, where the following conditions are fulfilled:
  - no high explosive risks
  - no strong magnetic fields
  - no direct sunlight
  - no large, sudden temperature changes
- Install the HMI panel according to the accompanying installation instructions.
- Ground the HMI panel according to the accompanying installation instructions.
- Only qualified personnel may install the HMI panel.
- Separate the high voltage, signal and supply cables.
- Make sure that the voltage and polarity of the power source is correct before connecting the HMI panel to the power outlet.
- Peripheral equipment must be appropriate for the application and location.

### 2.4 During Use

- Keep the HMI panel clean.
- Emergency stop and other safety functions may not be controlled from the HMI panel.
- Do not use excessive force or sharp objects when operating the touchscreen.

### 2.5 Service and Maintenance

- Only qualified personnel should carry out repairs.
- The agreed warranty applies.
- Before carrying out any cleaning or maintenance operations, disconnect the equipment from the electrical supply.
- Clean the display and surrounding front cover with a soft cloth and mild detergent.
- Replacing the battery incorrectly may result in explosion. Only use batteries recommended by the supplier. During the warranty period, the battery needs to be replaced by an authorized Kollmorgen service center.

### 2.6 Dismantling and Scrapping

- The HMI panel or parts thereof shall be recycled according to local regulations.
- The following components contain substances that might be hazardous to health and the environment: lithium battery, electrolytic capacitor and display.

### 2.7 Appearance of Air in Touch Screen

The layer structure of the touch screen contains air and in rare cases appearance of bubbles can arise. This is purely cosmetic and does not affect any functionality of the HMI panel. The appearance can occur under certain environmental conditions such as temperature, humidity, and atmospheric pressure.

## 3 Installation

### 3.1 Space Requirements

- Maximum installation plate thickness: 11 mm
- Space requirements in millimeters when installing the operator panel:

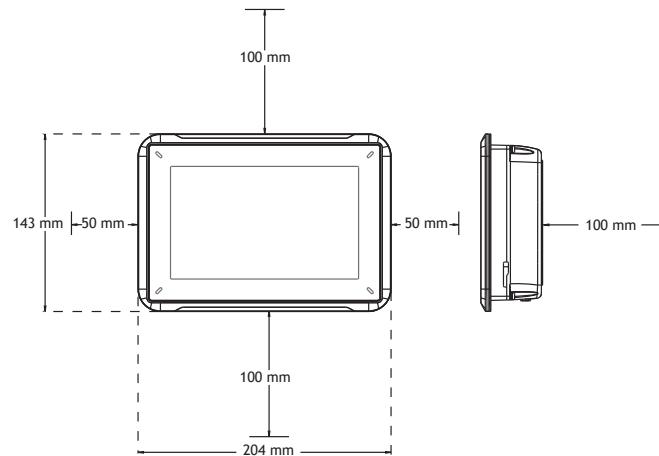

#### Note:

The dimensions on the drawing are not proportional.

### 3.2 Installation Process

The following is needed:

- A Phillips/slot screwdriver

1. Unpack and check the delivery. If damage is found, notify the supplier.

#### Note:

Place the HMI panel on a stable surface during installation. Dropping the HMI panel or letting it fall may cause damage.

2. To cut a correct opening for the HMI panel, use the cut out dimensions in the outline drawing. For more information, see sections [Operator Panel Drawings](#) and [Technical Data](#).
3. Secure the HMI panel in position using all the fastening holes and the provided brackets and screws:

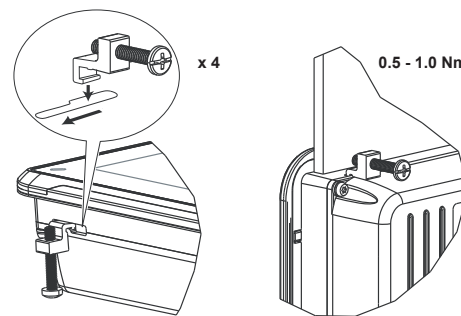

4. Connect the cables in the specified order, according to the drawing and steps below.

#### Caution:

- The HMI panel must be brought to ambient temperature before it is started up. If condensation forms, ensure that the HMI panel is dry before connecting it to the power outlet.
- Ensure that the HMI panel and the controller system have the same electrical grounding (reference voltage level), otherwise errors in communication may occur.
- Ensure that the voltage and polarity of the power source is correct.
- Separate high voltage cables from signal and supply cables.
- Shielded communication cables are recommended.

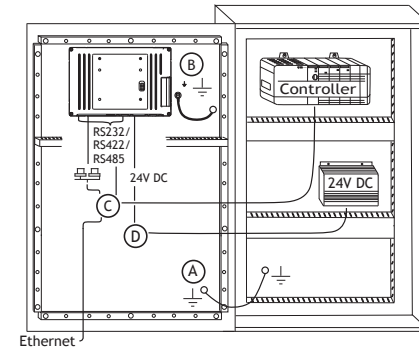

- Connect cable A.
  - Connect cable B, using an M5 screw and a grounding conductor (as short as possible), that is sized correctly according to local electrical codes.
  - Connect cable C.
  - Connect cable D. The recommended cross-section of the cable is 1.5 mm<sup>2</sup>.
5. Carefully remove the laminated film over the HMI panel display, to avoid static electricity that could damage the panel.

#### Note:

When connecting the HMI panel to the power outlet for the first time, make sure not to interrupt power for a minimum of 48 hours in order to charge the battery completely. After that, the battery may be charged partly during a shorter period of time.

### 3.2.1 Connections to the Controller

For information about the cables to be used when connecting the HMI panel to the controller, please refer to the help file for the driver in question.

### 3.2.2 Other Connections and Peripherals

Cables, peripheral equipment and accessories must be suitable for the application and its environment. For further details or recommendations, please refer to the supplier.

## 4 Technical Data

Parameter	AKI-CDA-MOD-07T
Front panel, W × H × D	204 × 143 × 7 mm
Cut out dimensions, W × H	187 × 126 mm
Mounting depth	43 mm (143 mm including clearance)
Standalone mounting	VESA 75 × 75 Note: Maximum screw length for VESA mounting is 4 mm. Usage of longer screws may lead to damage.
Front panel seal	IP 65
Rear panel seal	IP 20
Touch screen material	Polyester on glass, resistive. Overlay: Autoflex EBA 180L <sup>(1)</sup> .
Touch screen operations	1 million finger touch operations
Reverse side material	Powder-coated aluminum
Frame material	Powder-coated aluminum
Weight	0.8 kg

Parameter	AKI-CDA-MOD-07T
Serial port for COM1 RS232 and COM2 RS422/RS485	9-pin D-sub contact with RS232 RTS/CTS, chassis-mounted female with standard locking screws 4-40 UNC
Serial port for COM3 RS232 and COM4 RS422/RS485	9-pin D-sub contact with RS232 RTS/CTS, chassis-mounted female with standard locking screws 4-40 UNC
Ethernet	1 × 10/100 Base-T (shielded RJ45)
USB	1 × USB Host 2.0, max output current 200 mA
Processor	400 MHz ARM9
External storage media	1 × SD card (optional). Only compatible with the standard SD format with up to 2 GB storage capacity.
Flash memory (application memory)	128 MB SSD (NAND Flash)
Memory RAM	128 MB (DDR2)
LED	1 × blue/red software programmable
Real time clock	Yes (on chip)
Battery <sup>(2)</sup>	Lithium battery type BR 2032, soldered
Power consumption at rated voltage	6.0 W
Fuse	Internal DC fuse, 2.0 AT, 5 × 20 mm
Power supply	+24 V DC (18 to 32 V DC) CE: The power supply must conform with the requirements according to IEC 60950 and IEC 61558-2-4. UL and cUL: The power supply must conform with the requirements for class II power supplies.
Display	TFT-LCD with LED backlight. 800 × 480 pixels, 64k colors
Active area of display, W × H	152.4 × 91.4 mm
Operating temperature	-10 °C to +60 °C
Storage temperature	-20 °C to +70 °C
Relative humidity in operation	<85% non-condensed
UL approval	Yes, for UL labeled AKI-CDA-MOD-07T panels, UL 508

## 5 Chemical Resistance

### 5.1 Metal Casing

The frame and casing material is powder-coated aluminum. This powder paint withstands exposure to the following chemicals without visible change:

Acetic acid 10%	Phosphoric acid 4%
Citric acid 10%	Phosphoric acid 10%
Diesel	Sea water
Distilled water	Sodium chloride 2%
Edible oil	Sodium chloride 20%
Fuel oil	Sulphuric acid 20%
Hydrogen peroxide 3%	Tap water

The powder paint shows limited resistance to the following chemicals at room temperature:

Butanol	Nitric acid 3%
Hydrochloric acid 5%	Nitric acid 10%
Isopropyl alcohol	Phosphoric acid 43%
Sodium hypochlorite 10%	Turpentine

#### Note:

If exposure to any of the above chemicals is demanded, it is recommended to first test the chemical in a hidden spot of the metal casing.

The powder paint shows little or no resistance to the following chemicals at room temperature:

Acetic acid, conc.	Methyl-ethyl ketone	Toluene
Acetone	Nitric acid 30%	Trichlorethylene
Ammonia 5%	Phenol	Xylene
Ammonia, conc.	Sodium hydroxide 5%	97 octane unleaded petrol
Ethyl acetate	Sodium hydroxide 30%	98 octane leaded petrol

### 5.2 Touch Screen and Overlay

#### 5.2.1 Autoflex EBA 180L

Autoflex EBA 180L covers the overlay surrounding the screen.

#### Solvent Resistance

Autoflex EBA 180L withstands exposure of more than 24 hours duration under DIN 42 115 Part 2 to the following chemicals without visible change:

Ajax / Vim in solution	Downy / Lenor <sup>(1)</sup>	Phosphoric acid (<30%)
Alkal carbonate solution <sup>(1)</sup>	Ethanol	Potassium ferricyanide
Ammonia (<40%) <sup>(1)</sup>	Glycerine	Potassium hydroxide (<30%)
Acetic acid (<50%)	Glycol	Pure Turpentine
Ariel powder in solution <sup>(1)</sup>	Gumption <sup>(1)</sup>	SBP 60/95 <sup>(1)</sup>
Bleach <sup>(1)</sup>	Hydrochloric acid (<36%)	Sulfuric acid (<10%)
Castor oil	Linseed oil	Tomato ketchup
Caustic soda (<40%) <sup>(1)</sup>	Methanol	Trichloroacetic acid (<50%)
Cutting oil	Nitric acid (<10%)	White Spirit
Cyclohexanol	Paraffin oil	Windex <sup>(1)</sup>
Diacetone alcohol	Persil powder in solution <sup>(1)</sup>	Wisk
Diesel	Petroleum spirit <sup>(1)</sup>	Acetonitrile

<sup>(1)</sup> Extremely faint glossing of the texture was noted.

Autoflex EBA 180L withstands DIN 42 115 Part 2 exposure of up to 1 hour duration to glacial acetic acid without visible change.

Autoflex EBA 180L is not resistant to high pressure steam at over 100 °C or the following chemicals:

Concentrated mineral acids	Benzyl alcohol
Concentrated caustic solution	Methylene chloride

#### 5.2.2 Touch Screen Surface

The touch screen surface on the operator panel withstands exposure to the following solvents without visible change:

Solvents	Time
Acetone	10 minutes
Isopropanol	10 minutes
Toluene	5 hours

#### 5.2.3 Touch Screen Protection Film

##### Autoflex EBA 180L

It is recommended to use the Autoflex EBA 180L protection film that can be ordered from Kollmorgen.

#### Solvent Resistance

The chemical resistance for Autoflex EBA 180L is described in section [Autoflex EBA 180L](#).

#### Outdoor Use

In common with all polyester based films, Autoflex EBA 180L is not suitable for use in conditions of long-term exposure to direct sunlight.

## 6 Operator Panel Drawings

### 6.1 Connectors

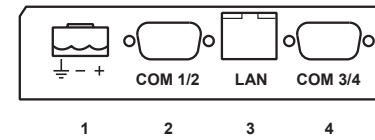

Pos.	Connector	Description
1	Power supply	+24 V DC (18-32 V DC)
2	COM 1/2	Communication Ports
3	LAN	1 × 10/100 Base-T (shielded RJ45)
4	COM 3/4	Communication Ports

### 6.2 Communication Ports

Pin	Serial port, 9-pin female		Serial port, 9-pin female	
	COM1	COM2	COM3	COM4
1	-	RS422 Tx+ RS485 Tx+ / Rx+	-	RS422 Tx+ RS485 Tx+ / Rx+
2	RS232 Rx D	-	RS232 Rx D	-
3	RS232 Tx D	-	RS232 Tx D	-
4	-	RS422 Rx+	-	RS422 Rx+
5	GND	GND	GND	GND
6	-	RS422 Tx- RS485 Tx- / Rx-	-	RS422 Tx- RS485 Tx- / Rx-
7	RS232 RTS	-	-	RS422 RTS+
8	RS232 CTS	-	-	RS422 RTS-
9	-	RS422 Rx-	-	RS422 Rx-

### 6.3 AKI-CDA-MOD-07T Outline

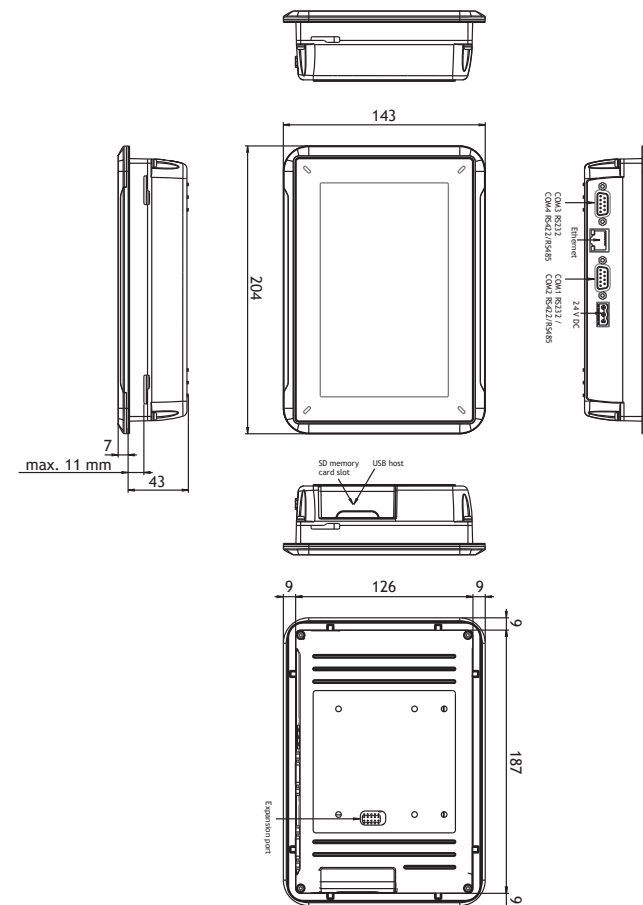

Order no: AKI-CDA-MOD-07T Quick Start Guide  
Copyright © October 2014 Kollmorgen. All rights reserved.

Technical changes which improve the performance of the device may be made without prior notice! Printed in the United States of America. This document is the intellectual property of Kollmorgen™. All rights reserved. No part of this work may be reproduced in any form (by photocopying, microfilm or any other method) or stored, processed, copied or distributed by electronic means without the written permission of Kollmorgen™.

**KOLLMORGEN**

Because Motion Matters™

#### North America

**KOLLMORGEN**  
203A West Rock Road  
Radford, VA 24141 USA  
Web: [www.kollmorgen.com](http://www.kollmorgen.com)  
Mail: [support@kollmorgen.com](mailto:support@kollmorgen.com)  
Tel.: +1 - 540 - 633 - 3545  
Fax: +1 - 540 - 639 - 4162

#### Europe

**KOLLMORGEN Europe GmbH**  
Pempelfurtstrasse 1  
40880 Ratingen, Germany  
Web: [www.kollmorgen.com](http://www.kollmorgen.com)  
Mail: [technik@kollmorgen.com](mailto:technik@kollmorgen.com)  
Tel.: +49 - 2102 - 9394 - 0  
Fax: +49 - 2102 - 9394 - 3155

#### Asia

**KOLLMORGEN**  
Rm 2205, Scitech Tower  
22 Jianguomen Wai Street, China  
Web: [www.kollmorgen.com](http://www.kollmorgen.com)  
Mail: [sales.asia@kollmorgen.com](mailto:sales.asia@kollmorgen.com)  
Tel.: +86 - 400 666 1802  
Fax: +86 - 106 515 0263