

Graphic Operator Terminal Installation Manual



Edition B, October 2014

AKI-CDB-MOD-15T 15" Touchscreen HMI



Keep all manuals as a product component during the life span of the product.
Pass all manuals to future users / owners of the product.

KOLLMORGEN

Because Motion Matters™

Record of Document Revisions

Revision	Remarks
A, 07/2013	Preliminary edition
B, 10/2014	Updated UL information

Hardware Revision

Revision	Firmware revision	Software revision	Remarks
06/2013	b0208	2.0-SP1	Initial release
10/2014	b0244	2.10	

IMPORTANT NOTICE

Technical changes which improve the performance of the device may be made without prior notice!

Printed in the United States of America. This document is the intellectual property of Kollmorgen™. All rights reserved. No part of this work may be reproduced in any form (by photocopying, microfilm or any other method) or stored, processed, copied or distributed by electronic means without the written permission of Kollmorgen™.

1 General	
1.1 About This Manual	4
2 Safety Precautions	
2.1 General	5
2.2 UL and cUL Installation	5
2.3 During Installation	6
2.4 During Use	7
2.5 Service and Maintenance	7
2.6 Dismantling and Scrapping	7
2.7 Appearance of Air in Touch Screen	7
3 Installation	
3.1 Space Requirements	8
3.2 Installation Process	9
3.2.1 Connections to the Controller	10
3.2.2 Other Connections and Peripherals	10
4 Technical Data	
5 Chemical Resistance	
5.1 Metal Casing	13
5.2 Touch Screen and Overlay	14
5.2.1 Autoflex EBA 180L	14
5.2.2 Touch Screen Surface	14
5.2.3 TouchKeyboard and Screen Protection Film	15
6 Operator Panel Drawings	
6.1 Connectors	16
6.2 Communication Ports	16
6.3 AKI-CDB-MOD-15T Outline	17
7 Additional Installation Tips	
7.1 Grounding the Operator Panel	18
7.2 Ethernet Connection in the Operator Panel	19
7.3 To Achieve Better EMC Protection	20
7.4 Ambient Temperature	21
7.5 Safety	22
7.6 Galvanic Isolation	23
7.7 Cable and Bus Termination RS485	24

1 GENERAL

1.1 About This Manual

All Advanced Kollmorgen Interfaces are developed to satisfy the demands of human-machine communication. Built-in functions such as displaying and controlling text, dynamic indication, time channels, alarm and recipe handling are included.

The Advanced Kollmorgen Interfaces works primarily in an object-oriented way, making it easy to understand and use. Configuration is carried out on a PC using the Kollmorgen Visualization Builder configuration tool. The project can then be transferred and stored in the operator panel itself.

Various types of automation equipment such as PLCs, servos or drives can be connected to the Advanced Kollmorgen Interfaces. In this manual, the term “the controller” refers to the connected equipment.

This manual explains how to install the operator panel. Please refer to the Kollmorgen Visualization Builder **Programming and Installation** manual for further information.

2 SAFETY PRECAUTIONS

Both the installer and the owner and/or operator of the operator panel must read and understand this installation manual.

2.1 General

- Read the safety precautions carefully.
- Check the delivery for transportation damage. If damage is found, notify the supplier as soon as possible.
- The supplier is not responsible for modified, altered or reconstructed equipment.
- Use only parts and accessories manufactured according to specifications of the supplier.
- Read the installation and operating instructions carefully before installing, using or repairing the HMI panel.
- Never allow fluids, metal filings or wiring debris to enter any openings in the HMI panel. This may cause fire or electrical shock.
- Only qualified personnel may operate the HMI panel.
- Storing the HMI panel where the temperature is lower/higher than recommended in this manual can cause the LCD display liquid to congeal/become isotopic.
- The LCD display liquid contains a powerful irritant. In case of skin contact, wash immediately with plenty of water. In case of eye contact, hold the eye open, flush with plenty of water and get medical attention.
- The figures in this manual serves an illustrative purpose. Because of the many variables associated with any particular installation, the supplier cannot assume responsibility for actual use based on the figures.
- The supplier neither guarantees that the HMI panel is suitable for your particular application, nor assumes responsibility for your product design, installation or operation.
- It is recommended to turn on and shut down the HMI panel at least once before installing any components/cards or before connecting the operator panel to external devices, like for example serial devices.

2.2 UL and cUL Installation

- This equipment is suitable for use in Class 2 non-hazardous locations only. [Combinations of equipment in your system are subject to investigation by the local authority having jurisdiction at the time of installation].
- All devices have to be supplied by a Class 2 power supply.

⚠ WARNING

Do not disconnect equipment unless power has been removed or the area is known to be non-hazardous
AVANT DE DECONNECTER L'EQUIPEMENT, COUPER LE COURANT
OUS'ASSURER QUE L'EMPLACEMENT EST DESIGNE NON DANGEREUX.

⚠ WARNING

Only UL and cUL approved expansion units are allowed to be connected to the port designated "EXPANSION". At the moment there are no such units evaluated or allowed.
SEULES LES UNITÉS D'EXTENSION CERTIFIÉES UL ET
cUL PEUVENT ÊTRE RACCORDÉES AU PORT DÉSIGNÉ « EXPANSION ».
À L'HEURE ACTUELLE, AUCUNE UNITÉ DE CE TYPE N'A ÉTÉ TESTÉE
OU AUTORISÉE.

⚠ WARNING

Do not replace expansion unit unless power has been switched off or the area is known to be non-hazardous.

NE REMPLACEZ L'UNITÉ D'EXTENSION QUE SI LE COURANT A ÉTÉ COUPÉ OU SI LA ZONE EST JUGÉE NON DANGEREUSE.

- This product contains a battery; this must only be changed in an area known to be non-hazardous.
- Replace the battery with a BR 2032 battery. Use of another type of battery may present a risk of fire or explosion.

⚠ WARNING

Battery may explode if mistreated. Do not recharge, disassemble or dispose of in fire.

LA BATTERIE PEUT EXPLOSER EN CAS DE MAUVAISE MANIPULATION.

NE LA RECHARGEZ PAS, NE LA DÉMONTEZ PAS ET NE LA JETEZ PAS DANS LE FEU.

- For use on a flat surface of a type 4X enclosure indoor use only.
- Use minimum 75°C copper conductors only.
- To make wiring connections to the power supply connector, follow the table with cable and torque specifications below:

Terminal Block Connector	Wire Size	TQ Lb.In.
X1/X100 Phoenix connectors	AWG 30–12	5–7
X1/X100 Anytek connectors	AWG 24–12	3.5

- These devices are Class 2 supplied programmable controllers (industrial PCs) for the use in industrial control equipment and are intended to be (front) panel mounted (Type 1 and 4x for indoor use only).

Caution:

The enclosure provides a degree of protection of at least IP20, but when installed in an apparatus, it should meet IP54.

LE BOÎTIER OFFRE UN DEGRÉ DE PROTECTION D'AU MOINS IP20, MAIS LORSQU'IL EST INSTALLÉ DANS UN APPAREIL, IL DOIT ÊTRE DE CLASSE IP54.

2.3 During Installation

- The HMI panel is designed for stationary installation on a plane surface, where the following conditions are fulfilled:
 - no high explosive risks
 - no strong magnetic fields
 - no direct sunlight
 - no large, sudden temperature changes
- Install the HMI panel according to the accompanying installation instructions.
- Ground the HMI panel according to the accompanying installation instructions.
- Only qualified personnel may install the HMI panel.
- Separate the high voltage, signal and supply cables.

- Make sure that the voltage and polarity of the power source is correct before connecting the HMI panel to the power outlet.
- Peripheral equipment must be appropriate for the application and location.

2.4 During Use

- Keep the HMI panel clean.
- Emergency stop and other safety functions may not be controlled from the HMI panel.
- Do not use excessive force or sharp objects when operating the touchscreen.

2.5 Service and Maintenance

- Only qualified personnel should carry out repairs.
- The agreed warranty applies.
- Before carrying out any cleaning or maintenance operations, disconnect the equipment from the electrical supply.
- Clean the display and surrounding front cover with a soft cloth and mild detergent.
- Replacing the battery incorrectly may result in explosion. Only use batteries recommended by the supplier. During the warranty period, the battery needs to be replaced by an authorized Kollmorgen service center.

2.6 Dismantling and Scrapping

- The HMI panel or parts thereof shall be recycled according to local regulations.
- The following components contain substances that might be hazardous to health and the environment: lithium battery, electrolytic capacitor and display.

2.7 Appearance of Air in Touch Screen

The layer structure of the touch screen contains air and in rare cases appearance of bubbles can arise. This is purely cosmetic and does not affect any functionality of the HMI panel. The appearance can occur under certain environmental conditions such as temperature, humidity, and atmospheric pressure.

3 INSTALLATION

3.1 Space Requirements

- Maximum installation plate thickness: 8 mm
- Space requirements in millimeters when installing the operator panel:

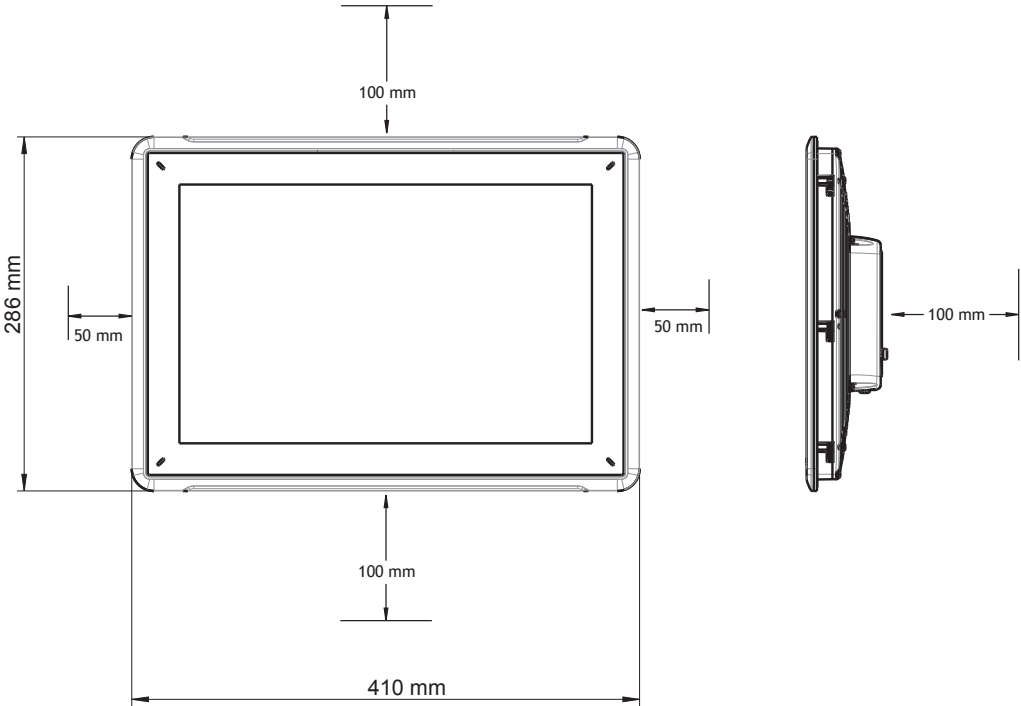

Note:
The dimensions on the drawing are not proportional.

3.2 Installation Process

The following is needed:

- A Torx TX7 screwdriver

1. Unpack and check the delivery. If damage is found, notify the supplier.

Note:

Place the HMI panel on a stable surface during installation.
Dropping the HMI panel or letting it fall may cause damage.

2. To cut a correct opening for the HMI panel, use the cut out dimensions in the outline drawing. For more information, see sections [Operator Panel Drawings](#) and [Technical Data](#).
3. Secure the HMI panel in position by screwing the M4 Torx screw, allowing the built-in bracket to tighten against the panel:

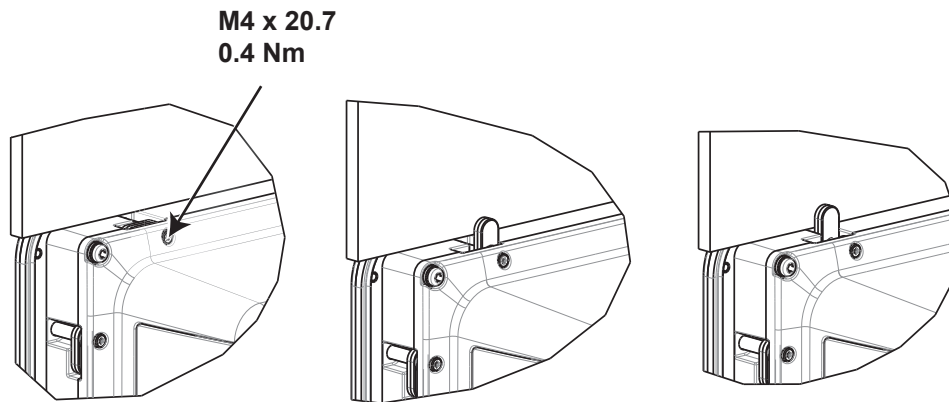
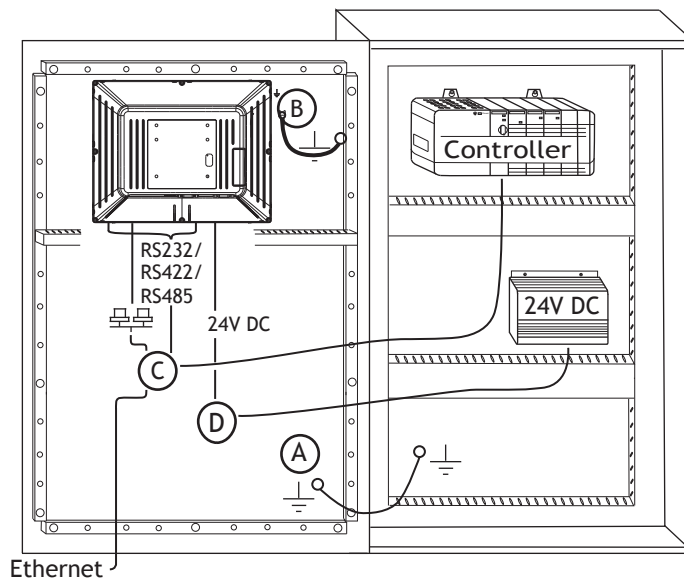

Figure 3-1: A. M4 x 20.7, 0.4 Nm

4. Connect the cables in the specified order, according to the drawing and steps below.

Caution:

- The HMI panel must be brought to ambient temperature before it is started up. If condensation forms, ensure that the HMI panel is dry before connecting it to the power outlet.
- Ensure that the HMI panel and the controller system have the same electrical grounding (reference voltage level), otherwise errors in communication may occur.
- Ensure that the voltage and polarity of the power source is correct.
- Separate high voltage cables from signal and supply cables.
- Shielded communication cables are recommended.



- Connect cable A.
 - Connect cable B, using an M5 screw and a grounding conductor (as short as possible), that is sized correctly according to local electrical codes.
 - Connect cable C.
 - Connect cable D. The recommended cross-section of the cable is 1.5 mm².
5. Carefully remove the laminated film over the HMI panel display, to avoid static electricity that could damage the panel.

3.2.1 Connections to the Controller

For information about the cables to be used when connecting the HMI panel to the controller, please refer to the help file for the driver in question.

3.2.2 Other Connections and Peripherals

Cables, peripheral equipment and accessories must be suitable for the application and its environment. For further details or recommendations, please refer to the supplier.

4 TECHNICAL DATA

Parameter	AKI-CDB-MOD-15T
Front panel, W × H × D	410 × 286 × 83 mm
Cut out dimensions, W × H	394 × 270 mm
Mounting depth	76 mm (176 mm including clearance)
Standalone mounting	VESA 75 × 75 Note: Maximum screw length for VESA mounting is 4 mm. Usage of longer screws may lead to damage.
Front panel seal	IP 65
Rear panel seal	IP 20
Touch screen material	Polyester on glass, resistive. Overlay: Autoflex EBA 180L ⁽¹⁾ .
Touch screen operations	1 million finger touch operations
Reverse side material	Powder-coated aluminum
Frame material	Powder-coated aluminum
Weight	3.85 kg
Serial port for COM1 RS232 and COM2 RS422/RS485	9-pin D-sub contact with RS232 RTS/CTS, chassis-mounted female with standard locking screws 4-40 UNC
Serial port for COM3 RS232 and COM4 RS422/RS485	9-pin D-sub contact with RS232 RTS/CTS, chassis-mounted female with standard locking screws 4-40 UNC
Ethernet	1 x 10/100/1000 Base-T (shielded RJ45)
USB	3 × USB Host 2.0, max output current 500 mA
Processor	Intel® Atom
External storage media	1 × SD card (optional). Only compatible with the standard SD format with up to 2 GB storage capacity.
Memory RAM	1 GB
LED	1 × multi-color
Real time clock	Yes (on chip)
Battery	Lithium battery type BR 2032 (or CR 2032), exchangeable
Power consumption at rated voltage	24 W
Fuse	3.15 A Slow

Parameter	AKI-CDB-MOD-15T
Power supply	+24 V DC (18 to 32 V DC) CE: The power supply must conform with the requirements according to IEC 60950 and IEC 61558-2-4. UL and cUL: The power supply must conform with the requirements for class II power supplies.
Display	TFT-LCD with LED backlight. 1280 × 800 pixels, 262 k colors
Active area of display, W × H	331.2 × 207.0 mm
Operating temperature	-10 °C to +50 °C
Storage temperature	-20 °C to +70 °C
Relative humidity in operation	5% – 85% non-condensed
UL approval	Yes, UL 508

5 CHEMICAL RESISTANCE

5.1 Metal Casing

The frame and casing material is powder-coated aluminum. This powder paint withstands exposure to the following chemicals without visible change:

Acetic acid 10%	Phosphoric acid 4%
Citric acid 10%	Phosphoric acid 10%
Diesel	Sea water
Distilled water	Sodium chloride 2%
Edible oil	Sodium chloride 20%
Fuel oil	Sulphuric acid 20%
Hydrogen peroxide 3%	Tap water

The powder paint shows limited resistance to the following chemicals at room temperature:

Butanol	Nitric acid 3%
Hydrochloric acid 5%	Nitric acid 10%
Isopropyl alcohol	Phosphoric acid 43%
Sodium hypochlorite 10%	Turpentine

Note:

If exposure to any of the above chemicals is demanded, it is recommended to first test the chemical in a hidden spot of the metal casing.

The powder paint shows little or no resistance to the following chemicals at room temperature:

Acetic acid, conc.	Methyl-ethyl ketone	Toluene
Acetone	Nitric acid 30%	Trichlorethylene
Ammonia 5%	Phenol	Xylene
Ammonia, conc.	Sodium hydroxide 5%	97 octane unleaded petrol
Ethyl acetate	Sodium hydroxide 30%	98 octane leaded petrol

5.2 Touch Screen and Overlay

5.2.1 Autoflex EBA 180L

Autoflex EBA 180L covers the overlay surrounding the screen.

Solvent Resistance

Autoflex EBA 180L withstands exposure of more than 24 hours duration under DIN 42 115 Part 2 to the following chemicals without visible change:

Ajax / Vim in solution	Downy / Lenor ⁽¹⁾	Phosphoric acid (<30%)
Alkalicarbonate solution ⁽¹⁾	Ethanol	Potassium ferricyanide
Ammonia (<40%) ⁽¹⁾	Glycerine	Potassium hydroxide (<30%)
Acetic acid (<50%)	Glycol	Pure Turpentine
Ariel powder in solution ⁽¹⁾	Gumption ⁽¹⁾	SBP 60/95 ⁽¹⁾
Bleach ⁽¹⁾	Hydrochloric acid (<36%)	Sulfuric acid (<10%)
Castor oil	Linseed oil	Tomato ketchup
Caustic soda (<40%) ⁽¹⁾	Methanol	Trichloroacetic acid (<50%)
Cutting oil	Nitric acid (<10%)	White Spirit
Cyclohexanol	Paraffin oil	Windex ⁽¹⁾
Diacetone alcohol	Persil powder in solution ⁽¹⁾	Wisk
Diesel	Petroleum spirit ⁽¹⁾	Acetonitrile

⁽¹⁾Extremely faint glossing of the texture was noted.

Autoflex EBA 180L withstands DIN 42 115 Part 2 exposure of up to 1 hour duration to glacial acetic acid without visible change.

Autoflex EBA 180L is not resistant to high pressure steam at over 100 °C or the following chemicals:

Concentrated mineral acids	Benzyl alcohol
Concentrated caustic solution	Methylene chloride

5.2.2 Touch Screen Surface

The touch screen surface on the operator panel withstands exposure to the following solvents without visible change:

Solvents	Time
Acetone	10 minutes
Isopropanol	10 minutes
Toluene	5 hours

5.2.3 TouchKeyboard and Screen Protection Film

Autoflex EBA 180L

It is recommended to use the Autoflex EBA 180L protection film that can be ordered from Kollmorgen.

Solvent Resistance

The chemical resistance for Autoflex EBA 180L is described in section [Autoflex EBA 180L](#).

Outdoor Use

In common with all polyester based films, Autoflex EBA 180L is not suitable for use in conditions of long-term exposure to direct sunlight.

Note:

The layer structure of the touch screen contains air and in rare cases appearance of bubbles can arise. This is purely cosmetic and does not affect any functionality of the panel. The appearance can occur under certain environmental conditions such as temperature, humidity, and atmospheric pressure.

6 OPERATOR PANEL DRAWINGS

6.1 Connectors

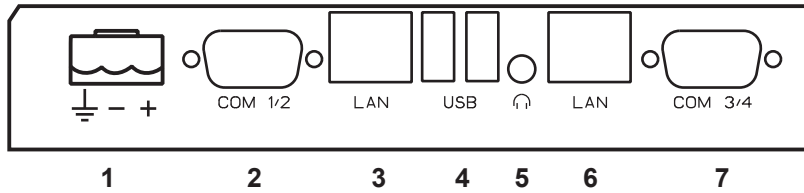

Pos.	Connector	Description
1	Power supply	+24 V DC (18-32 V DC)
2	COM 1/2	Communication Ports
3	LAN (Port 2)	1 × 10/100 Base-T (shielded RJ45)
4	USB	2 × USB Host 2.0, max output current 500 mA
5	Headphone	Headphone Connector
6	LAN (Port 1)	1 x 10/100/1000 Base-T (shielded RJ45)
7	COM 3/4	Communication Ports

6.2 Communication Ports

Pin	Serial port, 9-pin female		Serial port, 9-pin female	
	COM1	COM2	COM3	COM4
1	-	RS422 Tx+ RS485 Tx+/Rx+	-	RS422 Tx+ RS485 Tx+/Rx+
2	RS232 RxD	-	RS232 RxD	-
3	RS232 TxD	-	RS232 TxD	-
4	-	RS422 Rx+	-	RS422 Rx+
5	GND	GND	GND	GND
6	-	RS422 Tx- RS485 Tx-/Rx-	-	RS422 Tx- RS485 Tx-/Rx-
7	RS232 RTS	-	-	RS422 RTS+
8	RS232 CTS	-	-	RS422 RTS-
9	-	RS422 Rx-	-	RS422 Rx-

6.3 AKI-CDB-MOD-15T Outline

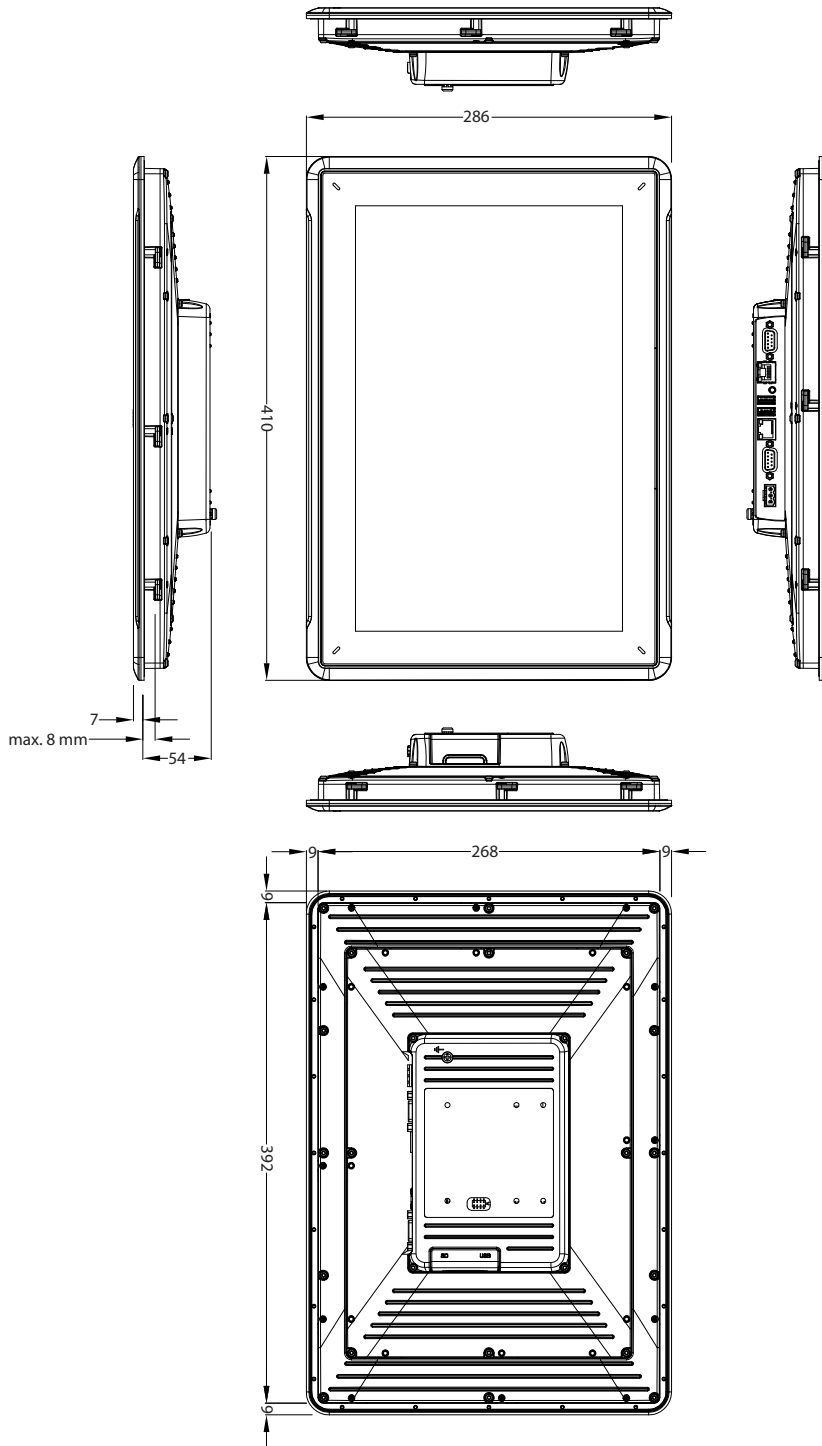

7 ADDITIONAL INSTALLATION TIPS

When experiencing communication problems in for example noisy environments or when operating close to temperature limits, the following recommendations are to be noticed.

7.1 Grounding the Operator Panel

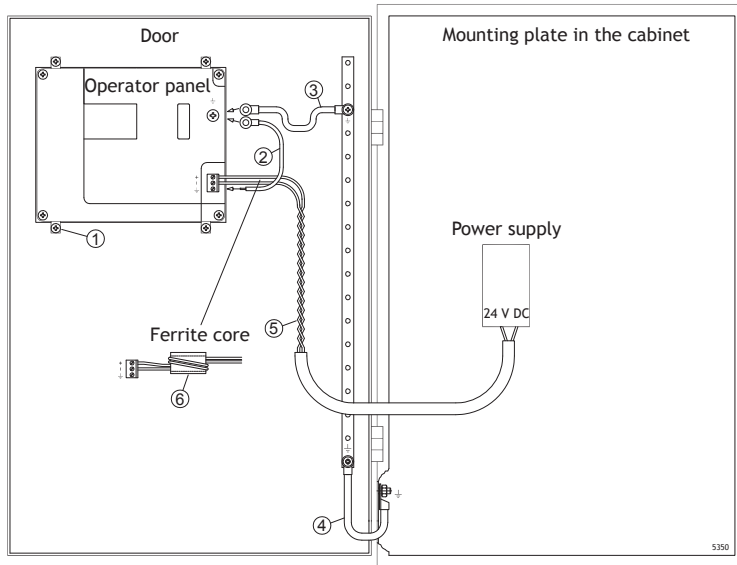

The operator panel's mounting clamps do not provide a secure grounding connection between the panel and the device cabinet, see 1 in drawing above.

1. Connect a wire that is sized correctly according to local electrical codes between the operator panel's quick-connect plinth and the panel's chassis, see 2 in drawing above.
 2. Connect a wire or grounding braid that is sized correctly according to local electrical codes between the operator panel's chassis and the closest grounding point on the door, see 3 in drawing above.
 3. Connect a strong but short grounding braid between the door and the device cabinet, see 4 in drawing above.
 4. Twist the cables onto the 24 V DC feed, see 5 in drawing above.
 - 2 turns around the ferrite core provide 4 times the suppression of 1 turn.
 - 3 turns around the ferrite core provide 9 times the suppression of 1 turn.
- A ferrite core suppresses disturbances to the 24 V feed, see 6 in drawing above.

Note:

The grounding wires should be short and the conductor should have a large area.

A long, thin grounding wire has a very high impedance (resistance) at high frequencies and will not guide disturbances to the ground.

Multi-wire conductors are better than single wire conductors with the same area.

A braided conductor wire with the same area is even better. The best is a short, thick grounding braid.

7.2 Ethernet Connection in the Operator Panel

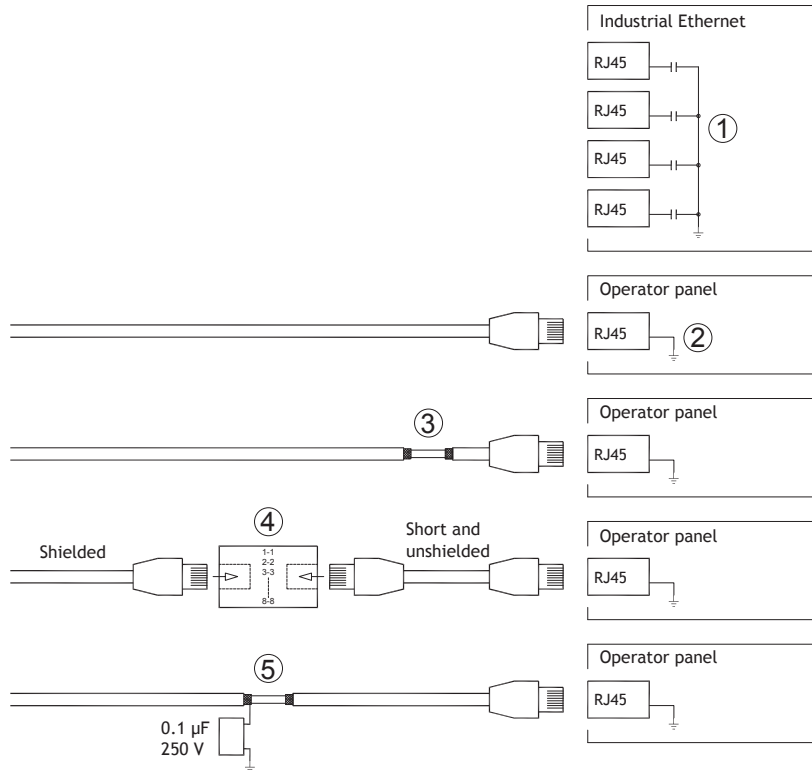

In some industrial units for Ethernet, the RJ45 contact's shield is connected to the chassis via a capacitor, see 1 in drawing above.

The operator panel's Ethernet shield is directly connected to the chassis, see 2 in drawing above.

1. Check whether the other Ethernet unit has its shield directly grounded or grounded via a capacitor.

Note:

In many cases, connecting the shielded Ethernet cabling to the chassis at both ends is inappropriate. Hum or grounding loops can occur. Unshielded cabling may even result in fewer communication errors.

A good solution may be to use a shielded Ethernet cable, but to connect the shield at one end only.

One option is to break the shield, see 3 in drawing above.

A more elegant method is to expand the shielded Ethernet cabling with a piece of unshielded Ethernet cable, see 4 in drawing above.

The shield can be grounded via an external 0.1 μ F/250 V plastic capacitor, see 5 in drawing above. This will connect the HF transients to ground.

7.3 To Achieve Better EMC Protection

- Use shielded cables for RS232 communication.
- Use twisted pair and shielded cabling for RS422 and RS485.
- Use the cabling intended for the bus type; Ethernet, Profibus, CC-Link, CAN, Device Net etc.
- Install and connect according to applicable specifications for the relevant bus standard.
- Use shielded cabling for Ethernet, preferably with foil and a braided shield.
- D-sub covers should be shielded, and the shield should be connected to the cover 360° where the cable enters.
- Connect the shield at both ends.

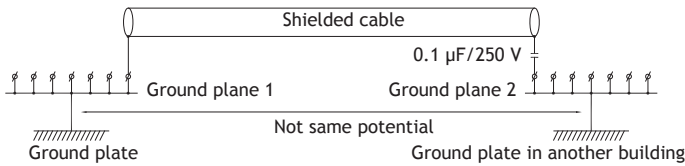

With longer distances, there is a risk that the ground potential may be different. In that case, the shield should only be connected at one end. A good alternative is to connect the other end of the shield to the ground via a 0.1 µF/250 V plastic capacitor. Both ends are then connected to the ground in terms of HF, but only connected to the ground at one end in terms of LF, thus avoiding the 50/60 Hz grounding loops.

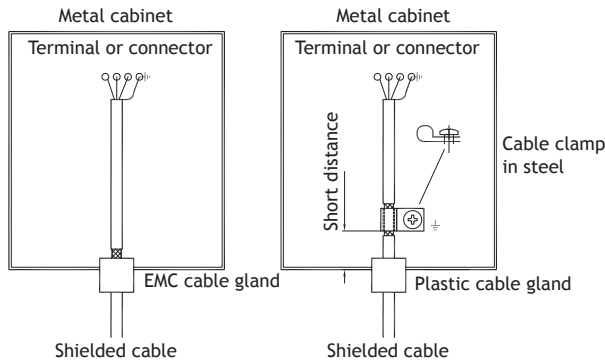

1. Use an EMC cable gland or regular plastic cable gland, remove the outer jacket and connect the shield to the installation plate with a 360° metal cable clamp.
2. Place the 24 V DC and communications cabling in one cable trunk/cable duct and 230/380 V AC in another. If the cables need to be crossed, cross them at 90° only. Avoid combining the cabling for stronger 24 V DC outputs with the communication cabling.

Ferrite cores that are snapped onto the shielded cabling may remove minor disturbances. Large ferrite pieces that are snapped onto unshielded cabling and where the wires go 2-4 times around the cores are approximately 5-25 times more efficient.

7.4 Ambient Temperature

The maximum ambient temperature for the operator panel is provided in the specifications. The ambient temperature refers to the temperature in the device cabinet which cools the operator panel's electronics.

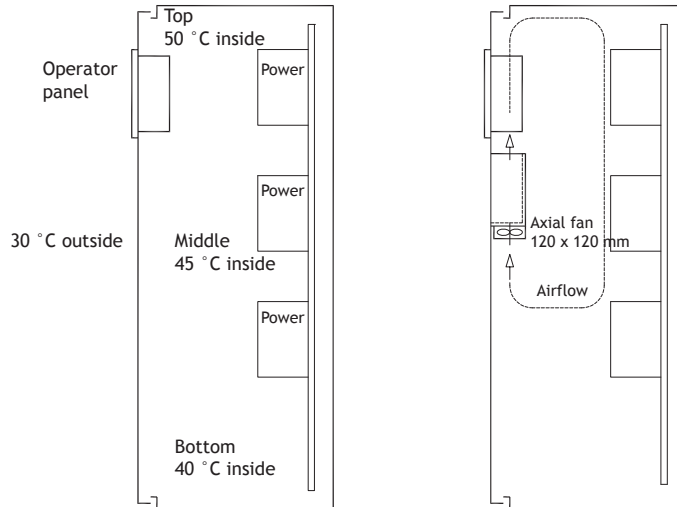

In most cases, the ambient temperature for the operator panel is significantly higher than the device cabinet's ambient temperature.

If the cabinet is tall and there are a number of heat-generating devices, the temperature at the top of the cabinet will be considerably higher than the theoretical temperature increase that would be expected. All electronics are sensitive to heat. The lifespan of an electrolytic capacitor is cut in half with an 8-10 °C increase in temperature. A 15-20 °C temperature increase results in a quarter of the lifespan etc.

Rittal has a good program for estimating the anticipated average temperature in the cabinet as well as a large program for controlling the temperature in the device cabinet.

An enamel-coated steel cabinet has a radiant heat value of 5.5 W/m² and degrees C.

Installing a fan inside the cabinet will even out the temperature, while moving air provides considerably better cooling than still air.

Install the fan so that it sits in the cooler area and blows cold air against the operator panel. If the fan is mounted at the top and sucks warm air upwards, the fan's ambient temperature will be higher, resulting in a shorter lifespan.

The operator panel's loss effect = supply voltage x current. Virtually no power goes to external users and no loss effects due to inputs.

7.5 Safety

Most of the operator panels are fed with 24 V DC.

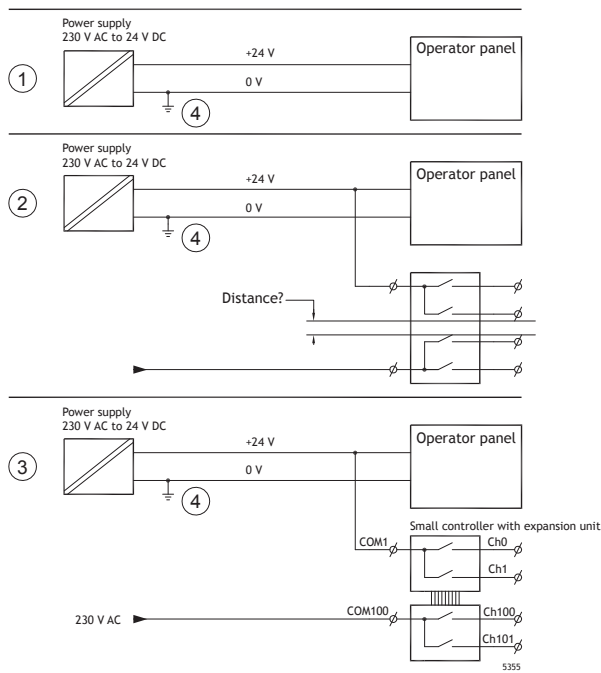

If a power supply that meets safety standards is used and only feeds the operator panel, there is no problem. See 1 in drawing above.

However, if a 24 V unit that also feeds other units is used, there is reason to be cautious, see 2 in drawing above. The operator panel does not have insulation that meets safety requirements in the event of a potential short circuit between 230 V AC and 24 V DC. It is assumed that the 24 V feed is secure, for example, SELV according to EN 60950 (protection against electric shock) and UL 950.

Note:

Here is an example that explains why a secure 24 V DC feed can be ruined by mixing 24 V relay contacts with 230 V AC relay contacts in a smaller controller. Check that the clearances and creepage distances between 24 V DC and 230 V AC fulfill EN 60950 or UL 950. If not, input a separate 24 V unit into the operator panel.

If there is a substantial distance between the relay contacts for 24 V DC and 230 V AC, it is OK to use the same 24 V devices for all feeds. See 3 in drawing above.

Connect 0 V on the 24 V feed to the ground, see 4 in drawing above. This offers three advantages:

- Safety is increased. The 24 V feed will not be live in the event of a faulty connection or short circuit between 0 V (24 V) and 230 V phase.
- Transients on the 24 V feed are connected to the ground.
- No risk that the 24 V feed is at a high level in relationship to the ground. This is not unusual since there is high static electricity.

7.6 Galvanic Isolation

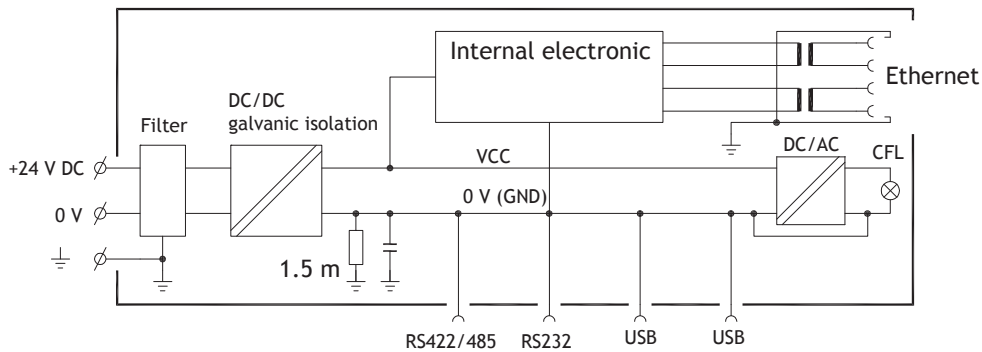

The operator panel has galvanic isolation against the 24 V DC feed but no galvanic isolation between the communication ports for RS232, RS422/485 and USB. Only the Ethernet connection has galvanic isolation.

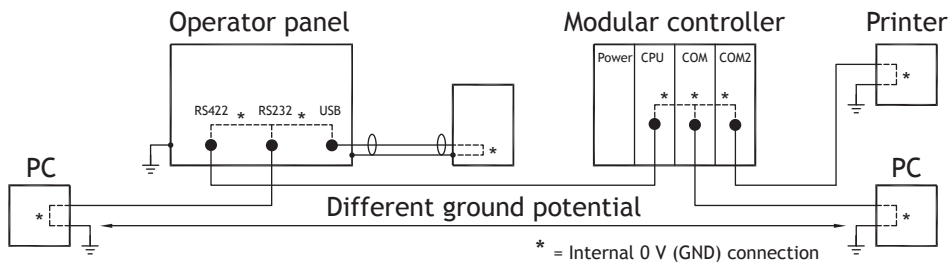

When a PC is connected to the operator panel, the panel's internal 0 V (GND) will be connected to the protective ground via the PC.

A number of USB devices can have the shield connected together with the protective ground. Here, the operator panel's 0 V (GND) is connected to the protective ground when, for example, a USB memory stick, keyboard or similar device is plugged in.

If a number of units are connected that have a 0 V and a ground connection, and these are connected to various grounding points, there is a substantial risk of problems. Grounding currents go through communication cables, the rear plate of the controller, and internally in the operator panel, and can cause errors.

Use external units to improve communication and achieve galvanic isolation. Westermo has good industry-standard insulators that are also insulated from the 24 V DC feed.

Note:

It is very important to make sure that the 24 V feed in the external insulation unit is not connected to one of the communication outlets. If it does not have 100% insulation against the 24 V feed, disturbances and grounding currents from the 0 V on the 24 V side will disrupt communication.

Using this type of unit solves one problem but creates a larger problem! A substandard installation may work now, but problems may arise when other devices are connected.

7.7 Cable and Bus Termination RS485

- If maximum transfer distance and maximum transfer speed is needed, shielded and twisted pair cable should be used. The mutual capacitance may not exceed 52.5 pF/m, and the cable area should be at least 0.25 mm² (AWG 24).
- 0 V, the reference voltage for communication should be included in the cabling. With two-way communication use two pairs; one pair for communication and one pair for 0 V.
- The shield must be grounded at one end. The other end is usually grounded, but with longer distances or when there is a difference in the ground potential, the shield should be connected to the ground via 0.1 µF/250 V plastic capacitor to prevent ground current in the braided shield. A number of manufacturers recommend that the shield be grounded at each node. Various manufacturers have different systems for bus termination.

Depending on the recipients' design, the bus wires may be on the same level or require pull-up or pull-down to ensure that no faulty signals are detected when the bus is in resting mode (all transmitters are disconnected).

8 APPENDIX

This appendix provides information for accessing the HMI service menu and interfacing an AKI to an AKD PDMM and Programmable Automation Controller (Panel PAC).

8.1 HMI Service Menu

The HMI provides a service setting menu to perform touch calibration, IP settings, self-tests, and other options. After a project is loaded onto a panel, the service menu is accessible by following the procedures described below.

1. Apply power to the panel.
2. When the hourglass displays, press a finger on the screen and hold for approximately 20 seconds.
3. Enter a PIN code if the service menu is password protected.
4. The touch calibration screen displays the following message:
“Tap anywhere on screen or touch calibrate will start in 10 seconds.”
5. Press finger on screen again to enter the service menu.

The Service Menu displays:



Note: Additional information about the Service Menu options are available in the Kollmorgen Visualization Builder (KVB) online help: HMI Panel System Software/Service Menu

8.2 HMI to PDMM Connection and Programming

Modbus TCP is used to communicate from the Ethernet port of an AKI panel to the X32 connector on the top of an AKD PDMM, also referred to as an Ethernet service port. If the AKD PDMM is connected to a network, switch, or hub you can have Modbus communication active at the same time as you are programming the AKD PDMM with your computer through KAS Integrated Development Environment software (KAS IDE). This is also appropriate for TCP, HTTP, Profinet, or Ethernet IP communication that also uses the X32 port and any combination can be active simultaneously.

When using HMI panels the Modbus addresses are setup automatically through linking of the KAS IDE development software with the KVB development software. This is controlled in the KAS IDE dictionary using the KVB column and checkboxes that can be selected to share that variable (global or local) over Modbus. Each time the project is compiled this list is updated. If both software packages are installed on your computer, use the KAS IDE by right-clicking on the System option in the Project Explorer and select "Add HMI Device" to display a list of HMI panels that Kollmorgen has available. Double-click on the project to launch KVB and automatically import tags and the target IP address for the KAS controller.

8.3 HMI to PAC Connection

The same Ethernet service port of the AKI panel can be used to connect and interface with a PAC. Using a standard Ethernet cable, connect the HMI to your network, switch, or hub. Communication is achieved by using Ethernet TCP/IP and the target IP address for the PAC is automatically linked in the KVB software as described in the HMI to PDMM Connection and Programming section of this document.

About KOLLMORGEN

Kollmorgen is a leading provider of motion systems and components for machine builders. Through worldclass knowledge in motion, industry-leading quality and deep expertise in linking and integrating standard and custom products, Kollmorgen delivers breakthrough solutions that are unmatched in performance, reliability and ease-of-use, giving machine builders an irrefutable marketplace advantage.

For assistance with your application needs, visit www.kollmorgen.com or contact us at:

North America KOLLMORGEN

203A West Rock Road
Radford, VA 24141 USA

Web: www.kollmorgen.com

Mail: support@kollmorgen.com

Tel.: +1 - 540 - 633 - 3545

Fax: +1 - 540 - 639 - 4162

Europe KOLLMORGEN Europe GmbH

Pempelfurtstraße 1
40880 Ratingen, Germany

Web: www.kollmorgen.com

Mail: technik@kollmorgen.com

Tel.: +49 - 2102 - 9394 - 0

Fax: +49 - 2102 - 9394 - 3155

Asia KOLLMORGEN

Rm 2205, Scitech Tower, China
22 Jianguomen Wai Street

Web: www.kollmorgen.com

Mail: sales.asia@kollmorgen.com

Tel.: +86 - 400 666 1802

Fax: +86 - 10 6515 0263