

Systems
Technical
Publication

SERVOSTAR® 600

with Kollmorgen GOLDLINE® Xt



KOLLMORGEN



Kollmorgen SERVOSTAR® 600 Amplifier

- **230 Volt Three Phase AC Input Power**
- **Resolver Feedback**
- **Integrated Power Supply**
- **Fully Digital Control**
- **CE, UL, cUL**
- **Motor Brake Control**

The SERVOSTAR 600 amplifier is a compact, fully digital drive-amplifier designed to simplify installation, system set-up, and system reliability.

FEATURES:

Servo Control

- Easy to tune servo loops
- Advanced sinewave commutation technology provides smooth, precise low-speed control and high speed performance
- Velocity loop bandwidths to 400 Hz
- DQ Current control increases high speed peak torque performance for faster cycle rates
- Space Vector Modulation reduces normal power stage switching losses
- Torque angle control enhances motor performance
- Fully digital control loops
- Compact and attractive rugged metal package for space-saving, modern appearance - metal package minimizes electrical noise emission & susceptibility
- Command modes: Torque, Velocity, Position, Electronic Gearing Pulse Following, and Motion Task
- Five current ratings: 3, 6, 10, 14, and 20 amp RMS/phase continuous
- 2 to 1 peak/continuous current rating (5 second at peak)
- Run time counter

Easy Connectivity

- Built in encoder equivalent output can eliminate the need for an additional position feedback device
- RS-232 Communication

- Unique multi-drop configuration allows a PC or PLC to communicate to multiple SERVOSTAR 600 amplifiers via single RS-232 connection
- SERVOSTAR 600's versatile communication capabilities make it easy to integrate machine control data directly from the factory floor to your information system
- Analog $\pm 10V$, pulse/direction, master encoder, and serial port, I/O command options

Robust Design

- ESD rugged circuit design and fully metallic enclosure
- Full protection against short circuit, overvoltage, undervoltage, heatsink overtemperature, motor overtemperature, overspeed, overcurrent, and feedback loss
- UL, cUL listed, and CE
- Built-in line filter for CE
- Flash memory

Windows Start-up Environment

- Graphical environment simplifies set up
- PC "Oscilloscope" for measuring real-time motion performance
- Interactive MOTIONTASK Programming

Configurable I/O

- 2 separate analog inputs (14 and 12 bit resolution) configurable to 6 different command modes
- 2 analog outputs
- 4 digital inputs
- 2 digital outputs
- I/O can be configured to a variety of functions to customize the SERVOSTAR 600 to individual machines

I/O Option Card (see page 5)

- Adds 14 additional digital inputs and 8 digital outputs
- All I/O are optically isolated
- Simple plug in to top face of Amplifier

Regenerative Power Sharing

- Patented circuitry allows the DC bus from two or more amplifiers to be connected together allowing regen power to be shared among multiple drives

Built in Parameter Unit

- Perform basic drive set up without the need for a PC
- Provides diagnostic information
- Allows motor selection from parameters store in memory

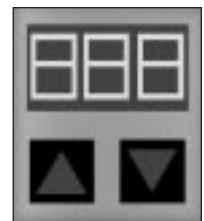

Built in Safety Relay

- Switches off the power stage to ensure personnel safety and prevents an unintended restart of the drive, even in the event of a fault
- Allows DC bus to remain on

Motion Capabilities

The SERVOSTAR 600 can be configured to perform motion control that normally requires a fully programmable drive with a motion language. With the SERVOSTAR 600 there is no programming language to learn; the user only “fill in the blanks” to create common motion tasks

- Up to 180 motion task can be stored in permanent memory
- Motion Tasked can be linked together.
- 10 types of homing
- Speed profile/registration control
- Adjustable S curve acceleration

- Absolute and relative (index) moves
- Linking of motion task (sequencing)
- Adjustable Following-Error window
- Adjustable window for the In Position signal

Linked motion tasks are started:

- Immediately upon reaching a targeted position
- Digital Input upon reaching the targeted position
- A Preset Time Delay after the targeted position is reached

Motion Examples

INCREMENTAL MOVE

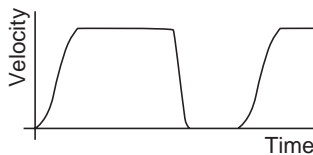

ABSOLUTE MOVE

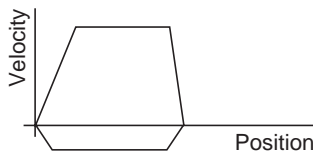

ELECTRONIC GEARING 5:1 (MASTER/SLAVE)

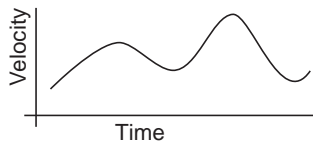

MACRO MOVE

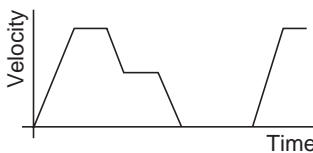

Application Examples

- material handling
- bottle making
- packaging
- soft positioning
- robot
- conveyor belt controlling
- fast positioning
- special cleaning process
- part selection
- glass processing
- robot
- wirepuller
- textile industry
- printing
- electronics
- web converting
- cut to length

SERVOSTAR 600

CONNECTOR INFORMATION

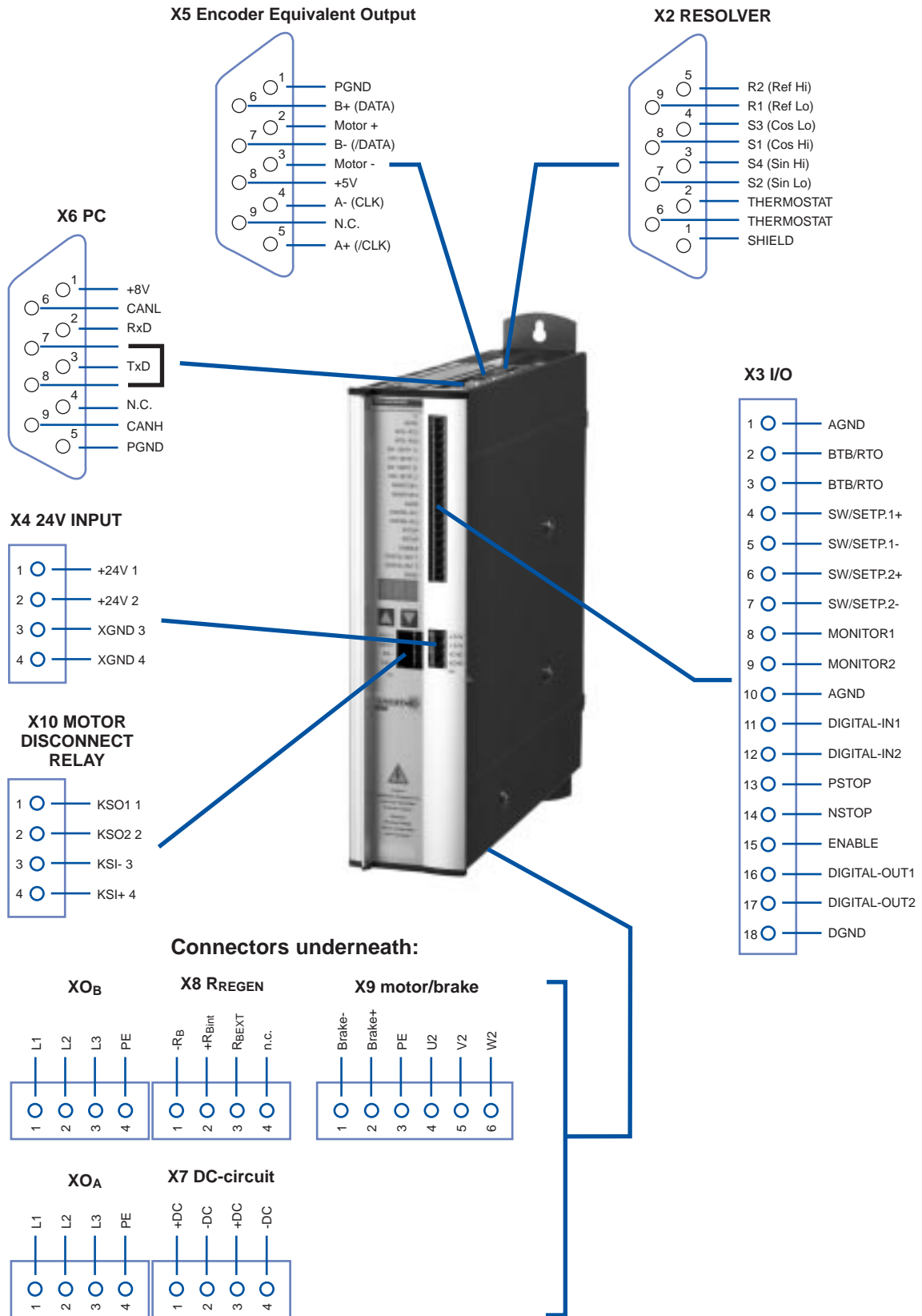

I/O OPTION CARD

CONNECTOR POSITION

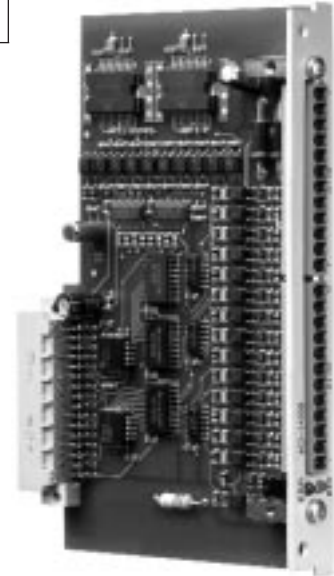
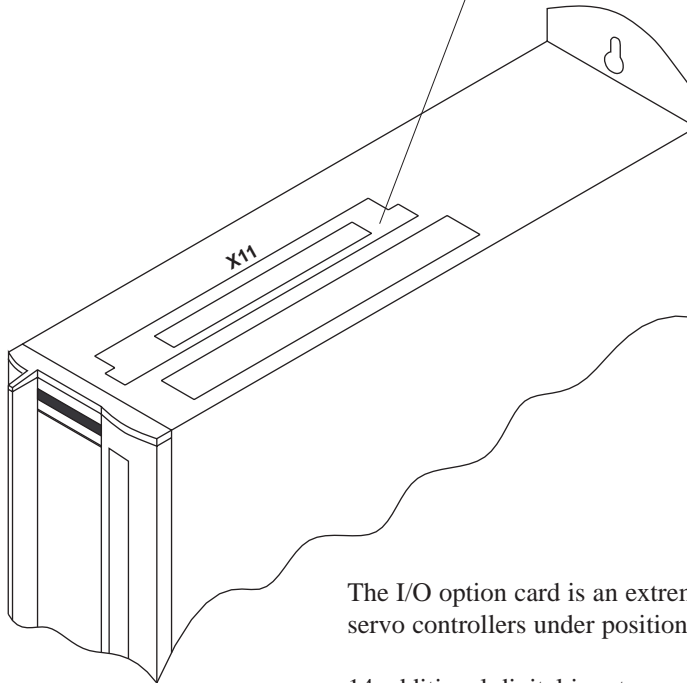

The I/O option card is an extremely economical way of operating servo controllers under position control for simple automation tasks.

14 additional digital inputs permit the selection and start of the motion tasks that are stored in the motion-task memory of the SERVOSTAR® 600. All the important functions for the position controller that is integrated into the servo controller can thus be operated from a small, independent control system.

8 digital outputs report the status of the drive to the higher-level control.

CONNECTOR ASSIGNMENTS

Connector X11A			Connector X11B		
Terminal	Fn.	Description	Terminal	Fn.	Description
1	In	A0	1	In	MT_Restart
2	In	A1	2	In	Start_MT
3	In	A2	3	Out	InPos
4	In	A3	4	Out	Next-InPos
5	In	A4	5	Out	Sfault
6	In	A5	6	Out	PosReg1
7	In	A6	7	Out	PosReg2
8	In	A7	8	Out	PosReg3
9	In	Reference	9	Out	PosReg4
10	In	Sfault_clear	10	Out	Reserve
11	In	Start_MT Next	11	Sup.	24V DC
12	In	Start_Jog v=x	12	Sup.	I/O-GND

Electrical characteristics

- Closed loop velocity bandwidth up to 400 Hz
- Motor current ripple frequency 16 kHz
- Switching frequency: 8 kHz
- Long term speed regulation (0.01%)
- Position loop update rate 250 μ s (4 kHz)
- Velocity loop update rate 250 μ s (4 kHz)
- Commutation update rate 62.5 μ s (16 kHz)
- SVM Current loop update rate 62.5 μ s (16 kHz)

Fault protection

- Output phase to phase and phase to ground short circuit protection
- Overvoltage
- Undervoltage
- Overtemperature (motor and amplifier)
- Overspeed
- Overcurrent
- Feedback loss
- Foldback
- Supply loss
- Excessive position error

Environmental

- Operation range
 - Ambient 0 to 45°C (derated above ambient up to 55°C)
 - Storage -25°C to 55°C
- Humidity (non-condensing) max 85%

Velocity Loop Compensation

- PI Plus controller (PDFF Format) or PI controller
- Field tunable and digital repeatability

Position Loop Compensation

- Proportional loop with Feed Forward

Analog I/O

- 2 Configurable Inputs: \pm 10V, 12 and 14 bit resolution
- 2 Configurable Outputs: \pm 10V, 10 bit resolution

Digital I/O

- 4 Configurable Inputs: 24 volts, PLC-compatible
- 2 Configurable Outputs: 24 volts (open collector), PLC-compatible
- Remote enable Input: 24V, PLC-compatible

Drive Status Relay (BTB/RTO)

- Contact closure rated for 0.5 amps, 24 Volt

Pulse or Master/Slave Input

- Pulse command: pulse/direction or quadrature encoder format
- RS-485 receivers
- Up to 16 slave amplifiers can be connected together
- Input ratio is configurable

Position Feedback For User (Encoder Equivalent Output Port)

- Configurable to Encoder Equivalent (ROD) or SSI format
- Encoder Equivalent (ROD): A Quad B with Marker (zero) pulse, RS-485 driver
- SSI (serial synchronous interface): max clock frequency is 1.5 Mhz, RS-485 driver
- Programmable resolution

I/O Extension Card (Option)

- Field Installable
- 14 Digital Inputs 24V, PLC-compatible
- 8 Digital Outputs 24V, PLC-compatible
- 24V PLC Interface

Communications

- RS-232 Interface

Operational modes

- Torque control — from analog or digital command
- Velocity control — from analog or digital command
- Pulse following
- Gearing from quad encoder input
- Motion Task
- Serial Commands

Diagnostics

- 3 digit Seven segment LED display
- Error history log
- Internal variable monitoring
- PC scope

Motor Feedback

- Resolver

AMPLIFIER SPECIFICATIONS

Power Regeneration Options

- Internal
- External - using BAR housed resistors
- Bus Sharing - Distributes regen power among multiple amplifiers

Built in Parameter Unit

- Displays drive status information
- Parameters: Drive Address, baud rate, Velocity loop tuning, Motor type, Position output information format, brake, regen type

Motor Brake Control

- 24V optional holding brake in the motor can be controlled directly by the SERVOSTAR 600

Power Inputs

- 230 VAC 3phase, 50 or 60 Hz, built in line filter for CE requirements
- 24 VDC @ 1 amp (3 amps with brake) For Logic

Amplifier Ratings

Model	Output Continuous Current Per Phase (RMS/phase)	Output Peak Current Per Phase (5 sec)	Internal Power Dissipation (Watts)	AC Input Line Voltage (3 phase)	Rated Input Power (KVA) @230 V	Continuous Internal Regen Power (Watts)	Continuous External Regen Power (Watts)
S603	3	6	40	230	1.4	80	500
S606	6	12	60	230	2.8	200	1,500
S610	10	20	90	230	4.6	200	1,500
S614	14	28	160	230	6.5	200	1,500
S620	20	40	200	230	9.3	200	1,500

SERVOSTAR 600

REGENERATION SIZING / DIMENSIONS

Resistive Regeneration Sizing

Shunt regeneration is required to dissipate energy that is pumped back into the DC bus during load deceleration. The amount of shunt regeneration required is a function of the sum of simultaneously decelerating loads. The loads need to be defined in terms of system inertia, maximum speed, and deceleration time. In addition, the duty cycle must be known. Contact Kollmorgen Customer Support Network for application assistance at 1-800-77 SERVO or servo@kollmorgen.com.

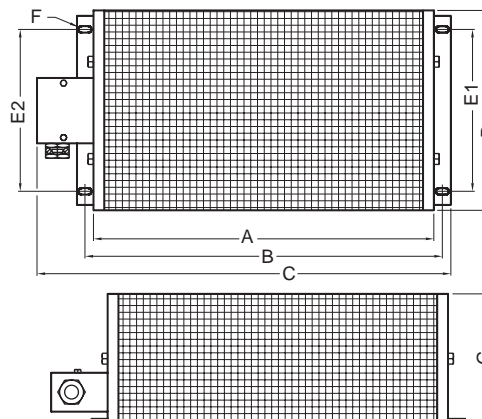
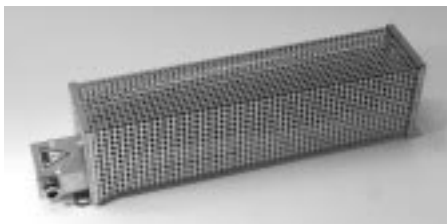

Model	Watts	Ohms	Amplifiers	A	B	C	D	E1	E2	F	G
BAR-250	250	33	S603, S606,	330(12.99)	390(15.35)	412(16.22)	66(2.60)	44(1.73)	35(1.38)	4,5x9(.20x.35)	77(3.03)
BAR-500	500	33	S610, S614, S620	400(15.75)	426(16.77)	486(19.13)	92(3.62)	64(2.52)	64(2.52)	6,5x9(.20x.35)	120(4.72)
BAR-1500	1500	33	S606, S610, S614, S620	500(19.69)	526(20.71)	586(23.07)	185(7.28)	150(5.91)	150(5.91)	6,5x9(.20x.35)	120(4.72)

SERVOSTAR 600 DIMENSIONS

S603/06/10/14/20

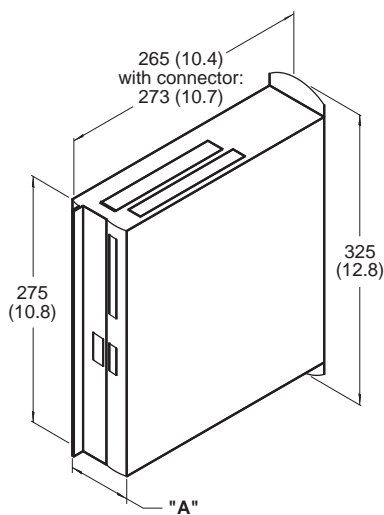

Dimensions in mm (inches)

Model	Size	Dim. "A"
S603	3 AMP	70 (2.8)
S606	6 AMP	70 (2.8)
S610	10 AMP	70 (2.8)
S614	14 AMP	100 (3.9)
S620	20 AMP	120 (4.7)

ADDITIONAL FUNCTIONS

MOTIONLINK® for Windows takes the fear out of setting up a servo system. Designed for the novice as well as the advanced user, **MOTIONLINK** lets users quickly set-up and fine tune system performance.

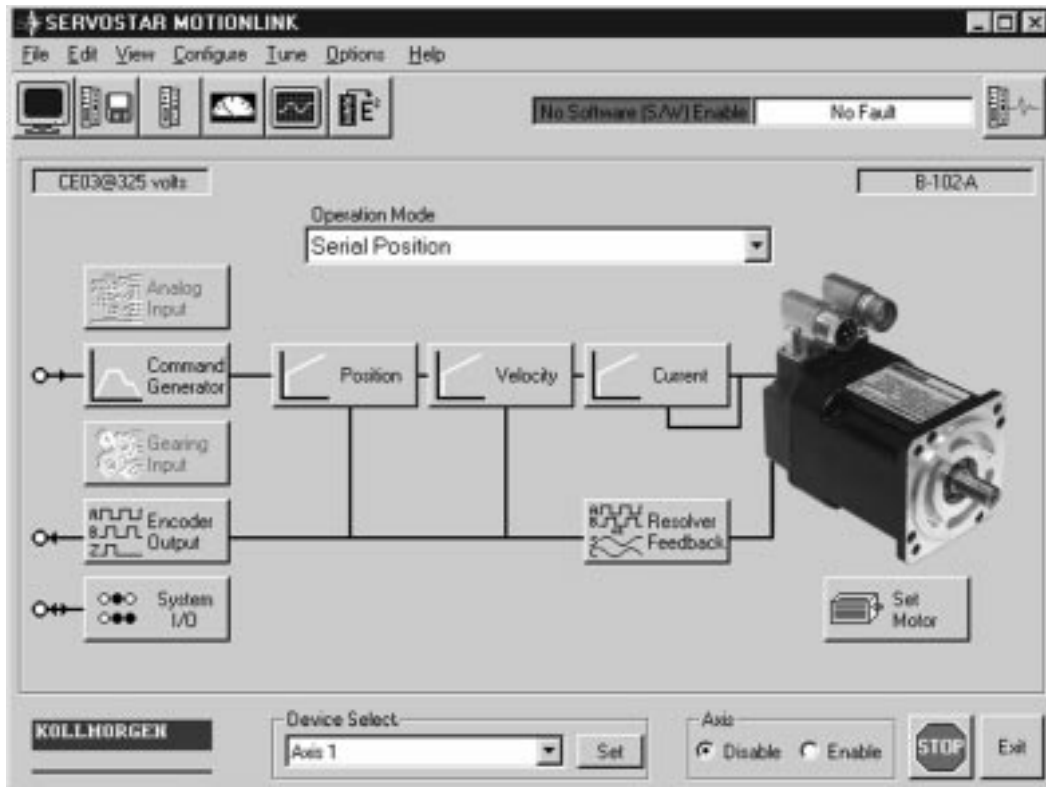

PC Oscilloscope:

For closely evaluating system performance **MOTIONLINK** includes the functionality of an oscilloscope. You can very easily excite the load then review performance graphically on your computer screen.

Direct Terminal Mode:

This mode turns your computer into a "dumb terminal." Variables or parameters can be monitored and changed using the **SERVOSTAR 600's** command language. This mode is ideal for advanced users who want to get directly in the "heart" of the **SERVOSTAR 600**.



Tuning:

Velocity and position loop tuning is straight forward, allowing the novice user to achieve the best machine performance.

Monitor Mode:

Allows you to monitor key operation variables. Speed, torque, and other variables can be viewed in real PSEUDO time in linear gauge format.



Auto Set-up:

MOTIONLINK auto set-up environment walks even the first time user through line voltage, motor, operation mode and load tuning to make system configuration friendly and fast.

Configuring I/O:

Inputs & Outputs are configurable to a wide variety of functions to configure the **SERVOSTAR 600** to individual machine needs.



MOTIONLINK has many other features including:

- Saving drive configuration to disk
- Activating position limits
- Displaying amplifier status
- Setting acceleration amps
- Limiting max speed or torque

CONFIGURABLE AND READABLE FUNCTIONS

Basic Set Up <ul style="list-style-type: none"> • Input Power • Main Phase Missing • Max Regen Power • Internal or External Regen Resistor • Drive Name and Serial No * • Run Time * • Firmware Version * • Hardware Version * 	Velocity Control <ul style="list-style-type: none"> • Speed Command Scaling • Speed Command Ramp (Accel) • Speed Command Ramp (Decel) • Maximum Speed • Proportional Gain • Integral Time Constant • Feedback Filter • Motion direction 	Motion Homing/Jogging <ul style="list-style-type: none"> • Direction • Homing Type • Reference Offset • Start Command • Jog Command • Homing Velocity • Jog Velocity
Drive Operation Modes <ul style="list-style-type: none"> • Digital Speed • Analog Speed • Digital Torque • Analog Torque • Electronic Gearing • External Position Control • Internal Position - MotionTasks 	Current Control <ul style="list-style-type: none"> • Current Command Scaling • Current Foldback • Cont Drive Current • Peak Drive Current • Proportional Gain • Integral Time Constant 	Communications <ul style="list-style-type: none"> • RS-232 from PC • Drive Address • Message Types from Drive • Prompt Configuration • Scan
Digital Scope Tool <ul style="list-style-type: none"> • Record real time data • Display on PC Oscilloscope • Start Current Move • Start Jog Move • Start Position Move • Record Start • Adjust Trigger • Recording in Process * • Cancel Recording • Recording Done * • Transmit Data to PC Oscilloscope 	Motor Configuration <ul style="list-style-type: none"> • Motor Name and Number * • Motor Continuous Current • Motor Peak Current • Motor Inductance • Motor Poles • Motor Max Speed • Motor Brake (with or without) • Motor Adaptive Gain • Motor Speed Angle Advance • Motor Torque Angle Advance 	Position Output (Motor) <ul style="list-style-type: none"> • Format: Off, Encoder equivalent output or SSI format Encoder Equivalent Output <ul style="list-style-type: none"> • Resolution of Encoder Equiv Output • Marker Pulse Offset SSI <ul style="list-style-type: none"> • Baud rate of SSI Output • Format type (binary or gray code) • Standard or Inverted Clock • Input Edge Positive or Negative
Feedback Configuration <p>Resolvers:</p> <ul style="list-style-type: none"> • Number of Poles • Resolver-zero offsetting • Resolver Bandwidth • Feedback Gain 	Drive Status <ul style="list-style-type: none"> • Actual Error * • Actual Warning * • Last 10 Errors * • Rate of Occurrence * • Drive Reset Command 	Position Control <ul style="list-style-type: none"> • Proportional Gain • Integral Action Time • Feed Forward • Following Error *
Drive Monitoring <ul style="list-style-type: none"> • Regen Wattage * • Actual Position (within one rev) * • Actual Position * • Actual Speed * • Command Speed * • Current Foldback Level * • Drive Temperature * • Heatsink Temperature * • Effective Current * • D Current Component * • Q Current Component * • Analog Commands * • DC Bus voltage * 	Others <ul style="list-style-type: none"> • Stop Drive • Drive Enable • Drive Disable 	Motion-Gear Mode <ul style="list-style-type: none"> • GearMode Type: • Encoder Follower • Pulse Follower

* READ ONLY

CONFIGURABLE AND READABLE FUNCTIONS

Motion Task (or Blocks)

- Change/Copy Motion Task
- Position Type (Rotary or Linear)
- Master/Slave
- Motion Task Stop
- In Position
- Set Position Registers
- Motion Task Start
- Acceleration ramp
- Deceleration Ramp
- Min Acceleration
- Max Velocity
- Position Capture (Positive or Negative Edge)

Analog Input

- Two Differential Analog Inputs that can be configured in the following ways:

Mode 0

The amplifier uses Input 1 only, depending on the operation mode.

OPMODE	Input 1	Input 2
analog speed	speed command	inactive
analog torque	torque command	inactive

Mode 1

The amplifier uses Input 1 or 2, depending on the operation mode.

OPMODE	Input 1	Input 2
analog speed	speed command	inactive
analog torque	inactive	torque command

Mode 2

Both inputs are switched off.

OPMODE	Input 1	Input 2
analog speed	inactive	inactive
analog torque	inactive	inactive

Mode 3

The amplifier uses Input 1, depending on the operation mode. Input 2 is used for limiting peak current.

OPMODE	Input 1	Input 2
analog speed	speed command	limits peak torque
analog torque	torque command	limits peak torque

Mode 4

The amplifier uses the sum of Inputs 1 and 2, depending on the setting of OPMODE.

OPMODE	Input 1 + Input 2
analog speed	speed setpoint
analog torque	torque setpoint

Mode 5

The amplifier uses the product of Inputs 1 and 2, depending on the setting of OPMODE. The voltage on Input 2 has the effect of a weighting factor for Input 1.

OPMODE	Input 1 • Input 2
analog speed	speed setpoint
analog torque	torque setpoint

- Signal dead band
- Signal offset
- Auto Offset command
- Input Configuration

Analog Output

- Two Analog Outputs can be configured for Actual Speed, Actual Current, Commanded Speed, Commanded Current, or Contouring error window

Digital I/O

Inputs:

The 4 digital inputs can be configured as follows:

IN1MODE=1	External drive reset (only available at Input 1)
IN3MODE=2	Activates PSTOP in positive direction of travel (only available at Input 3)
IN4MODE=3	Activates NSTOP in negative direction of travel(only available at Input 4)
IN3MODE=4	Activates PSTOP function combined with integral gain off (only available at Input 3)
IN4MODE=5	Activates NSTOP function combined with integral gain off (only available at Input 4)
IN3MODE=6	Activates both PSTOP and NSTOP (only available at Input 3)
IN3MODE=7	Activates both PSTOP and NSTOP with integral gain off (only available at Input 3)
INxMODE=8	Switch between analog input 1 and analog input 2
INxMODE=9	Select a motion task that is stored in memory
INxMODE=10	Turn integral gain off in the velocity loop
INxMODE=11	Switch between velocity and torque control
INxMODE=12	Home switch
INxMODE=13	Change over position feedback from encoder equivalent output format (ROD) to SSI format
INxMODE=14	Reset following error or limit infringement warning
INxMODE=15	Start next motion task once the targeted position is reached
INxMODE=16	Start a motion task. Enter task number through an auxiliary variable
INxMODE=17	Start motion task that is bit coded on the digital inputs
INxMODE=18	Switch over to second (lower) peak value of current
INxMODE=19	Reserved
INxMODE=20	Start jog. Enter speed through an auxiliary variable
INxMODE=21	Turn off undervoltage monitoring
INxMODE=22	Restart motion task that was interrupted
INxMODE=23	Same as INxMode 16 except motion task started on rising edge only
INxMODE=24	Switch between Opmodes a (Input high) and b (Input low) when $INxTRIG = a*256+b$
INxMODE=25	During set up, set encoder equivalent output marker pulse offset
IN2MODE=26	Position latch on rising edge of input (only available at Input 2)
INxMODE=30	On rising edge of input the string stored in INHCMD will be processed. On falling edge of input the string stored in INLCMD will be processed. Multiple commands in the string are possible up to total of 64 characters.

Outputs:

The 2 digital outputs can be configured as follows:

OxMODE=1	Motor speed is less than preset value	OxMODE=16	Target position reached for each task in an automatically executed sequence of motion task (Next-In Position)
OxMODE=2	Motor seed is greater than preset value	OxMODE=17	Error or warning message is signaled
OxMODE=3	Drive power stage ready	OxMODE=18	Error message is signaled
OxMODE=4	Preset regen power is exceeded	OxMODE=19	DC bus voltage is higher than an auxiliary value
OxMODE=5	Software travel limit is reached	OxMODE=20	DC bus voltage is lower than an auxiliary value
OxMODE=6	Actual position is greater than preset value	OxMODE=21	Drive is enabled
OxMODE=7	Target position reached (In Position)	OxMODE=22	Marker pulse (low speeds only)
OxMODE=8	Actual current feedback less than preset value	OxMODE=23	Option card status
OxMODE=9	Actual current feedback greater than preset value	OxMODE=24	Homing complete
OxMODE=10	Following error exceeded	OxMODE=28	Preset function of position register 0 is reached
OxMODE=11	I ² T monitoring threshold is reached	OxMODE=29	Preset function of position register 5 is reached
OxMODE=12	Preset function of position register 1 is reached	OxMODE=35	Status of hardware and software enable
OxMODE=13	Preset function of position register 2 is reached		
OxMODE=14	Preset function of position register 3 is reached		
OxMODE=15	Preset function of position register 4 is reached		

INTRODUCTION

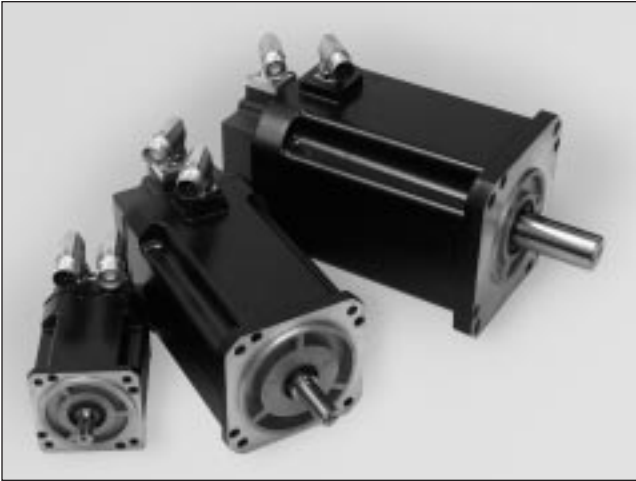

Kollmorgen GOLDLINE® XT Series Servomotors

- 1.29 to 48.0 N-m (0.95 to 35.4 lb-ft) Continuous System Torque
- Up to 87 N-m (64 lb-ft) System Peak Torque
- 90mm (3.5 in), 130mm (5.1 in), and 174mm (6.8 in) Square Frames
- Resolver Feedback
- Speeds up to 6000 RPM

Kollmorgen **GOLDLINE XT 30**, **XT 50**, and **XT 70** series servomotors provide high performance, cost-effective solutions in compact, rugged packages suitable for heavy industrial environments.

Kollmorgen's unique magnetic design provides extremely low cogging and torque ripple for smooth operation, while allowing high torque-to-inertia for rapid acceleration. Medium inertia rotors for better load matching are also available for some models.

The proprietary stator assembly provides more efficient heat transfer for high torque density (compact size), and at the same time increases thermal time constants to allow longer overloads on machines.

The **GOLDLINE XT** series base models designed for use with the **SERVOSTAR® 600** amplifiers come equipped with a rugged, single speed resolver, and CE compliant, rotateable right angle connectors. Optional 24 Vdc brakes (controlled directly by the drive) are also available.

FEATURES:

- Multiple stack lengths
- Short overall motor lengths
- Optimized torque-to-inertia ratios
- Low cogging & torque ripple
- Speeds to 6000 RPM standard
- Increased thermal time constant
- English and Metric standard mounting
- UL recognized, CE compliant
- Optimized windings to match **SERVOSTAR® 600**
- Rotatable connectors
- Rugged resolver feedback
- Built-in thermostat
- IP65 sealing

OPTIONS:

- IP67 sealing
- Integral electrically-released brake (24 VDC)
- Mating connectors (CE compliant)
- Tapered shaft (**XT50 & XT70**)
- Maximum inertia rotor (**XT50 & XT70**)

Kollmorgen GOLDLINE XT and SERVOSTAR 600

SYSTEM PERFORMANCE CURVES

1 n Motor MT302A n Amplifier: S603

Performance Specification	Symbol	Units	Value
Cont. Torque at stall	Tc	lb-ft	0.95
		N-m	1.29
Peak Torque at stall	Tp	lb-ft	1.75
		N-m	2.37
Cont. Power	HP rated	HP	0.79
	kW rated	kWatts	0.59
Rated Speed	Nr	RPM	4500
Max. Speed	Nmax	RPM	4500
Motor Inertia	Jm	lb-ft-s ²	0.0000343
		kg-m ²	0.0000465
Motor Weight	Wt	lb	5.6
		kg	2.5

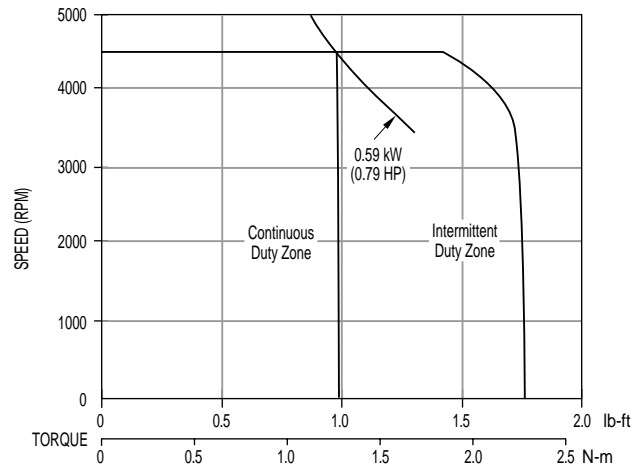

2 n Motor MT304A n Amplifier: S603

Performance Specification	Symbol	Units	Value
Cont. Torque at stall	Tc	lb-ft	1.86
		N-m	2.52
Peak Torque at stall	Tp	lb-ft	3.62
		N-m	4.91
Cont. Power	HP rated	HP	0.95
	kW rated	kWatts	0.71
Rated Speed	Nr	RPM	3000
Max. Speed	Nmax	RPM	3000
Motor Inertia	Jm	lb-ft-s ²	0.0000596
		kg-m ²	0.0000808
Motor Weight	Wt	lb	7.3
		kg	3.3

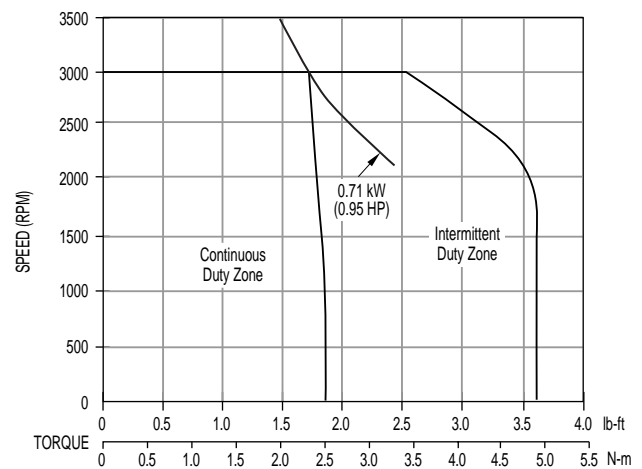

3 n Motor MT304B n Amplifier: S606

Performance Specification	Symbol	Units	Value
Cont. Torque at stall	Tc	lb-ft	1.81
		N-m	2.45
Peak Torque at stall	Tp	lb-ft	3.78
		N-m	5.13
Cont. Power	HP rated	HP	1.8
	kW rated	kWatts	1.3
Rated Speed	Nr	RPM	6000
Max. Speed	Nmax	RPM	6000
Motor Inertia	Jm	lb-ft-s ²	0.0000596
		kg-m ²	0.0000808
Motor Weight	Wt	lb	7.3
		kg	3.3

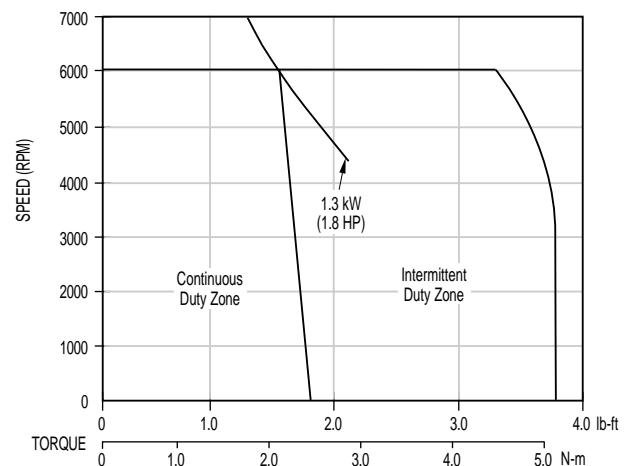

Notes:

1. Continuous duty operation is with motor mounted to 8" x 12" x 3/8" aluminum faceplate in 40° C ambient.
2. All curves shown at 60 Hz input, derate max. speed and peak power by 15% for 50 Hz operation. (for models with shaft seals, derate by 0.059 lb-ft)
3. All curves represent typical performance. Always allow appropriate safety factor when sizing systems.

Kollmorgen GOLDLINE XT and SERVOSTAR 600

SYSTEM PERFORMANCE CURVES

4 n Motor MT306A n Amplifier: S603

Performance Specification	Symbol	Units	Value
Cont. Torque at stall	Tc	lb-ft	2.49
		N-m	3.38
Peak Torque at stall	Tp	lb-ft	4.93
		N-m	6.69
Cont. Power	HP rated	HP	1.1
	kW rated	kWatts	0.82
Rated Speed	Nr	RPM	2500
Max. Speed	Nmax	RPM	2500
Motor Inertia	Jm	lb-ft-s ²	0.0000819
		kg-m ²	0.000111
Motor Weight	Wt	lb	8.4
		kg	3.8

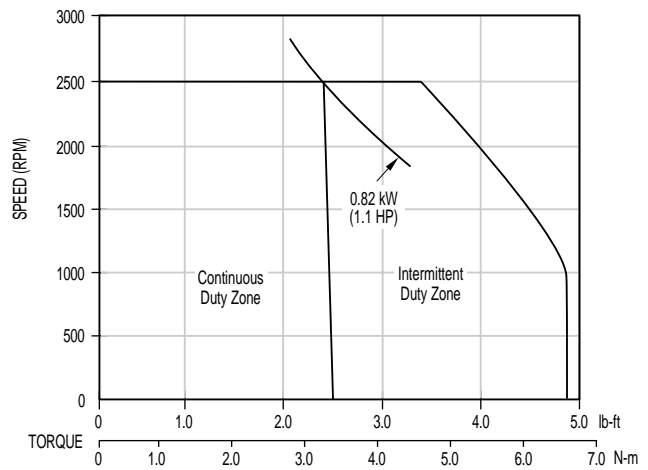

5 n Motor MT306B n Amplifier: S606

Performance Specification	Symbol	Units	Value
Cont. Torque at stall	Tc	lb-ft	2.45
		N-m	3.32
Peak Torque at stall	Tp	lb-ft	4.96
		N-m	6.73
Cont. Power	HP rated	HP	2.0
	kW rated	kWatts	1.5
Rated Speed	Nr	RPM	4600
Max. Speed	Nmax	RPM	4600
Motor Inertia	Jm	lb-ft-s ²	0.0000819
		kg-m ²	0.000111
Motor Weight	Wt	lb	8.4
		kg	3.8

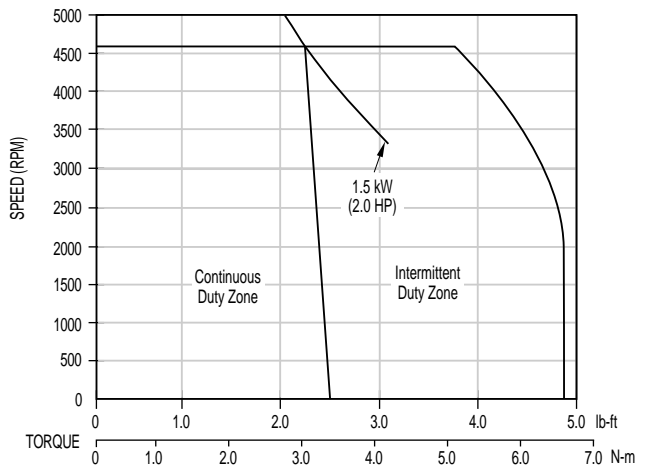

6 n Motor MT308B n Amplifier: S606

Performance Specification	Symbol	Units	Value
Cont. Torque at stall	Tc	lb-ft	3.53
		N-m	4.79
Peak Torque at stall	Tp	lb-ft	7.21
		N-m	9.77
Cont. Power	HP rated	HP	1.7
	kW rated	kWatts	1.3
Rated Speed	Nr	RPM	3000
Max. Speed	Nmax	RPM	3000
Motor Inertia	Jm	lb-ft-s ²	0.000129
		kg-m ²	0.000175
Motor Weight	Wt	lb	11.3
		kg	5.1

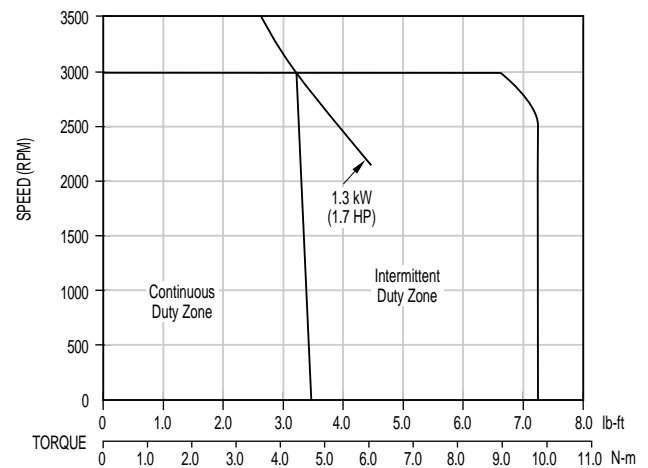

Notes:

1. Continuous duty operation is with motor mounted to 8" x 12" x 3/8" aluminum faceplate in 40° C ambient.
2. All curves shown at 60 Hz input, derate max. speed and peak power by 15% for 50 Hz operation. (for models with shaft seals, derate by 0.059 lb-ft)
3. All curves represent typical performance. Always allow appropriate safety factor when sizing systems.

Kollmorgen GOLDLINE XT and SERVOSTAR 600

SYSTEM PERFORMANCE CURVES

7 n Motor MT502A n Amplifier: S603

Performance Specification	Symbol	Units	Value	
Cont. Torque at stall	Tc	lb-ft	2.43	
		N-m	3.30	
Peak Torque at stall	Tp	lb-ft	4.58	
		N-m	6.21	
Cont. Power	HP rated	HP	1.1	
	kW rated	kWatts	0.80	
Rated Speed	Nr	RPM	2400	
Max. Speed	Nmax	RPM	2400	
Motor Inertia	Jm		min J	max J
		lb-ft-s ²	0.00037	0.00079
		kg-m ²	0.00051	0.00108
Motor Weight	Wt	lb	12.9	
			14.8	
		kg	5.9	

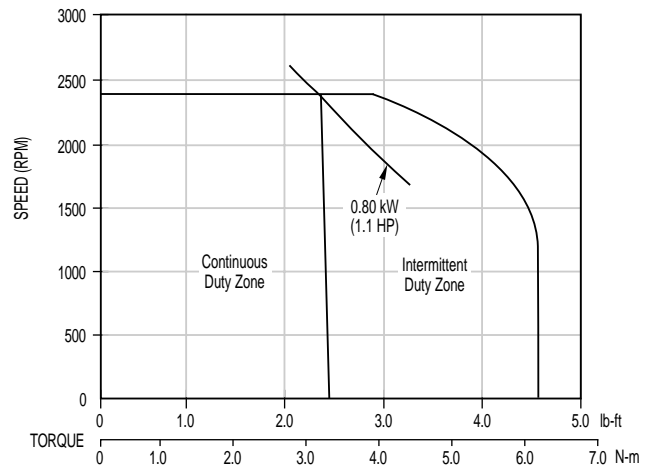

8 n Motor MT502B n Amplifier: S606

Performance Specification	Symbol	Units	Value	
Cont. Torque at stall	Tc	lb-ft	2.43	
		N-m	3.30	
Peak Torque at stall	Tp	lb-ft	4.99	
		N-m	6.76	
Cont. Power	HP rated	HP	1.6	
	kW rated	kWatts	1.2	
Rated Speed	Nr	RPM	4000	
Max. Speed	Nmax	RPM	4000	
Motor Inertia	Jm		min J	max J
		lb-ft-s ²	0.00037	0.00079
		kg-m ²	0.00051	0.00108
Motor Weight	Wt	lb	12.9	
			14.8	
		kg	5.9	

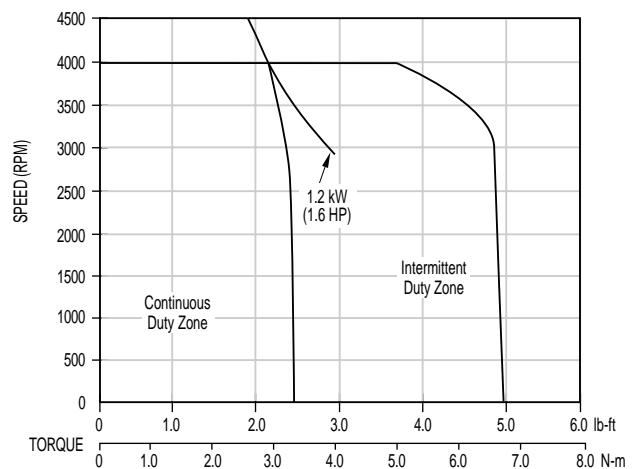

9 n Motor MT504A n Amplifier: S606

Performance Specification	Symbol	Units	Value	
Cont. Torque at stall	Tc	lb-ft	4.79	
		N-m	6.50	
Peak Torque at stall	Tp	lb-ft	9.15	
		N-m	12.41	
Cont. Power	HP rated	HP	1.9	
	kW rated	kWatts	1.4	
Rated Speed	Nr	RPM	2400	
Max. Speed	Nmax	RPM	2400	
Motor Inertia	Jm		min J	max J
		lb-ft-s ²	0.00069	0.00154
		kg-m ²	0.00093	0.00208
Motor Weight	Wt	lb	17.6	
			20.1	
		kg	8.0	

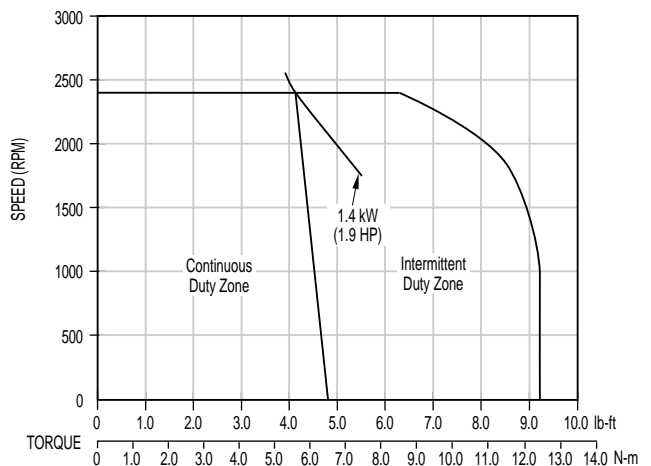

Notes:

1. Continuous duty operation is with motor mounted to aluminum faceplate of 300 in², in 40° C ambient.
2. All curves shown at 60 Hz input, derate max. speed and peak power by 15% for 50 Hz operation.
3. All curves represent typical performance. Always allow appropriate safety factor when sizing systems.

Kollmorgen GOLDLINE XT and SERVOSTAR 600

SYSTEM PERFORMANCE CURVES

10 n Motor MT504B n Amplifier: S610

Performance Specification	Symbol	Units	Value	
Cont. Torque at stall	Tc	lb-ft	4.87	
		N-m	6.60	
Peak Torque at stall	Tp	lb-ft	9.51	
		N-m	12.9	
Cont. Power	HP rated	HP	2.5	
	kW rated	kWatts	1.9	
Rated Speed	Nr	RPM	4000	
Max. Speed	Nmax	RPM	4000	
Motor Inertia	Jm		min J	max J
		lb-ft-s ²	0.00069	0.00154
		kg-m ²	0.00093	0.00208
Motor Weight	Wt	lb	17.6	
		kg	8.0	

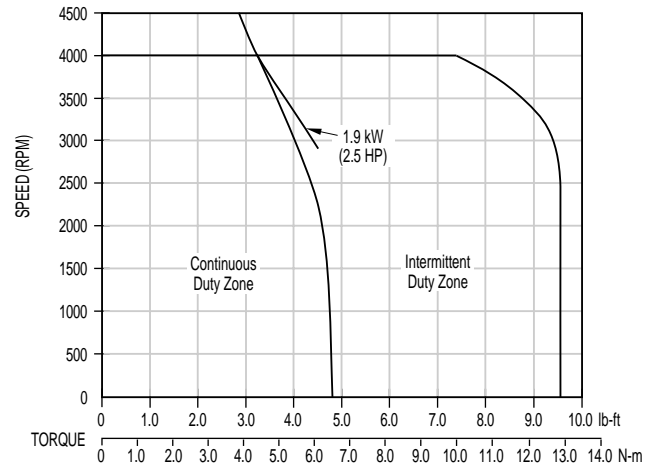

11 n Motor MT506A n Amplifier: S610

Performance Specification	Symbol	Units	Value	
Cont. Torque at stall	Tc	lb-ft	8.04	
		N-m	10.9	
Peak Torque at stall	Tp	lb-ft	17.8	
		N-m	24.1	
Cont. Power	HP rated	HP	3.0	
	kW rated	kWatts	2.2	
Rated Speed	Nr	RPM	2300	
Max. Speed	Nmax	RPM	2300	
Motor Inertia	Jm		min J	max J
		lb-ft-s ²	0.00134	0.00254
		kg-m ²	0.00181	0.00345
Motor Weight	Wt	lb	24.2	
		kg	11.0	

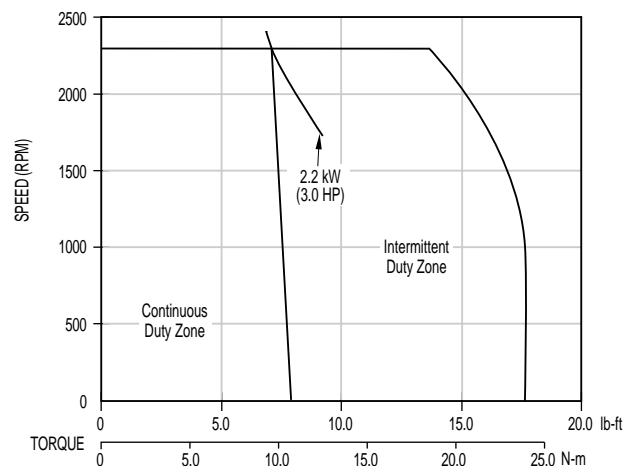

12 n Motor MT506B n Amplifier: S614/S620

Performance Specification	Symbol	Units	Value S614	Value S620
Cont. Torque at stall	Tc	lb-ft	7.15	8.04
		N-m	9.70	10.90
Peak Torque at stall	Tp	lb-ft	13.1	18.4
		N-m	17.7	24.9
Cont. Power	HP rated	HP	4.2	4.2
	kW rated	kWatts	3.1	3.1
Rated Speed	Nr	RPM	4000	4000
Max. Speed	Nmax	RPM	4000	4000
Motor Inertia	Jm		min J	max J
		lb-ft-s ²	0.00134	0.00254
		kg-m ²	0.00181	0.00345
Motor Weight	Wt	lb	24.2	
		kg	11.0	

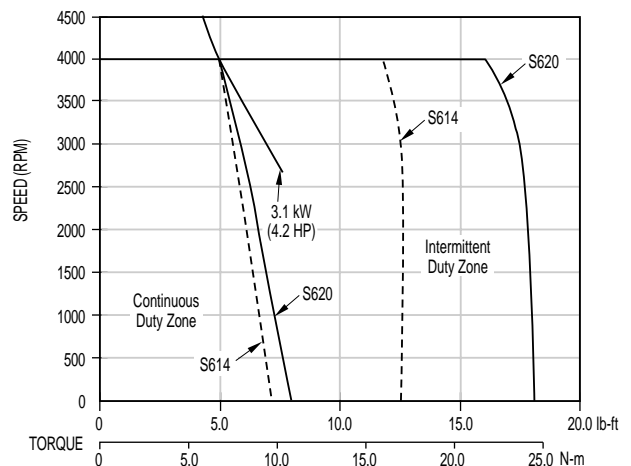

Notes:

1. Continuous duty operation is with motor mounted to aluminum faceplate of 300 in², in 40° C ambient.
2. All curves shown at 60 Hz input, derate max. speed and peak power by 15% for 50 Hz operation.
3. All curves represent typical performance. Always allow appropriate safety factor when sizing systems.

Kollmorgen GOLDLINE XT and SERVOSTAR 600

SYSTEM PERFORMANCE CURVES

13 Motor MT702A Amplifier: S620

Performance Specification	Symbol	Units	Value	
Cont. Torque at stall	Tc	lb-ft	16.5	
		N-m	22.3	
Peak Torque at stall	Tp	lb-ft	35.6	
		N-m	48.3	
Cont. Power	HP rated	HP	5.2	
		kW rated	kWatts	3.9
Rated Speed	Nr	RPM	2200	
Max. Speed	Nmax	RPM	2200	
Motor Inertia	Jm		min J	max J
		lb-ft-s ²	0.00398	0.0096
		kg-m ²	0.00540	0.0130
Motor Weight	Wt	lb	49.6	
			53.4	
		kg	22.5	

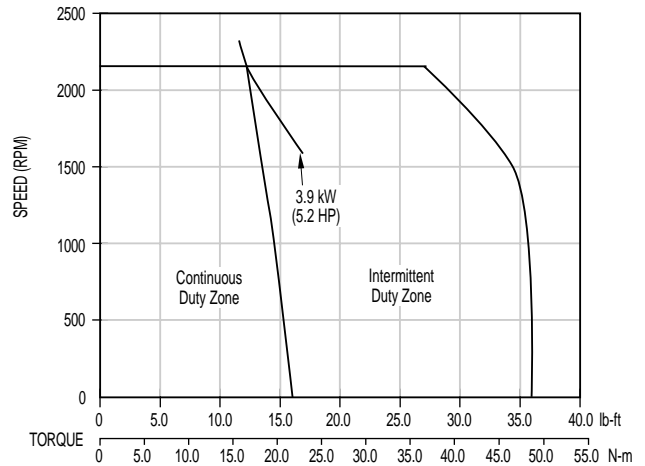

14 Motor MT704A Amplifier: S620

Performance Specification	Symbol	Units	Value	
Cont. Torque at stall	Tc	lb-ft	23.1	
		N-m	31.4	
Peak Torque at stall	Tp	lb-ft	41.2	
		N-m	55.9	
Cont. Power	HP rated	HP	6.3	
		kW rated	kWatts	4.7
Rated Speed	Nr	RPM	2000	
Max. Speed	Nmax	RPM	2000	
Motor Inertia	Jm		min J	max J
		lb-ft-s ²	0.0058	0.0140
		kg-m ²	0.0078	0.0189
Motor Weight	Wt	lb	66.1	
			79.3	
		kg	30.0	

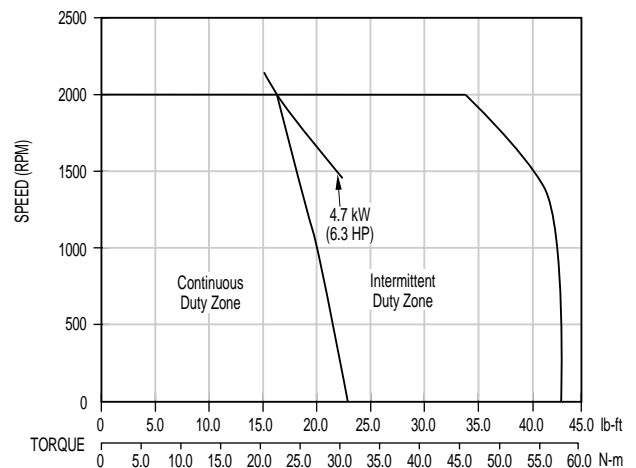

15 Motor MT706C Amplifier: S620

Performance Specification	Symbol	Units	Value	
Cont. Torque at stall	Tc	lb-ft	35.4	
		N-m	48.0	
Peak Torque at stall	Tp	lb-ft	63.8	
		N-m	86.5	
Cont. Power	HP rated	HP	7.8	
		kW rated	kWatts	5.8
Rated Speed	Nr	RPM	1300	
Max. Speed	Nmax	RPM	1300	
Motor Inertia	Jm		min J	max J
		lb-ft-s ²	0.0093	0.0176
		kg-m ²	0.0126	0.0239
Motor Weight	Wt	lb	79.3	
			92.5	
		kg	36.0	

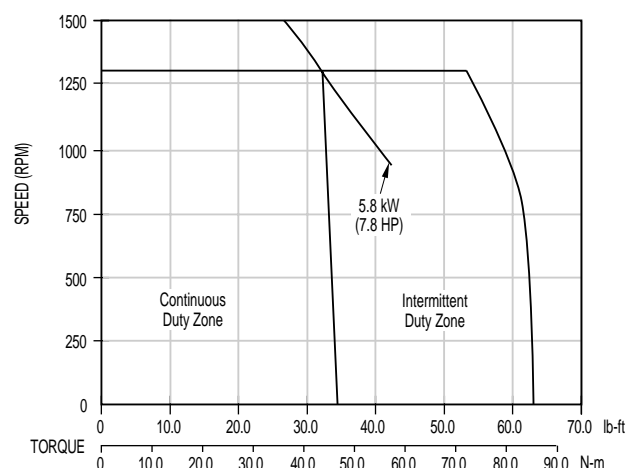

Notes:

1. Continuous duty operation is with motor mounted to aluminum faceplate of 400 in², in 40° C ambient.
2. All curves shown at 60 Hz input, derate max. speed and peak power by 15% for 50 Hz operation.
3. All curves represent typical performance. Always allow appropriate safety factor when sizing systems.

Kollmorgen GOLDLINE XT

DIMENSIONS

MT(x)30x

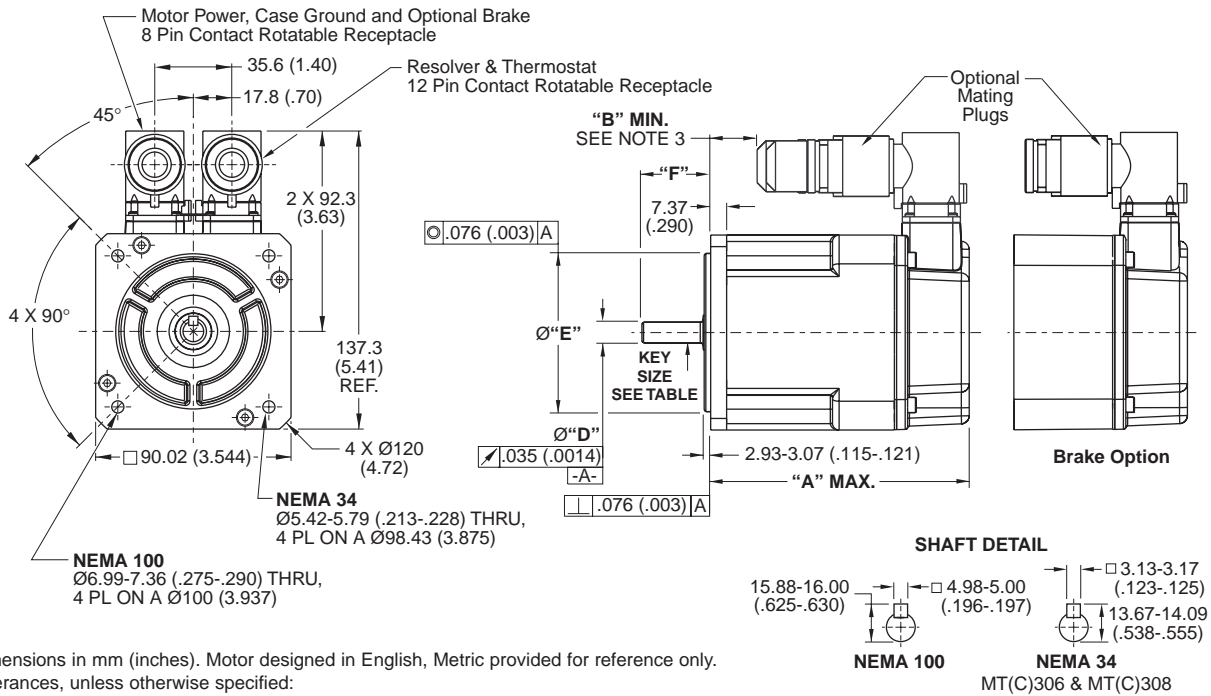

Model	"A" MAX.		"B" MIN.		"D"		"E"		"F" $\pm .76$ ($\pm .030$)		Key Length	
	with brake	without brake	with brake	without brake	NEMA 34	NEMA 100	NEMA 34	NEMA 100	NEMA 34	NEMA 100	NEMA 34	NEMA 100
MT(C)302	165.6 (6.520)	120.1 (4.730)	65.14 (2.565)	19.93 (.785)	9.512-9.525 (.3745-.3750)	14.01	73.05	80.03			no keyway	20 (.79)
MT(C)304	183.1 (7.210)	137.7 (5.420)	82.67 (3.255)	37.46 (1.475)		13.99	73.00	79.99	31.75	30		20 (.79)
MT(C)306	198.6 (7.820)	153.2 (6.030)	98.16 (3.865)	52.95 (2.085)	12.69-12.70 (.4995-.5000)	(.5515)	(2.876)	(3.151)	(1.250)	(1.181)	19 (.75)	20 (.79)
MT(C)308	231.7 (9.120)	186.2 (7.330)	131.2 (5.165)	85.97 (3.385)		(.5511)	(2.874)	(3.149)			19 (.75)	20 (.79)

CONNECTOR PIN OUTS

Connections:

Motor Receptacle:

Pin 1	- Phase U (white, C)
Pin 4	- Phase V (red, B)
Pin 3	- Phase W (brown, A)
Pin 2	- Ground (PE) (green/yellow)
Pin A	- (Optional) Brake (blue)
Pin B	- (Optional) Brake (blue) (brake not polarity sensitive)

Resolver Receptacle:

Pin 9	- (red/white), Ref. Lo
Pin 5	- (yellow/white), Ref. Hi
Pin 7	- (red) Sin Lo
Pin 3	- (black), Sin Hi
Pin 8	- (yellow) Cos Hi
Pin 4	- (blue), Cos Lo
Pin 2	- Thermostat (yellow)
Pin 6	- Thermostat (yellow)

Mating Connector Cable Set p/n: CS-SS-RHG1HE-xx

Kollmorgen GOLDLINE XT

DIMENSIONS

MT(x)50x with resolver, 20 AMP Max.

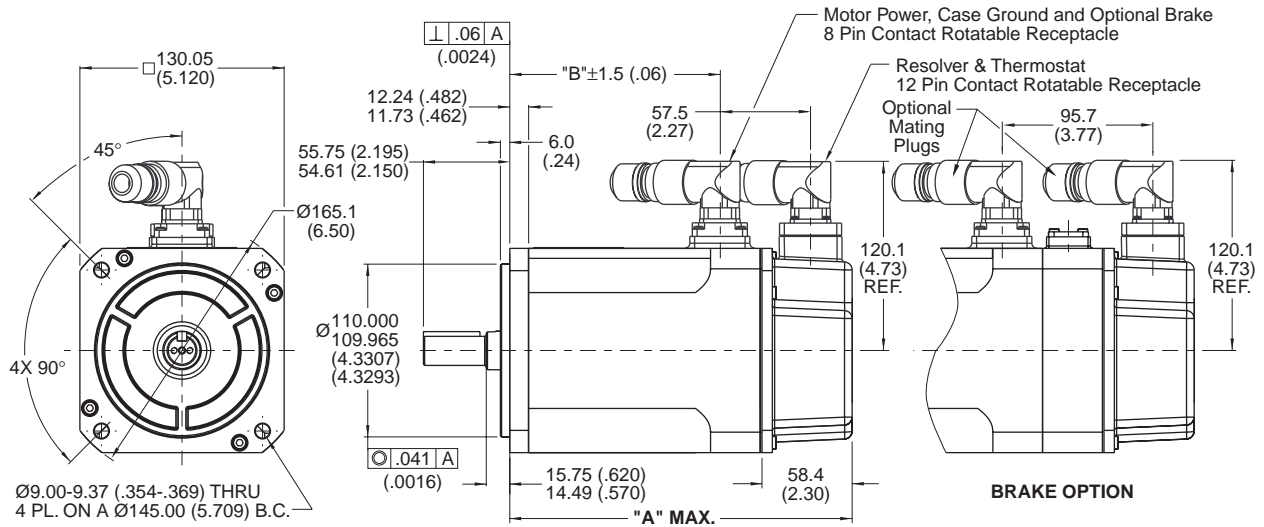

STRAIGHT SHAFT KEYWAY OPTION

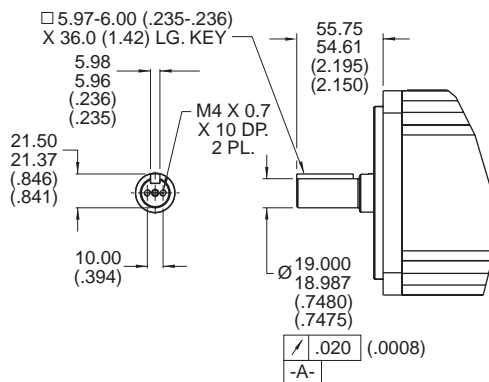

TAPERED SHAFT OPTION

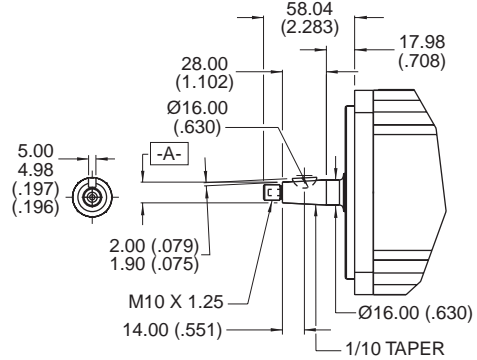

Notes:

- Dimensions in mm (inches). Motor designed in English, Metric provided for reference only.
- Tolerances, unless otherwise specified:
Angle dimension $\pm 1^\circ$, XX decimal places $\pm .38$ (.015), XXX decimal places $\pm .127$ (.005)

Model	"A" Max		"B"
	with brake	without brake	
MT(x)502	220.0 (8.665)	181.9 (7.160)	98 (3.84)
MT(x)504	256.6 (10.102)	218.4 (8.597)	134 (5.28)
MT(x)506	301.8 (11.882)	263.6 (10.377)	179 (7.06)

CONNECTOR PIN OUTS

Connections:

Motor Receptacle:

Pin 1	- Phase U (white, C)
Pin 4	- Phase V (red, B)
Pin 3	- Phase W (brown, A)
Pin 2	- Ground (PE) (green/yellow)
Pin A	- (Optional) Brake (blue)
Pin B	- (Optional) Brake (blue) (brake not polarity sensitive)

Resolver Receptacle:

Pin 9	- (red/white), Ref Lo
Pin 5	- (yellow/white), Ref. Hi
Pin 7	- (red) Sin Lo
Pin 3	- (black), Sin Hi
Pin 8	- (yellow) Cos Hi
Pin 4	- (blue), Cos Lo
Pin 2	- Thermostat (yellow)
Pin 6	- Thermostat (yellow)

Mating Connector Cable Set p/n:

MT502A & B, MT504A & B, and MT506A use CS-SS-RHG1HE-xx
MT506B use CS-SS-RHG2HE-xx

Kollmorgen GOLDLINE XT

DIMENSIONS

MT(x)70x with resolver, 20 AMP Max.

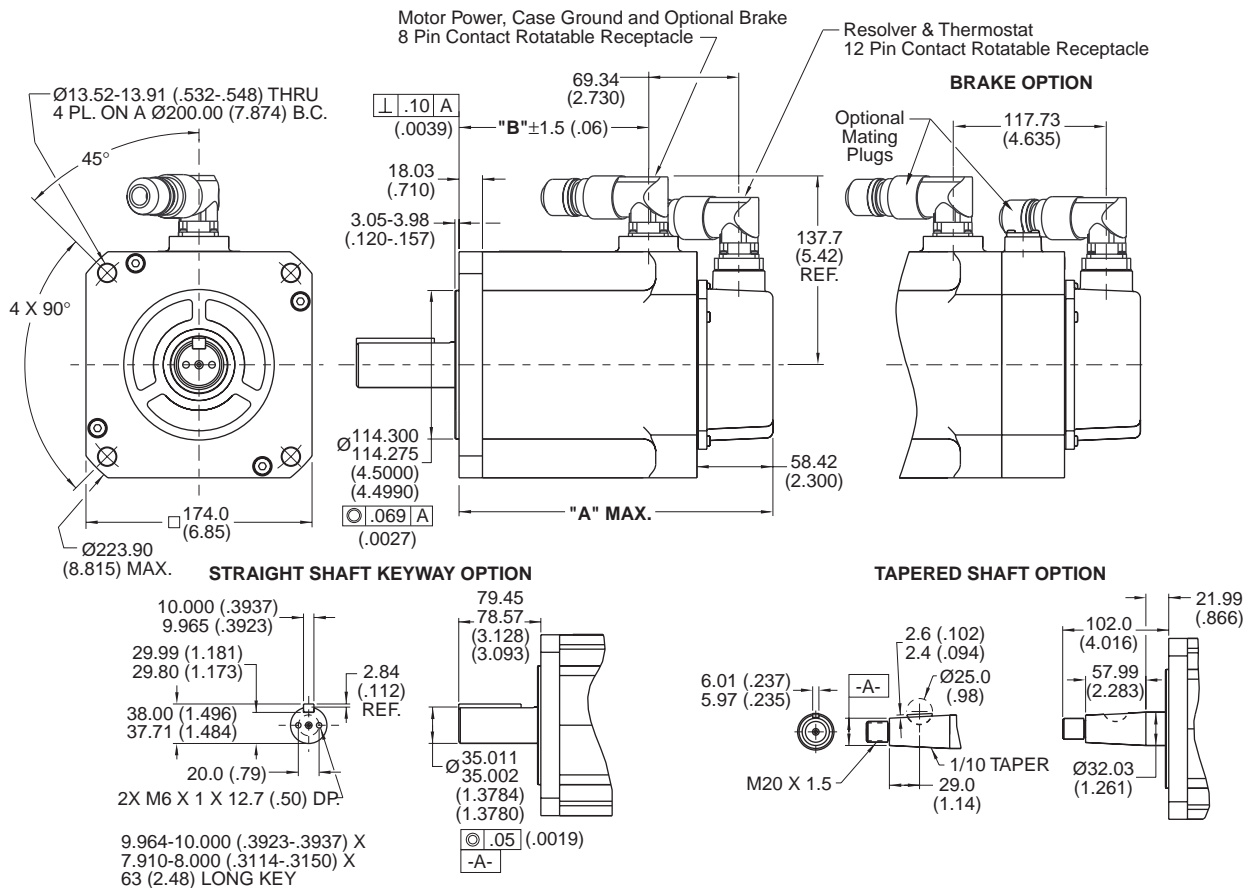

Notes:

- Dimensions in mm (inches). Motor designed in English, Metric provided for reference only.
- Tolerances, unless otherwise specified:
Angle dimension $\pm 1^\circ$, XX decimal places $\pm .38$ (.015),
XXX decimal places $\pm .127$ (.005)
- For MT(x)70x-RxCx models 20A-40A, the connector configuration is different. The power connector is larger and a separate brake connector is used.

Model	"A" Max		"B"
	with brake	without brake	
MT(x)702	349.66 (13.766)	301.19 (11.858)	205.0 (8.07)
MT(x)704	410.54 (16.163)	362.03 (14.253)	265.9 (10.47)
MT(x)706	470.54 (18.525)	422.02 (16.615)	326.1 (12.84)

CONNECTOR PIN OUTS

Connections:

Motor Receptacle:

Pin 1	- Phase U (white, C)
Pin 4	- Phase V (red, B)
Pin 3	- Phase W (brown, A)
Pin 2	- Ground (PE) (green/yellow)
Pin A	- (Optional) Brake (blue)
Pin B	- (Optional) Brake (blue) (brake not polarity sensitive)

Resolver Receptacle:

Pin 9	- (red/white), Ref Lo
Pin 5	- (yellow/white), Ref. Hi
Pin 7	- (red) Sin Lo
Pin 3	- (black), Sin Hi
Pin 8	- (yellow) Cos Hi
Pin 4	- (blue), Cos Lo
Pin 2	- Thermostat (yellow)
Pin 6	- Thermostat (yellow)

Mating Connector Cable Set p/n: **CS-SS-RHG2HE-xx**

Kollmorgen GOLDLINE XT and SERVOSTAR 600

SYSTEM SUMMARY

System Summary and Configurations

Motor	Continuous Torque lb-ft (N-m)	Peak Torque lb-ft (N-m)	Continuous Power HP (kW)	Rated Speed RPM	Max Speed RPM	Amplifier	Amplifier Cont/Peak Current (RMS/Phase)	Cable Set	Curve Number
MT302A1-RxCx	0.95 (1.29)	1.75 (2.37)	0.79 (0.59)	4500	4500	S60301	3/6	CS-SS-RHG1HE-xx	1
MT304A1-RxCx	1.86 (2.52)	3.62 (4.91)	0.95 (0.71)	3000	3000	S60301	3/6	CS-SS-RHG1HE-xx	2
MT304B1-RxCx	1.81 (2.45)	3.78 (5.13)	1.8 (1.3)	6000	6000	S60601	6/12	CS-SS-RHG1HE-xx	3
MT306A1-RxCx	2.49 (3.50)	4.93 (6.69)	1.1 (0.82)	2500	2500	S60301	3/6	CS-SS-RHG1HE-xx	4
MT306B1-RxCx	2.45 (3.32)	4.96 (6.73)	2.0 (1.5)	4600	4600	S60601	6/12	CS-SS-RHG1HE-xx	5
MT308B1-RxCx	3.53 (4.79)	7.21 (9.77)	1.7 (1.3)	3000	3000	S60601	6/12	CS-SS-RHG1HE-xx	6
MT502A1-RxCx ³	2.40 (3.30)	4.60 (6.20)	1.1 (0.80)	2400	2400	S60301	3/6	CS-SS-RHG1HE-xx	7
MT502B1-RxCx ³	2.40 (3.30)	5.00 (6.80)	1.6 (1.2)	4000	4000	S60601	6/12	CS-SS-RHG1HE-xx	8
MT504A1-RxCx ³	4.80 (6.50)	9.20 (12.4)	1.9 (1.4)	2400	2400	S60601	6/12	CS-SS-RHG1HE-xx	9
MT504B1-RxCx ³	4.90 (6.60)	9.50 (12.9)	2.5 (1.9)	4000	4000	S61001	10/20	CS-SS-RHG1HE-xx	10
MT506A1-RxCx ³	8.00 (10.9)	17.8 (24.1)	3.0 (2.2)	2300	2300	S61001	10/20	CS-SS-RHG1HE-xx	11
MT506B1-RxCx ³	7.20 (9.70)	13.1 (17.7)	4.2 (3.1)	4000	4000	S61401	14/28	CS-SS-RHG2HE-xx	12
MT506B1-RxCx ³	8.10 (10.9)	18.4 (24.9)	4.2 (3.1)	4000	4000	S62001	20/40	CS-SS-RHG2HE-xx	12
MT702A1-RxCx ³	16.5 (22.3)	35.6 (48.3)	5.2 (3.9)	2200	2200	S62001	20/40	CS-SS-RHG2HE-xx	13
MT704A1-RxCx ³	24.2 (32.8)	41.2 (55.9)	6.3 (4.7)	2000	2000	S62001	20/40	CS-SS-RHG2HE-xx	14
MT706C1-RxCx ³	35.4 (48.0)	63.8 (86.5)	7.8 (5.8)	1300	1300	S62001	20/40	CS-SS-RHG2HE-xx	15

Notes:

1. Cable "-xx" designates length in meters. Standard lengths available are 3 m (-03), 6 m (-06), and 9 m (-09). Maximum length is 75 m.
2. Cable p/n shown is for motor without brake. For motor with brake, use cable p/n: CS-SS-RHGAHBE-xx for amplifiers thru S610, and use cable p/n: CS-SS-RHGBHBE-xx for amplifiers S614 and S620.
3. Part numbers are for minimum inertia models. For maximum inertia: MTxxxx2

Electrically Released Brake

Motor	Input Voltage ¹ VDC	Input Current ¹ ADC	Static Holding Torque ² lb-ft (N-m)	Inertia lb-ft-s ² (kg-m ²)	Max Speed RPM
MTC3xxxx	24	0.75	4.4 (5.97)	.0000125 (.0000169)	6000
MTC5xxxx	24	0.30	14.4 (19.5)	.00010 (.00014)	6000
MTC7xxxx	24	1.40	53.8 (73.0)	.00059 (.00080)	6000

¹ ±10% on inputs

² Static holding torque only. Must not be used for dynamic braking.

Kollmorgen GOLDLINE XT and SERVOSTAR 600

ORDERING INFORMATION

Kollmorgen GOLDLINE® XT

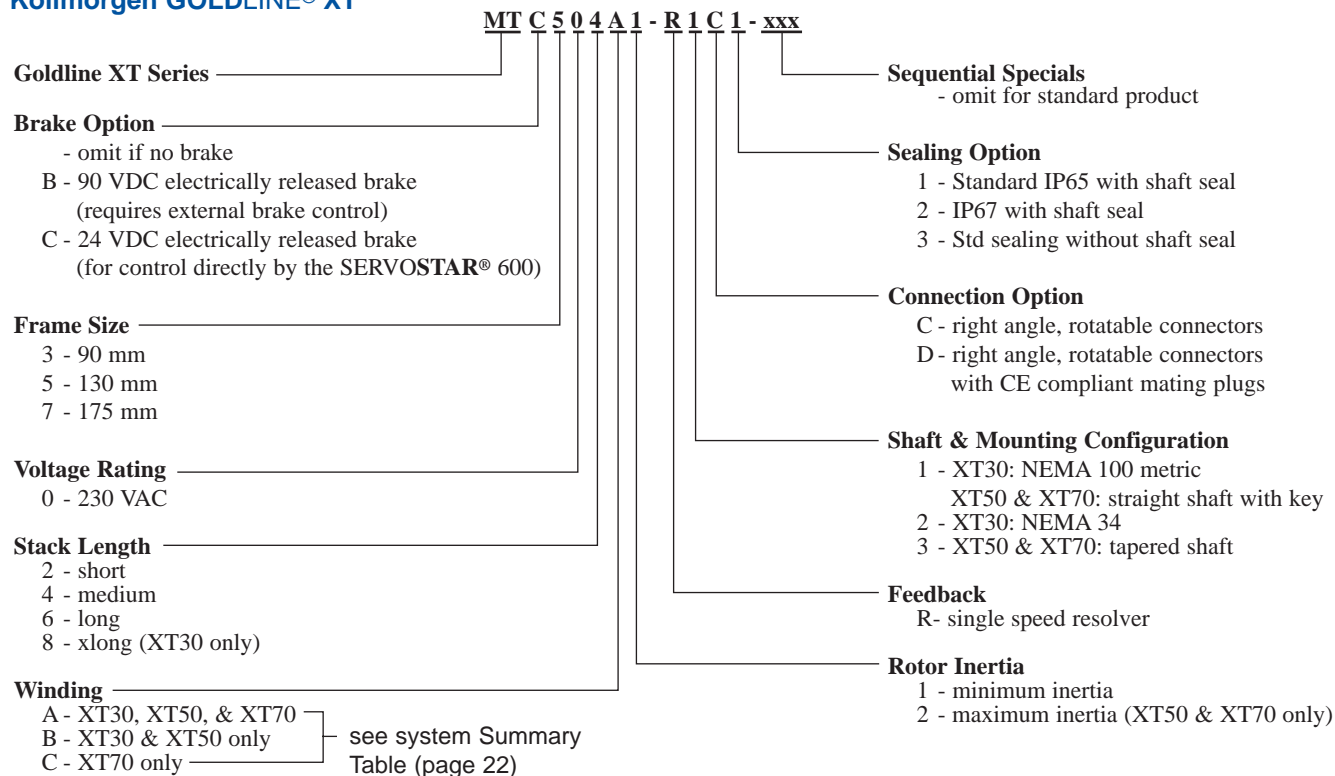

SERVOSTAR 600

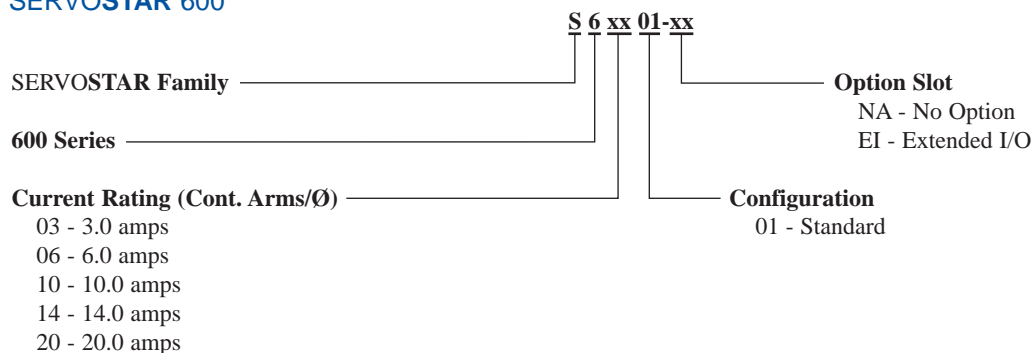

Accessories

	Model Number	Description
External Regen Resistors (in housing):	BAR-250	250 watts
	BAR-500	500 watts
	BAR-1500	1500 watts
Communication Cables:	A-97251-004	RS-232 (9 pin) communication cable
	A-SR6Y	Y- adapter cable with 5 DB9 connectors for connecting PC up to 4 drives, includes termination
Motor-Drive Cable Set: (power cable & resolver cable)	CS-SS-RHG2HE-xx	For use with S603-S610
Motor- Mating Connector Kit:	CS-SS-RHG1HE-xx	For use with S614-S620
	CKT-T3A-SRE	Power plug & resolver plug; with crimp style pins

Note: XT Series motors are available with modified mechanicals including special shafts and keyways. Contact the Kollmorgen Customer Support Network (1-800-77 SERVO) for more information.

Kollmorgen Sales Offices

E-mail: servo@kollmorgen.com

Internet: <http://www.kollmorgen.com>

Motion Technologies Group

1-800-77 SERVO

E-mail: servo@kollmorgen.com

Americas

Radford, VA

Tel: (800) 77 SERVO

Fax: (540) 639-1640

Europe & Middle East

Duesseldorf, Germany

Tel: (49) 203 9979 0

Fax: (49) 203 9979 155

Asia Pacific & Far East

Tianjin, China

Tel: (86) 22 2627 1090

Fax: (86) 22 2627 1093

Kollmorgen Manufacturing Locations

Kollmorgen Artus

Avrillé, France

Ho Chi Minh City, Vietnam

Kollmorgen PMI

Commack, NY

Kollmorgen Electro-Optical

Northampton, MA

Kollmorgen Seidel

Duesseldorf, Germany

Kollmorgen Industrial Drives

Radford, VA

Kollmorgen Servotronix

Tel Aviv, Israel

Kollmorgen Inland Motor

Radford, VA

Kollmorgen Tandon Inc

Bombay, India

Kollmorgen Magnedyne

Vista, CA

Kollmorgen Tianjin Industrial Drives

Tianjin, China

Kollmorgen enjoys a reputation of excellence based on constant endeavors to update products. Information in this brochure is subject to change.

Windows is a registered trademark of Microsoft Corporation.
Kollmorgen SERVOSTAR®, MOTIONLINK®, Kollmorgen GOLDLINE®,
and MOTIONEERING are trademarks of Kollmorgen.

KOLLMORGEN