

Data  
Publication

# Kollmorgen GOLDLINE™ XT Brushless Series Motors *70 Frame Size*



The new, performance driven Kollmorgen **GOLDLINE XT** servomotor extends the traditional Kollmorgen **GOLDLINE** series' application capabilities. Kollmorgen's patented buried magnet design provides the lowest cogging/torque ripple system on the market. A high resolution encoder (8192 pulses per rev) provides resolution and accuracy not available from standard encoder or resolver based systems. Increased thermal time constants allow longer overloads on machines. The XT also sets a new standard in precision machining of mechanical mountings. Tolerances nearly half of NEMA standards help to reduce vibration and noise and increase the life of customer assemblies. Shaft runout, perpendicularity, and concentricity are all improved over industry standards.

The Kollmorgen **GOLDLINE XT** is fully compatible with Kollmorgen's **SERVOSTAR** digital amplifiers.

**KOLLMORGEN**

# Kollmorgen GOLDLINE XT

## 70X PERFORMANCE DATA

Parameters	Symbols	Units	MT702A1	MT702B1	MT704A1
Horsepower	HP Rated	HP	5.1	6.2	6.0
Kilowatts	kW Rated	kW	3.8	4.6	4.5
Speed at Rated Power	N Rated	RPM	2000	3000	2000
(1) Max Operating Speed	N Max	RPM	2000	3000	2000
(2) Continuous Torque (Stall) at 40°C	Tc	lb-ft	16.2	16.2	22.1
		N-m	22.0	22.0	30.0
Continuous Torque (Stall) at 25°C	Tc	lb-ft	17.2	17.2	23.5
		N-m	23.4	23.4	32.0
Continuous Line Current	Ic	Amps RMS	16.4	25.2	19.3
Peak Torque	Tp	lb-ft	41.4	41.3	56.2
		N-m	56.1	56.0	76.2
Peak Line Current	Ip	Amps RMS	51.1	78.3	60.0
Max Theoretical Acceleration	Z	rad / sec <sup>2</sup>	10890	10865	10013
Torque Sensitivity (Stall) ±10%	Kt	lb-ft / Amp RMS	0.99	0.65	1.15
		N-m / Amp RMS	1.34	0.87	1.55
Back EMF (Line-to-Line) ±10%	Kb	VRMS / kRPM	81.3	52.9	94.0
Max Line-to-Line Volts	VMax	Volts RMS	250	250	250
DC Res at 25°C (Line-to-Line) ±10%	Rm	Ohms	0.514	0.222	0.434
Inductance (Line-to-Line) ±30%	Lm	mh	14.6	6.2	13.0
Rotor Inertia	Jm	lb-ft-sec <sup>2</sup>	0.00380	0.00380	0.00561
		kg-m <sup>2</sup>	0.00515	0.00515	0.00761
Weight (without brake)	Wt	lb	49.6	49.6	66.1
		kg	22.5	22.5	30.0
Static Friction	Tf	lb-ft	0.175	0.175	0.260
		N-m	0.237	0.237	0.353
Thermal Time Constant	TCT	Min.	45	45	60
Viscous Damping Z Source	Fi	lb-ft / kRPM	0.084	0.084	0.124
		N-m / kRPM	0.114	0.114	0.168
Motor Constant at 25°C	Km	lb-ft / √Watts	1.471	1.457	1.851
		N-m / √Watts	1.99	1.98	2.5
Thermal Resistance at Stall	Rth	°C / Watt	0.333	0.327	0.284
Number of Poles			8	8	8

### How to Determine Your Speed/Torque Performance Curve

The performance curve is made up of six points:

Point	Key	Units
(1)	Max operating speed	RPM
(2)	Continuous stall torque	N-m
(3)	Rated torque	N-m
(4)	Max peak torque at max speed	N-m
(5)	Peak torque break point speed	RPM
(6)	Peak torque from drive/motor combination	N-m

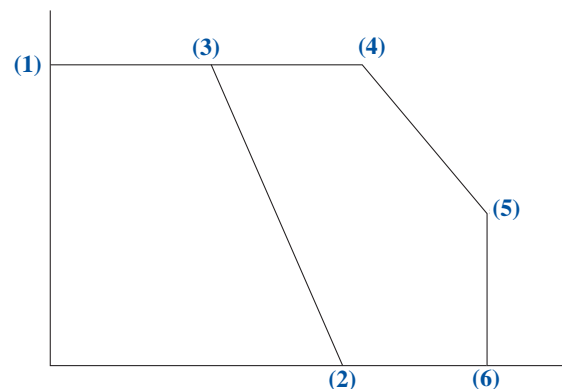

# Kollmorgen GOLDLINE XT

## 70X PERFORMANCE DATA

MT704B1	MT706A1	MT706B1	Units	Symbols	Parameters
8.0	8.2	9.0	HP	HP Rated	Horsepower
6.0	6.1	6.7	kW	kW Rated	Kilowatts
3000	2000	3000	RPM	N Rated	Speed at Rated Power
3000	2000	3000	RPM	N Max	Max Operating Speed (1)
22.1	32.5	32.5	lb-ft	Tc	Continuous Torque (Stall) (2)
30.0	44.0	44.0	N-m		at 40°C
23.5	34.6	34.6	lb-ft	Tc	Continuous Torque (Stall)
32.0	46.8	46.8	N-m		at 25°C
28.3	29.3	46.1	Amps RMS	Ic	Continuous Line Current
56.1	85.1	85.1	lb-ft	Tp	Peak Torque
76.1	115.4	115.4	N-m		
87.7	90.0	141.4	Amps RMS	Ip	Peak Line Current
9995	9331	9328	rad / sec <sup>2</sup>	Z	Max Theoretical Acceleration
0.78	1.11	0.70	lb-ft / Amp RMS	Kt	Torque Sensitivity (Stall) ±10%
1.06	1.50	0.95	N-m / Amp RMS		
64.2	90.7	57.7	VRMS / kRPM	Kb	Back EMF (Line-to-Line) ±10%
250	250	250	Volts RMS	VMax	Max Line-to-Line Volts
0.197	0.193	0.078	Ohms	Rm	DC Res at 25°C (Line-to-Line) ±30%
6.1	7.1	2.9	mh	Lm	Inductance (Line-to-Line) ±30%
0.00561	0.00912	0.00912	lb-ft-sec <sup>2</sup>	Jm	Rotor Inertia
0.00761	0.01237	0.01237	kg-m <sup>2</sup>		
66.1	79.3	79.3	lb	Wt	Weight (without brake)
30.0	36.0	36.0	kg		
0.260	0.431	0.431	lb-ft	Tf	Static Friction
0.353	0.584	0.584	N-m		
60	72	72	Min	TCT	Thermal Time Constant
0.124	0.207	0.207	lb-ft / kRPM	Fi	Viscous Damping Z Source
0.168	0.281	0.281	N-m / kRPM		
1.877	2.678	2.680	lb-ft / √Watts	Km	Motor Constant at 25°C
2.5	3.6	3.6	N-m / √Watts		
0.292	0.276	0.277	°C / Watt	Rth	Thermal Resistance at Stall
8	8	8			Number of Poles

### Follow these steps to calculate your speed/torque curve:

**Step 1:** Select max speed (1) from performance data

**Step 2:** Select continuous torque (2) from performance data

**Step 3:** Calculate rated torque (3) by using this formula:

$$\text{rated torque (N-m)} = \frac{\text{kW rated (from performance data)} \times 9550}{\text{N rated (from performance data)}}$$

**Step 4:** Calculate point four (4) by using this formula:

$$\text{max peak torque at max speed} = \text{rated torque (step 3)} \times 1.5$$

**Step 5:** Calculate point five (5) by using this formula:

$$\text{peak torque break point speed} = \text{max operating speed (step 1)} \times 0.4$$

**Step 6:** System peak torque is a function of the amplifier used with the motor winding.

Calculate system peak torque by using the following formula:

$$\text{system peak torque} = \frac{\text{Ip of drive}^* \times \text{Tp of motor (from performance data)}}{\text{Ip of motor (from performance data)}}$$

\*Not to exceed Ip of motor

# MT(x)70x Outline Drawing

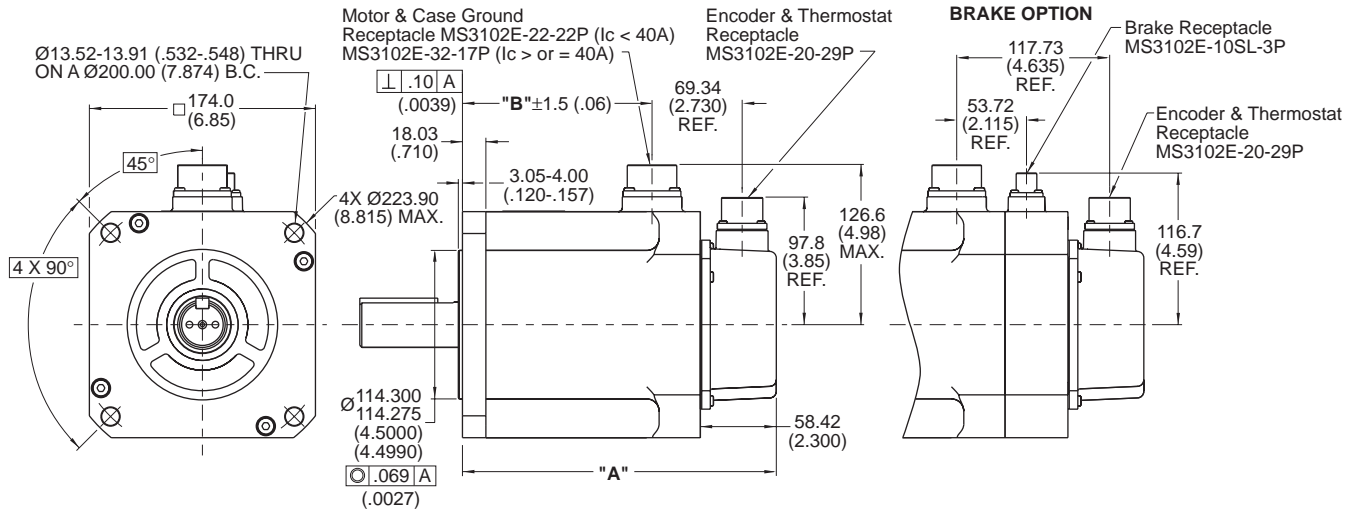

### STRAIGHT SHAFT KEYWAY OPTION

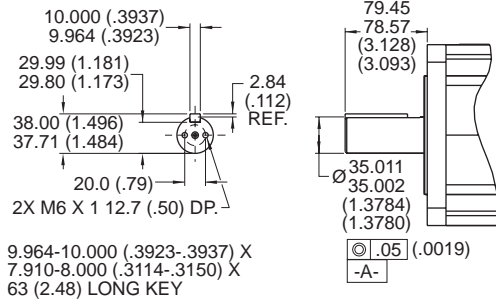

### TAPERED SHAFT OPTION

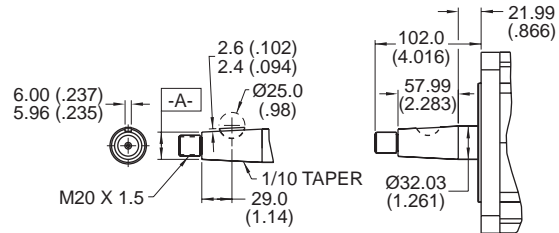

Dimensions in mm (inches)  
Motor designed in English, Metric provided for reference only.  
Tolerances, unless otherwise specified:  
metric: X decimal place  $\pm .4$ , XX decimal places  $\pm .13$   
inches: XX decimal places  $\pm .015$ , XXX decimal places  $\pm .005$

Model	"A" Max		"B"
	with brake	without brake	
MT(x)702	350 (13.78)	308 (12.1)	205 (8.071)
MT(x)704	411 (16.18)	369 (14.53)	265.89 (10.468)
MT(x)706	471 (18.54)	429 (16.89)	326.01 (12.835)

## Ordering Information

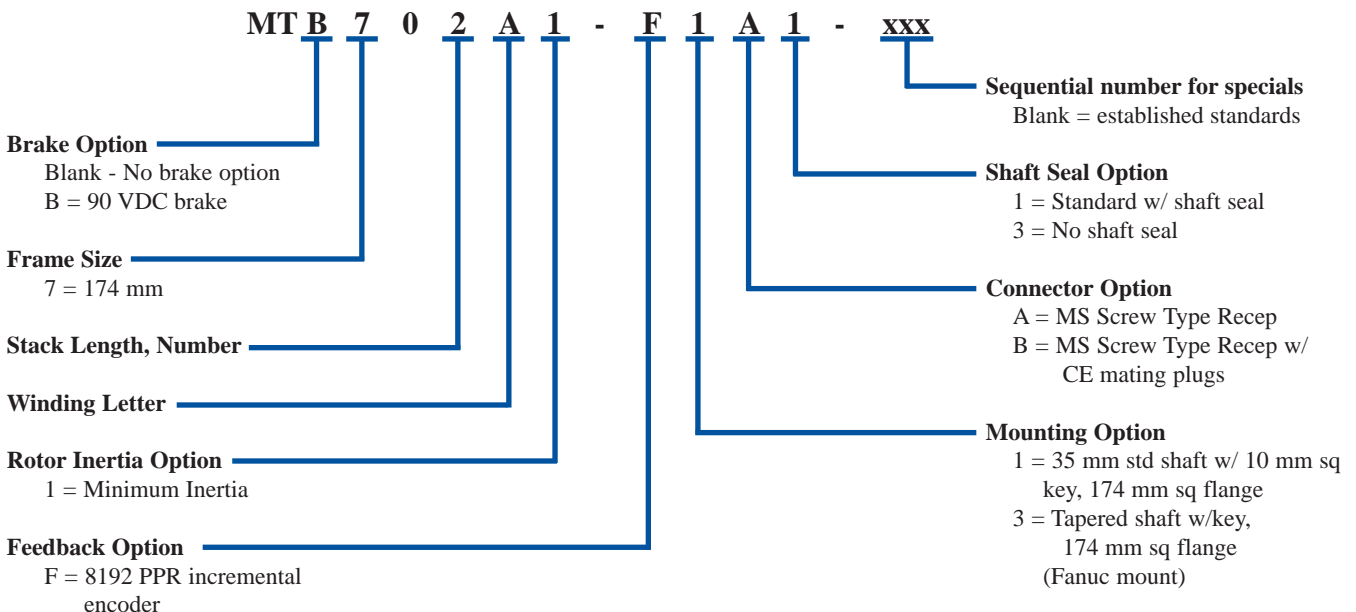

Kollmorgen enjoys a reputation of excellence based on constant endeavors to update products. Information in this brochure is subject to change.

E-mail: [servo@kollmorgen.com](mailto:servo@kollmorgen.com)  
Internet: [www.kollmorgen.com](http://www.kollmorgen.com)  
Fax: 1-540-731-0847

**KOLLMORGEN**

Radford, VA (USA) • 1-800-77 SERVO