

Kollmorgen Brushless Motor Amplifier EB-40X Series Motors Installation and Service Manual

Edition: September 2020, Revision B

Part Number: EB-9106

Original Document



For safe and proper use, follow these instructions. Keep for future use.

KOLLMORGEN[®]

Because Motion Matters™

Record of Document Revisions

Revision	Date	Remarks
1	05/1990	Initial Release
2	10/2004	Update corporate identity, contact information, change part number
B	09/2020	Rebrand, CE and Declaration of Conformity removed

IMPORTANT NOTICE

Copyright© Kollmorgen™ 1990 – 2020. All rights reserved.

Technical changes which improve the performance of the device may be made without prior notice!

This document is the intellectual property of Kollmorgen. All rights reserved. No part of this work may be reproduced in any form (by photocopying, microfilm or any other method) or stored, processed, copied or distributed by electronic means without the written permission of Kollmorgen.

SAFETY – READ ALL INSTRUCTIONS BEFORE INSTALLING THIS MOTOR

 **WARNING** Dangerous voltages exist in this equipment. Do not attempt connecting or probing this equipment with power on.

The fold back feature must limit the over current to no more that 300% of rated current for a maximum period of 8 seconds.

⚠ CAUTION

Do not install the amplifier in a hazardous (classified) location unless the amplifier is listed for such location. The motor is U.L. listed for class I, C, and D, but the amplifier might not be suitable for such locations.

Do not operate the motor outside the parameters shown on the respective performance curve.

Do not service unless area is known to be non-hazardous. Keep covers tight while circuits are live.

Connect internal thermostat to limit motor surface temperature.

Instructions are provided indicating that motor thermostat is an automatic resetting device.

NOTE

Upon receipt of the equipment, closely inspect the components to ensure that no damage has occurred in shipment. If damage has occurred, notify the appropriate carrier at once.

Save these instructions for future reference. Should any question arise regarding any step outlined in this manual, please call the factory.

Proprietary Information of the Kollmorgen Corporation is furnished for customer user only. No other uses are authorized without written permission of Kollmorgen.

1	INTRODUCTION	6
1.1	Amplifier and Power Supply Ratings.....	7
2	WIRING	8
2.1	Typical Amplifier	9
2.1.1	Outline Dimensions	9
2.1.2	Front View	10
2.1.3	Side View	10
2.2	Typical Power Supply.....	11
2.2.1	Outline Dimensions	11
2.2.2	Front View	12
2.2.3	Side View	12
2.3	System Wiring	13
2.4	Typical Motor Connections	23
2.5	3 Phase Power Transformer	26
2.6	Grounding	24
2.7	Inputs	24
2.8	Preliminary Checks	25
2.8.1	Checking AC Input Voltage.....	25
2.8.2	Checking Power Supply DC Output Voltage	25
3.	MOTOR DATA PACKAGE	28
3.1	Model Number System	28
3.2	Outline Drawing.....	29
3.2.1	EB-40X-X-11	29
3.2.2	EB-40X-X-11-B()R	30
3.3	EB-402	31
3.3.1	Specifications CD-27010	31
3.3.2	Performance Curves	33
3.4	EB-404	36
3.4.1	Specifications CD 27011.....	36
3.4.2	Performance Curves	38
3.5	EB-406	42
3.5.1	Specifications CD 27012.....	42

- 3.6 EB-40x Typical Current and Voltage (Wave Forms at Motor) 48
 - 3.6.1 Current Phase C 48
 - 3.6.2 Voltage line a-c 48
- 3.7 EB-40x Intermittent Duty Operation 48
- 4. TYPICAL AMPLIFIER DATA PACKAGE..... 53**
 - 4.1 Typical Amplifier Specifications 53
- 5 INDEX..... 54**

1 INTRODUCTION

This installation and service manual is a general document and is applicable to a typical amplifier needed to properly control the EB-40X motor series. However, since these motor amplifiers interface with motors of varying sizes having different operating characteristics such as internal resistance, inductance, rotor inertia, etc., these amplifiers vary more or less with the motors with which they are compatible. Consult the manufacturer of the amplifier for the installation and service manual pertaining to the specific amplifier used. After the typical amplifier and a particular motor are connected together, the motor must perform per the motor's nameplate data.

The customer data (CD) and performance curve (PC) are specified documents and are applicable only to individual motors. They contain such information as maximum operating speed, peak current limits, and values, which make the amplifier motor combination compatible. Do not operate the motor outside the parameters shown on the respective performance curve.

Typical amplifiers are 3-phase sine wave, pulse-width modulated type. They are full regenerative, four-quadrant, bi-directional velocity loop amplifiers designed to be used with Kollmorgen high-performance permanent magnet brushless motors.

An unregulated 300 VDC bus, derived from full-wave rectification of a 3-phase 230 AC line by the power supply unit, is used to power the motor amplifier.

Kollmorgen brushless motors feature the latest in permanent magnet technology, utilizing high-energy Samarium-Cobalt and Neodymium-Iron-Boron alloys. These brushless motors consist of permanent magnet rotors and 3-phase Y-stator windings. Brushless motors have no commutators or associated brushes. These motors run as synchronous motors (the rotor speed is the same as the speed (frequency) of the rotating stator magnetic field). A brushless resolver is used as the feedback device and mounts internally as part of the overall motor construction.

Benefits of the typical amplifier and brushless motor construction are:

- Lower rotor inertia that permits higher acceleration rates.
- A more thermally efficient motor since all heat is generated in the stator windings (located in the outside shell).
- Higher speed operation and high peak horsepower because there is no commutation limit.
- Smaller physical motor size for a given HP rating.
- Higher reliability and less motor maintenance as there are no commutator or brushes.
- Smooth output torque.

1.1 Amplifier and Power Supply Ratings

Ratings		
Input Power:	235 V _{RMS} (L-L) 3-phase ($\pm 10\%$); isolation transformer not required – provided short circuit (inrush) current remains limited to less than 1000 amps. 115 VAC 1-phase control power.	
Output Power	Power Supply DC Bus	325 VDC nominal, no load
	Amplifier: at rated load	230 VRMS (L-L), Nominal $\pm 10\%$
	Continuous Current (ARMS/Phase)	Intermittent Current (5 sec. max., 30% duty cycle) (ARMS/Phase)
	As required to produce motors rated current	200% of continuous
Ambient Operating Temperature:	0-55° C	
Switching Frequency	10 kHz	
Cooling	Fan, Convection (cold plate)	

2 WIRING

NOTE

Install this motor and typical amplifier per the national electrical code.

To adhere to suitable engineering practices, connect the 115 VAC circuit so the 115 VAC is applied first to activate the control and fault circuits before applying the main bus voltage. Provide over-current protection based on continuous rated current per article 430 of the NEC. If the amplifier has the capability, adjust it accordingly. Otherwise, provide external protection.

Connect the motor using flying leads, where the leads of the 3-phase motor stator are color-coded and available directly out of the motor. See the **Error! Reference source not found.** for the correct method of wiring the motor stator. Connect the BROWN, RED and WHITE leads to the points identified as Ma, Mb, and Mc respectively on the power terminal block.

Bring the 3-phase 230 VAC input power through a customer supplied circuit breaker and connect to points identified as La, Lb and Lc on the power terminal block mounted on the power supply. The system is not AC line phase sensitive. Connect the 325 VDC output, the 115 VAC, and the regeneration circuit from the power supply to the amplifier with the strapping bars and the small 115 VAC and regen cable. Check to ensure that the small cable is connected to the correct pins and that it is not offset to one side. Perform the following steps:

1. Wire the typical amplifier control terminal strips per the diagram. Dress the wiring neatly so it does not to interfere with remounting the cover.
2. Unplug the C1, C2 and C3 point terminal strips from their connectors on the amplifier-motor control board to prevent over-flexing the board when wiring the connectors.
3. After unplugging the terminal strips from the motor control board, wire them per the appropriate wiring diagram.
4. Neatly dress the wire cable so it enters the amplifier chassis and does not interfere with the front cover. Dress signal cables separately and not with the AC or power wiring.
5. Leave a sufficient length in the wiring to allow the motor control board to slide out enough to expose the small compensation board. Insert the wired terminal strips back on their connectors.

The following precautions are also recommended:

1. Twist all AC leads to minimize electromagnetic emissions and pick-up. Maintain the shield over resolver leads.
2. Avoid running signal leads in close proximity to power leads, armature leads or other sources of electromagnetic noise.
3. Minimize lead lengths as much as is practical.
4. Double-check all interface wiring. Carefully inspect all connections.
5. Do not use main contactor for control functions.

⚠ CAUTION

Motor and resolver phasing are critical for proper operation

2.1 Typical Amplifier

2.1.1 Outline Dimensions

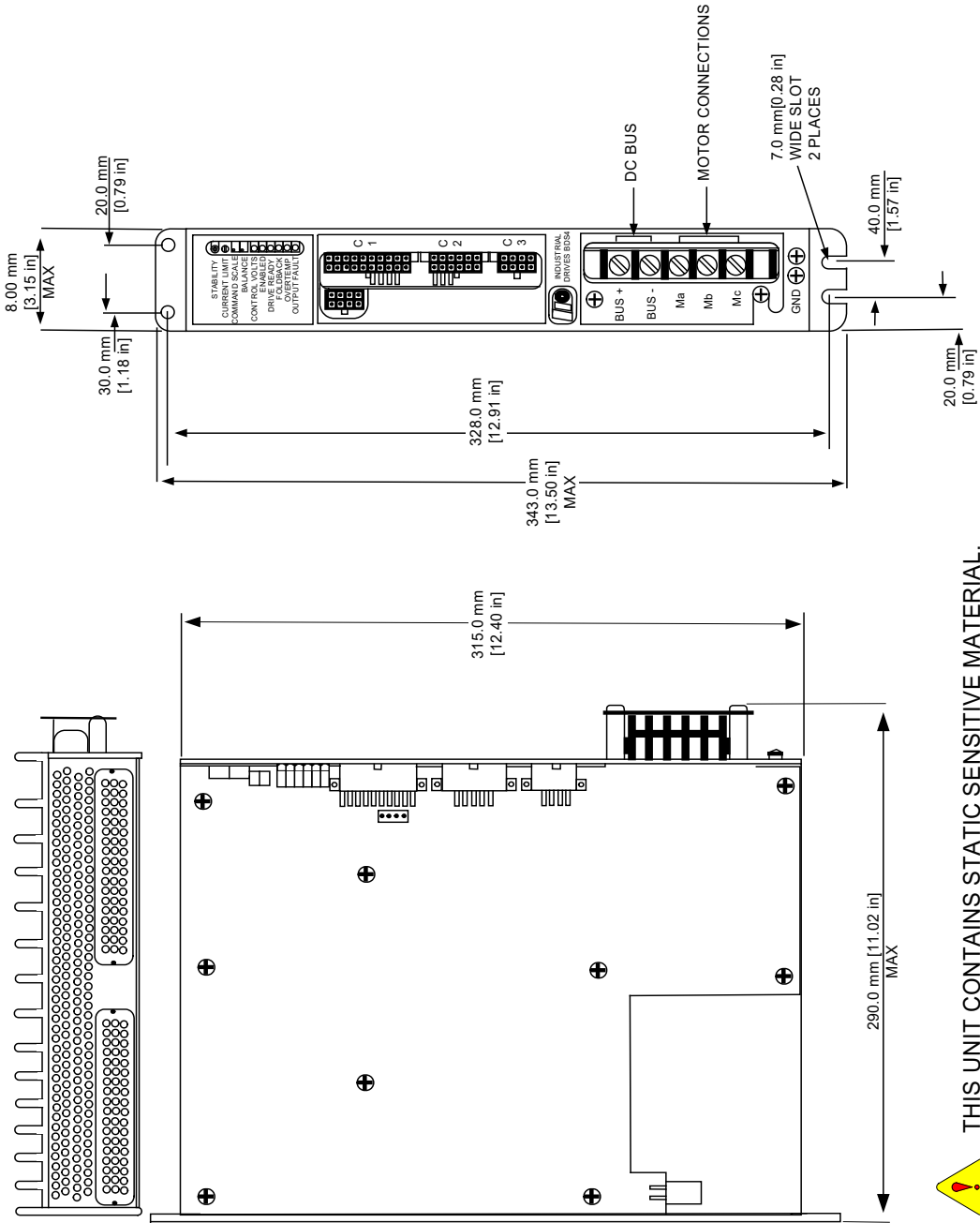

A-84032

⚠ THIS UNIT CONTAINS STATIC SENSITIVE MATERIAL. CAUTION HANDLE ACCORDINGLY.

2.1.2 Front View

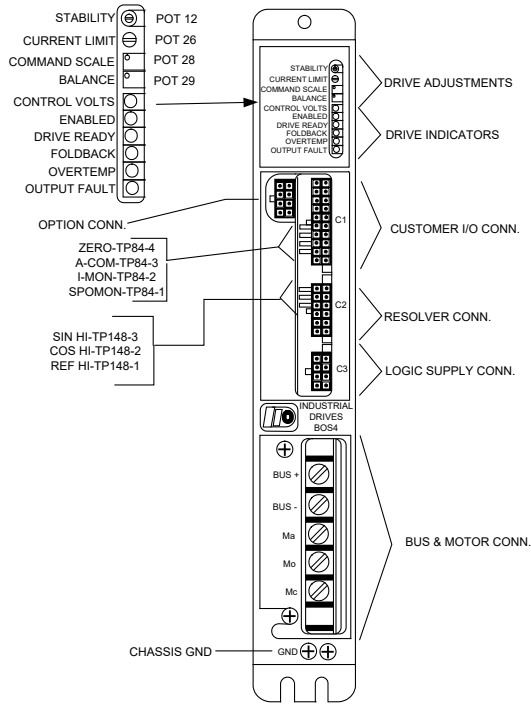

2.1.3 Side View

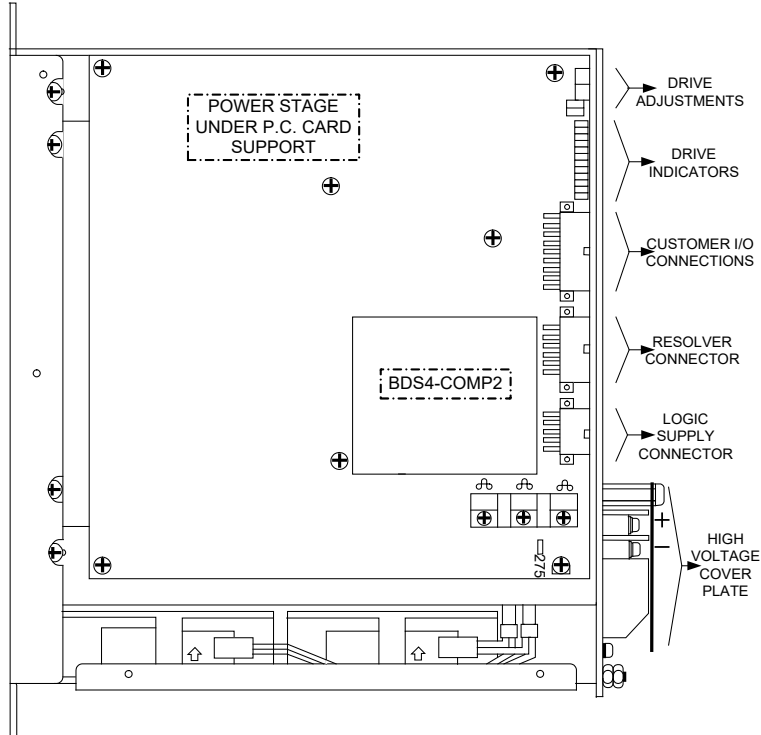

2.2 Typical Power Supply

2.2.1 Outline Dimensions

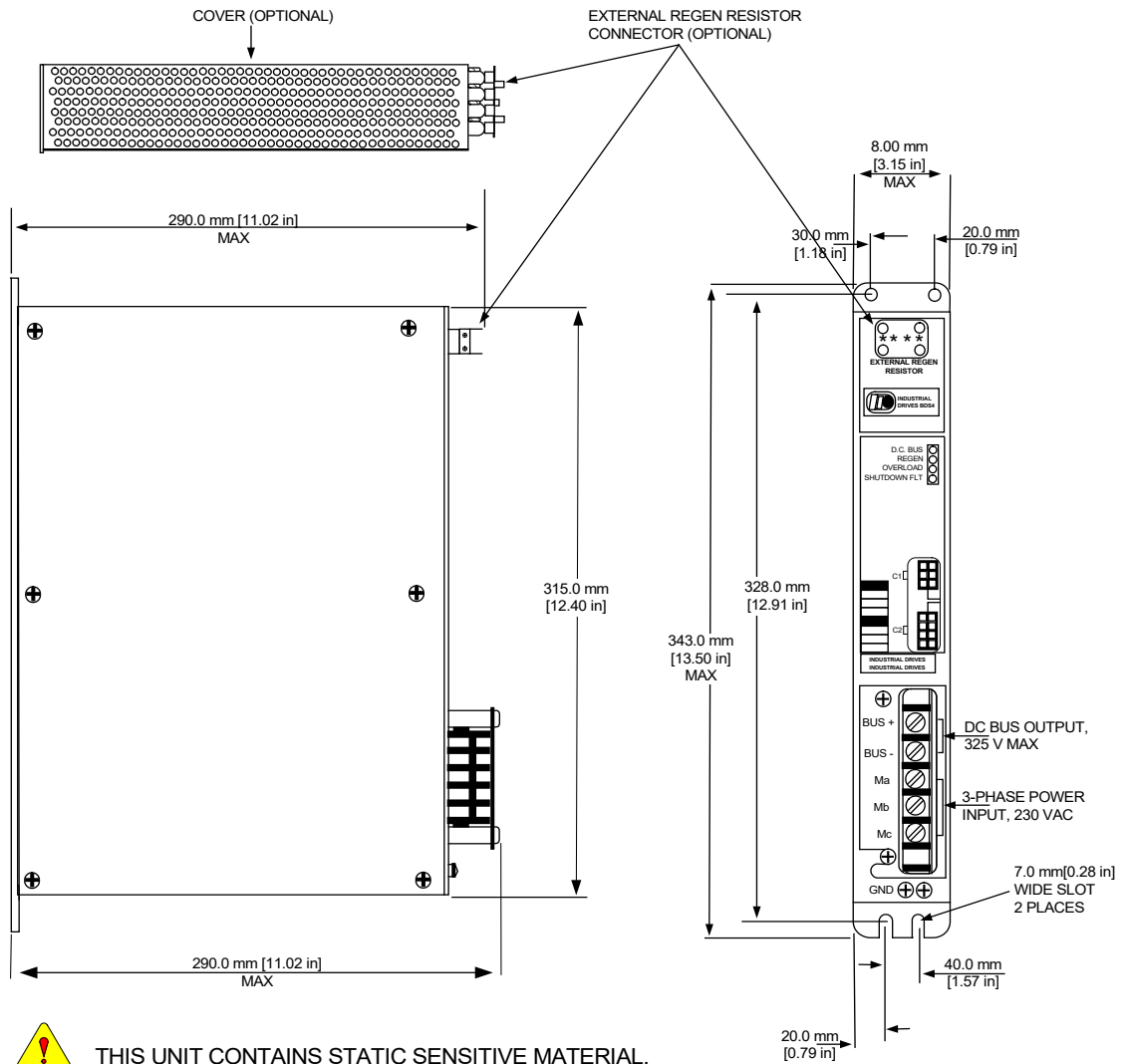

CAUTION THIS UNIT CONTAINS STATIC SENSITIVE MATERIAL. HANDLE ACCORDINGLY.

A-84385 - PRS4/5-12 & 20 Amp

2.2.2 Front View

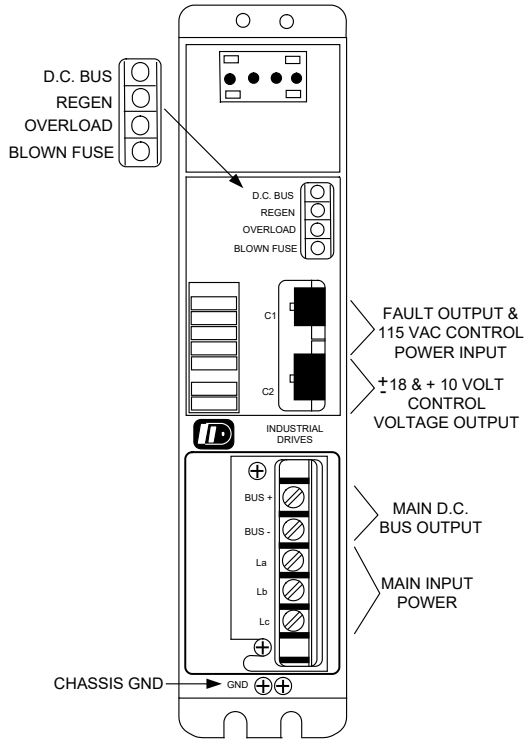

2.2.3 Side View

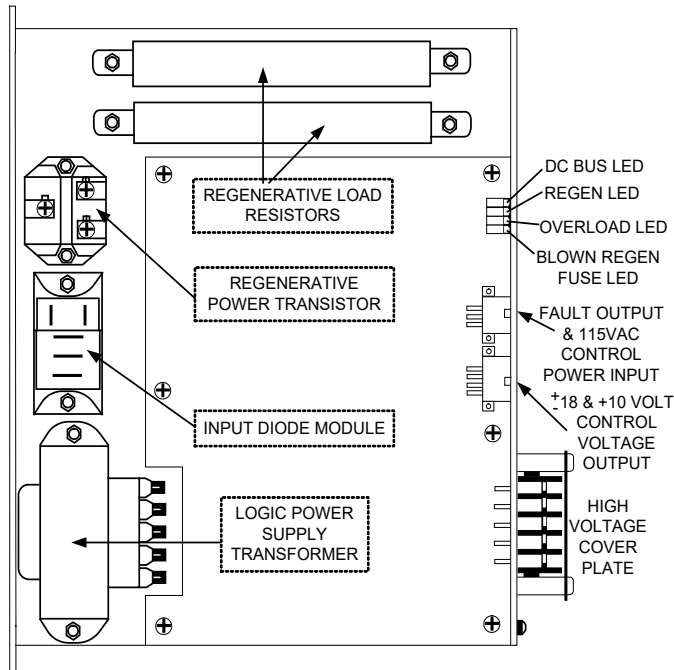

2.3 System Wiring

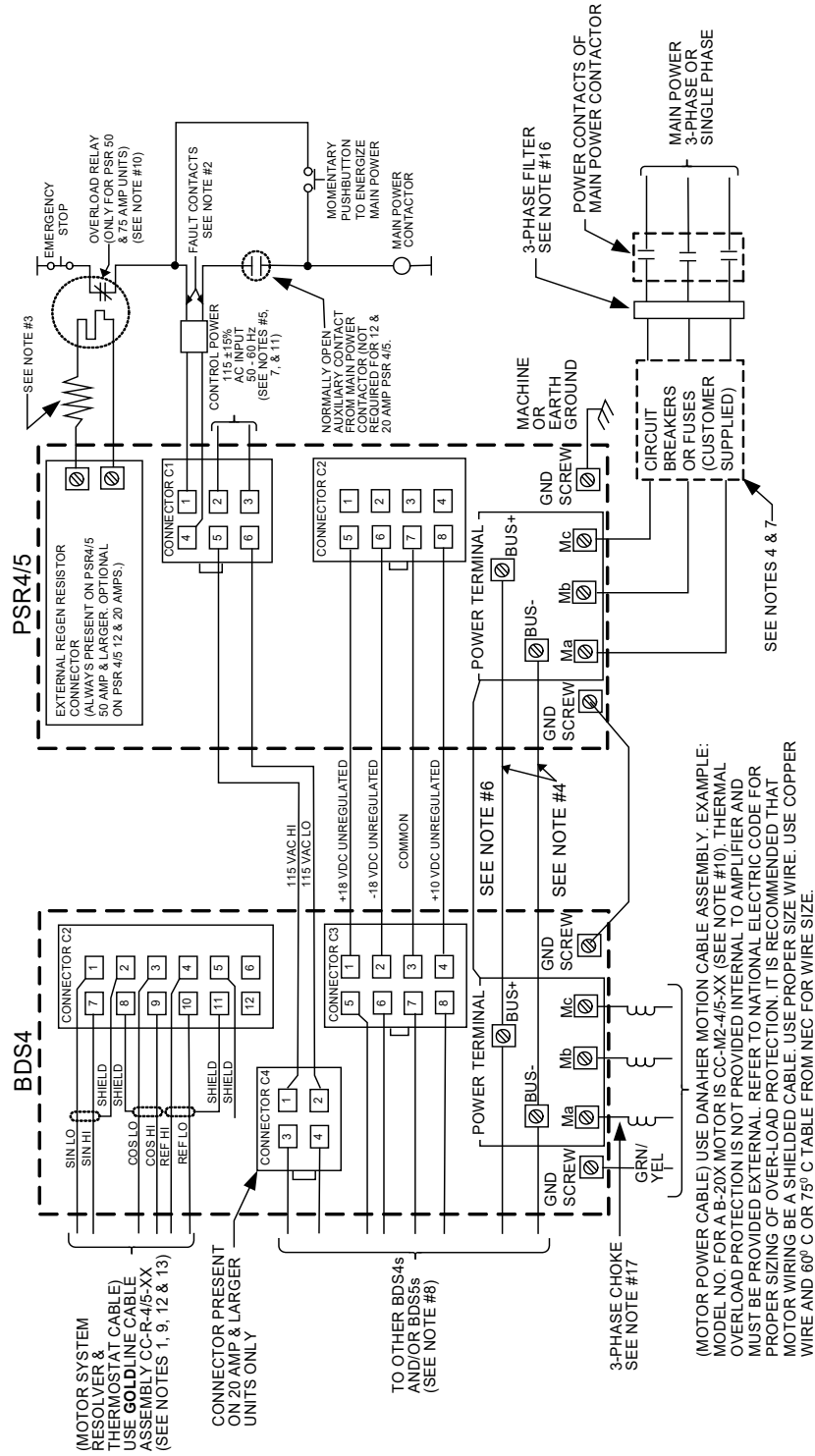

*Notes are on the following pages.

(ALL WIRES TO BE COPPER WITH MIN. TEMP. RATING OF 60° C)**⚠ WARNING**

The motor thermostat automatically resets when the motor cools. You are responsible for latching this signal to inhibit operation after a motor thermostat fault. Connect thermostat using twisted pair wire.

⚠ CAUTION

The PSR4/5 fault contacts (rated 115 VAC 1 amp) must be wired in series with the overload relay. On 12 & 20 amp PSR4/5s, this contact is normally open and closes within 250 ms after application of control and main power. This contact opens in fault conditions. On 50&75 amp PSR4/5s, this contact closes on application of control power and opens in fault conditions.

⚠ WARNING

Resistor is connected to high voltage. Ensure sufficient electrical clearance when mounting. Resistor may become very hot during operation. **Do not** mount near materials that are flammable or damaged by heat. Ventilation may be required. See wiring drawing for specific regen resistor kit. Each kit has different series/parallel resistor connections to obtain specific resistance and power rating.

NOTE

Wire sizes, breakers and fuses for PSR4/5:

- PSR4/5-X12 has a max main power input current of 12 A_{RMS}.
- PSR4/5-X20 has a max main power input current of 20 A_{RMS}.
- PSR4/5-X50 has a max main power input current of 50 A_{RMS}.
- PSR4/5-X75 has a max main power input current of 75 A_{RMS}.

The actual application may require less current. Use 600 VAC insulated wire and refer to local electrical codes for proper wire size for the currents listed above. Fuses for main power should be a U.L. rated time delay type, such as, buss FRN-R series.

The power BUS between a PSR4/5 and BOS4 should use the following wire gauge with 600 VAC insulation:

- PSR4/5-X12, 14 AWG (or larger) wire.
- PSR4/5-X20, 10 AWG wire.
- PSR4/5-X50, 8 AWG (or larger) wire.
- PSR4/5-X75, 8 AWG (or larger) wire.

NOTE

All signal and control wires must be 22-18 AWG wire. The crimp terminals for 22-18 AWG wire are supplied for use with BDS4 connectors C1, C2, C3, C4, option connector and PSR4/5 connectors C1 & C2, for 16 AWG wire use Molex #39-00-0078 terminals.

In the BDS4 3 amp thru 20 amp and the PSR4/5 12 amp and 20 amp, the screws in the power terminal blocks are captive. **DO NOT** attempt to remove them to use ring terminals. Use locking spring spade terminals such as Hollingsworth #XSS20954S or #SS20947SF for 16 AWG wire and #XSS20836 or #SS20832F for 12/10 AWG wire.

NOTE

All AC lines should be twisted cables.

NOTE

The total number of axes allowed, per PSR4/5, depends on the PSR4/5 model and the combination of BDS4s and/or BDS5s:

- PSR4/5-X12: a max of 4 BDS4's or 3 BDS5s.
- PSR4/5-X20: a max of 4 BDS4's or 3 BDS5s.
- PSR4/5-X50: a max of 6 BDS4's or 6 BDS5s.
- PSR4/5-X75: a max of 6 BDS4's or 6 BDS5s.

(If the BDS's are mixed, then the total number of axes that can be used would be the max given for the BDS5s.)

NOTE

XX in the cable number stands for cable length in meters. Cable length is available from 3 to 75 meters in increments of 3 meters.

NOTE

A thermal overload relay is supplied in the regen resistor kit for the 50 and 75 amp PSR4/5s. The thermal overload relay, included in the kit, was sized for your resistance and power rating. The output contacts of the relay must be wired to drop power to the main power contactor in a fault condition, as shown on sheet 1.

NOTE

Do not wire control power (PSR4/5 connector C1) through the main power contactor. This is so that control power will not be removed if PSR4/5 fault contacts open (this would turn **OFF** any fault LEDS).

NOTE

All shielded cables must have shield continuity for the full length of the cable.

NOTE

Resolver cable must be individually shielded pairs.

NOTE

Recommended torques for connection to terminal blocks and ground.

- BDS4/5-3 to 20 amp and PSR4/5-12 and 20 amp
 - Max torque per UL is 12 in/lb, external regen, main power and BUS connection.
 - Max torque 12 in/lb ground screw.
- BDS4/5-30 to 55 amp
 - Max torque 20 in/lb motor, BUS connection and ground stud
- PSR4/5-50 to 75 amp
 - Max torque 20 in/lb main power, BUS connection and ground stud
 - Max torque 12 in/lb external regen connection

For grounding to machine or earth ground. A screw lug should be attached to ground screw or stud. Recommended torque of 12 in/lb for ground screws and 20 in/lb for ground studs. May also refer to national electrical code (NEC) or UL standard 486B for recommended torques.

Thermal overload protection **DOES NOT** provide internal to amplifier and must be provided external. Refer to national electrical code for proper sizing of overload protection.

NOTE

Use a Corcom 5R1 single phase filter or equivalent (for CE requirements).

NOTE

Use a Shaffner three phase filter or equivalent

- Model No. 258-16/07 for PSR4/5A-112 & 212.
- Model No. 258-30/77 for PSR4/5A-120 & 220.
- Model No. 258-55/07 for PSR4/5A-250.
- Model No. 258-75/34 for PSR4/5A-275.
- For CE requirements.

NOTE

Use a Shaffner three phase choke or equivalent.

- Model No. RD 7137-6-12m0 or RD 7137-36-0m5 for BDS4A-103, 203, 106 & 206.
- Model No. RD 7137-10-6m6 or RD 7137-36-0m5 for BDS4A-110 & 210
- Model No. RD 7137-25-1m3 or RD 7137-36-0m5 for BDS4A-120 & 220
- Model No. RD 7137-36-12m0 for BDS4A-230.
- Model No. RD 7137-64-12m0 BDS4A-240 & 255.
- (For CE requirements)

NOTE

Suitable for use on circuit capable of delivering not more than 5000 symmetrical A_{RMS} , 240 volts max.

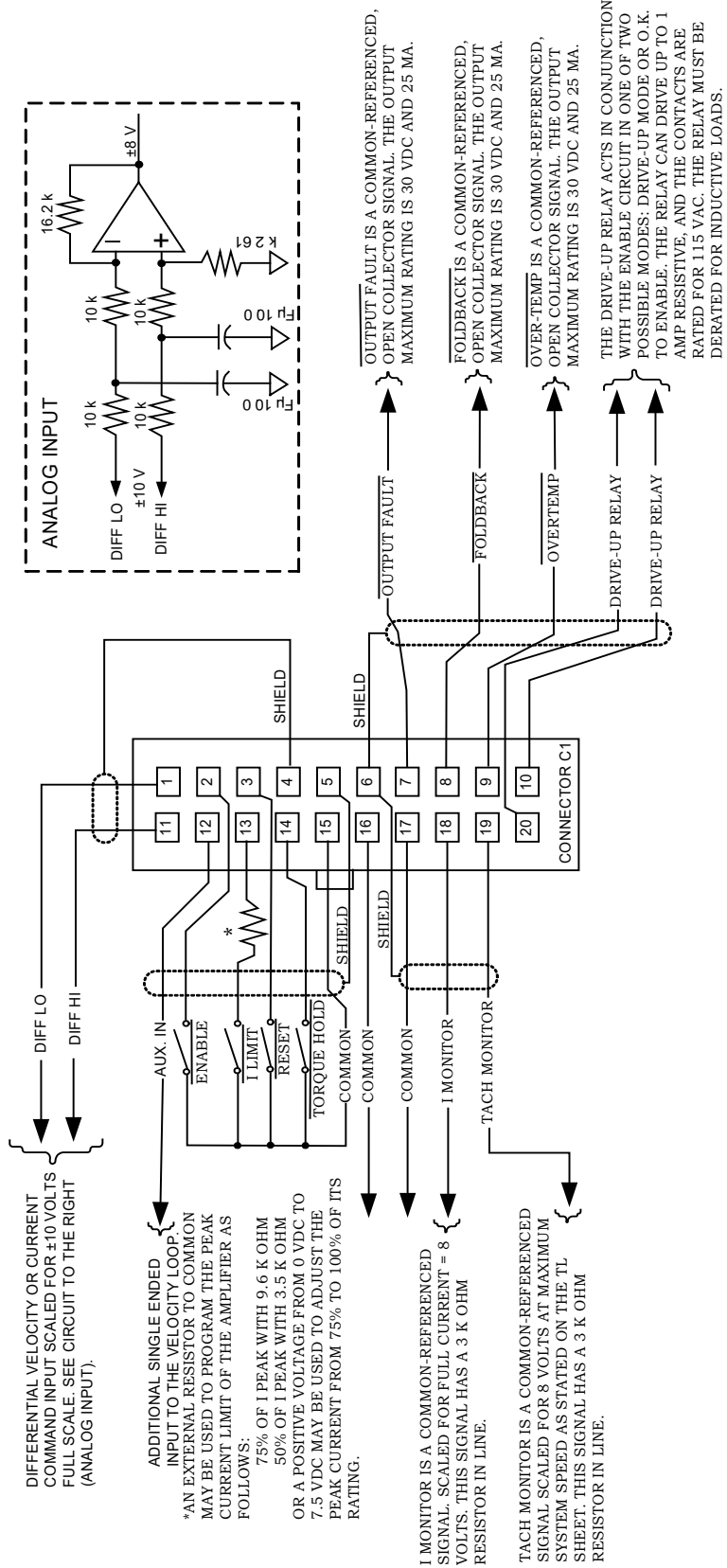

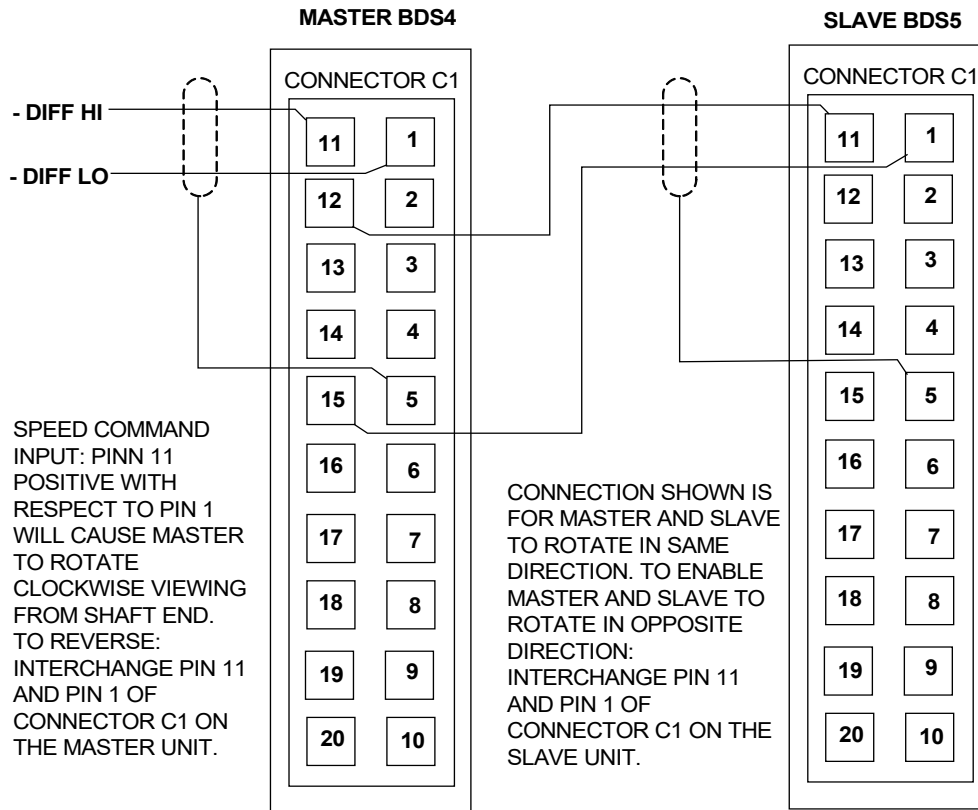

System Setup

1. The master unit requires a master (M) type compensation card – designated (i.e., BDS4-230J/SOSA2M). The slave requires a slave (S) type compensation card designated (i.e., BDS4-230J/XOXA2S).
2. For proper load sharing between the master and slave units, the following adjustment must be made on the slave unit (the stability and command scale pots now function as torque gain adjustments):
 - Adjust the stability pot fully counter-clockwise.
 - Adjust the command scale pot fully clockwise.
 - Adjust the current limit pot fully clockwise.
 - Under load conditions, the load sharing may be improved slightly by comparing each unit's current monitor signal:
 - To increase load on the slave unit, adjust its stability pot clockwise
 - To decrease load on the slave unit, adjust its command scale pot counter-clockwise.
3. Master/slave operation is incompatible with brush tach systems.

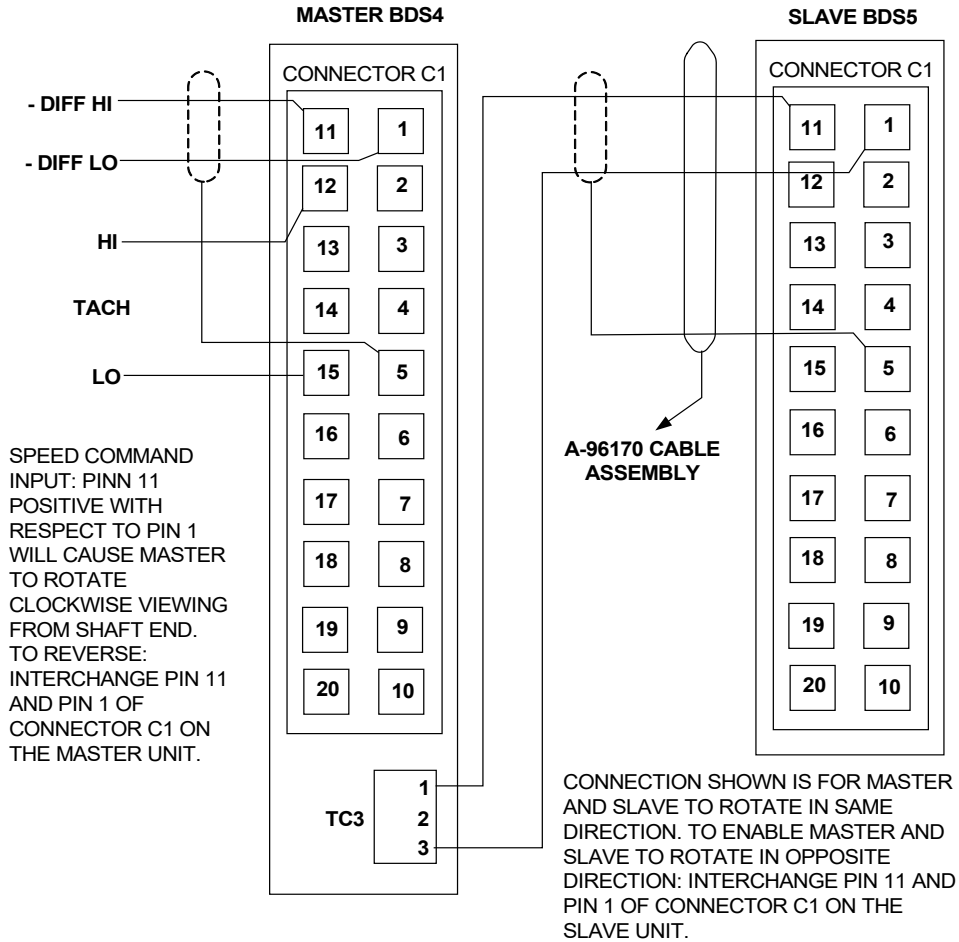

System Setup

1. The master unit requires a master (M) type compensation card – designated (i.e. BDS4-230J/X0XA2M). The slave requires a slave(s) type compensation card – designated (i.e. BDS4-230J/X0XA2S).
2. For proper load sharing between the master and slave units, the following adjustment must be made on the slave unit (the stability and command scale pots now function as torque gain adjustments):
 - Adjust the stability pot fully counter-clockwise.
 - Adjust the command scale pot fully clockwise
 - Adjust the current limit pot fully clockwise
 - Under load conditions, the load sharing may be improved slightly by comparing each unit's current monitor signal:
 - To increase load on the slave unit, adjust its stability pot clockwise
 - To decrease load on the slave unit, adjust its command scale pot counter-clockwise.

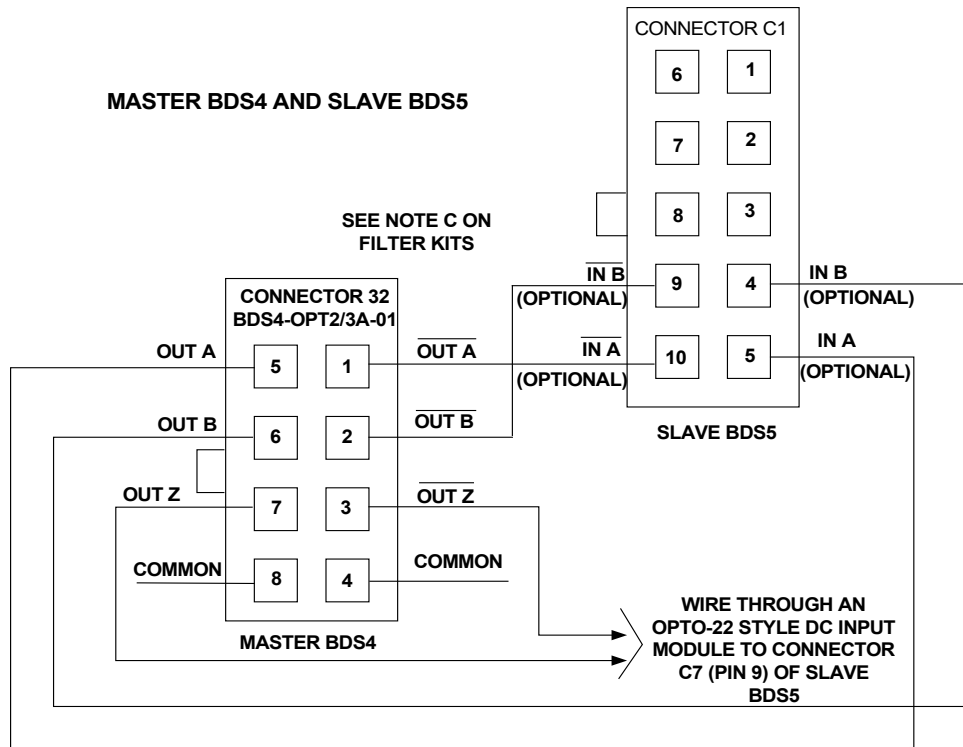

NOTE

The commons of master BDS4 and slave BDS5 must be connected. This is accomplished through connector C3 in the BDS4 and connector C4 in the BDS5 if they share one PSR4/5.

NOTE

If the BDS5 uses the optional analog input card (BDS5-OPT1), the optional encoder inputs in connector C1 are not allowed.

NOTE

The filter kit uses a Ferrishield Sleeve snap model no. SS3382036 or equivalent

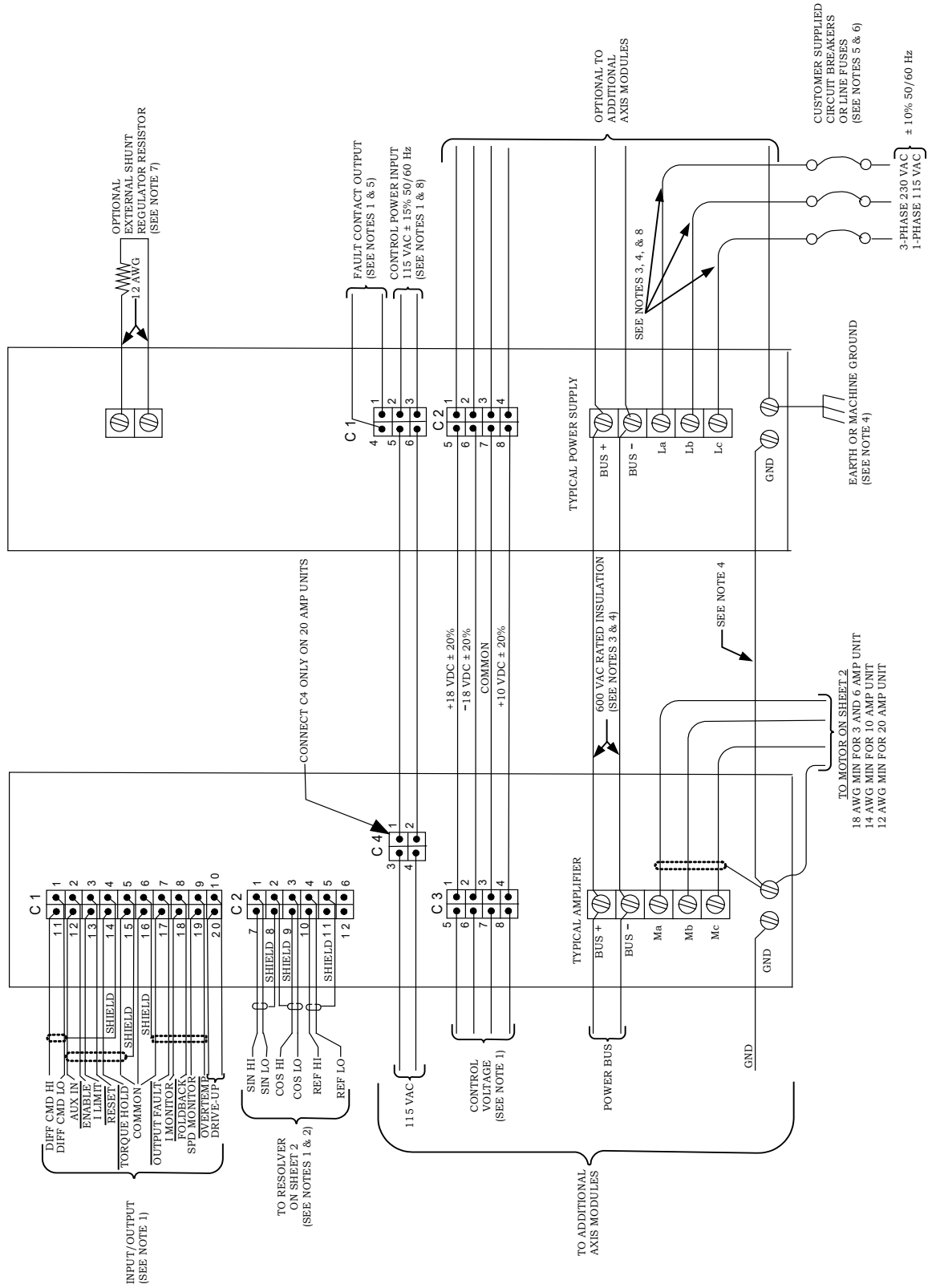

*Notes are shown on the next page.

Notes for previous diagram:

1. All signal and control wire to be 22-18 AWG wire. If 16 AWG is desired, then use Molex #39-00-0078 crimp pins (not supplied) instead of the parts supplied.
2. Resolver must be wired with (3) sets of 2-conductor shielded pairs as shown. Thermostat wiring to be twisted pair.
3. **Caution**, the screws in the power terminal blocks are captive. Do not attempt to remove them for using ring terminals. Use locking type spring spade terminals such as Hollingsworth #XSS20954S or #SS20947SF for 16/14 AWG wire and #XSS20836 or #SS20832F for 12/10 AWG wire.
4. Wire gauge dependent on application: For total axis currents less than 9-amperes: 16 AWG may be used. For total axis currents greater than 20-amperes: 10 AWG must be used.
5. The power supply fault contact (rated 115 VAC 1 amp) should be wired to drop main 3-phase power (La, Lb, Lc) in fault conditions. (This contact is normally open, closed on power-up (approximately 0.250 ms) and opens in fault conditions.)
6. Fuse or circuit breaker sizing dependent on application.
 - PSR4 Recommended Fuse
 - 12 amp Buss #FAN-A-12 or equivalent
 - 20 amp Buss #FAN-A-20 or equivalent
7. Resistor must be mounted away from any flammable material. A 400 VDC potential is present (electrical isolation should be maintained for this voltage rating).
8. All AC lines should be twisted cables.

2.4 Typical Motor Wiring

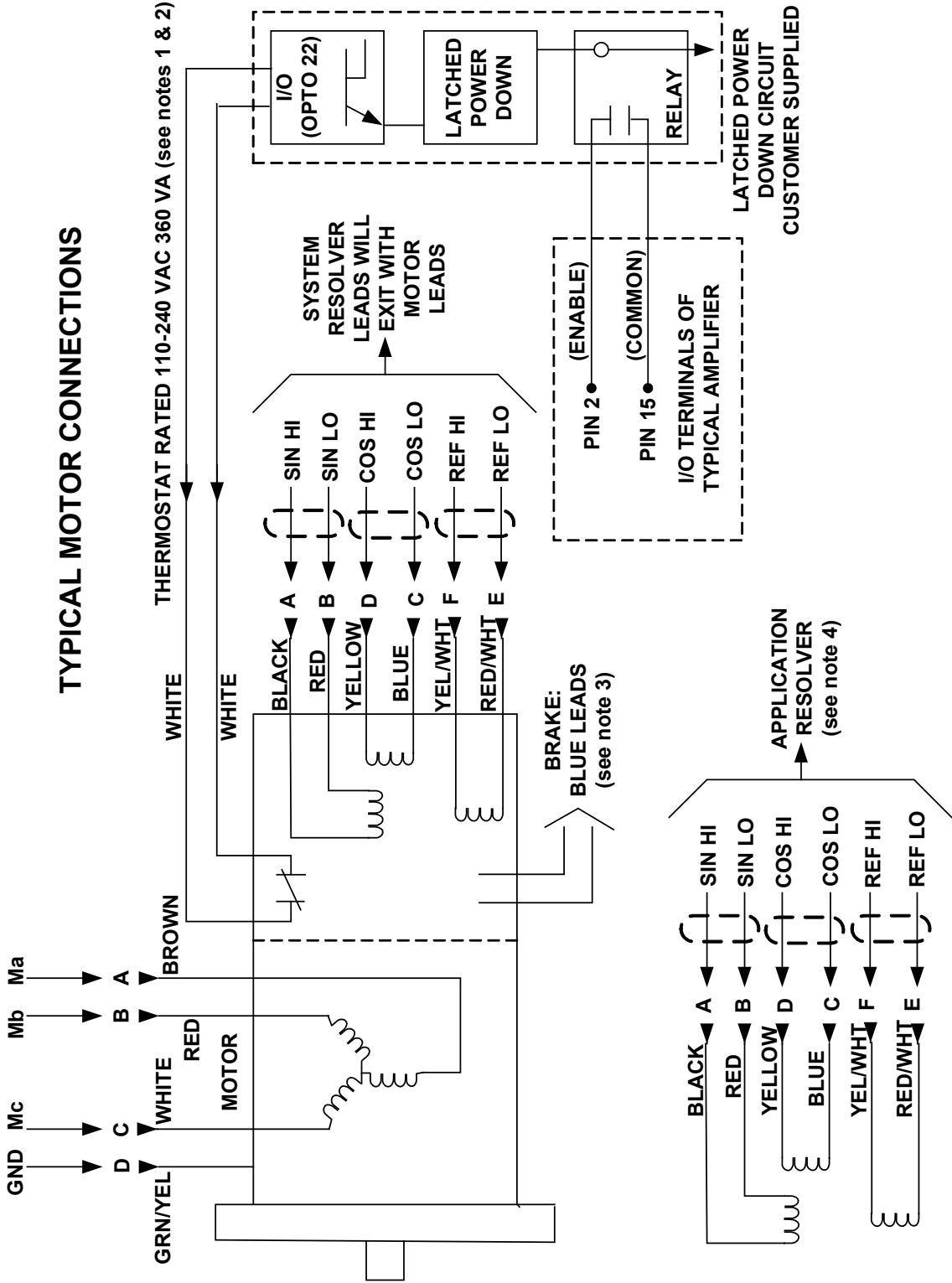

Notes are found on following page.

Notes for previous diagram:

1. The motor thermostat is an automatic resetting device and should be connected into a latched (lock-out) power down type circuit.
2. Thermostat to be wired with twisted pair.
3. The brake should be energized before switching the motor on and while it is in operation. For proper operation an electrical interlock circuit should be employed to ensure that the brake is not engaged while the motor is energized.

Model	Holding VDC	Holding ADC
EB-40X-X-XX-B2	90	0.26
EB-40X-X-XX-B3	24	0.88

4. Application resolver leads will exit at a different location than system resolver leads.

2.5 Grounding

Ground the motor at either the amplifier motor terminal block or at the main ground point. Connect shielded cables at one end only.

2.6 Inputs

The drive-up contact closure (internal) is provided at pins 10 and 20. When this internal contact is closed, it indicates to the outside world (software) that the typical amplifier is ready to operate. When open, it is an indication that it is in inhibit mode. The contact is rated at 115 VAC at 2 amps.

⚠ CAUTION

The motor is provided with two, normally-closed thermostat reset devices connected in series. They are auto-resetting devices intended to shut off power from the amplifier to limit the surface temperature of the motor and prevent ignition in hazardous atmospheres.

The remote Inhibit disables the amplifier without removing the main power. When a contact is closed between pins 2 and 15 (D-common), the amplifier is placed in ready to operate mode. These pins (2 & 15) are connected through the latched power down circuit to the motor thermostat. The motor thermostat is an automatic resetting device that shuts down the power from the controller should an over-temperature condition occur in the motor windings. Connect the thermostat to a latched (locked-out) power down circuit that requires a manual reset. This prevents inadvertent restarting of the motor when it cools down below the thermostats set value.

2.7 Preliminary Checks

Once the typical amplifier system has been installed and wired in, follow the steps below to ensure proper **operation before the main power is applied**.

2.7.1 Checking AC Input Voltage

Open the circuit breaker or remove the fuses in the secondary of the large 3-phase isolation transformer.

Apply power. With an AC voltmeter, check the 3-phase secondary line-to-line voltage. The voltage should be approximately $230 V_{RMS} \pm 10\%$.

Remove power. Close the circuit breaker or replace the fuses in the secondary of the large 3-phase isolation transformer.

2.7.2 Checking Power Supply DC Output Voltage

Do not apply the 115 VAC. Apply power to the large 3-phase transformer only. With a DC voltmeter, monitor the 325 VDC bus bars of the power supply and amplifier units. The voltage from the power supply should be approximately $\pm 325 VDC \pm 10\%$. Remove power.

To Adjust the System Resolver to zero:

⚠ CAUTION Do not remove the cover while the motor is in a hazardous location.

1. Remove power.
2. Remove the motor end cover.
3. Loosen, but do not remove the resolver servo clamp screws.
4. Rotate the outer member of the resolver as needed for adjustment.
5. Replace and cover. All bolts must be tightened securely before applying power to the motor or resolver.

2.7.3 Zero System Resolver

1. Do not remove the cover while the motor is in a hazardous location.
2. Remove power.
3. Remove the motor and cover.
4. Loosen, but do not remove the resolver servo clamp screws.
5. Rotate the outer member of the resolver as needed for adjustment.
6. Replace end cover. All bolts must be tightened securely before applying power to the motor or resolver.

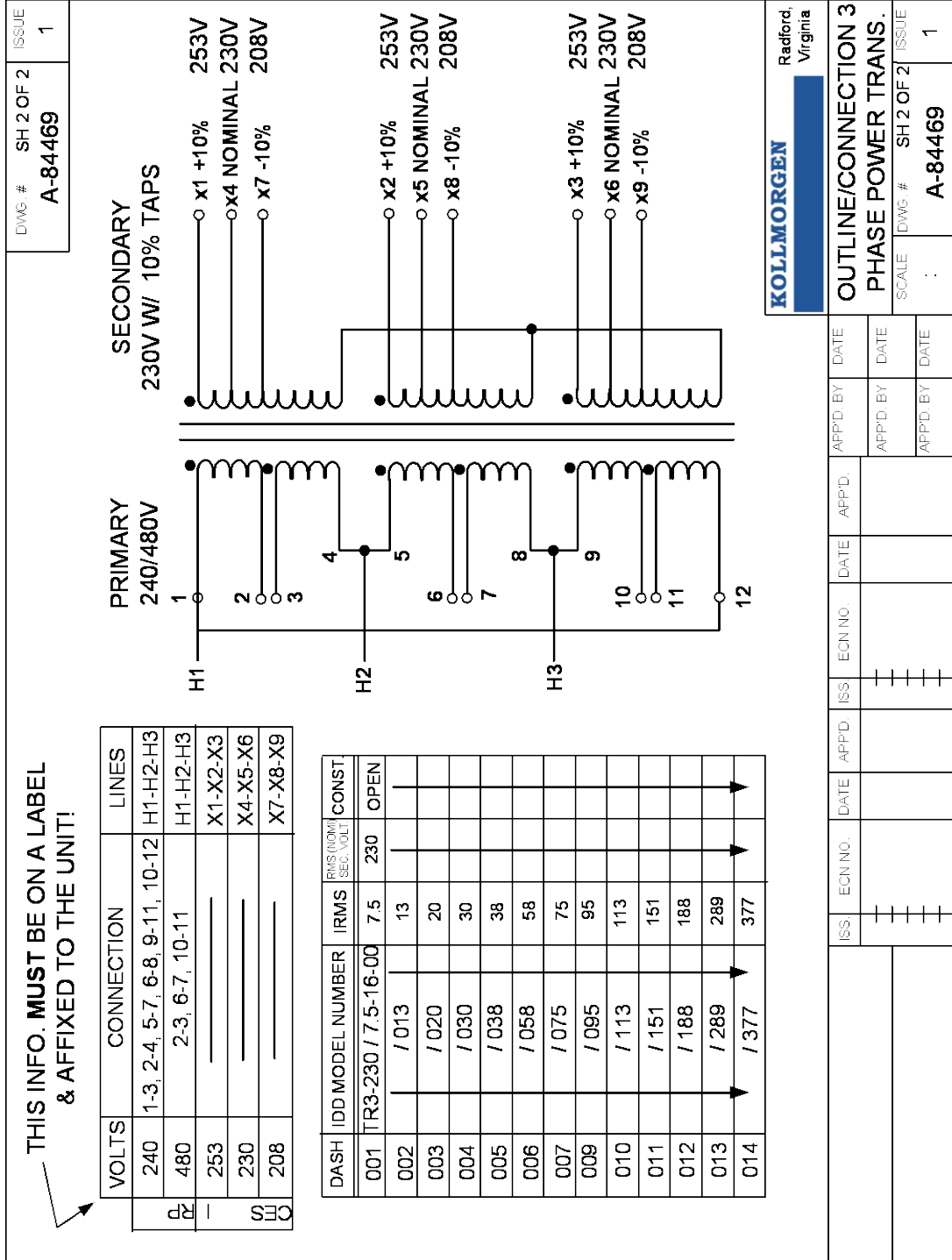

KOLLMORGEN

Radford,
Virginia

**OUTLINE/CONNECTION 3
PHASE POWER TRANS.**

SCALE : DWG. # SH 2 OF 2 ISSUE :
: : **A-84469** : : 1

3. MOTOR DATA PACKAGE

This product's features and benefits are:

- UL-listed explosion-proof for Class I, Groups C & D hazardous locations
- Neodymium-Iron-Boron magnets
- Aluminum end bells
- Frameless, shaft-mounted resolver
- Rugged Construction

3.1 Model Number System

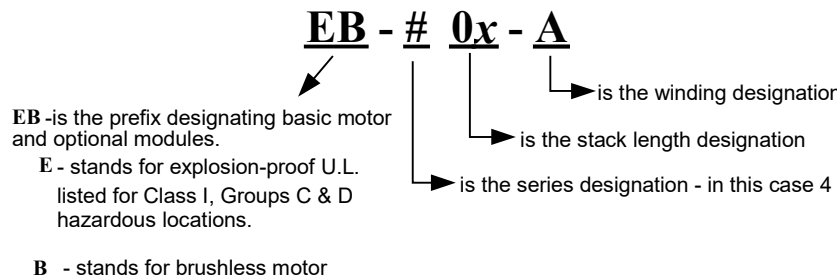

3.2 Outline Drawing

3.2.1 EB-40X-X-11

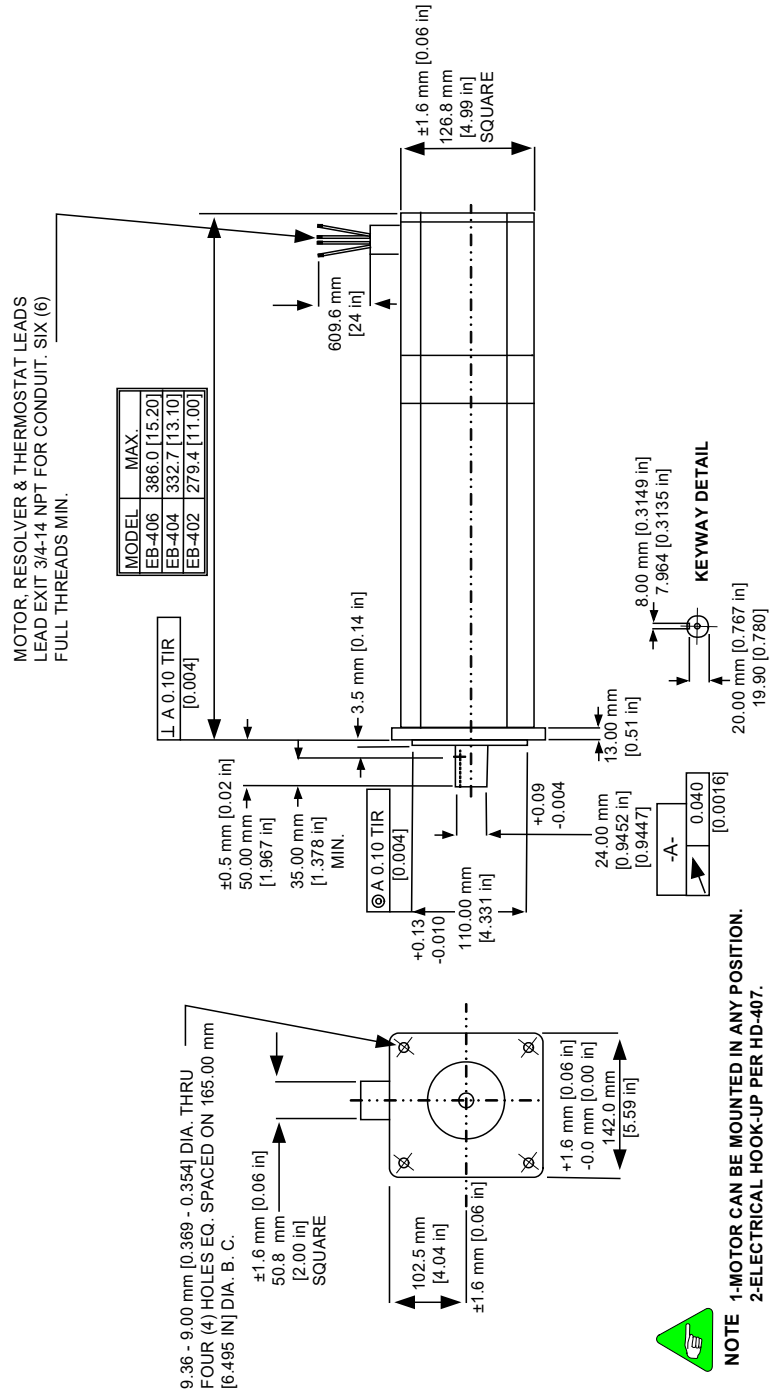

A-62767 & A62637

3.2.2 EB-40X-X-11-B()R

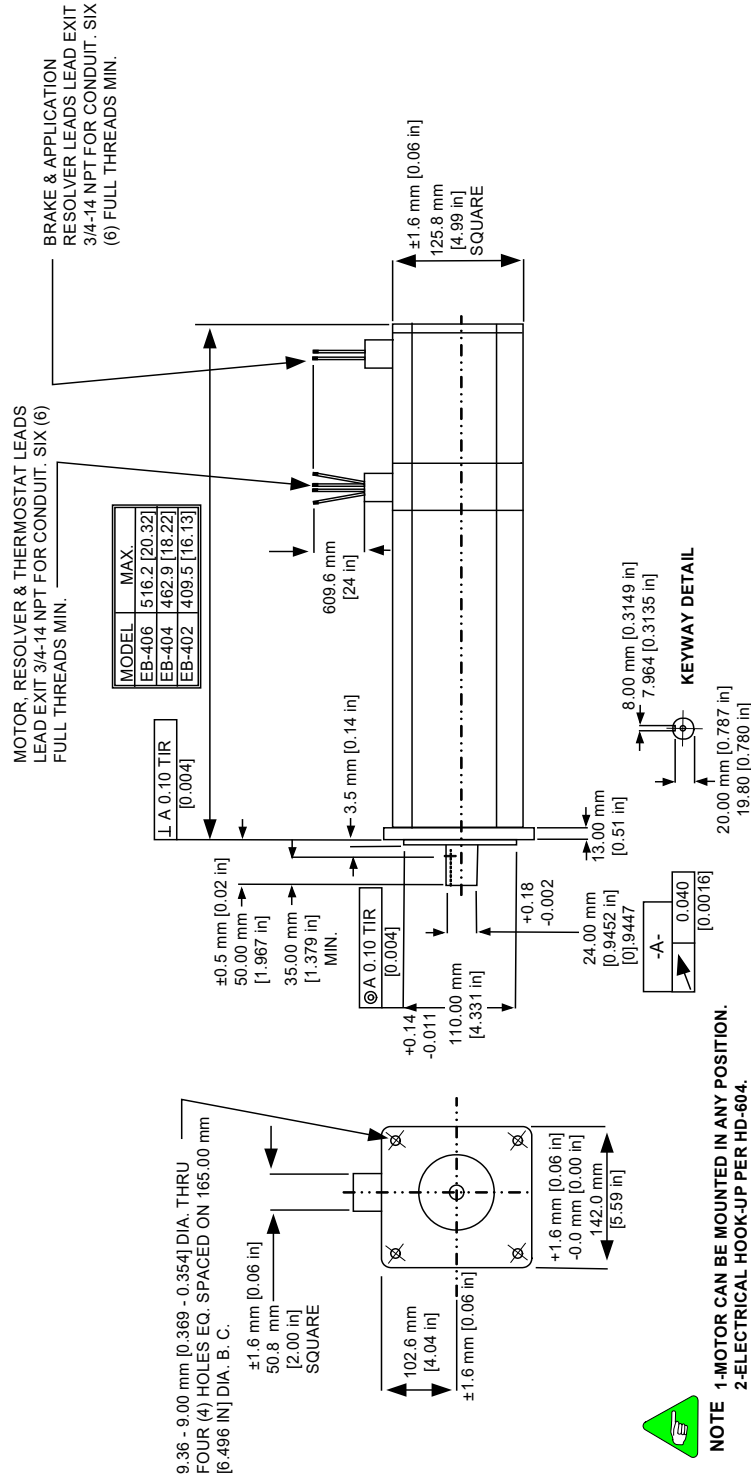

A-62637

3.3 EB-402

3.3.1 Specifications CD-27010

Specification	Tol	Symbol	Units	A	B	C	
*Continuous Torque (stall) at 40° C Ambient	Nom.	T _C	lb-ft	5.0	5.2	4.8	
			N-m	6.8	7.0	6.5	
Cont. Line Current	Nom.	I _C	A _{RMS}	3.0	6.4	9.8	
†Max. Speed	Nom.	N max.	rpm	1500	3000	5000	
*Peak Torque	Nom.	T _P	lb-ft	14.6	14.6	14.6	
			N-m	19.8	19.8	19.8	
Peak Line Current	Nom.	I _P	A _{RMS}	9.3	18.8	31.3	
129.2†Theoretical Acceleration	Nom.	α _m	rad/sec ²	61344	61344	61344	
†Horsepower	Rated	H _P rtd	HP	1.3	2.9	3.8	
†Speed	Rated	N rtd	rpm	1500	3000	5000	
†Torque	Rated	T rtd	lb-ft	4.5	5.0	4.0	
			N-m	6.1	6.8	5.4	
Volts (line to line)	Rated	V rtd	V _{RMS}	230	230	230	
*Torque Sensitivity	± 10%	K _T	lb-ft / A _{RMS}	1.660	0.820	0.490	
			N-m / A _{RMS}	2.52	1.11	0.66	
Back EMF (line-to-line)	± 10%	K _B	V/krpm	136.1	67.2	40.2	
Max. line-to-line volts	Max.	V max	V _{RMS}	250	250	250	
DC Res at 25° C (line-to-line)	± 10%	R _M	ohms	10.54	2.60	0.97	
Inductance (line-to-line)	± 30%	L _M	mH	220	50	21	
Time Constant at 25° C	Mech.	Nom.	T _M	ms	1.00	1.02	1.06
	Elec.	Nom.	T _E	ms	20.9	19.2	21.6
System Performance Curve				26626	26627	26688	

*At ultimate winding temperature for ambient data multiply by 1.06

†	Symbol	Units	Value
Rotor Inertia	J_M	lb ft sec ²	0.000238
		kg m ²	0.000323
Weight	Wt	lb	18.5
		kg (f)	8.4
Static Friction	T_F	lb-ft	0.18
		N-m	0.24
Thermal Time Constant Peak	TCTP	Minutes	6
Viscous Damping ∞Z Source	F_1	lb-ft/krpm	0.011
		N-m/krpm	0.015

† If brush type tach is used, these parameters may be affected. Consult the factory.

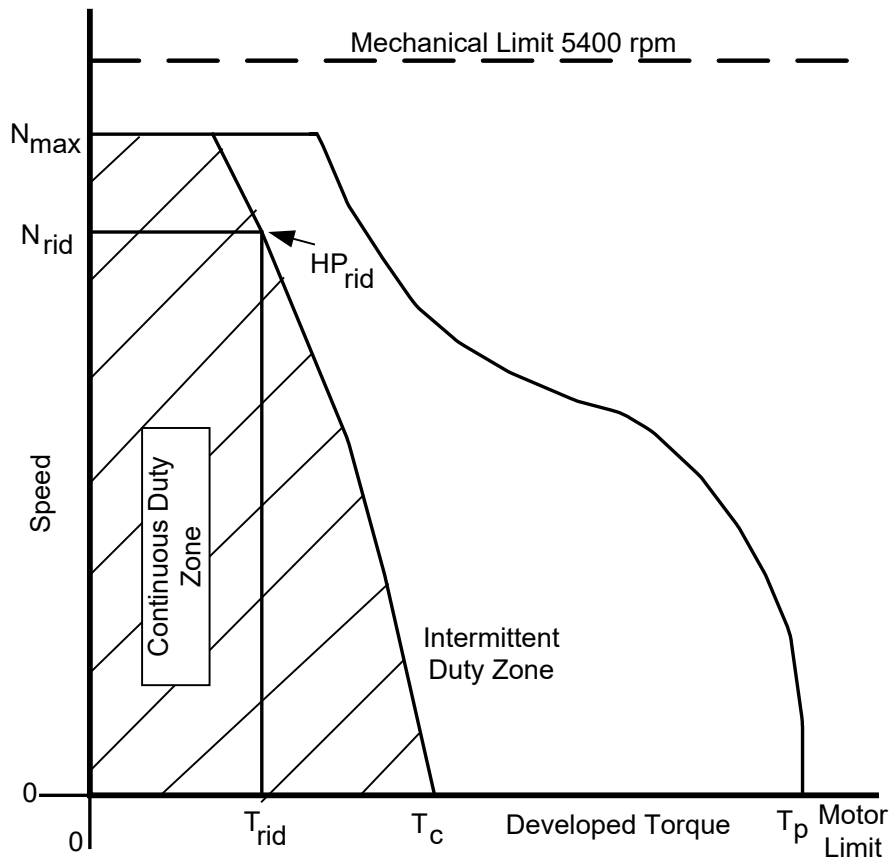

3.3.2 Performance Curves

3.3.2.1 EB-402-A PC 26626

NOTE

Do not operate this motor outside the parameters shown on this performance curve.

Motor EB-402-A
 Drive BDS4-230H
 Test T3-1451

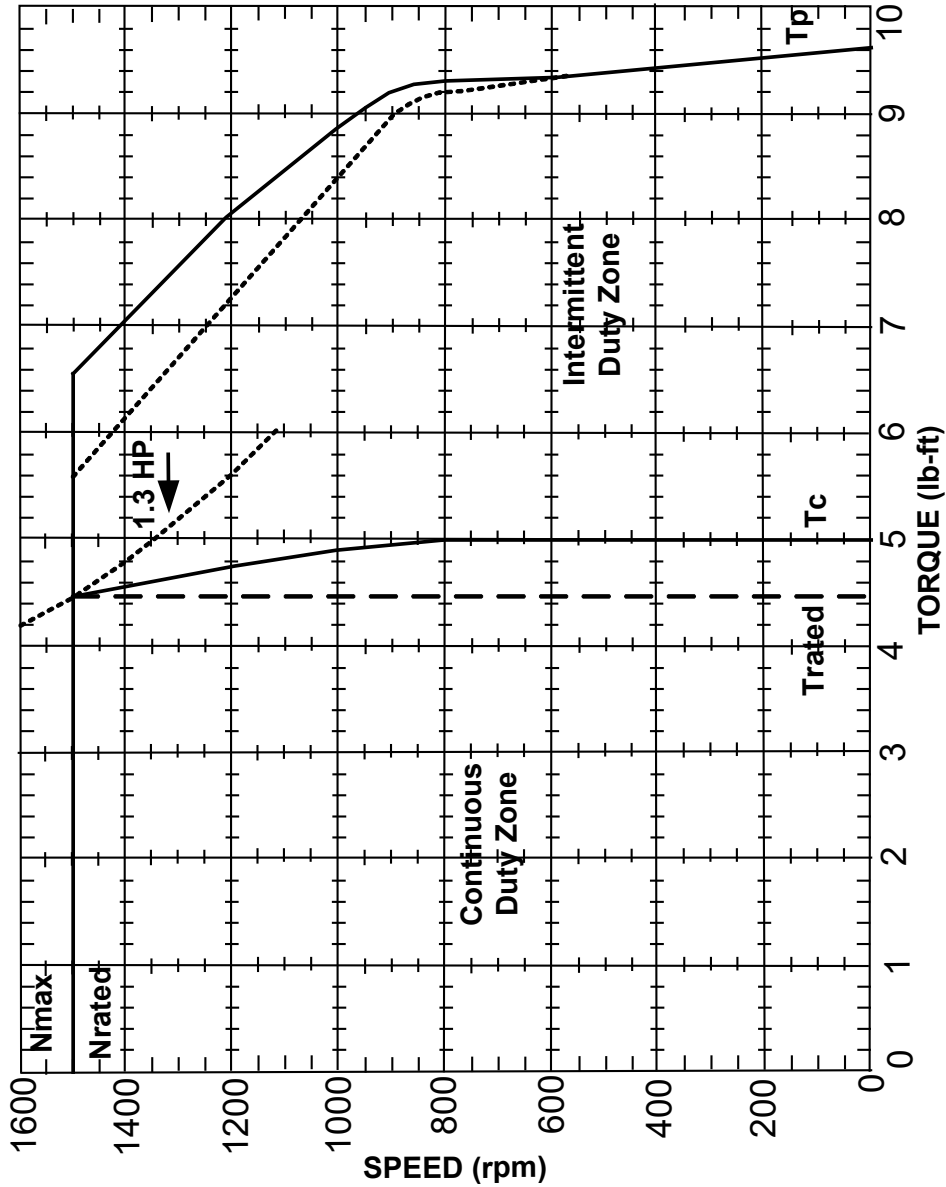

3.3.2.2 EB-402-B PC 26627

NOTE

Do not operate this motor outside the parameters shown on this performance curve.

Motor EB-402-B
 Drive BDS4-206H
 Test T3-1411

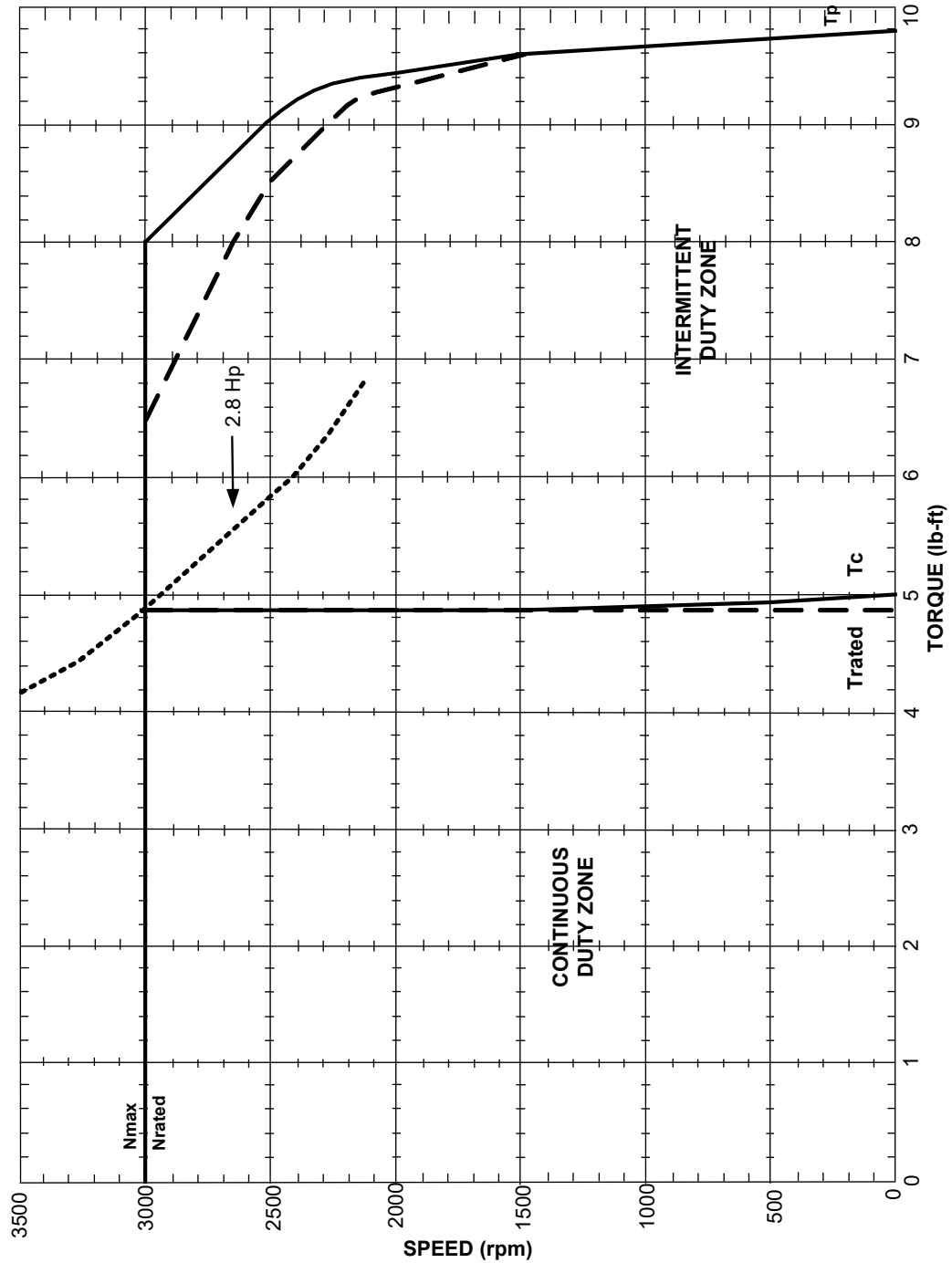

3.3.2.3 EB-402-C PC 26688

NOTE

Do not operate this motor outside the parameters shown on this performance curve.

Motor EB-402-C
 Drive BDS4-210H
 Test T3-1409

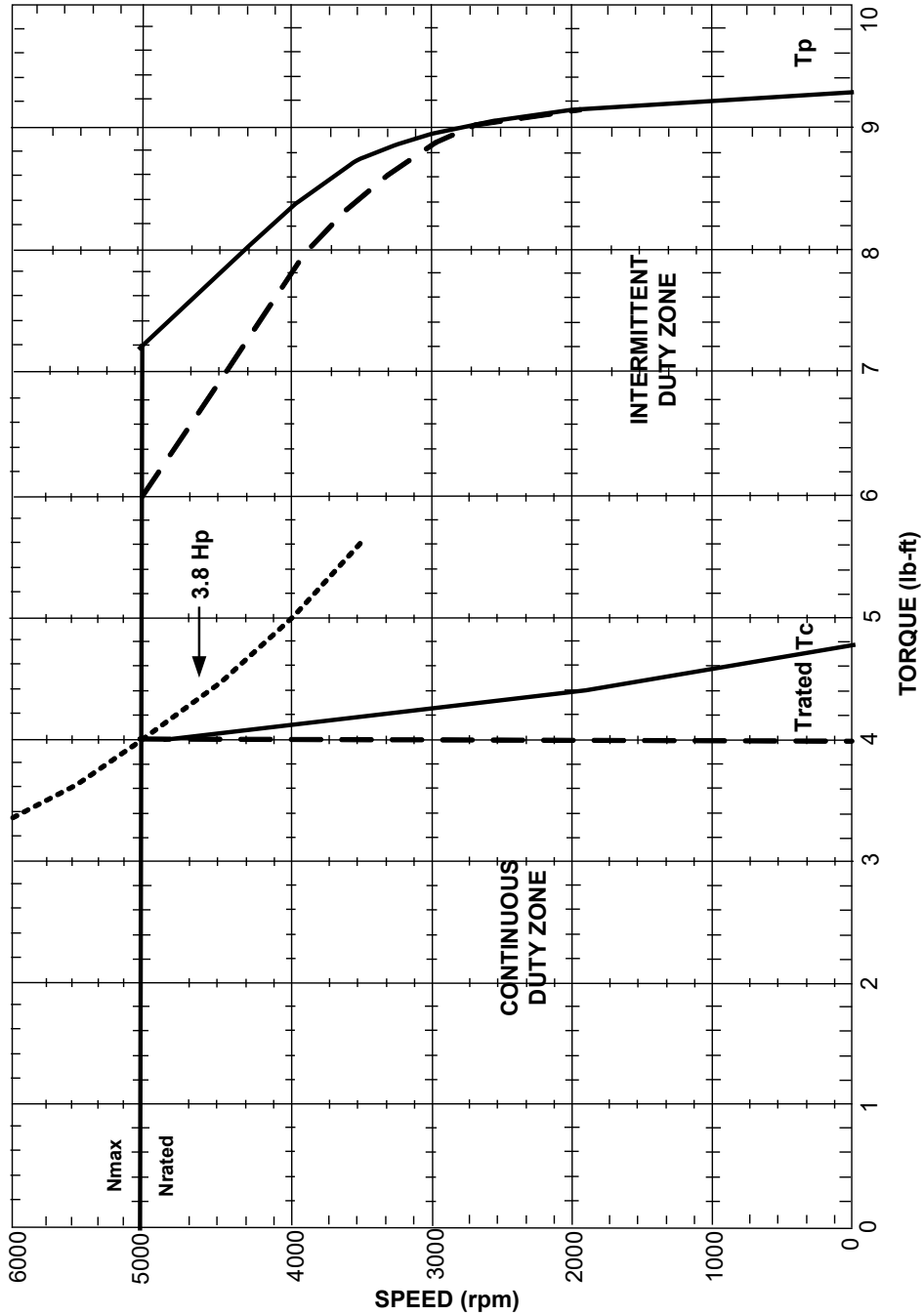

3.4 EB-404

3.4.1 Specifications CD 27011

Specification	Tol	Symbol	Units	A	B	C	D	
*Continuous Torque (stall) at 40° C Ambient	Nom.	T _C	lb-ft	9.6	9.8	9.7	9.7	
			N-m	13.0	13.3	13.1	13.1	
Cont. Line Current	Nom.	I _C	A _{RMS}	6.0	9.9	19.8	15.0	
†Max. Speed	Nom.	N max.	rpm	1500	2500	5000	3700	
*Peak Torque	Nom.	T _P	lb-ft	26.5	27.0	26.0	27.6	
			N-m	35.9	36.6	35.3	37.5	
Peak Line Current	Nom.	I _P	A _{RMS}	16.4	28.8	55.9	45	
129.2†Theoretical Acceleration	Nom.	α _m	rad/sec ²	54752	55785	53719	57025	
†Horsepower	Rated	H _P rtd	H _P	2.7	4.5	7.3	6.0	
†Speed	Rated	N rtd	rpm	1500	2500	5000	37000	
†Torque	Rated	T rtd	lb-ft	9.6	9.4	7.7	3.5	
			N-m	13.0	12.7	10.4	11.5	
Volts (line to line)	Rated	V rtd	V _{RMS}	230	230	230	230	
*Torque Sensitivity	± 10%	K _T	lb-ft / A _{RMS}	1.70	0.99	0.49	0.647	
			N-m / A _{RMS}	2.31	1.34	0.66	0.877	
Back EMF (line-to-line)	± 10%	K _B	V/krpm	139.4	81.2	40.2	53.0	
Max. line-to-line volts	Max.	V max	V _{RMS}	250	250	250	250	
DC Res at 25° C (line-to-line)	± 10%	R _M	ohms	4.10	1.32	0.34	0.63	
Inductance (line-to-line)	± 30%	L _M	mH	102	33.5	8.4	15.0	
Time Constant at 25° C	Mech.	Nom.	T _M	ms	0.725	0.688	0.723	0.806
	Elec.	Nom.	T _E	ms	24.9	25.4	24.7	23.3
System Performance Curve				26628	26629	26630	26796	

*At ultimate winding temperature for ambient data multiply by 1.06

†	Symbol	Units	Value
Rotor Inertia	J_M	lb ft sec ²	0.000484
		kg m ²	0.000656
Weight	Wt	lb	27.5
		kg (f)	12.5
Static Friction	T_F	lb-ft	0.19
		N-m	0.26
Thermal Time Constant Peak	TCTP	Minutes	9
Viscous Damping ∞Z Source	F_1	lb-ft/krpm	0.013
		N-m/krpm	0.018

† If brush type tach is used, these parameters may be affected. Consult the factory.

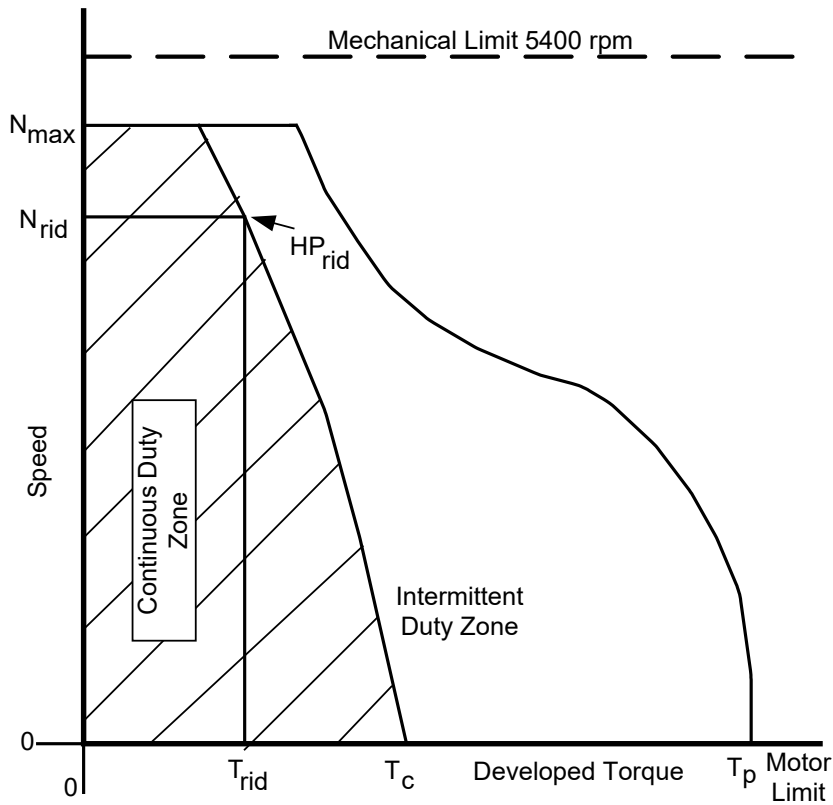

3.4.2 Performance Curves

3.4.2.1 EB-404-A PC 26628

NOTE Do not operate this motor outside the parameters shown on this performance curve.

Motor EB-404-A
 Drive BDS4-206H
 Test T3-1364

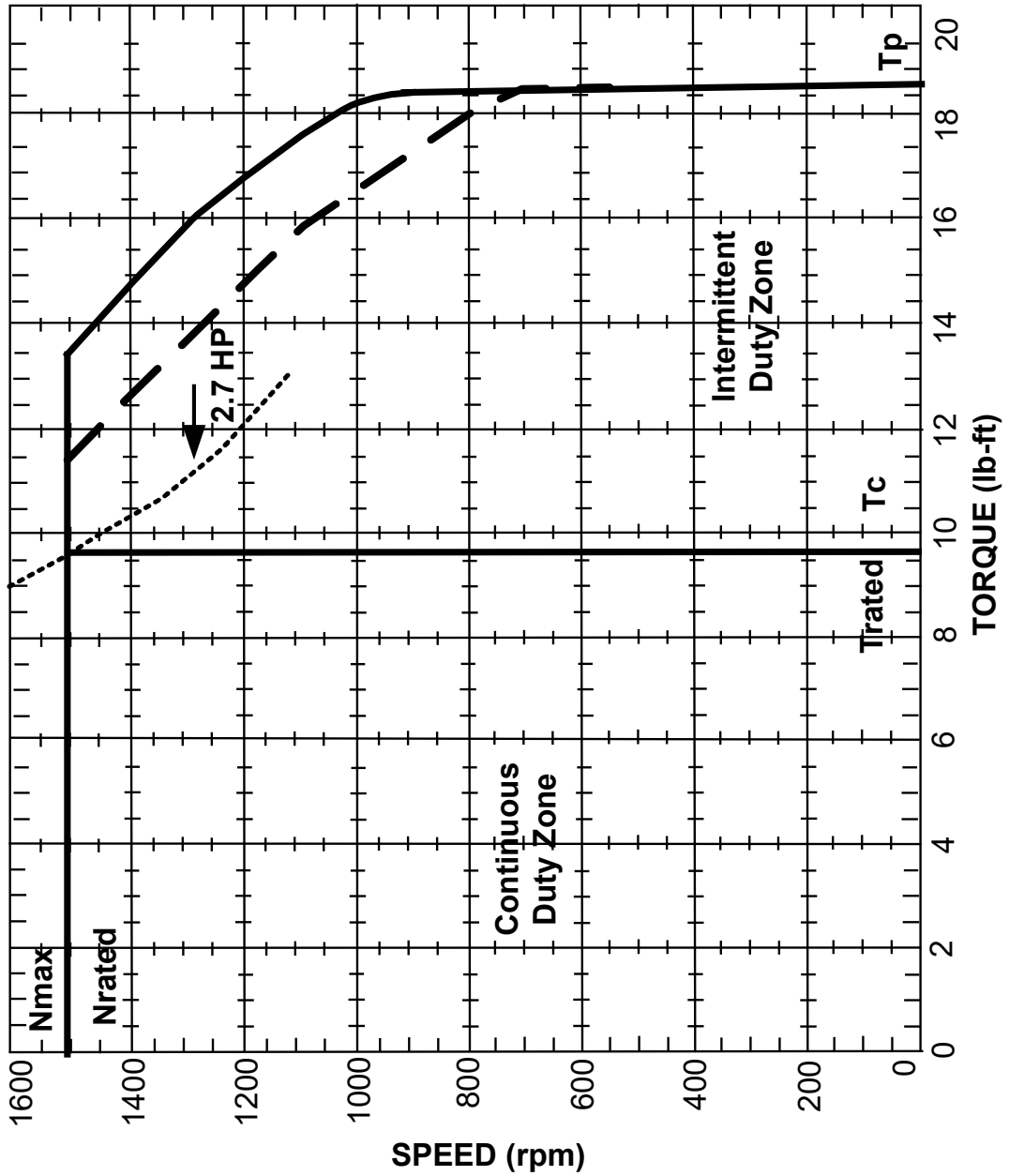

3.4.2.2 EB-404-B PC 26629

NOTE

Do not operate this motor outside the parameters shown on this performance curve.

Motor EB-404-B
 Drive BDS4-210H
 Test T3-1408

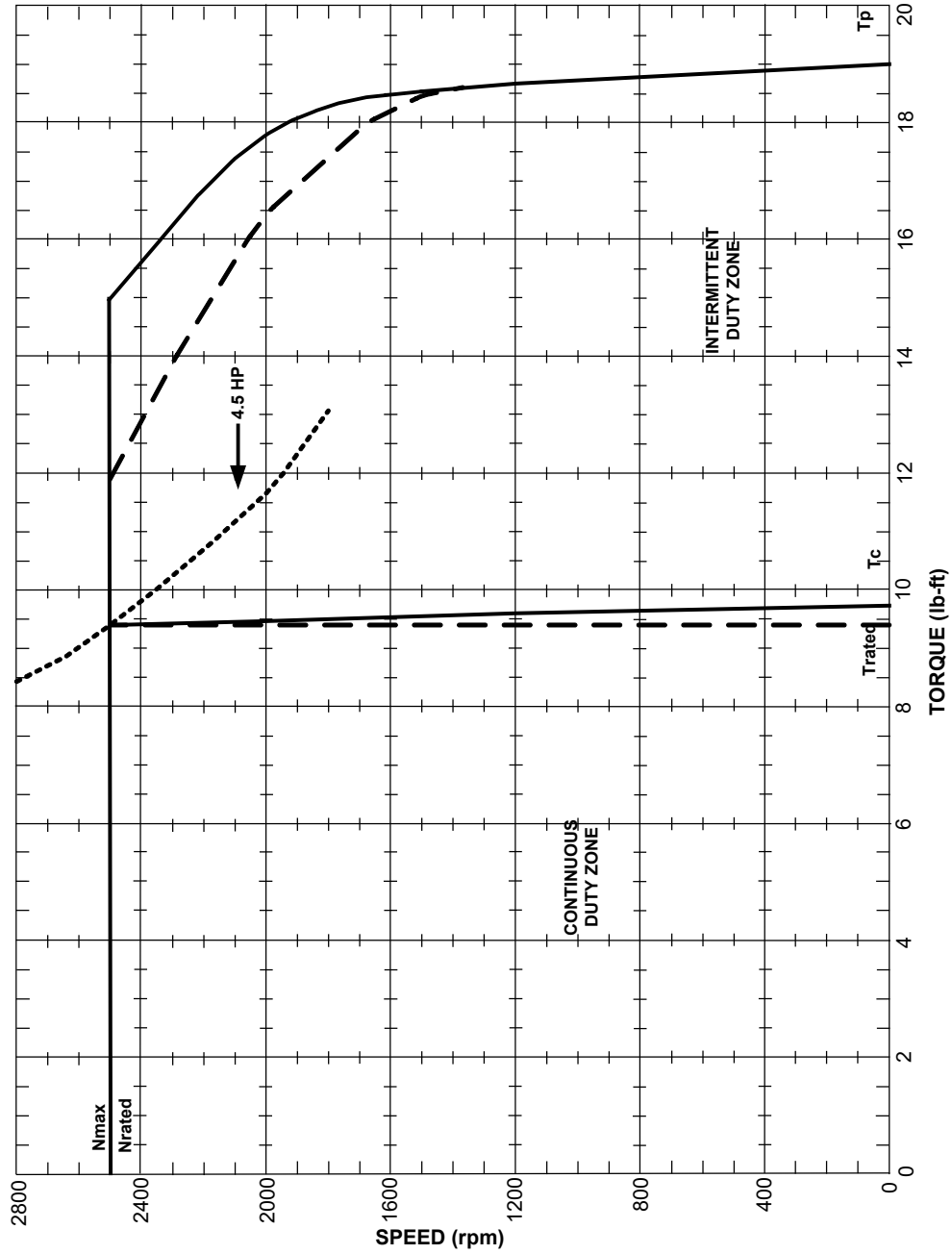

3.4.2.3 EB-404-C PC 26630

NOTE

Do not operate this motor outside the parameters shown on this performance curve.

Motor EB-404-C
 Drive BDS4-220H
 Test T3-1401

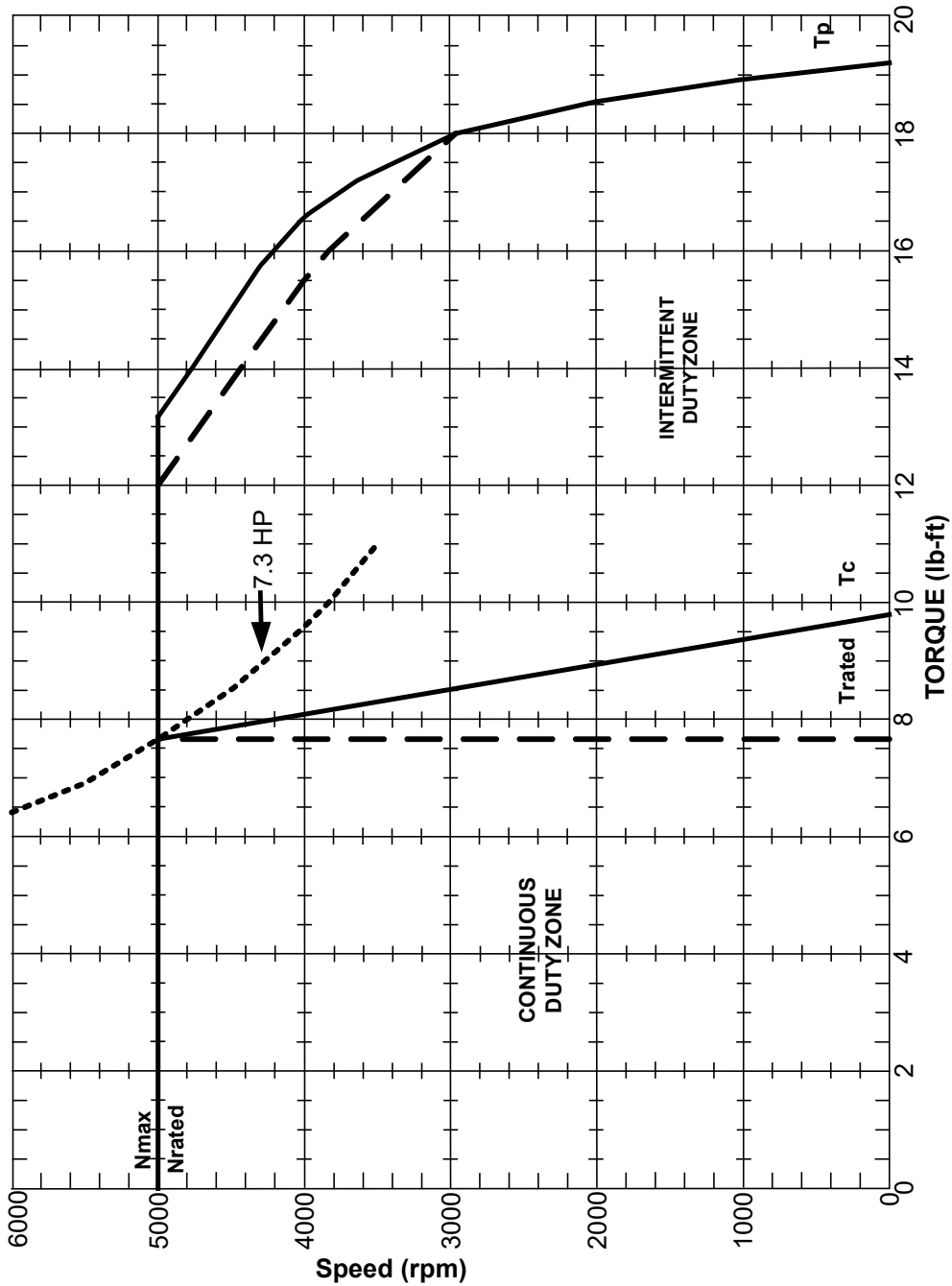

3.4.2.4 EB-404-D PC 26796

NOTE

This motor is not to be operated outside the parameters shown on the respective performance curve.

Motor EB-404-D
 Drive 15-amp continuous/45-amp peak
 Test Calculated

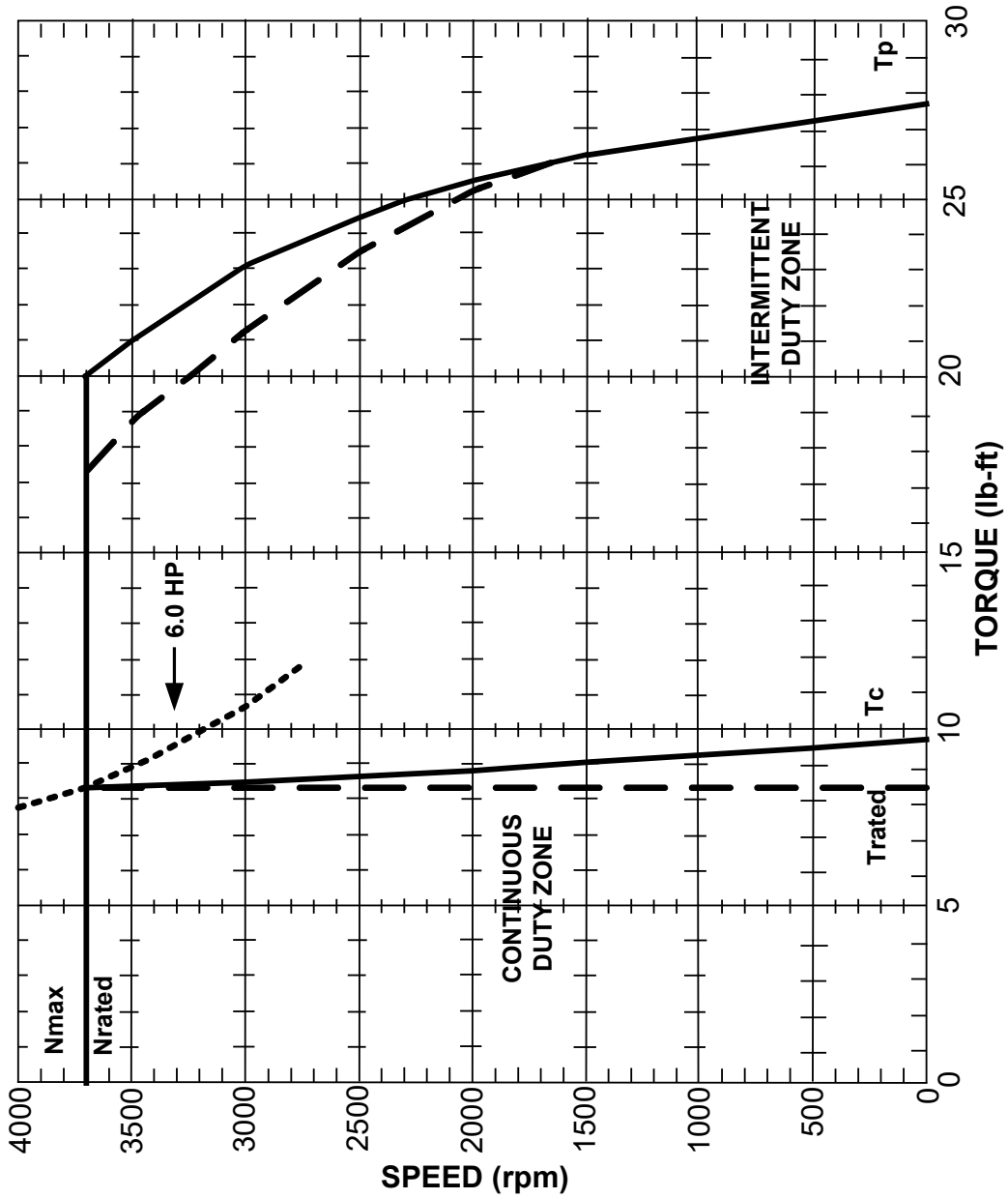

3.5 EB-406

3.5.1 Specifications CD 27012

Specification	Tol	Symbol	Units	A	B	C	D
*Continuous Torque (stall) at 40° C Ambient	Nom.	T _C	lb-ft	13.00	13.70	12.50	13.70
			N-m	17.6	18.6	17.0	18.60
Cont. Line Current	Nom.	I _C	A _{RMS}	9.5	19.1	27.2	15.0
†Max. Speed	Nom.	N max.	rpm	1700	3200	5000	2500
*Peak Torque	Nom.	T _P	lb-ft	35.8	36.5	35.6	39.0
			N-m	27.3	53.3	81.4	45.0
Peak Line Current	Nom.	I _P	A _{RMS}	27.3	53.3	81.4	45.0
129.2†Theoretical Acceleration	Nom.	∞m	rad/sec ²	52263	53285	51971	56934
†Horsepower	Rated	H _P rtd	HP	3.9	7.4	9.6	5.7
†Speed	Rated	N rtd	rpm	1700	3200	5000	2500
†Torque	Rated	T rtd	lb-ft	12.0	12.1	10.1	12.0
			N-m	16.3	16.4	13.7	16.3
Volts (line to line)	Rated	V rtd	V _{RMS}	230	230	230	230
*Torque Sensitivity	± 10%	K _T	lb-ft / A _{RMS}	1.38	0.72	0.46	0.913
			N-m / A _{RMS}	1.868	0.98	0.63	1.238
Back EMF (line-to-line)	± 10%	K _B	V/krpm	113.2	58.8	37.7	74.9
Max. line-to-line volts	Max.	V max	V _{RMS}	250	250	250	250
DC Res at 25° C (line-to-line)	± 10%	R _M	ohms	1.70	0.44	0.20	0.75
Inductance (line-to-line)	± 30%	L _M	mH	42	12	4.8	20.0
Time Constant at 25° C	Mech.	Nom.	T _M	ms	0.676	0.646	0.672
	Elec.	Nom.	T _E	ms	24.7	27.3	24.0
System Performance Curve				26631	26632	26950	26797

*At ultimate winding temperature for ambient data multiply by 1.06

†	Symbol	Units	Value
Rotor Inertia	J_M	lb ft sec ²	0.000685
		kg m ²	0.000929
Weight	Wt	lb	35.0
		kg (f)	15.9
Static Friction	T_F	lb-ft	0.212
		N-m	0.287
Thermal Time Constant Peak	TCTP	Minutes	12
Viscous Damping ∞Z Source	F_1	lb-ft/krpm	0.015
		N-m/krpm	0.020

† If brush type tach is used, these parameters may be affected. Consult the factory.

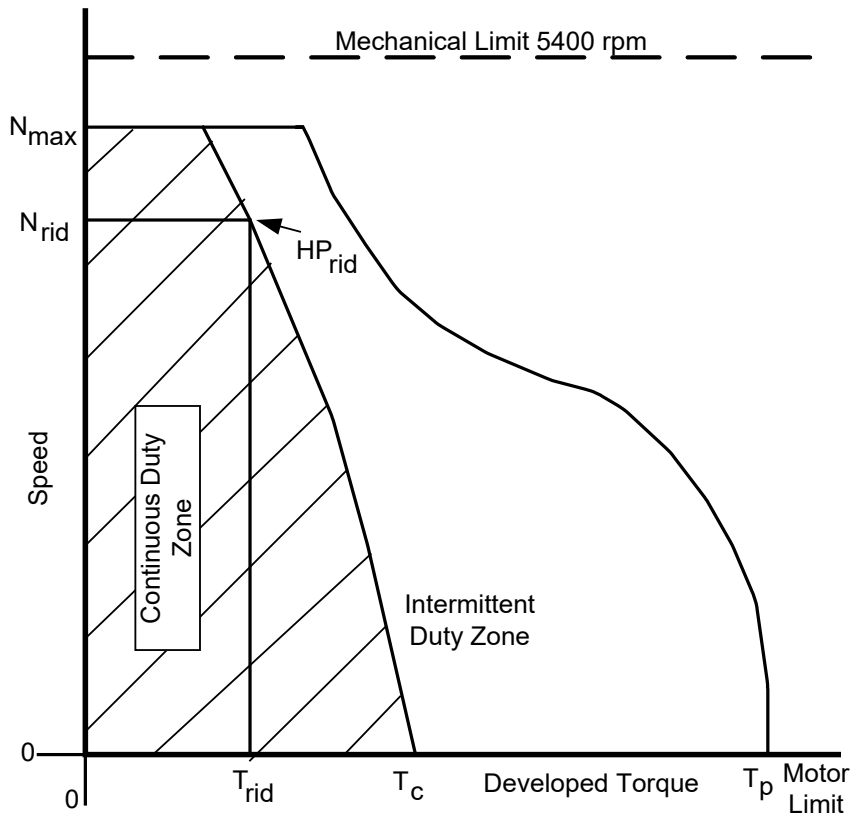

3.5.1.1 EB-406-A PC 26631

NOTE

This motor is not to be operated outside the parameters shown on the respective performance curve.

Motor EB-406-A
 Drive BDS4-210H
 Test T3-1431

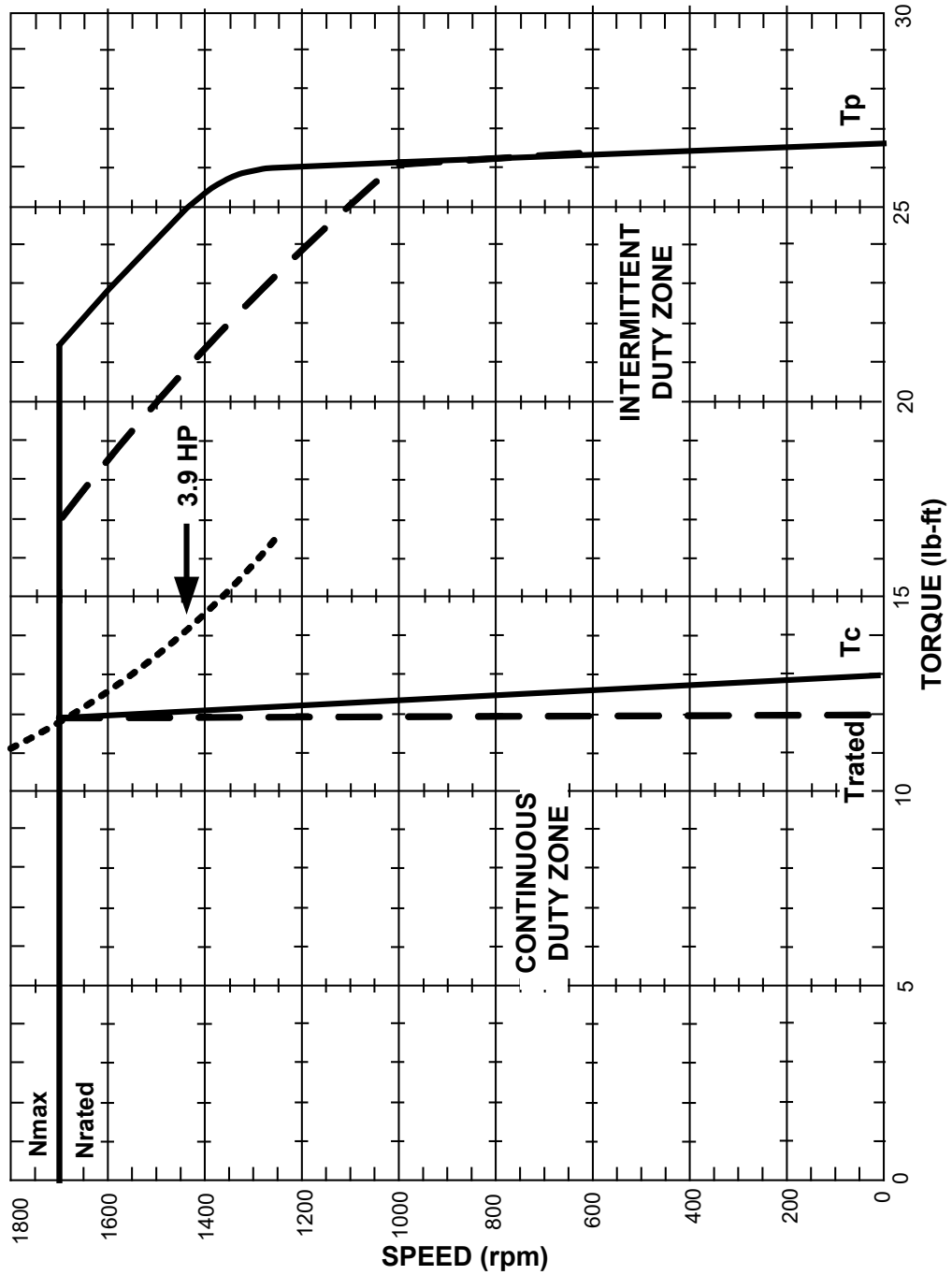

3.5.1.2 EB-406-B PC 26632

NOTE

This motor is not to be operated outside the parameters shown on the respective performance curve.

Motor EB-406-B
 Drive BDS4-220H
 Test T3-1412

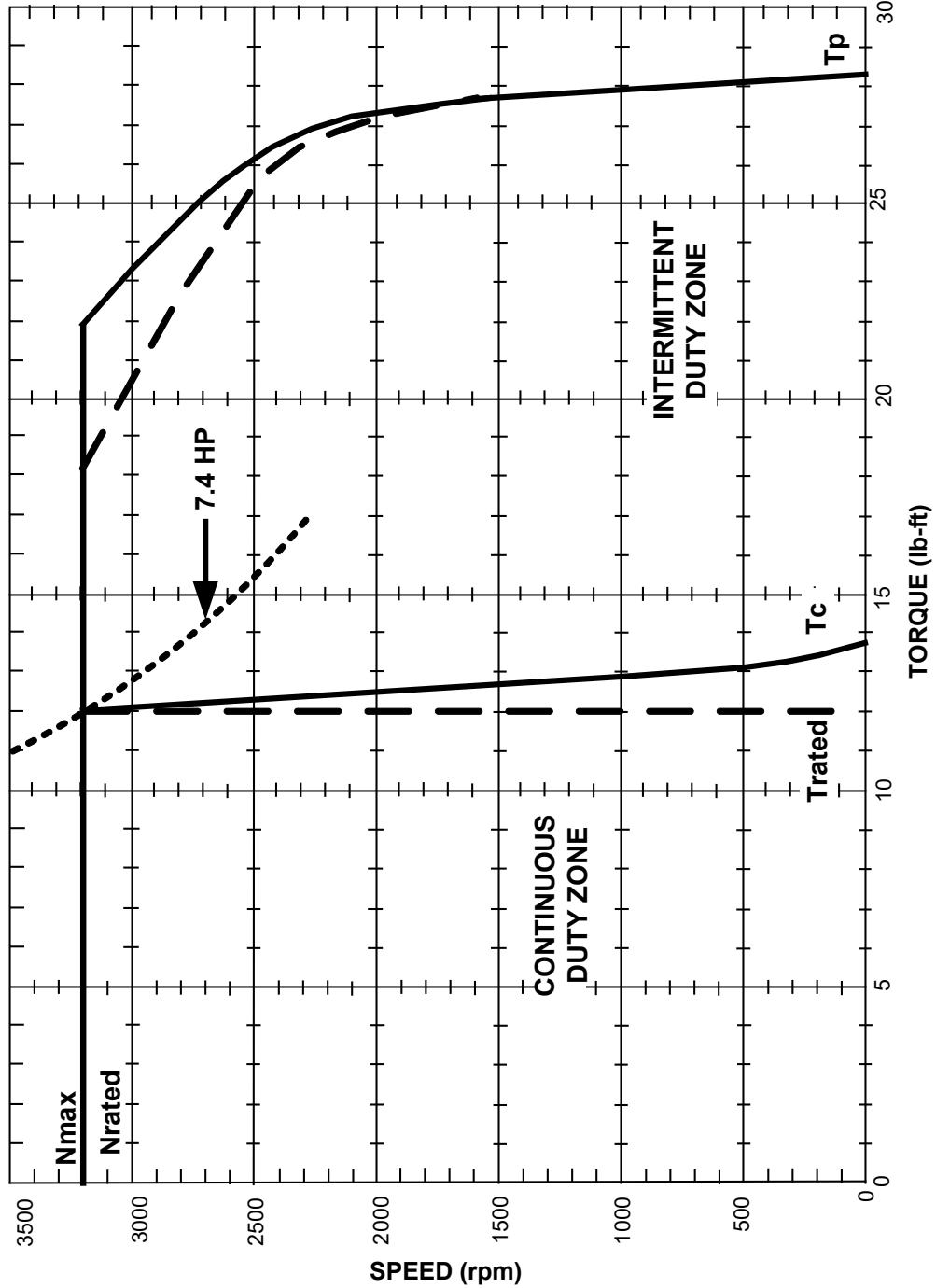

3.5.1.3 EB-406-C PC 26950

NOTE

This motor is not to be operated outside the parameters shown on the respective performance curve.

Motor EB-406-C
 Drive BDS4-230
 Test T3-1697

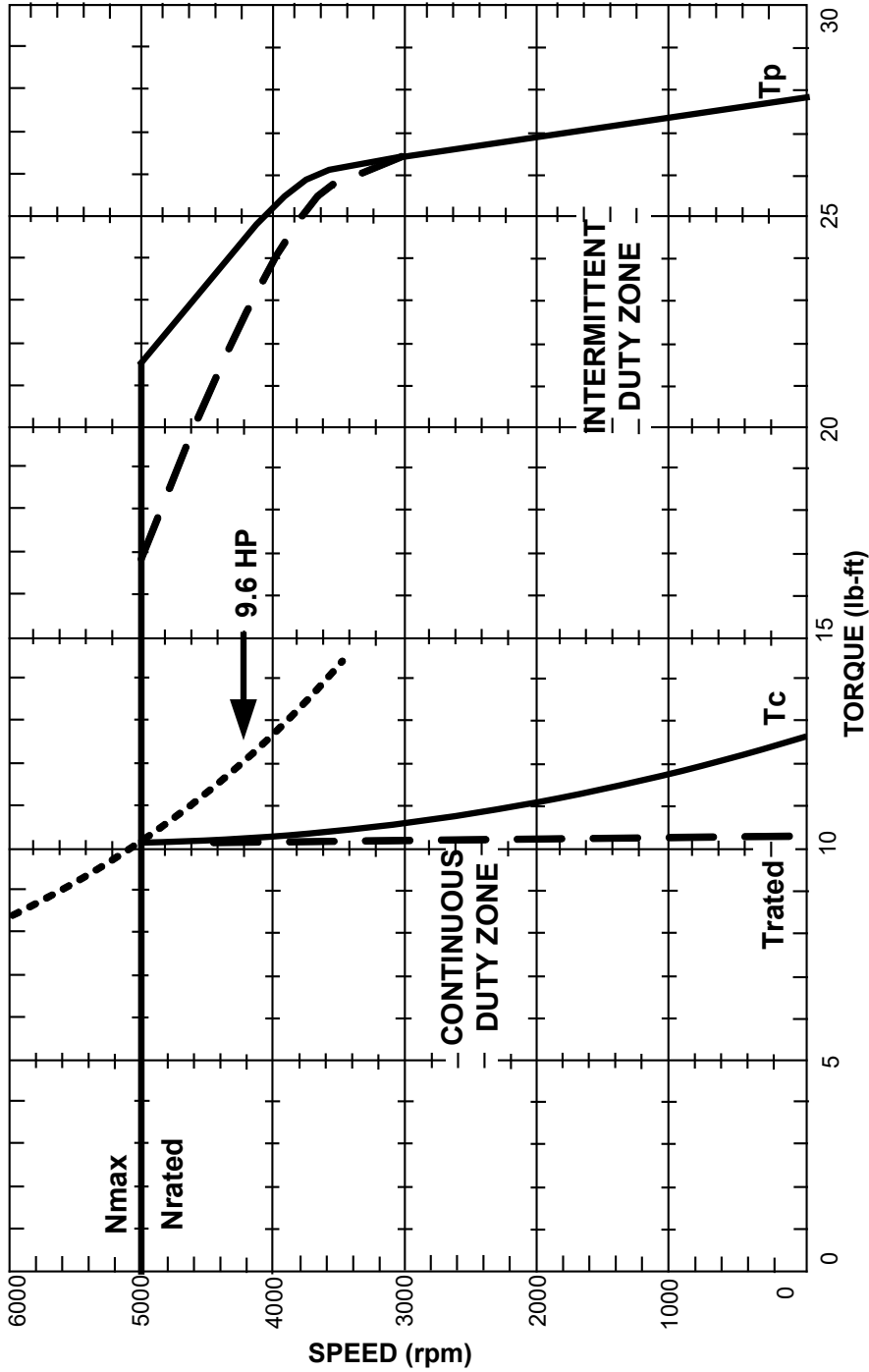

3.5.1.4 EB-406-D PC 26797

NOTE

This motor is not to be operated outside the parameters shown on the respective performance curve.

Motor EB-406-D
 Drive 15-amp continuous/45-amp peak
 Test Calculated

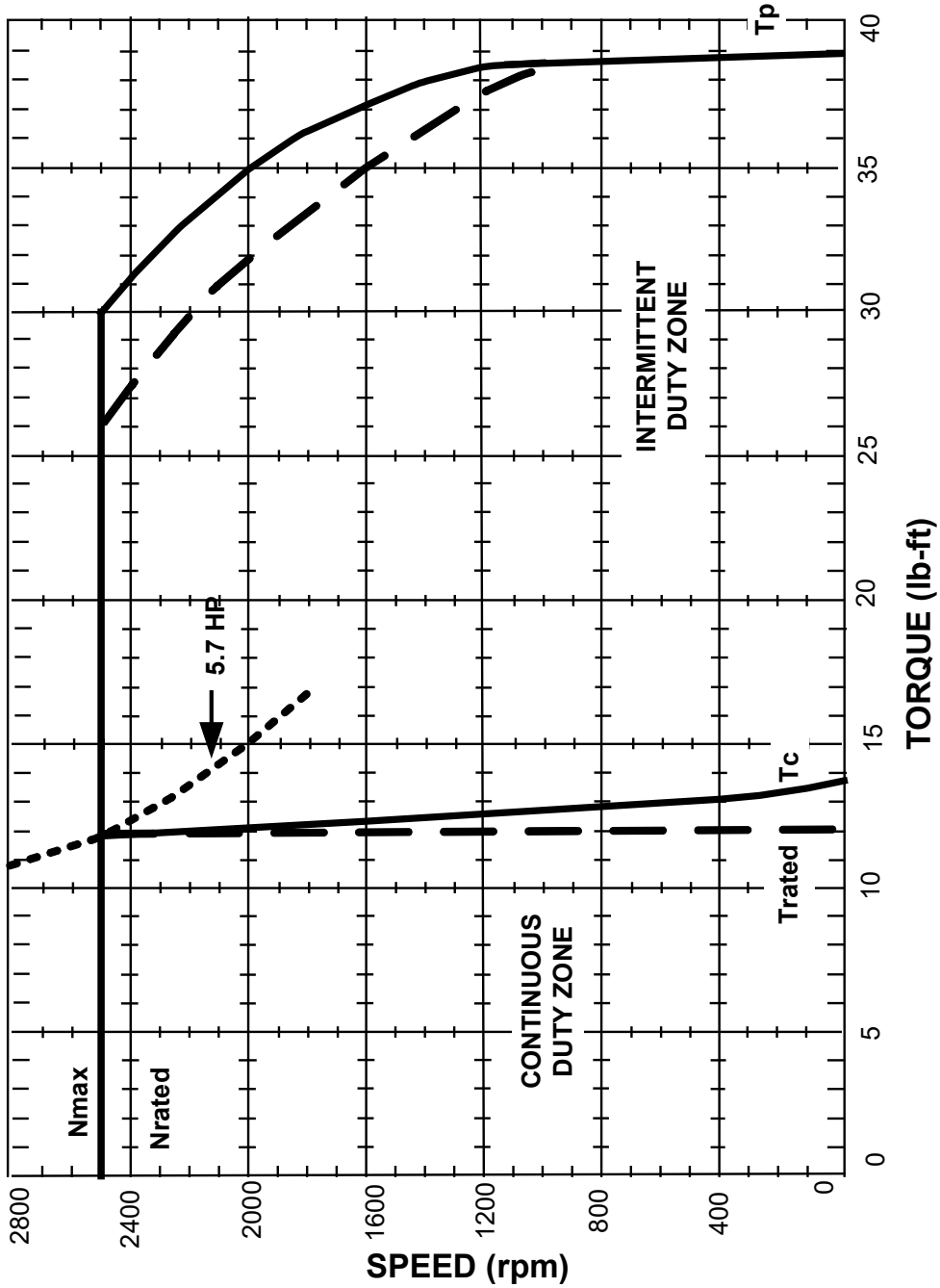

3.6 EB-40x Typical Current and Voltage (Wave Forms at Motor)

3.6.1 Current Phase C

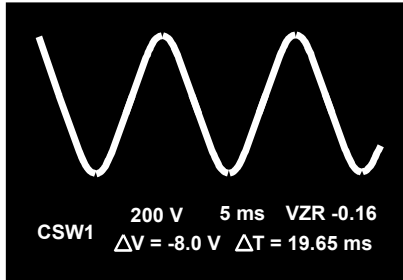

3.6.2 Voltage line a-c

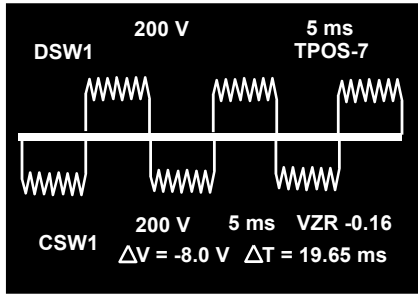

The EB-406 is illustrated at 2500 rpm, 10.7 lb-ft.

3.7 EB-40x Intermittent Duty Operation

If a motor operates intermittently, it is not necessary that the peak load torque fall within the motor's continuous torque capabilities. However, it is important that the RMS (root mean square) load torque be inside the continuous duty zone. The key here is that a sufficient OFF time follows each ON time of the motor. The RMS torque is given by (EQ-1):

$$(EQ-1) \quad T_{RMS} = \sqrt{\frac{T_1^2 t_1 + T_2^2 t_2 + \dots + T_i^2 t_i}{t_1 + t_2 + \dots + t_i}}$$

T_i = Torque at Time i
 t_i = Duration of time i

This equation assumes t_i is small compared to the thermal time constant for peak power of motor (TCTP) for torque values significantly larger than the continuous torque (T_c). This is not always a good assumption. For cases where torque values significantly exceed T_c , use the following equation:

$$\frac{T_{OUT}}{T_c} = \sqrt{\frac{1 - e^{-ton / \text{Duty cycle} \times TCTP}}{1 - e^{-ton / TCTP}}}$$

where, duty cycle = $\frac{ton}{ton + t_{OFF}}$
 T_{OUT} = output torque
 T_c = continuous torque at operating speed
 t_{ON} = time on
 $TCTP$ = thermal time constant for peak power of motor

(EQ-2) expresses operating torque as a function of ON time. It also breaks the operating cycle down into individual periods of ON time and OFF time. Substituting for duty cycle and solving for t_{OFF} , the above equation yields:

$$(EQ-2) \quad t_{off} = -TCTP \ln \left[1 - \frac{1 - e^{-ton / TCTP}}{T_c^2} * T_{OUT}^2 \right] - ton$$

For a specific output torque and a given ON time, the required OFF time is known. This OFF time is required so the motor cools sufficiently and does not exceed its thermal limits. The calculated OFF time should proceed the initial ON time to ensure that the ultimate temperature is not surpassed on the first cycle.

It may also be useful to calculate a time to ultimate experience temperature based on a one-time excursion from ambient temperature. Consider the (EQ-3) AND (EQ-4):

$$(EQ-3) \quad T_{R \text{ Actual Above Ambient}} = T_{R \text{ Rated Above Ambient}} \left[\frac{T_{OUT}}{T_c} \right]^2$$

$$(EQ-4) \quad T_{R \text{ Rated}} = T_{R \text{ Ultimate}} (1 - e^{-})$$

where = time / TCTP

substitute (3) into (4) and obtain

$$T_{R \text{ actual}} \left[\frac{T_c}{T_{OUT}} \right]^2 = T_{R \text{ Ultimate}} (1 - e^{-t/TCTP})$$

To find the time to ultimate temperature, set $T_{R \text{ actual}} = T_{R \text{ ultimate}}$ and solve for t. This yields (EQ-5):

$$(EQ-5) \quad t_{\max} = TCTP \ln \left[1 - \left(\frac{T_c}{T_{OUT}} \right)^2 \right]$$

where: t = max on time
 $TCTP$ = thermal time constant of motor
 T_c = continuous torque of the motor at the particular operating speed
 T_{OUT} = operating torque

This gives the maximum ON time for a given operating torque beginning at ambient temperature. Examination of this equation reveals that as T_{OUT} approaches T_c , t approaches infinity. This is expected since we can theoretically operate the motor indefinitely at continuous torque without exceeding its thermal limits. (EQ-5) in conjunction with (EQ-2) defines the motor's operating time limits.

Example #1

An EB-406-C has the torque vs. speed performance characteristics described in the performance curve, EB-406-C PC 26950. The motor is operating intermittently at 5000 rpm with a torque of 21.5 lb. ft.

FIND:

- a) maximum ON time without exceeding ultimate temperature
- b) the required OFF time for an ON time of 4 seconds

GIVEN: $T_{OUT} = 21.5$ lb-ft

The continuous torque at 5000 rpm is obtained from the performance curve, EB-406-C PC 26950.

$$T_c = 10.2 \text{ lb-ft}$$

From Specifications CD 27012 for the EB-406-C motor:

$$TCTP = 12 \text{ min.}$$

- a) The maximum ON time is found from (EQ-5):

$$t_{\max} = TCTP \ln \left[1 - \left(\frac{T_{OUT}}{T_c} \right)^2 \right]$$

$TCTP = 12$ min.
 $T_c = 10.2$ lb-ft
 $T_{OUT} = 21.5$ lb-ft

$$t_{\max} = 12 \text{ min} \ln \left[1 - \left(\frac{21.5}{10.2} \right)^2 \right]$$

$t_{\max} = 12 \text{ min.} \ln [0.7750]$
 $t_{\max} = 12 \text{ min} (0.2549)$
 $t_{\max} = 3.06 \text{ min.}$

If the motor has an ON time greater than 3.06 minutes, it exceeds the thermal limits.

- b) The required OFF time for a given ON time is found from (EQ-2).

$$T_{\text{OFF}} = -T_{\text{CTP}} \ln \left[1 - \frac{(1 - e^{-t_{\text{ON}}/T_{\text{CTP}}}) T_{\text{OUT}}^2}{T_{\text{C}}^2} \right] - t_{\text{ON}}$$

$$\begin{aligned} t_{\text{ON}} &= 4 \text{ sec} \\ T_{\text{CTP}} &= 12 \text{ min. } 60 \text{ sec/min} = 720 \text{ sec} \\ t_{\text{OUT}} &= 21.5 \text{ lb-ft} \\ T_{\text{C}} &= 10.2 \text{ lb-ft} \end{aligned}$$

$$T_{\text{OFF}} = -720 \text{ sec} \ln \left[1 - \frac{(1 - e^{-4/720}) 21.5^2}{(10.2)^2} \right] - 4 \text{ sec}$$

$$\begin{aligned} T_{\text{OFF}} &= -720 \text{ sec} \ln 0.9755 - 4 \text{ sec} \\ T_{\text{OFF}} &= 13.9 \text{ sec} \end{aligned}$$

For the EB-406-C motor operating at the load point in this example, an ON time of 4 sec must be followed by an OFF time of 13.9 sec. so as not to exceed its thermal limits.

Example #2

The motor of Example #1 is running at 2500 rpm with an intermittent operating torque of 26.7 lb-ft

FIND:

- a) max. ON time
- b) required OFF time for an ON time of 4 sec.

Given $T_{\text{OUT}} = 26.7 \text{ lb-ft}$

From performance curve, EB-406-C PC 26950,
 T_{C} at 2500 rpm = 10.7 lb-ft

From Specifications CD 27012,
 $T_{\text{CTP}} = 12 \text{ min.}$

- a) Using (EQ-5) and above values:
 $t_{\text{MAX}} = 2.1 \text{ min.}$
- b) Using (EQ-2) and an ON time of 4 sec, an OFF time is:
 $t_{\text{OFF}} = 21.3 \text{ sec.}$

Example #3

The motor of Example 1 is running at 750 rpm with an intermittent operating torque of 27.5 lb.-ft.

FIND:

- a) max. ON time
- b) required OFF time for an ON time of 4 sec

GIVEN $t_{out} = 27.5$ lb.-ft

From performance curve, EB-406-C PC 26950,
 $T_c = 11.8$ lb-ft at 750 rpm

From Specifications CD 27012,
TCTP = 12 minutes

- a) Using EQ-5 and above values:
 $t_{MAX} = 2.4$ minutes
 $t_{ON} = 4$ sec
- b) Using (EQ-2) and known values
 $t_{OFF} = 18$ sec

NOTE

The applications engineers at Kollmorgen can assist in the proper sizing of the motor and amplifier based on the applications' duty cycle. Contact them if any questions arise in the derivation of t_{MAX} or t_{OFF} with a specific duty cycle

4. TYPICAL AMPLIFIER DATA PACKAGE

The product features are:

- 30 microprocessor synthesized sine-wave control
- Three AC current loops – fully integrating velocity loop
- OK to Enable or Drive-Up relay
- Inhibit function
- Current monitor

4.1 Typical Amplifier Specifications

Amplifier Specifications		
Input Power to Amplifier	230 VRMS L-L 30 (±15%)	
	Isolation Transformer Not Required	
	115 VAC 10 Control Power (+10%, -15%)	
Output Power to Motor	Power Supply DC Bus	325 VDC nominal, no load
	Output at rated load%	230 VRMS L-L, Nominal ±15% Pulse Width Modulated
	Cont. Current (ARMS/Phase)	Intermittent Current (5 sec. max., 25% duty cycle)
	As required to produce motors rated current	200% of continuous
Ambient Operating Temperature	0-55° C	
Switching Frequency	10 kHz	
Cooling	Fan, Convection (cold plate)	

Save these instructions for future reference.

5 INDEX

Amplifier	
ambient temperature	53
continuous current	53
cooling	53
input power to amplifier	53
isolation transformer	53
output at rated load.....	53
power supply DC bus	53
power supply settings	6
Ratings	6
specifications	53
switching frequency	53
typical.....	5
Axes	
total number allowed	14
Axis	
currents.....	21
Brake	23
electrical interlock circuit.....	23
Breaker	
sizing.....	21
Cable	14
Cables	
AC lines	21
resolver.....	14
shielded	14
Choke	15
Cooling	6
EB 402.....	31
EB 402-B	
performance curve.....	33
EB 402-C	
performance curve.....	34
EB 404.....	36
SPECIFICATIONS.....	41
EB 404-A	
performance curve.....	38
EB 404-B	
performance curve	39
EB 404-C	
performance curve	40
EB 404-D	
performance curve	41
EB 406-B	
performance curve	45, 46
EB 406-C	
performance curve	46
EB 406-D	
performance curve	47
EB-20x	
amplifier data package	53
EB-40x	5
Filter	15
Fuse sizing.....	21
Grounding	26
Input Power.....	6
Intermittent Duty Operation.....	48
Master/Slave	
setup.....	17, 18
Model Number System	28
Motor	
brushless	5
data package	28
final data package	28
thermostat	13, 23
Outline / Connection 3 Phase Power Trans	23
Outline Drawings.....	29, 30
Output Power	6
Power Supply	
fault contact	21
Ratings	6
Power Terminal Blocks	21
Preliminary Checks	26

AC INPUT VOLTAGE.....	26	Temperature	
DC OUTPUT VOLTAGE.....	27	ambient.....	6
PSR4/5		operating	6
breakers.....	13	Thermostat.....	23
fault contacts	13	Torque	
fuses	13	recommended	14
wire sizes.....	13	Wave Forms.....	48
Rating		Wire	
Power Supply	6	control.....	21
Relay		gauge	21
thermal overload.....	14	signal.....	21
Resistor	13	Wiring.....	7
mounting.....	21	AC lines.....	14
Resolver		control.....	13
leads	23	control power.....	14
Signal Inputs		diagram	17, 18, 19, 20, 22
modes of operation.....	26	National Code.....	7
Switching Frequency.....	6	power terminal blocks	13
System		resolver.....	21
setup.....	17, 18	signal	13
		thermostat	21
		Wiring Diagrams	8

About Kollmorgen

Kollmorgen is a leading provider of motion systems and components for machine builders. Through world-class knowledge in motion, industry-leading quality and deep expertise in linking and integrating standard and custom products, Kollmorgen delivers breakthrough solutions that are unmatched in performance, reliability and ease-of-use, giving machine builders an irrefutable marketplace advantage.



Join the [Kollmorgen Developer Network](#) for product support. Ask the community questions, search the knowledge base for answers, get downloads, and suggest improvements

North America Kollmorgen

201 West Rock Road
Radford, VA 24141 USA

Web: www.kollmorgen.com
Mail: support@kollmorgen.com
Phone: 1-540-633-3545
Fax: 1-540-639-4162

Europa Kollmorgen Europe GmbH

Pempelfurtstr 1
40880 Ratingen, Germany

Web: www.kollmorgen.com
Mail: technik@kollmorgen.com
Phone: + 49-2102-9394-0
Fax: + 49 -2102-9394-3155

China & SEA Kollmorgen

Rm 302, Building 5
Lihpao Plaza, 88 Shenbin Road
Minhang District, Shanghai, China

Web: www.kollmorgen.cn
Mail: sales.asia@kollmorgen.com
Phone: + 86-400-661-2802
Fax: +86-21-6248-5367

KOLLMORGEN®

Because Motion Matters™