

Digital Link Accessories Hardware Manual



Version 2.1
Catalog No. M.3000.0343
Part No. M.3000.1386



IND. CONT. EQ.
89X2

Keep all product manuals as a product component during the life span of the product.
Pass all product manuals to future users/owners of the product.

KOLLMORGEN®

Because Motion Matters™

Record of Revisions

Edition	Valid for	Description
08/2010	PiCPro V18.0	Slice I/O Release
01/2011	PiCPro V18.0 SP1	DL-DIU Release
05/2011	PiCPro V18.0 SP1	Added AT2-R833 Slice I/O Coupler
08/2012	PiCPro V18.0 SP3	Added several Slice I/O Modules

Third party brands and trademarks are the property of their respective owners

Technical changes to improve the performance of the equipment may be made without notice!

Printed in USA

All rights reserved. No part of this work may be reproduced in any form (by printing, photocopying, microfilm or any other method) or processed, copied or distributed by electronic means without the written permission of Kollmorgen.

NOTE

These products are being manufactured and sold by G & L Motion Control, Inc., a Kollmorgen company.

Progress is an on-going commitment at Kollmorgen. We continually strive to offer the most advanced products in the industry; therefore, information in this document is subject to change without notice. The text and illustrations are not binding in detail. Kollmorgen shall not be liable for any technical or editorial omissions occurring in this document, nor for any consequential or incidental damages resulting from the use of this document.

Kollmorgen makes every attempt to ensure accuracy and reliability of the specifications in this publication. Specifications are subject to change without notice. Kollmorgen provides this information "AS IS" and disclaims all warranties, express or implied, including, but not limited to, implied warranties of merchantability and fitness for a particular purpose. It is the responsibility of the product user to determine the suitability of this product for a specific application.

DO NOT ATTEMPT to use any Kollmorgen product until the use of such product is completely understood. It is the responsibility of the user to make certain proper operation practices are understood. Kollmorgen products should be used only by qualified personnel and for the express purpose for which said products were designed.

Should information not covered in this document be required, contact the Customer Service Department, Kollmorgen, 672 South Military Road, P.O. Box 1960, Fond du Lac, WI 54936-1960. Kollmorgen can be reached by telephone at (920) 921-7100 or (800) 558-4808 in the United States or by e-mail at glmotion.support@kollmorgen.com.

Catalog No. (Order No.) M.3000.0343

Printed Version Part No. M.3000.1386

Electronic Version Part No. M.3000.1385

Release 08152012

©2012, Kollmorgen

Table of Contents

Table of Contents	3
1 Introduction to Digital Link Accessories	5
1.1 Overview.....	5
1.2 Contents of This Manual.....	5
1.3 Software and Manuals.....	5
1.3.1 Required Software and Manuals.....	5
1.3.2 Suggested Manuals	5
1.4 Kollmorgen Support Contact	6
2 Safety Precautions	7
2.1 System Safety	7
2.1.1 User Responsibility	7
2.1.2 Safety Instructions.....	7
2.2 Safety Signs	8
2.3 Warning Labels.....	8
2.4 Safety First	9
2.5 Safety Inspection	9
2.5.1 Before Starting System	9
2.6 After Shutdown	9
2.7 Operating Safely	10
2.8 Electrical Service & Maintenance Safety	10
2.9 Safe Cleaning Practices	11
3 Slice I/O	13
3.1 Introduction.....	13
3.2 Features	13
3.3 Overview.....	13
3.4 Slice I/O Coupler Major Components	13
3.5 Power Supply Requirements	15
3.5.1 System Power.....	15
3.5.2 Field Power	15
3.5.3 Non-24Vdc Field Power	15
3.6 Module Installation.....	16
3.6.1 DIN Rail Installation.....	16
3.6.2 Slice I/O Coupler Installation.....	16
3.6.3 Slice I/O Module Installation.....	17
3.7 Module Removal.....	17
3.7.1 Slice I/O Coupler Removal.....	17
3.7.2 Slice I/O Module Removal.....	18
3.8 Removable Terminal Block Operation.....	18
3.9 Slice I/O Coupler Details	19
3.9.1 LED Indicators.....	19
3.9.2 Node Address Rotary Switches)	20
3.9.3 Digital Link Ports	21
3.9.4 Power Input Connector	23
3.9.5 DC Input Connectors.....	24
3.9.6 DC Output Connectors.....	26
3.9.7 Slice I/O Coupler Wiring Examples	27
3.10 Slice I/O Modules	30
3.10.1 Slice I/O Limitations and Precautions	30

3.10.2 Slice I/O Modules	30
3.11 Slice I/O Coupler Specifications.....	37
4 Digital Link Drive Interface Unit	39
4.1 DL-DIU Front Panel Details.....	41
4.1.1 LED Indicators	41
4.1.2 Power Indicator Details.....	41
4.1.3 Diagnostic Indicator Details	41
4.1.4 Digital Link LEDs	41
4.1.5 Node Address Rotary Switches.....	42
4.1.6 Digital Link Ports.....	43
4.1.7 Axis I/O Port	45
4.1.7.1 Axis I/O Port DC Outputs	49
4.1.7.2 Axis I/O Port DC Input.....	51
4.1.7.3 Axis I/O Port Analog Output	52
4.1.7.4 Axis I/O Port Encoder Input.....	53
4.1.8 I/O and Power Ports	54
4.1.9 I/O Port Details	56
4.1.9.1 I/O Port Input.....	56
4.1.9.2 Analog Input.....	57
4.1.9.3 I/O Port Wiring Example.....	57
4.2 Specifications.....	59
5 CE and EMC Guidelines.....	63
5.1 Background on EMC (Electromagnetic Compatibility) Compliance	63
5.2 Background on Low Voltage Compliance	63
5.3 RFI Emission and Immunity	63
5.4 Classes of EMC Operating Environments.....	64
5.5 Conformance with the EMC Directive	65
5.6 Conformance With the Low Voltage Directive.....	65
5.7 Changes to the PiC Products.....	65
5.7.1 Changes Affecting the User.....	65
5.8 Using CE/EMC and Non-CE/EMC Modules	68
5.9 Declarations of Conformity.....	70
Appendix A - Operation Details.....	75
6.1 Introduction	75
6.2 DC Inputs	75
6.3 DC Outputs	76
6.3.1 Inductive Loads	76
6.4 Encoder Inputs.....	77
Index	79
Sales and Service	82

1 Introduction to Digital Link Accessories

1.1 Overview

This manual covers all products that reside on the Digital Link communication network, but that are neither Controls nor Drives.

1.2 Contents of This Manual

This manual includes the following major topics:

- Information to safely operate and maintain the equipment in a safe manner.
- User responsibilities for product acceptance and storage.
- Power and environmental information for general power, control cabinet, grounding, heat control and handling.
- Procedures for mounting, wiring, and connecting the Accessories to the control system.
- Recommended system wiring guidelines for signal separation, differential devices, and to ensure ElectroMagnetic Compatibility.
- The location of connectors on the Accessory and descriptions of their functionality.
- Physical, electrical, environmental and functional specifications/dimensions.
- Description of the minimal maintenance necessary.
- A troubleshooting chart of potential problems and possible solutions.
- Part numbers and descriptions for the drive and related equipment.

1.3 Software and Manuals

1.3.1 Required Software and Manuals

PiCPro (one of the following)

- Professional Edition
- MMC Limited Edition
- Monitor Edition (Diagnostics Only)

1.3.2 Suggested Manuals

- MMC smart Drive and Digital MMC Control Hardware Manual
- Standalone MMC Hardware Manual
- Function/Function Block Reference Guide
- Motion Application Specific Function Block Manual
- Ethernet Application Specific Function Block Manual
- General Purpose Application Specific Function Block Manual

1.4 Kollmorgen Support Contact

Contact your local Kollmorgen representative for:

- Sales and order support
- Product technical training
- Warranty support
- Support service agreements

Kollmorgen Technical Support can be reached:

- In the United States, telephone (800) 558-4808
- Outside the United States, telephone (920) 921-7100
- E-mail address: glmotion.support@kollmorgen.com
- Web site: www.kollmorgen.com

2 Safety Precautions

READ AND UNDERSTAND THIS SECTION IN ITS ENTIRETY BEFORE UNDERTAKING INSTALLATION OR ADJUSTMENT OF THE MMC SMART DRIVE AND ANY ASSOCIATED SYSTEMS OR EQUIPMENT

The instructions contained in this section will help users to operate and maintain the equipment in a safe manner.

PLEASE REMEMBER THAT SAFETY IS EVERYONE'S RESPONSIBILITY

2.1 System Safety

The basic rules of safety set forth in this section are intended as a guide for the safe operation of equipment. This general safety information, along with explicit service, maintenance and operational materials, make up the complete instruction set. All personnel who operate, service or are involved with this equipment in any way should become totally familiar with this information prior to operating.

2.1.1 User Responsibility

It is the responsibility of the user to ensure that the procedures set forth here are followed and, should any major deviation or change in use from the original specifications be required, appropriate procedures should be established for the continued safe operation of the system. It is strongly recommended that you contact your OEM to ensure that the system can be safely converted for its new use and continue to operate in a safe manner.

2.1.2 Safety Instructions

- Do not operate your equipment with safety devices bypassed or covers removed.
- Only qualified personnel should operate the equipment.
- Never perform service or maintenance while automatic control sequences are in operation.
- To avoid shock or serious injury, only qualified personnel should perform maintenance on the system.

ATTENTION	
	Do not touch the main power supply fuses or any components internal to the power modules while the main power supply switch is ON. Note that when the main power switch is OFF, the incoming supply cable may be live.

- **GROUNDING (Protective Earth)**

The equipment must be grounded (connected to the protective earth connection) according to OEM recommendations and to the latest local regulations for electrical safety. The grounding (protective earth) conductor must not be interrupted inside or outside the equipment enclosures. The wire used for equipment grounding (connection to protective earth) should be green with a yellow stripe.

2.2 Safety Signs

The purpose of a system of safety signs is to draw attention to objects and situations which could affect personal or plant safety. It should be noted that the use of safety signs does not replace the need for appropriate accident prevention measures. Always read and follow the instructions based upon the level of hazard or potential danger.

2.3 Warning Labels

Hazard warning

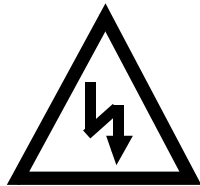

Danger Electric
Shock Risk

When you see this safety sign on a system, it gives a warning of a hazard or possibility of a hazard existing. The type of warning is given by the pictorial representation on the sign plus text if used.

To ignore such a caution could lead to severe injury or death arising from an unsafe practice.

Danger, Warning, or Caution warning

Symbol plus DANGER, WARNING or CAUTION:
These notices provide information intended to prevent potential personal injury and equipment damage.

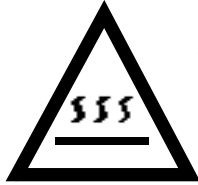
Hot Surface warning

Symbol plus HOT SURFACE:
These notices provide information intended to prevent potential personal injury.

2.4 Safety First

Kollmorgen equipment is designed and manufactured with consideration and care to generally accepted safety standards. However, the proper and safe performance of the equipment depends upon the use of sound and prudent operating, maintenance and servicing procedures by trained personnel under adequate supervision.

For your protection, and the protection of others, learn and always follow these safety rules. Observe warnings on machines and act accordingly. Form safe working habits by reading the rules and abiding by them. Keep these safety rules handy and review them from time to time to refresh your understanding of them.

2.5 Safety Inspection**2.5.1 Before Starting System**

- Ensure that all guards and safety devices are installed and operative and all doors which carry warning labels are closed and locked.
- Ensure that all personnel are clear of those areas indicated as potentially hazardous.
- Remove (from the operating zone) any materials, tools or other objects that could cause injury to personnel or damage the system.
- Make sure that the control system is in an operational condition.
- Make certain that all indicating lights, horns, pressure gauges or other safety devices or indicators are in working order.

2.6 After Shutdown

Make certain all controlled equipment in the plant is safe and the associated electrical, pneumatic or hydraulic power is turned off. It is permissible for the control equipment contained in enclosures to remain energized provided this does not conflict with the safety instructions found in this section.

2.7 Operating Safely

- Do not operate the control system until you read and understand the operating instructions and become thoroughly familiar with the system and the controls.
- Never operate the control system while a safety device or guard is removed or disconnected
- Where access to the control system is permitted for manual operation, only those doors which provide that access should be unlocked. They should be locked immediately after the particular operation is completed.
- Never remove warnings that are displayed on the equipment. Torn or worn labels should be replaced.
- Do not start the control system until all personnel in the area have been warned.
- Never sit or stand on anything that might cause you to fall onto the control equipment or its peripheral equipment.
- Horseplay around the control system and its associated equipment is dangerous and should be prohibited.

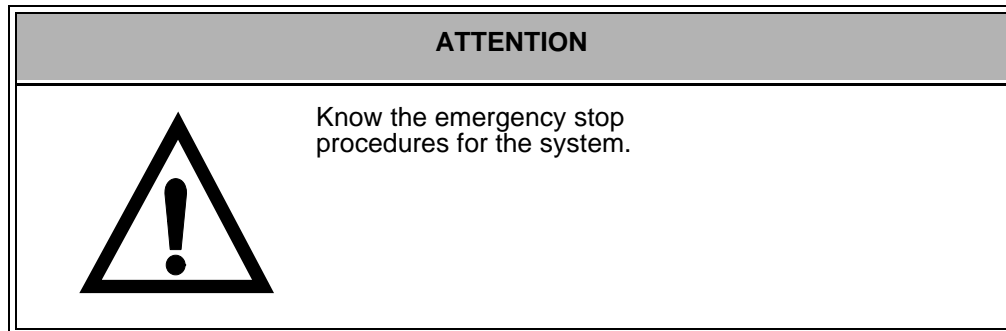

- Never operate the equipment outside specification limits.
- Keep alert and observe indicator lights, system messages and warnings that are displayed on the system.
- Do not operate faulty or damaged equipment. Make certain proper service and maintenance procedures have been performed.

2.8 Electrical Service & Maintenance Safety

- **ALL ELECTRICAL OR ELECTRONIC MAINTENANCE AND SERVICE SHOULD BE PERFORMED BY TRAINED AND AUTHORIZED PERSONNEL ONLY.**
- It should be assumed at all times that the POWER is ON and all conditions treated as live. This practice assures a cautious approach which may prevent accident or injury.
- To remove power:
LOCK THE SUPPLY CIRCUIT DISCONNECTING MEANS IN THE OPEN POSITION.
APPLY LOCKOUT/TAGOUT DEVICES IN ACCORDANCE WITH A DOCUMENTED AND ESTABLISHED POLICY.
- Make sure the circuit is safe by using the proper test equipment. Check test equipment regularly.

- There may be circumstances where troubleshooting on live equipment is required. Under such conditions, special precautions must be taken:
 - Make sure your tools and body are clear of the areas of equipment which may be live.
 - Extra safety measures should be taken in damp areas.
 - Be alert and avoid any outside distractions.
 - Make certain another qualified person is in attendance.
- Before applying power to any equipment, make certain that all personnel are clear of associated equipment.
- Control panel doors should be unlocked only when checking out electrical equipment or wiring. On completion, close and lock panel doors.
- All covers on junction panels should be fastened closed before leaving any job.
- Never operate any controls while others are performing maintenance on the system.
- Do not bypass a safety device.
- Always use the proper tool for the job.
- Replace the main supply fuses only when electrical power is OFF (locked out).

2.9

Safe Cleaning Practices

- Do not use toxic or flammable solvents to clean control system hardware.
- Turn off electrical power (lock out) before cleaning control system assemblies.
- Keep electrical panel covers closed and power off when cleaning an enclosure.
- Always clean up spills around the equipment immediately after they occur.
- Never attempt to clean a control system while it is operating.
- Never use water to clean control equipment unless you are certain that the equipment has been certified as sealed against water ingress. Water is a very good conductor of electricity and the single largest cause of death by electrocution.

3 Slice I/O

3.1 Introduction

This section contains information on Kollmorgen's Slice I/O System of I/O modules. The Slice I/O System allows the user to integrate a variety of Slice I/O modules with any MMC Digital Control via the Digital Link communication interface. Information on Kollmorgen's line of Digital Controls can be found in the Standalone MMC Hardware Manual, and the MMC Smart Drive and Digital Control Hardware Manual.

3.2 Features

The Slice I/O System provides the following features:

- DIN rail mounting
- Removable Terminal Blocks, which allow the user to replace a Module without unwiring/rewiring the Module. (Note: 16 point DC I/O modules do not contain Removable Terminal Blocks. Refer to [Table 3-16 on page 36](#) for available mating connector.)
- Individual Module replacement. Any Module can be replaced without the need to remove any other Module
- The Slice I/O Coupler, which:
 - Provides the interface between the Digital Link communications network and the Slice I/O Modules
 - Provides 16 fast inputs (24Vdc), and 16 fast outputs (24Vdc)
- Slice I/O Modules, that provide I/O between the Digital Control and the machine. Slice I/O Modules include the following:
 - Digital Input Modules (5Vdc, 12Vdc, 24Vdc, 48Vdc, 110Vac, and 220Vac)
 - Digital Output Modules (5Vdc, 24Vdc, 120Vdc, and Relay Out)
 - Analog Input Modules (0-20ma, 4-20ma, 0-10Vdc, +/-10Vdc)
 - Analog Output Modules (0-20ma, 0-1,000ma, 0-5Vdc, 0-10Vdc, +/-10Vdc)
 - Power Supply and Distribution Modules

3.3 Overview

Kollmorgen's Slice I/O System offers a low cost, highly modular solution to system I/O requirements. One Slice I/O Coupler can provide up to 144 input points, and 144 output points, depending on the type of Slice I/O Module installed. Furthermore, a Control System containing a Digital Control can contain from 1 to 32 Slice I/O Couplers, depending on the Control type and other Digital Link devices (typically Kollmorgen Smart Drives) that are installed within the system.

Once properly installed, Slice I/O Input Modules provide machine data to the Application Program, and Slice I/O Output Modules provide machine control from the Application Program. The Application Program is developed using Kollmorgen's PiCPro integrated Application Development Environment.

3.4 Slice I/O Coupler Major Components

The Slice I/O Coupler contains the Digital Link "IN" and "OUT" ports, Digital Link node address switches, 16 fast DC Inputs, 16 fast DC Outputs, and an interface for adding

Slice I/O Modules to the Coupler. The major components of the Slice I/O Coupler are shown in [Figure 3-1](#).

Figure 3-1: Slice I/O Coupler

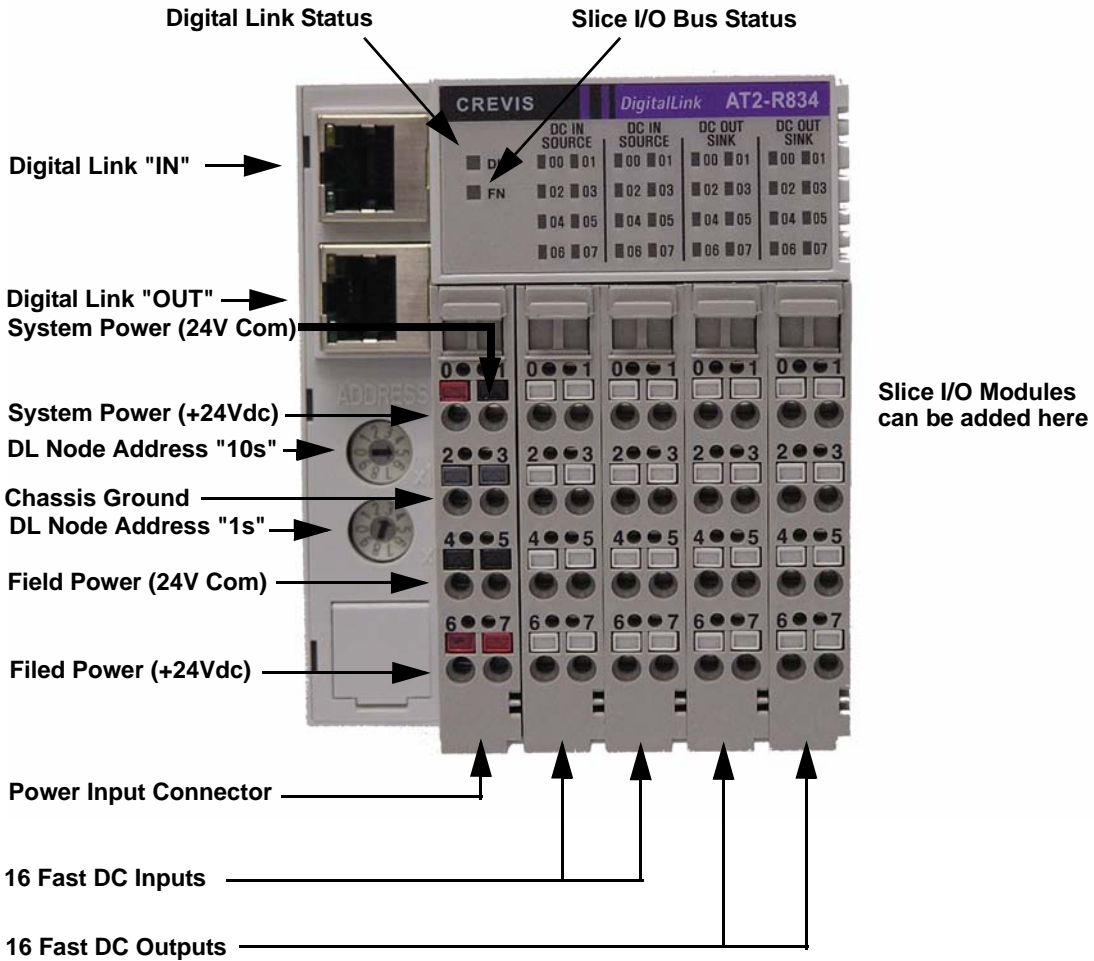

3.5 Power Supply Requirements

Power to the Slice I/O Coupler is provided by the user via the Input Power Connector, located on the far left of the Coupler as shown in [Figure 3-1 on page 14](#).

The Slice I/O System contains two separate and distinct Power Systems. These Power Systems provide the System Power and the Field Power to the Coupler and Slice I/O modules. Each Power System is described below.

3.5.1 System Power

24Vdc (nominal) is provided by the user, and the Slice I/O Coupler converts this to 5Vdc to provide System Power. This 5Vdc supplies the power for the components within the Coupler and the attached Slice I/O modules.

The Coupler can provide a maximum of 1A of 5Vdc power to the attached Slice I/O modules. If the System Power of the attached Slice I/O modules exceeds 1A, an Expansion Power Supply Module (P/N ST-7111) must be installed to provide additional System Power. Refer to the ST-7111 Data Sheet for additional information.

To determine the system System Power requirements, refer to the Data Sheets for all connected Slice I/O Modules for each Module's System Power current usage. The current usage is listed under "Power Dissipation" in the "General Specifications" section in the Data Sheets.

3.5.2 Field Power

24Vdc (nominal) is provided by the user to the Slice I/O Coupler, and the Coupler uses this to power the 16 Fast Inputs and 16 Fast Outputs provided by the Coupler. This 24Vdc is also passed through the Coupler to supply Field Power to any connected 24Vdc Slice I/O Modules.

The Coupler can provide a maximum of 10A of 24Vdc power to power the 16 Inputs and 16 Outputs provided by the Coupler plus the Field Power requirements of the attached Slice I/O modules. If the Field Power required exceeds 10A, an Expansion Field Power Distributor Module (P/N ST-7241) must be installed to provide additional Field Power. Refer to the ST-7241 Data Sheet for additional information.

To determine the system Field Power requirements, refer to the Data Sheets for all connected Slice I/O Modules for each Module's Field Power current usage. The current usage is listed under "Field Power - Power Dissipation" in the "General Specifications" section in the Data Sheets. Then, add the current requirements of any loads connected to the Slice I/O outputs.

3.5.3 Non-24Vdc Field Power

Many Slice I/O modules require Field Power other than 24Vdc, such as 5Vdc, 48Vdc, 110Vac, or 220Vac. When switching between Field Power voltages, it is absolutely necessary to install an Expansion Field Power Distributor (P/N ST-7241) between the Modules. Refer to the ST-7241 Data Sheet for additional information.

WARNING

Failure to read and understand this section can result in damage to the entire Slice I/O System. This damage will not be covered under Kollmorgen's warranty policy.

3.6 Module Installation

The Slice I/O Coupler and Slice I/O Modules are mounted to a DIN Rail that is typically mounted to the user's control panel.

3.6.1 DIN Rail Installation

Mount the required length of DIN rail to the panel within the control cabinet. Make sure that the DIN rail makes good electrical connection to the panel, and that the panel is connected to Single Point Ground. When selecting the DIN rail, Kollmorgen has found that the galvanized product exhibits superior performance, especially in the area of noise emission and suppression.

3.6.2 Slice I/O Coupler Installation

Mount the Slice I/O Coupler on the left of the DIN rail as follows:

- Make certain that the release lever found at the bottom of the Coupler is in the release position. Do this by inserting a flat-bladed screw driver into the Release Tab, and pushing the handle of the screw driver towards the top of the Coupler (using the bottom of the Coupler as a pivot point) until the Release Tab locks in the Release (out) position. Please note that twisting the screwdriver blade while it is in the Release Tab will not move the Release Tab into the Release position.
- Position the Coupler over the DIN rail, making sure that the back of the Coupler is tight against the panel that the DIN rail is mounted to.
- Press the Coupler Release Lever up towards the Coupler, until it snaps into the "lock" (in) position.
- Make sure that the plastic End Cover that is included with the Coupler is installed on the right side of the Coupler to protect the Slice I/O contact pins.

Slice I/O Coupler dimensions are shown in [Figure 3-2 on page 17](#).

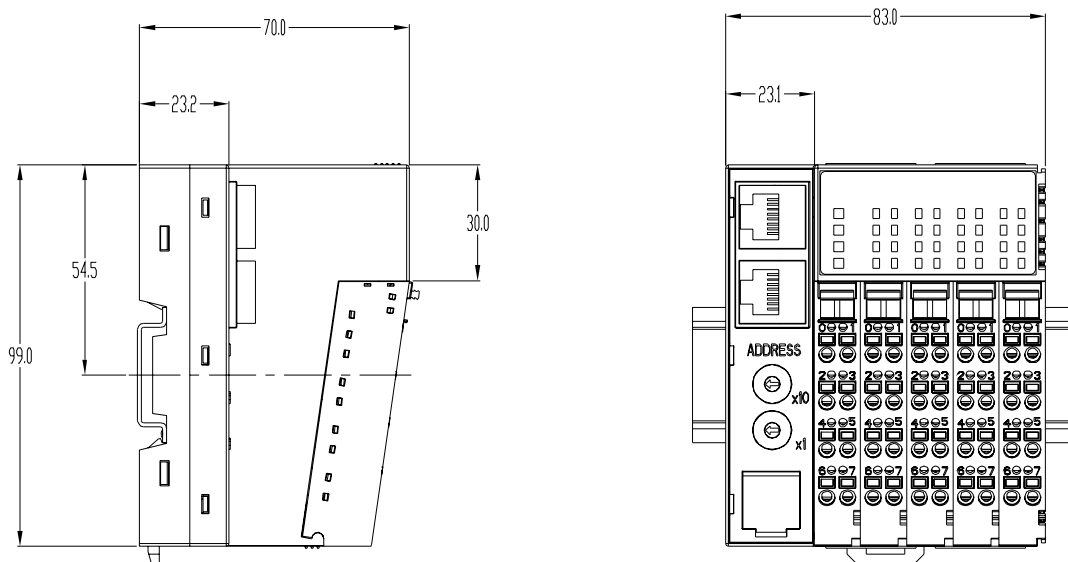
Figure 3-2: Slice I/O Coupler Dimensions

3.6.3 Slice I/O Module Installation

Mount a Slice I/O Module to the right of the Coupler or another Slice I/O Module as follows:

- Remove the End Cover from the right side of the Slice I/O system that the additional Slice I/O Module(s) is being installed on.
- Make certain that the blue release lever found at the bottom of the Module is in the non-release position by rotating the lever towards the bottom of the Module until it is flush with the bottom of the Module.
- Align the plastic guides located at the top and bottom of the Module with the associated slots in the previously mounted Module, and slide the Module down towards the DIN rail
- Press the Module firmly onto the DIN rail until it snaps into place
- Re-install the plastic End Cover that was removed in step one on the right side of the installed Module(s) to protect the Slice I/O contact pins.

3.7 Module Removal

This section describes the steps required to remove the Slice I/O Coupler and a Slice I/O Module from the DIN rail.

3.7.1 Slice I/O Coupler Removal

Perform the following steps to remove a Slice I/O Coupler from the DIN rail:

- If there is a Slice I/O Module attached to the right side of the Coupler, remove it as described in [Section 3.7.2](#) below.
- Locate the Coupler Release Tab located underneath the Coupler
- Insert a flat-bladed screw driver into the Release Tab, and push the handle of the screw driver towards the top of the Coupler (using the bottom of the Coupler as a pivot point) until the Release Tab locks in the Release (out) position. Please note that twisting the screwdriver blade while it is in the Release Tab will not move the Release Tab into the Release position.
- Rock the bottom of the Coupler out of the DIN rail. With the bottom still rocked forward, lift the Coupler straight up and off of the DIN rail.

3.7.2 Slice I/O Module Removal

Perform the following steps to remove a Slice I/O Module from the DIN rail:

- Locate the blue Release Tab at the bottom of the Module.
- Using a flat-bladed screwdriver, rotate the Release Tab down and away from the Module until it stays in the Release position, which is at a right angle to the bottom of the Module.
- Slide the Module away from the DIN rail until it is completely separated from the surrounding Module(s).

3.8 Removable Terminal Block Operation

Connection between Slice I/O Modules and user equipment is made via Removable Terminal Blocks located on each Module. Removable Terminal Blocks allow the replacement of a Module without the need for unwiring/rewiring.

Note: 16 point DC I/O modules do not contain Removable Terminal Blocks. Refer to [Table 3-16 on page 36](#) for available mating connector.

Terminal block Removal:

- Pull the Terminal Block Release Tab, located at the top of the Terminal Block, until the Terminal Block rocks forward and out of the Module.

Terminal Block Insertion:

- Before inserting the Terminal Block into the Module, push the Terminal Block Release Tab, located at the top of the Terminal Block, all the way in to the "lock" position.
- Hook the bottom of the Terminal Block into the Module
- Rock the top of Terminal Block forward until it snaps into the Module

Terminal Block Wiring:

- Use wire up to 14AWG
- Strip .25in (6.35mm) of insulation from the end of the wire
- Using a small flat-bladed screwdriver, depress the Wire Release Tab above the desired terminal
- Insert the previously-strip wire into the terminal hole
- Release the Wire Release Tab

3.9 Slice I/O Coupler Details

This section describes the Slice I/O Coupler, including the LED Indicators, Connectors, and Operation.

3.9.1 LED Indicators

There are 32 LEDs located on the Coupler that indicate the status of the 32 I/O points that are integrated within the Coupler. These LEDs are described in [section 3.9.5 on page 24](#) and [section 3.9.6 on page 26](#).

There two additional LEDs located on the front of the Coupler, as follows:

- The Digital Link Status LED, labeled "DL" on the front of the Coupler as seen in [Figure 3-1 on page 14](#), indicates the status of the communication between the Coupler and the Digital Control. This LED can be in one of three states:
 - Off - the Digital Control running the user's application has not yet initialized the Coupler, or power is not being applied to the Coupler
 - Green - the Coupler is initialized and the user's application is controlling the Coupler. This condition occurs when the Coupler is properly connected to the Digital Control, and the user's application is running (scanning). When the "DL" LED is green, the user's application control's the outputs on the Coupler and all attached Slice I/O Modules.
 - Red - the Coupler is initialized and the user's application is not controlling the Coupler. This condition can occur if the Coupler is disconnected from the Digital Control, or the user's application is stopped (not scanning). When the "DL" LED is red, all outputs on the Coupler and attached Slice I/O Modules are forced off.
- The Slice I/O Communication Link Status LED, labeled "FN" on the front of the Coupler as seen in [Figure 3-1 on page 14](#), indicates the status of the communication between the Coupler and the attached Slice I/O Modules. This LED can be in one of the following three states:
 - Off - The Slice I/O system is not being accessed. All outputs are forced off.
 - Green - The slice I/O system is being properly accessed by the application. Outputs are being controlled by the application, and Inputs are being read by the application.
 - Red - There has been a communication problem between the Slice I/O Coupler and the attached Slice I/O Modules. The outputs on the Coupler continue to be controlled by the user's application, however, the outputs on all attached Slice I/O modules are forced off.

3.9.2 Node Address Rotary Switches)

Two rotary switches are used to set the Digital Link Node address of the Slice I/O Coupler. These are labeled "x10" and "x1" on the front of the Coupler, as seen in [Figure 3-1 on page 14](#). Rotate the switches to the desired address.

Addresses can be set to any number from 1 through 64. The top switch represents values of base ten. The bottom switch represents values of base 1.

As an example, rotating the switch to a setting of 2 on the top switch equals the value of 20 (2×10). Rotating the switch on the bottom switch to a setting of 5 equals the value of 5. The actual address setting is 25 ($20 + 5$).

Address

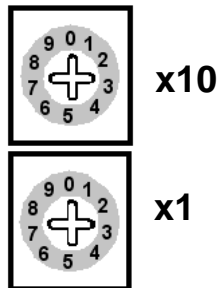

3.9.3 Digital Link Ports

The two 8-pin RJ-45 Digital Link Port connectors, labeled "IN" and "OUT" on the front of the Coupler, (see [Figure 3-1 on page 14](#) for location) provide communications between the Coupler and other Digital Link devices. Each connector is described below:

- Digital Link "IN" Port

Connect the Coupler's Digital Link "IN" port to another Digital Link device's "OUT" port (or the "Digital Link" port if connecting to a Digital Control) using a "straight-through" shielded cable.

In addition, there are two LEDs built into the "IN" port connector, as described below:

- The upper LED will turn yellow to indicate that the Coupler has failed its on-board diagnostics
- The lower LED will turn green to indicate that there is a Digital Link device successfully connected to the "IN" port

- Digital Link "OUT" Port

Connect the Coupler's Digital Link "OUT" port to another Digital Link device's "IN" port using a "straight-through" shielded cable.

In addition, there is an LED built into the lower portion of the "OUT" port connector, which will turn green that there is a Digital Link device successfully connected to the "OUT" port.

- Pin descriptions for are provided in [Table 3-1](#)
- Pin assignments are provided in [Table 3-2](#)
- The available Digital Link Port to Digital Drive cables are described in [Table 3-3](#)

Table 3-1: Digital Link Port Pin Description

Digital Link Connector (IN/OUT) Signals		Pin	
Function	Notes	"In" Connector	"Out" Connector
Receive Data +	Receives data from connected device.	1	3
Receive Data -	Receives data from connected device.	2	6
Transmit Data +	Transmits data to connected device.	3	1
Transmit Data -	Transmits data to connected device.	6	2
Protective Ground	Provides a path for the ground signal to an external single point ground.	Connector Shell	Connector Shell

Table 3-2: Digital Link Port Pin Assignments			
Pin	Label	In/Out	Connector Pinout
IN Connector			<p>RJ-45 Connectors</p>
1	Receive +	In	
2	Receive -	In	
3	Transmit +	Out	
4	Not Used	N/A	
5	Not Used	N/A	
6	Transmit -	Out	
7	Not Used	N/A	
8	Not Used	N/A	
Connector Shield	Provides a path for the ground signal to an external single point ground.	In	
OUT Connector			
1	Transmit +	Out	
2	Transmit -	Out	
3	Receive +	In	
4	Not Used	N/A	
5	Not Used	N/A	
6	Receive -	In	
7	Not Used	N/A	
8	Not Used	N/A	
Connector Shield	Provides a path for the ground signal to an external single point ground.	In	

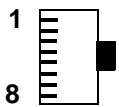
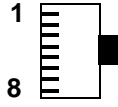
Table 3-3: Digital Link Port “IN” to “OUT” Cables				
Part Numbers: .3 M (1.0 ft): M.1302.8285 .6 M (2.0 ft): M.1302.8286 1 M (3.3 ft): M.1302.8287 2 M (6.6 ft): M.1302.8288 3 M (9.8 ft): M.1302.8289 5 M (16.4 ft): M.1302.8300 10 M (32.8 ft): M.1302.8301 15 M (49.2 ft): M.1302.8302 30 M (98.4 ft): M.1302.8303 Cable type: 28 AWG, shielded, twisted pair, 8 conductor.				
8-Pin RJ-45 Plug (to Digital Link Port “OUT”, face view) 		8-Pin RJ-45 Plug (to Digital Drive “IN”, face view) 		
Pin	Signal	Pin	Signal	Notes
1	Transmit Data +	1	Receive Data +	Twisted
2	Transmit Data -	2	Receive Data -	Pair
3	Receive Data +	3	Transmit Data +	Twisted
6	Receive Data -	6	Transmit Data -	Pair
4	None	4	None	Twisted
5	None	5	None	Pair
7	None	7	None	Twisted
8	None	8	None	Pair
Shell	Drain	Shell	Drain	

3.9.4 Power Input Connector

The 8-terminal Power Input Connector is used to bring User-provided System Power and Filed Power to the Slice I/O Coupler and attached Slice I/O Modules. This Removable Terminal Block is located at the left of the Coupler, as seen in [Figure 3-1 on page 14](#).

- Pin descriptions are provided in [Table 3-4](#)
- Pin assignments are provided in [Table 3-5](#)

Signal Type	Notes	Pins
SYS24V, SYS24COM	24 VDC input that provides System Power.	0,1
FLD24V, FLD24COM	24 VDC input that provides Field Power.	4,5,6,7
GND	Protective Ground. Must be connected to Protective Earth Ground (SPG)	2,3

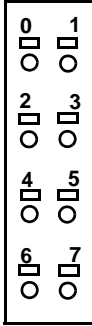
Pin	Signal	In/Out	Connector Pinout
0	System Power 24Vdc	In	8-pin cage-clamp connector (face view) 
1	System Power 24Vdc Common	In	
2	Chassis Ground	In	
3	Chassis Ground	In	
4	Field Power 24Vdc Common	In	
5	Field Power 24Vdc Common	In	
6	Field Power 24Vdc	In	
7	Field Power 24Vdc	In	

3.9.5 DC Input Connectors

Two connectors provide user access to the 16 fast DC Inputs provided on the Slice I/O Coupler. The two connectors are identical, and provide access to eight DC Inputs each. These Removable Terminal Blocks are located between the Power Input Connector and the DC Output Connectors, as seen in [Figure 3-1 on page 14](#).

Note that since the two DC Input connectors are identical, only one is described below.

- AT2-R833 Coupler Inputs (Sinking-type)

The inputs provided are Sinking-type. This means that when presented with a "high" signal state (Field Power 24Vdc), the input is Active. In addition, each input also has a corresponding Status LED associated with it, located above the Removable Terminal Block

For example, if a simple switch is being monitored by one of these inputs, connect one end of the switch to Field Power 24Vdc, and the other end of the switch to the desired input on the Removable Terminal Block. When the switch is open, the associated Status LED will be off, and the corresponding input bit, as read by the application program, will be low. When the switch is closed, the associated Status LED will be on, and the corresponding input bit, as read by the application program, will be high.

- AT2-R834 Coupler Inputs (Sourcing-type)

The inputs provided are Sourcing-type. This means that when presented with a "low" signal state (Field Power 24Vdc Common), the input is Active. In addition, each input also has a corresponding Status LED associated with it, located above the Removable Terminal Block

For example, if a simple switch is being monitored by one of these inputs, connect one end of the switch to Field Power 24Vdc Common, and the other end of the switch to the desired input on the Removable Terminal Block. When the switch is open, the associated Status LED will be off, and the corresponding input bit, as read by the application program, will be low. When the switch is closed, the associated Status LED will be on, and the corresponding input bit, as read by the application program, will be high.

- Pin descriptions are provided in [Table 3-6](#)
- Pin assignments are provided in [Table 3-7](#)

Signal Type	Notes	Pins
DCIN0 - DCIN7	AT2-R833: Sinking-type 24Vdc (nominal) inputs AT2-R834: Sourcing-type 24Vdc (nominal) inputs	0 - 7

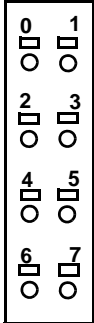
Table 3-7: DC Input Connector Assignment			
Pin	Signal	In/Out	Connector Pinout
0	DC Input 0	In	8-pin cage-clamp connector (face view) 
1	DC Input 1	In	
2	DC Input 2	In	
3	DC Input 3	In	
4	DC Input 4	In	
5	DC Input 5	In	
6	DC Input 6	In	
7	DC Input 7	In	

3.9.6 DC Output Connectors

Two connectors provide user access to the 16 fast DC Outputs provided on the Slice I/O Coupler. The two connectors are identical, and provide access to eight DC Outputs each. These Removable Terminal Blocks on the right side of the Coupler, as seen in [Figure 3-1 on page 14](#).

Note that since the two DC Output connectors are identical, only one is described below.

- AT2-R833 Coupler Outputs (Sourcing-type)

The Outputs provided are Sourcing-type. This means that when Active (written high by the application program), the Output is driven by Field Power 24Vdc. In addition, each Output also has a corresponding Status LED associated with it, located above the Removable Terminal Block

For example, if a simple light is being controlled by one of these outputs, connect one end of the light to Field Power 24Vdc Common, and the other end of the light to the desired output on the Removable Terminal Block. When the light is controlled off by the application program (written low), the associated Status LED will be off, and the light will be off. When the light is controlled on by the application program (written high), the associated Status LED will be on, and the light will be on.

- AT2-R834 Coupler Outputs (Sinking-type)

The Outputs provided are Sinking-type. This means that when Active (written high by the application program), the Output is driven by Field Power 24Vdc Common. In addition, each Output also has a corresponding Status LED associated with it, located above the Removable Terminal Block

For example, if a simple light is being controlled by one of these outputs, connect one end of the light to Field Power 24Vdc, and the other end of the light to the desired output on the Removable Terminal Block. When the light is controlled off by the

application program (written low), the associated Status LED will be off, and the light will be off. When the light is controlled on by the application program (written high), the associated Status LED will be on, and the light will be on.

- Pin descriptions are provided in [Table 3-8](#)
- Pin assignments are provided in [Table 3-9](#)

Signal Type	Notes	Pins
DCOUT0 - DCOUT7	AT2-R833: Sourcing-type 24Vdc (nominal) outputs AT2-R834: Sinking-type 24Vdc (nominal) outputs.	0 - 7

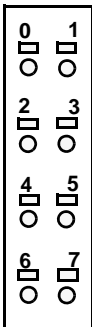
Pin	Signal	In/Out	Connector Pinout
0	DC Output 0	In	8-pin cage-clamp connector (face view) 
1	DC Output 1	In	
2	DC Output 2	In	
3	DC Output 3	In	
4	DC Output 4	In	
5	DC Output 5	In	
6	DC Output 6	In	
7	DC Output 7	In	

3.9.7 Slice I/O Coupler Wiring Examples

Refer to [Figure 3-3 on page 28](#) for an example of typical AT2-R833 Coupler I/O Wiring (Sinking Inputs, Sourcing Outputs). Refer to [Figure 3-4 on page 29](#) for an example of typical AT2-R834 Coupler I/O Wiring (Sourcing Inputs, Sinking Outputs).

Figure 3-3: AT2-R833 Slice I/O Coupler Wiring Example

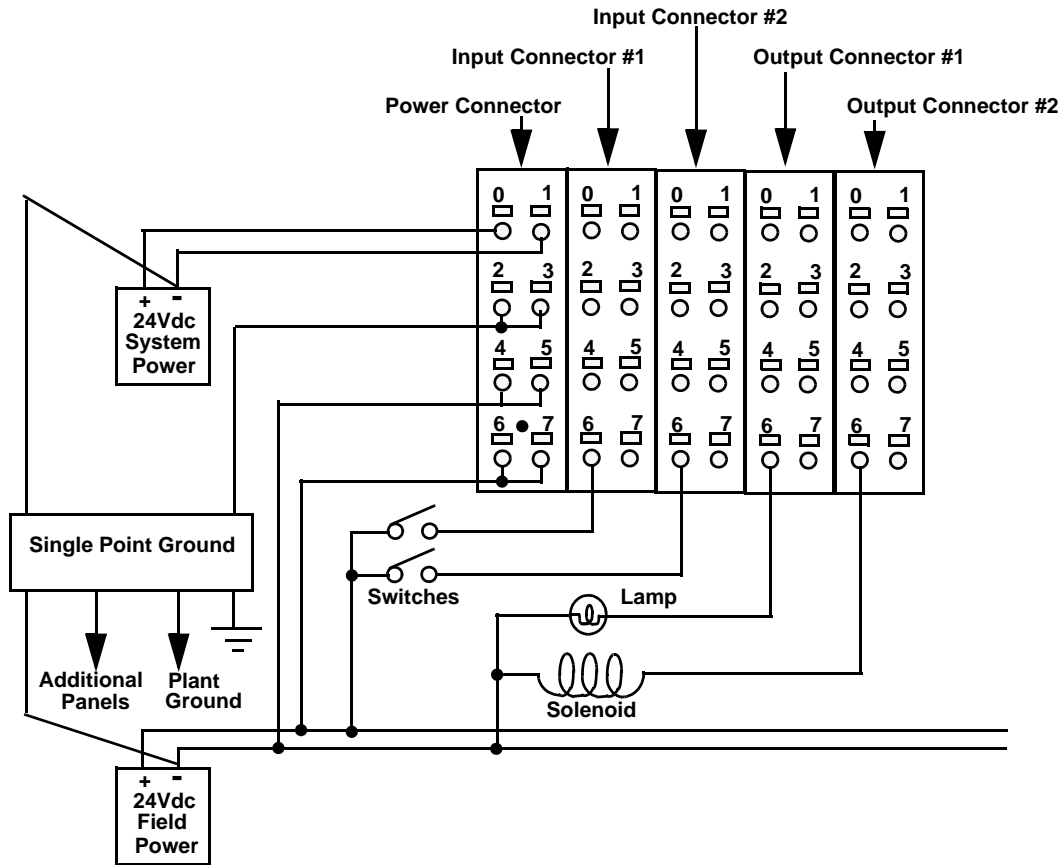
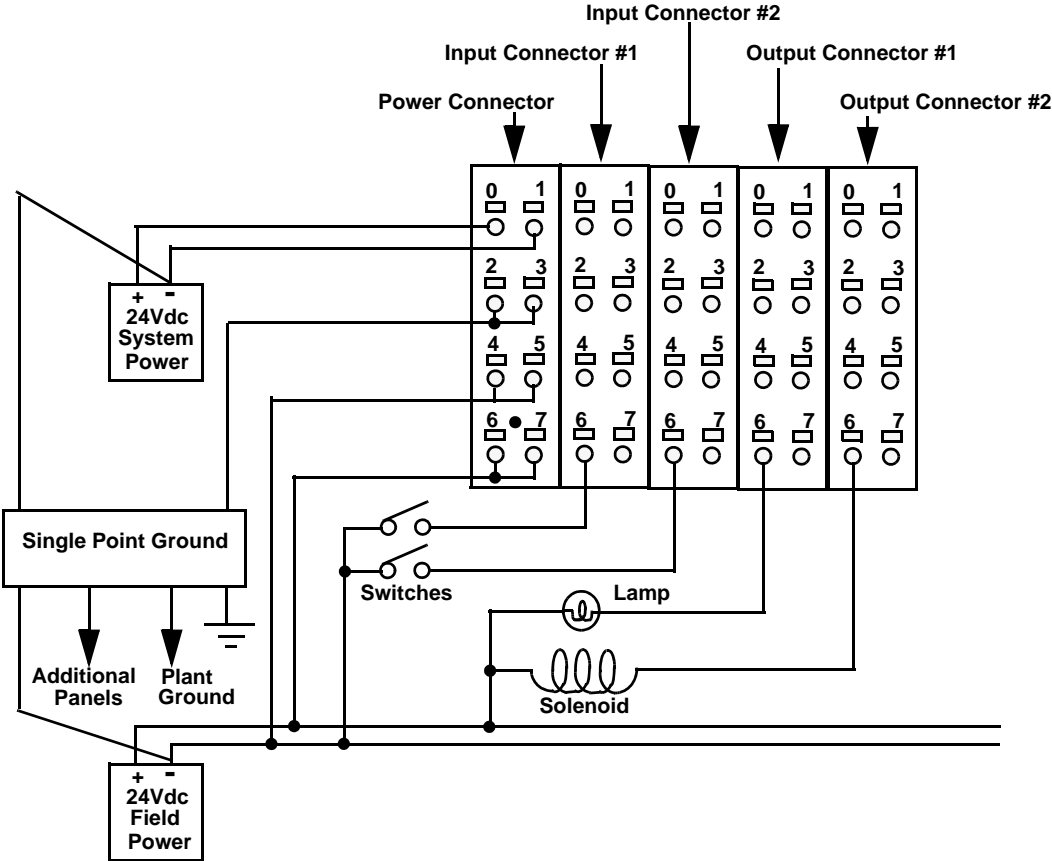

Figure 3-4: AT2-R834 Slice I/O Coupler Wiring Example



3.10 Slice I/O Modules

A wide variety of add-on Slice I/O Modules may be attached to the Slice I/O Coupler, including:

- DC and AC Input Modules
- DC, AC, and Relay Output Modules
- Analog Input Modules
- Analog Output Modules
- Power Supply and Power Distribution Modules

All Slice I/O Modules that will work with the Slice I/O Coupler are listed starting on [Table 3-10 on page 31](#).

3.10.1 Slice I/O Limitations and Precautions

When adding Slice I/O Modules, the following limitations and precautions must be observed:

- Each Slice I/O Module consumes a defined number of Input bytes and/or Output bytes (8 bits per byte). The Slice I/O Coupler supports a maximum of 16 Input bytes, and 16 Output bytes. The number of Input bytes and/or Output bytes that a particular module consumes is defined in the Module's data sheet.
- There are limitations to the amount of System Power that can be provided by the Slice I/O Coupler. Refer to [section 3.5.1 on page 15](#) for details.
- There are limitations to the amount of Field Power that can be provided through the Slice I/O Coupler. Refer to [section 3.5.2 on page 15](#) for details.
- Many Slice I/O modules require Field Power other than 24Vdc, such as 5Vdc, 48Vdc, or 110Vac. When switching between Field Power voltages, it is absolutely necessary to install an Expansion Field Power Distributor (P/N ST-7241) between the Modules. Refer to the ST-7241 Data Sheet for additional information.

WARNING

Failure to read and understand this section can result in damage to the entire Slice I/O System. This damage will not be covered under Kollmorgen's warranty policy.

3.10.2 Slice I/O Modules

All available Slice I/O Modules are listed in sections as follows:

- Digital Input Modules are listed in [Table 3-10 on page 31](#).
- Digital Output Modules are listed in [Table 3-11 on page 32](#).
- Analog Input Modules are listed in [Table 3-12 on page 33](#).
- Analog Output Input Modules are listed in [Table 3-13 on page 34](#).
- Power Modules are listed in [Table 3-15 on page 35](#).
- Accessory Parts are listed in [Table 3-16 on page 36](#).

Data sheets for each individual Module can be found at:

http://www.crevis.co.kr/eng/02_product/00_fnlo_s_series_overview.html

Table 3-10: Digital Input Slice I/O Modules	
Part Number	Description
ST-1114	4 Points, Sink, 5Vdc
ST-1124	4 Points, Source, 5VDC
ST-111F	16 Points, Sink, 5VDC ^{a,b}
ST-112F	16 Points, Source, 5VDC ^{a,b}
ST-1214	4 Points, Sink, 12V/24VDC
ST-1224	4 Points, Source, 12V/24VDC
ST-1218	8 Points, Sink, 12V/24VDC
ST-1228	8 Points, Source, 12V/24VDC
ST-121F	16 Points, Sink, 12V/24VDC ^b
ST-122F	16 Points, Source, 12V/24VDC ^b
ST-1314	4 Points, Sink, 48VDC
ST-1324	4 Points, Source, 48VDC
ST-131F	16 Points, Sink, 48VDC ^{a,b}
ST-132F	16 Points, Source ^{a,b}
ST-1804	4 Points, 110VAC
ST-1904	4 Points, 220VAC

a. Consult Factory for Availability

b. This module does not contain a Removable Terminal Block. Refer to [Table 3-16 on page 36](#) for available 20-pin mating connector

Table 3-11: Digital Output Slice I/O Modules	
Part Number	Description
ST-2114	4 Points, TTL Inverting, 5VDC/20mA
ST-2124	4 Points, TTL Non-Inverting, 5VDC/20mA
ST-2314	4 Points, Sink, 24VDC/0.5A
ST-2324	4 Points, Source, 24VDC/0.5A
ST-2414	4 Points, Sink, 24VDC/0.5A (with Diagnostic feedback)
ST-2424	4 Points, Source, 24VDC/0.5A (with Diagnostic feedback)
ST-2614	4 Points, Sink, 24VDC/2A
ST-2624	4 Points, Source, 24VDC/2A
ST-2514	4 Points, Sink, 24VDC/2A (with Diagnostic feedback)
ST-2524	4 Points, Source, 24VDC/2A (with Diagnostic feedback)
ST-2318	8 Points, Sink, 24VDC/0.5A
ST-2328	8 Points, Source, 24VDC/0.5A
ST-221F	16 Points, Sink, 24VDC/0.5A ^a
ST-222F	16 Points, Source, 24VDC/0.5A ^a
ST-2742	2 Points, Relay, 230VAC/2A, 24VDC/ 2A
ST-2792	2 Points, Source, 230Vac/2A, Manual Type ^{b,c}
ST-2744	4 Points, Relay, 230VAC/2A, 24VDC/ 2A
ST-2748	8 Points, Relay, 230VAC/2A, 24VDC/ 2A
ST-2852	2 Points, Triac, 120VAC/2A, 24VDC/2A

a. This module does not contain a Removable Terminal Block. Refer to [Table 3-16 on page 36](#) for available 20-pin mating connector

b. Consult Factory for Availability

c. Each output has an associated 3-position toggle switch, to allow the Output to be forced On, forced Off, or be controlled by the application

Part Number	Description
ST-3114	4 Channels, 0~20mA, 12Bit
ST-3134	4 Channels, 0~20mA, 14Bit
ST-3118	8 Channels, 0~20mA, 12Bit
ST-3214	4 Channels, 4~20mA, 12Bit
ST-3234	4 Channels, 4~20mA, 14Bit
ST-3218	8 Channels, 4~20mA, 12Bit
ST-3624	4 Channels, 0~5VDC, 12Bit
ST-3644	4 Channels, 0~5VDC, 14Bit
ST-3424	4 Channels, 0~10VDC, 12Bit
ST-3474	4 Channels, 0~10Vdc, 12Bit, Sensor Connector ^{a,b}
ST-3444	4 Channels, 0~10VDC, 14Bit
ST-3428	8 Channels, 0~10V, 12Bit
ST-3524	4 Channels, -10~+10VDC, 12Bit
ST-3544	4 Channels, -10~+10VDC, 14Bit
ST-3702	2 Channels, RTD
ST-3704	4 Channels, RTD ^{b,c}
ST-3708	8 Channels, RTD ^{b,c}
ST-3802	2 Channels, Thermocouple
ST-3804	4 Channels, Thermocouple ^{b,c}
ST-3808	8 Channels, Thermocouple ^{b,c}

a. This module does not contain a Removable Terminal Block, and requires two 4-pin 3M 37104-series mini-clamp plugs for field-side connection

b. Consult Factory for Availability

c. This module does not contain a Removable Terminal Block. Refer to [Table 3-16 on page 36](#) for available 20-pin mating connector

Table 3-13: Analog Output	
Part Number	Description
ST-4112	2 Channels, 0~20mA, 12Bit
ST-4114	4 Channels, 0~20mA, 12Bit
ST-4274	4 Channels, 4~20mA, 12Bit, Sensor Connector ^{a,b}
ST-4212	2 Channels, 4~20mA, 12Bit
ST-4214	4 Channels, 4~20mA, 12Bit
ST-4622	2 Channels, 0~5V, 12Bit
ST-4422	2 Channels, 0~10V, 1
ST-4491	1 Channel, 0~10V, 12Bit, Manual Type ^{b, c}
ST-4424	4 Channels, 0~10V, 12Bit
ST-4474	4 Channels, 0~10V, 12Bit, Sensor Connector ^{a,b}
ST-4522	2 Channels, -10~+10VDC, 12Bit

a. This module does not contain a Removable Terminal Block, and requires two 4-pin 3M 37104-series mini-clamp plugs for field-side connection

b. Consult Factory for Availability

c. The output has an associated 2-position toggle switch, to allow the Output to be controlled by the front-panel potentiometer, or be controlled by the application

Table 3-14: Special Modules	
Part Number	Description
ST-5101	1 Channel, High Speed Counter, 5VDC
ST-5111	1 Channels, High Speed Counter, 24VDC
ST-5112	2 Channels, High Speed Counter, 24VDC ^a
ST-5114	4 Channels, High Speed Counter, 24Vdc
ST-5442	2 Channels, PWM Source Output, 0.5A/24VVDC ^a
ST-5422	2 Channels, PWM Source Output, 1.5A/24VVDC ^a
ST-5444	4 Channels, PWM Source Output, 1.5A/24VDC ^a
ST-5641	1 Channel, Pulse Source Output, 0.5A/24VDC ^a
ST-5642	1 Channel, Pulse Source Output, 0.5A/24VDC ^a

a. Consult Factory for Availability

Table 3-15: Power Modules	
Part Number	Description
ST-7111	Expansion Power Supply (Input 24VDC/Output 1.0A/5VDC)
ST-7241	Expansion Field Power Distributor
ST-7008	Potential Distributor, for Shield
ST-7108	Potential Distributor, for 0VDC
ST-7118	Potential Distributor, for 24VDC
ST-7188	Potential Distributor, for 24VDC and 0VDC

Table 3-16: Accessory Parts	
Part Number	Description
ST-END	End Cover
ST-8121	End Cover, package of 7
ST-NUM-0-9	Numbering, 0~9, White
ST-8371	Numbering, 0~9, White, package of 100
ST-NUM-BLANK	Numbering, Blank
ST-8372	Numbering, Blank, package of 100
ST-RTB	Removable Terminal Block
ST-8241	Removable Terminal Block, package of 9
M.3000.0983	20-pin, MOD IV connector for use with 16-point I/O modules. (AMP P/N 102387-4)
M.1007.1152	Crimp-type MOD IV pins for use with M.3000.0983. (AMP P/N 87046-3)
M.1300.0593	MOD IV Crimper for use with M.1007.1152 pins. (AMP P/N 90202-2)

3.11 Slice I/O Coupler Specifications

Part number	AT2-R833 AT2-R834
Digital Link Ports	IEEE 802.3/802.3u-100Base-TX Cable type: Shielded, Straight Pinned, CAT5 or better (CAT5e, CAT6, etc.) Maximum cable length: 30 M (98.4 ft)
System Power Input	24Vdc (nominal), 20 VDC to 30 VDC, .5A Maximum
System Power Output	5Vdc (nominal), 1A Maximum (to connected Modules)
Field Power Input	24Vdc (nominal), 11Vdc to 28.8Vdc, 10A Maximum (dependent on current used for connected I/O)
Operating temperature range	5°C to 55°C (41°F to 131°F)
Storage temperature range	-40°C to 85°C (-40°F to 185°F)
Humidity	5 to 90%, non-condensing
CE Marked (Pending)	<p>Conforms to Directives 73/23/EEC, 89/336/EEC, 92/31/EEC, 93/68/EEC by conforming to the following standards: EN 50081-2:1993EMC Generic Industrial Emissions EN 50082-2:1995EMC Generic Industrial Immunity EN 61131-2:1994/A11:1996 Low voltage directive requirements for programmable controllers Operates with emissions below EN55011/ CISPR 11 Class A limits Immune to:</p> <ul style="list-style-type: none"> • Electrostatic discharge (4K V contact mode, 8K V air discharge) per EN61000-4-2 • RF electromagnetic fields per EN61000-4-3, ENV 50141, and ENV50204 • Electrical fast transients per EN61000-4-4 • Magnetic fields per EN61000-4-8 <p>Refer to the EMC Guidelines for more information.</p>
UL and C/UL Listed	UL File E235505
Physical size	3.27" wide x 3.90" high x 2.76" deep 83 mm x 99 mm x 70 mm
Vibration	10-57 Hz (.012in peak-to-peak) 57 - 500 Hz (acceleration = 2 g)
Shock	10g

DC Inputs	
Number of Inputs	16
Configuration	AT2-R833: Sinking only AT2-R834: Sourcing only
Input voltage	Nominal 24 VDC, maximum 28.8 VDC
Input current	4.5 mA at 24 VDC, typical
Guaranteed on voltage	AT2-R833: 11 VDC (Minimum) AT2-R834: 5 VDC (Maximum)
Guaranteed off voltage	AT2-R833: 5 VDC (Maximum) AT2-R834: 11 VDC (Minimum)
Turn on/off time	500 us
General DC Outputs	
Number of outputs	16
Configuration	AT2-R833: Sourcing only AT2-R834: Sinking only
Operating voltage	Nominal 24 VDC (11 VDC Min, 28.8 VDC Max)
Protection of logic circuits	Optical isolation between the logic and field side
Maximum current	.5 A per output (8A total)
Switch characteristics	Solid-state switches
Time delay on for resistive loads	300 µsec max
Time delay off for resistive loads	300 µsec max
Leakage current in off state	50 uA max
Voltage drop (Output ON)	.3 VDC max
Over-current protection	Yes
Short circuit protection	Yes
Scan loss response	Outputs turn off

4 **Digital Link Drive Interface Unit**

This document contains Beta connection information on the Digital Link Drive Interface Unit (DL-DIU).

CE ENCLOSURE REQUIREMENTS

In order to meet the requirements of the CE Directives, the DL-DIU must be mounted within a grounded metal enclosure. Additional actions may also be required, as described elsewhere within this manual.

Figure 4-1:

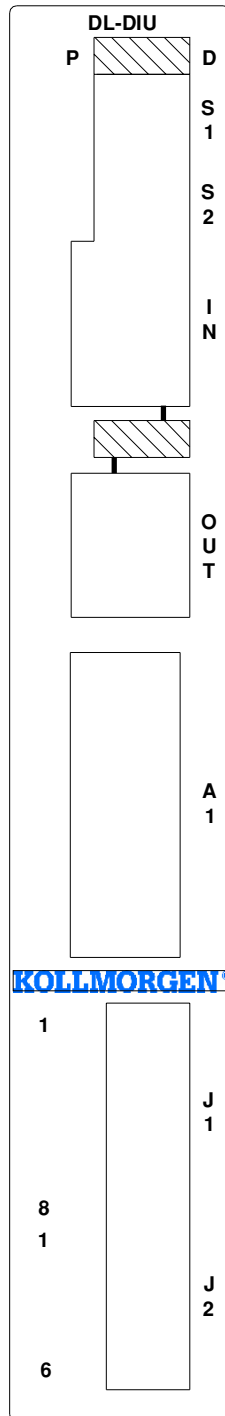

4.1 DL-DIU Front Panel Details

This section explains in detail the various indicators and connectors located on the DL-DIU.

4.1.1 LED Indicators

There are four LED Indicators on the front of the DL-DIU, as described in [Table 4-1](#).

LED	Color	Description
Power	Green	The Power LED (labeled "P" on the front of the unit), located at the top of the DL-DIU, indicates the condition of incoming 24Vdc power.
Diagnostic	Yellow	The Diagnostic LED (labeled "D" on the front of the unit), located in the top of the DL-DIU, serves as the Status indicator, and provides DL-DIU status and fault information.
Digital Link LEDs	Green	These LEDs, located between the "IN" and "OUT" connectors, provide Digital Link status information.

4.1.2 Power Indicator Details

The green Power Indicator LED (P) indicates that the power supplies internal to the DL-DIU are working properly. If the Power LED (P) does not go on, or goes off during operation of the unit, check that the proper voltage is present at the DL-DIU power connector. If it is, turn off the main disconnect switch and replace the DL-DIU.

4.1.3 Diagnostic Indicator Details

The Diagnostic Indicator LED (labeled "D" on the front of the DL-DIU) performs various functions:

- When Control Power is applied to the DL-DIU, the Diagnostic LED turns on briefly as the DL-DIU runs internal power-on diagnostics. If the diagnostics pass, the Diagnostic LED goes off.
- If the Diagnostic LED is flashing after the power-on diagnostics are complete, there is a problem with the DL-DIU.
- While the DL-DIU is operating, operation and performance are constantly monitored. If a Warning or Fault condition is detected, the Diagnostic LED will blink.

4.1.4 Digital Link LEDs

There are two green LED indicators located between the Digital Link "IN" and "OUT" connectors.

- The right-most LED is associated with the "IN" connector, and indicates that the DL-DIU is connected and successfully communicating with another "upstream" device (either a Digital Link drive, Control, or Accessory).

- The left-most LED is associated with the "OUT" connector, and indicates that the DL-DIU is connected and successfully communicating with another "downstream" device (either a Digital Link drive or Accessory).

4.1.5 Node Address Rotary Switches

Two rotary switches are used to set the DL-DIU address on the Digital Link. Rotate the switch to the desired address.

Addresses can be set to any number from 1 through 64. The top switch represents values of base ten. The bottom switch represents values of base 1.

As an example, rotating the top switch (S1) to a setting of 2 equals the value of 20 (2 x 10). Rotating the bottom switch (S2) to a setting of 5 equals the value of 5. The actual address setting is 25 (20 + 5).

Figure 4-2: Node Address Switches

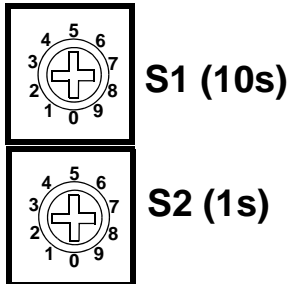

4.1.6 Digital Link Ports

The two 8-pin RJ-45 Digital Link Port connectors (labeled “IN” and “OUT” on the front of the DL-DIU) provide communications between the DL-DIU and:

- a Digital Link drive (MMC Smart Drive or S200-DLS Drive)
- a Digital Link Accessory (Slice I/O Coupler or another DL-DIU)
- an MMC-DSA Control (MMC-DSA2, -DSA4, -DSA8, -DSA16)
- a Digital Standalone MMC Control (MMC-D32, -D64)

Also provided are two green “Link” lights located between the RJ-45 connectors. The right light will be on if there is a Digital Link Device connected to the “IN” port, and the left light will be on if there is a Digital Link Device connected to the “OUT” port.

A “straight-through” shielded cable must be used when connecting to and from other devices. Connect the cable from the DL-DIU’s “OUT” port to the next Digital Link Device’s “IN” port, and from the previous Digital Link Device’s “OUT” port to the DL-DIU’s “IN” port. Refer to the Standalone MMC Hardware Manual for Standalone Digital Control information.

- Pin descriptions for are provided in [Table 4-2](#)
- Pin assignments are provided in [Table 4-3](#)
- The available Digital Link Port to Digital Drive cables are described in [Table 4-4](#)

Table 4-2: Digital Link Port Pin Description

Digital Link Connector (IN/OUT) Signals		Pin	
Function	Notes	“In” Connector	“Out” Connector
Receive Data+/-	Receives data from connected devices.	1,2	3,6
Transmit Data +/-	Transmits data to connected devices.	3,6	1,2
Protective Ground	Shield connection. Provides a path for the ground signal to an external single point ground.	Connector Shell	Connector Shell

Table 4-3: Digital Link Port Pin Assignments

Pin	Label	In/Out	Connector Pinout
IN Connector			<p>RJ-45 Connectors</p>
1	Receive +	In	
2	Receive -	In	
3	Transmit +	Out	
4	Not Used	N/A	
5	Not Used	N/A	
6	Transmit -	Out	
7	Not Used	N/A	
8	Not Used	N/A	
Connector Shield	Provides a path for the ground signal to an external single point ground.	In	
OUT Connector			
1	Transmit +	Out	
2	Transmit -	Out	
3	Receive +	In	
4	Not Used	N/A	
5	Not Used	N/A	
6	Receive -	In	
7	Not Used	N/A	
8	Not Used	N/A	
Connector Shield	Provides a path for the ground signal to an external single point ground.	In	

Table 4-4: Digital Link Port “IN” to “OUT” Cables

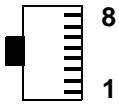
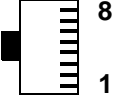
Table 4-4: Digital Link Port “IN” to “OUT” Cables				
Part Numbers: .3 M (1.0 ft): M.1302.8285 .6 M (2.0 ft): M.1302.8286 1 M (3.3 ft): M.1302.8287 2 M (6.6 ft): M.1302.8288 3 M (9.8 ft): M.1302.8289 5 M (16.4 ft): M.1302.8300 10 M (32.8 ft): M.1302.8301 15 M (49.2 ft): M.1302.8302 30 M (98.4 ft): M.1302.8303 Cable type: CAT-5 (or better), 28 AWG, shielded, twisted pair, 8 conductor.				
8-Pin RJ-45 Plug (to Digital Link Port “OUT”, face view) 		8-Pin RJ-45 Plug (to Digital Port “IN”, face view) 		
Pin	Signal	Pin	Signal	Notes
1	Transmit Data +	1	Receive Data +	Twisted Pair
2	Transmit Data -	2	Receive Data -	
3	Receive Data +	3	Transmit Data +	Twisted Pair
6	Receive Data -	6	Transmit Data -	
4	None	4	None	Twisted Pair
5	None	5	None	
7	None	7	None	Twisted Pair
8	None	8	None	
Shell	Drain	Shell	Drain	

4.1.7 Axis I/O Port

The 15-pin HD female D-sub Axis I/O Port connector (labeled “A1” on the front of the DL-DIU) provides connection between the DL-DIU and an analog drive by providing the following:

- Two 24 Vdc outputs, described in detail in [section 4.1.7.1 on page 49](#).
- One DC input, described in detail in [section 4.1.7.2 on page 51](#).
- One 16-bit resolution analog output, described in detail in [section 4.1.7.3 on page 52](#).
- One quadrature, incremental encoder input, described in detail in [section 4.1.7.4 on page 53](#).

Additional information is provided in this section as follows:

- Pin descriptions provided in [Table 4-5](#)
- Pin assignments are provided in [Table 4-6](#)
- The available Flying Lead cable is described in [Table 4-7](#).
- Available Breakout Boxes and Cables are described in [Table 4-8](#).
- Breakout Box dimensions are shown in [Figure 4-3](#)

Table 4-5: Axis I/O Port Pin Descriptions

Function	Notes	Pin
Encoder Input (A, A/, B, B/, I, I/)	Provides connections to an incremental encoder having differential outputs.	1-5, 10
D/A Output (DA+, DA-)	+/- 10V D/A output for controlling an analog drive having a differential input.	8, 9
DC Input (DCIN+, DCIN-)	Provides connection to an input device (sink or source).	6, 7
DC Outputs (DCOUT1, DCOUT2)	Provides connection to an output device (sink or source).	13, 14
DCOSS	Connect this pin to +24 Vdc to configure the outputs (DCOUT1 & DCOUT2) as sinking-type, and to +24 Vdc Common to configure the DC Outputs (DCOUT1 & DCOUT2) as sourcing-type.	15
24 Vdc out	24 Vdc output to be used to power connected input and/or output devices.	11
COM	24 Vdc Common used to provide the 24 Vdc return path for sinking-type outputs.	12
Shield Ground	Provides a path for shield current through the chassis to an external single point ground.	Shell

Table 4-6: Axis I/O Port Pin Assignments			
Pin	Signal	In/Out	Connector Pinout
1	A	In	<p>15-pin HD female D-sub</p> 
2	A/	In	
3	B	In	
4	B/	In	
5	I	In	
6	DCIN+	In	
7	DCIN-	Out	
8	D/A+	Out	
9	DA-	Out	
10	I/	In	
11	+24 Vdc	Out	
12	COM	In	
13	DCOUT1	In/Out	
14	DCOUT2	In/Out	
15	DCOSS	In/Out	
Connector Shell	Drain	In	

Table 4-7: Axis I/O Port to Flying Lead Cable

Part Number: M.3000.1057
 Length: 3 M (10 ft)
 Cable type: 28 AWG (1 pair 16 AWG), shielded, twisted pair, 18 conductor.

15-Pin HD male D-sub (to Axis I/O Port, face view)

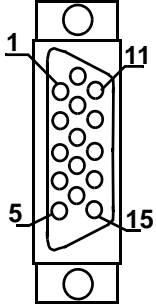
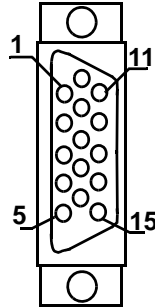

Pin	Signal	Color	Notes
1	A	Yellow	Twisted
2	A/	White/Yellow	Pair
3	B	Blue	Twisted
4	B/	White/Blue	Pair
5	I	Black	Twisted
10	I/	White/Black	Pair
8	D/A+	Violet	Twisted
9	D/A -	White/Violet	Pair
6	DCIN+	Red	Twisted
7	DCIN-	White/Red	Pair
13	DCOUT1	Green	Twisted
14	DCOUT2	White/Green	Pair
15	DCOSS	Brown	Twisted
NC	N/A	White/Brown	Pair
11	+24 Vdc (16 AWG)	Gray	Twisted
12	+Com (16 AWG)	White/Gray	Pair
Shell	Drain	N/A	

Table 4-8: Axis I/O Port Connection Accessories		
Description	Length	Part Number
Axis I/O Port Breakout Board ^a	N/A	M.1302.6970
Axis I/O Port Breakout Box ^b	N/A	M.1016.2529
Axis I/O Port Breakout Box Cable	.3 M (1 ft)	M.3000.1058
Axis I/O Port Breakout Box Cable	.6 M (2 ft)	M.3000.1059
Axis I/O Port Breakout Box Cable	.9 M (3 ft)	M.3000.1060

- a. The Breakout Board is mounted directly onto the Axis I/O Port Connector, and provides screw terminal wire termination to each of the Axis I/O Connector's signal pins as well as to the shell of the connector.
- b. The Breakout Box (see [Figure 4-3 on page 49](#)) is DIN-rail mounted, and provides screw terminal wire termination. It can be attached to the A1 port on the DL-DIU. The pinouts on the terminal strip interface provide a one-to-one transfer of the signals from the connector to the respective pin(s) on the terminal block. The ground pin on the terminal strip provides a connection to the metal D-shell.

Figure 4-3: Axis I/O Port Breakout Box Dimensions

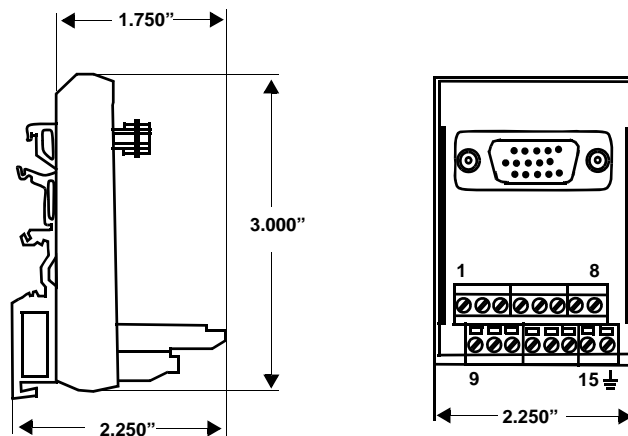

4.1.7.1 Axis I/O Port DC Outputs

The Axis I/O Port provides 2 sink or source 24 Vdc outputs. Each of the 2 outputs consists of an optically isolated solid state switch rated at 100 ma. It turns on or off according to the logic state sent to it by the user program. When the switch turns on, current flows through the switch. When the switch turns off, current flow stops. When the DCOSS pin is tied to the +24V, the outputs will be in a source configuration as

shown in [Figure 4-4](#). When the DCOSS pin is tied to COMMON, the outputs will be in a sink configuration as shown in [Figure 4-5](#).

These outputs are intended to interface with the drive enable and drive reset inputs.

For safety reasons, all outputs turn off (no current flow) when a scan loss condition occurs.

For more information on DC output operation, refer to [Section 6.3 on page 76 of Appendix A](#).

Figure 4-4: Axis I/O DC Output Source Configuration

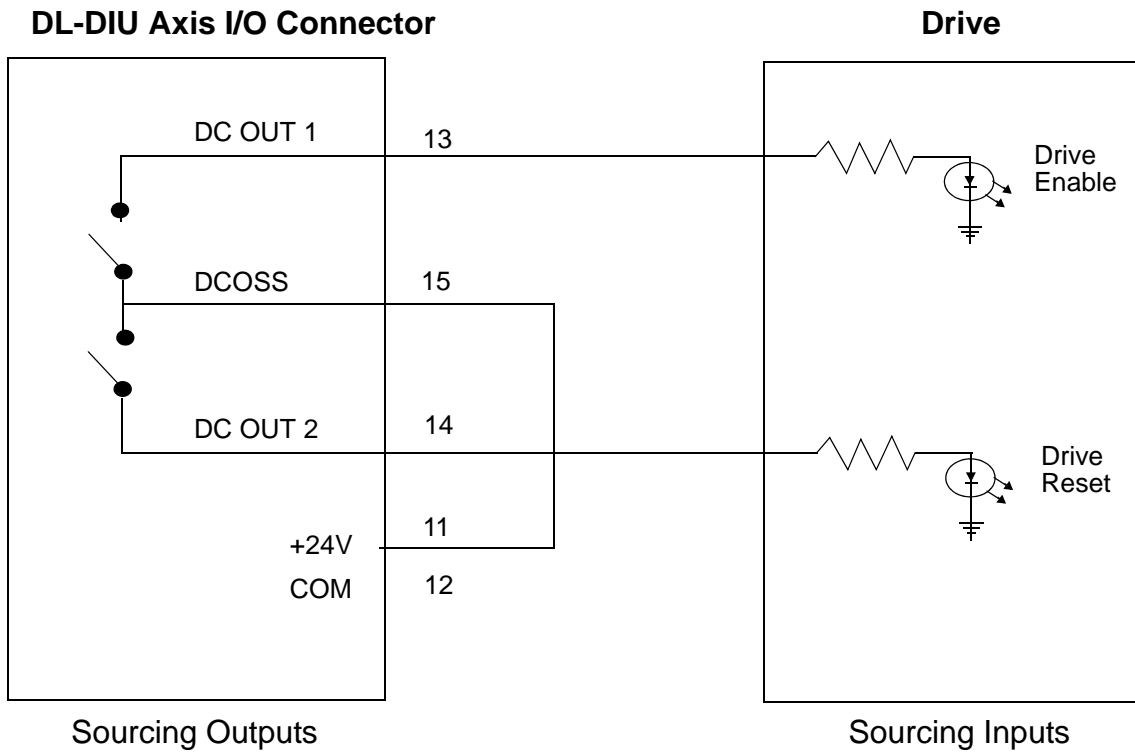
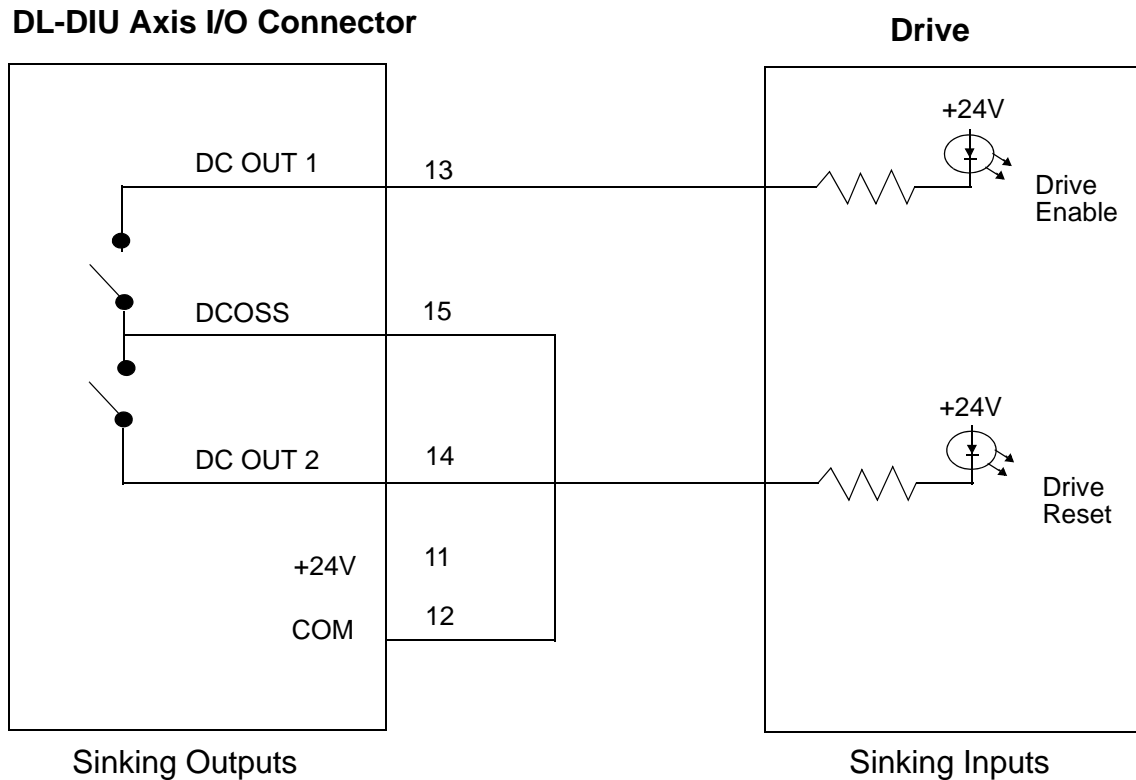

Figure 4-5: Axis I/O DC Output Sink Configuration



4.1.7.2 Axis I/O Port DC Input

The Axis I/O Port provides one 24 Vdc input. This input consists of an optically isolated solid state switch that can be wired in either a sourcing or sinking configuration. The input is turned on or off by the connected external device. One of the input pins should be connected to either +24 Vdc or COM. The remaining input pin should be tied to the input device. Refer to [Figure 4-6](#).

This input is intended to interface with the drive ready output.

For more information on DC input operation, refer to [Section 6.2 on page 75 of Appendix A](#).

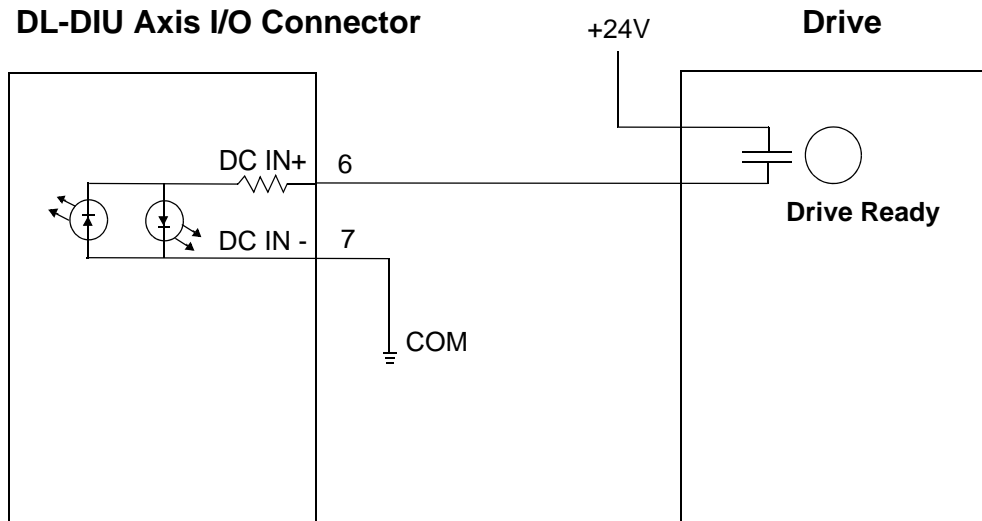
Figure 4-6: Axis I/O Port DC Input

4.1.7.3 Axis I/O Port Analog Output

The Axis I/O Port provides a ± 10 V differential Analog Output. The Analog Output is typically connected to the drive Command Input. Only shielded twisted pair wire should be used to make the connection between the analog output and the drive as shown in [Figure 4-7](#).

The application program sends the analog output section a 16-bit digital word to the analog output. This digital word is converted to a corresponding voltage within the range of ± 10 Vdc. The voltage is buffered and brought out to a pair of I/O connections as a differential type voltage output. This output is less subject to interference from electrical noise than a single-ended output would be.

You can adjust each analog output channel in software for offset adjustments, gain scaling, and unipolar outputs.

For safety reasons, all outputs are automatically reset to 0 Vdc when a scan loss condition occurs.

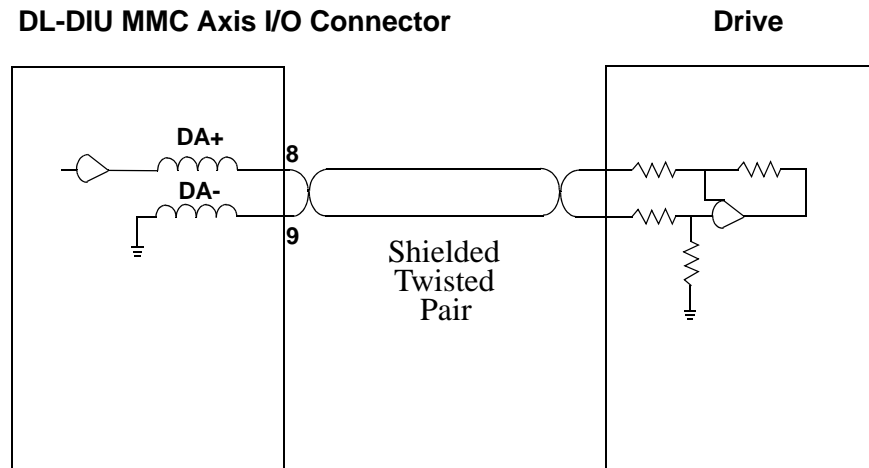
Figure 4-7: Axis I/O Port D/A Output

4.1.7.4 Axis I/O Port Encoder Input

The Axis I/O Port provides an input for a differential incremental encoder. The encoder output signals from the drive should be connected to the Axis I/O Port encoder input for each axis. The Axis I/O Port encoder input accepts RS422 differential inputs. The encoder signals should be quadrature type. All encoder wiring between the DL-DIU and the drive should be shielded twisted pair as shown in [Figure 4-8](#).

For more information on the Encoder input operation, refer to [Section 6.4 on page 77 of Appendix A](#).

NOTE

The power supply that powers the encoder must be referenced to the power supply that powers the DL-DIU. This is done by connecting the "common" terminal of each supply back to Single Point Ground. Failure to observe this precaution may result in sporadic encoder operation and/or damage to the DL-DIU.

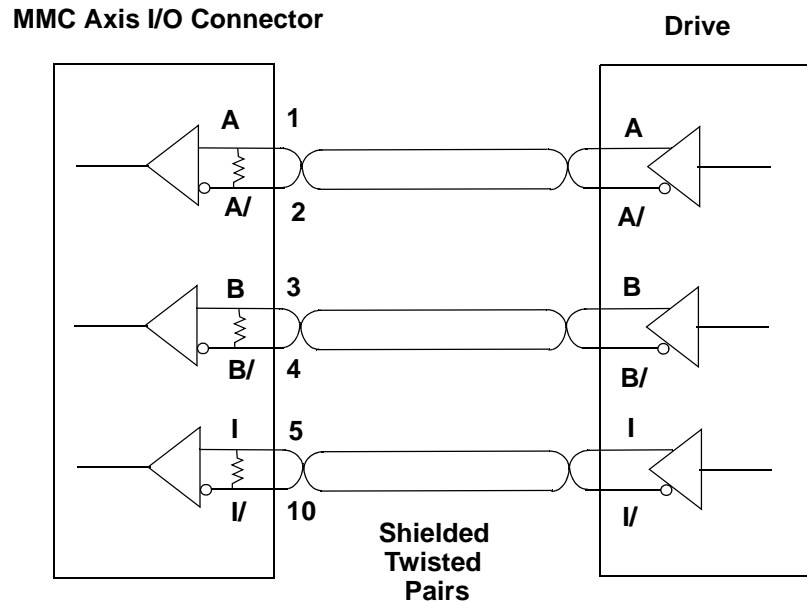
Figure 4-8: Axis I/O Port MMC Encoder Input

4.1.8 I/O and Power Ports

The 8-pin pluggable spring-terminal I/O Port connector (labeled "J1" on the front of the DL-DIU) provides connection between user I/O devices and the DL-DIU. The I/O port contains one sink or source (selectable) input (described in detail in [section 4.1.9.1 on page 56](#)), and one Analog Input (described in detail in [section 4.1.9.2 on page 57](#)).

The 6-pin pluggable spring-terminal Power Port connector (labeled "J2" on the front of the DL-DIU) provides power to the DL-DIU and to the I/O.

- Pin descriptions for the I/O Port are provided in [Table 4-9](#), and for the Power Port in [Table 4-10](#).
- Pin assignments for the I/O Port are provided in [Table 4-11](#), and for the Power Port in [Table 4-12](#).
- The available I/O Port and Power Port Accessories are described in [Table 4-13](#).
- The I/O Port is discussed in more detail in [section 4.1.9 on page 56](#).

Table 4-9: I/O Port (J1) Pin Descriptions		
Function	Notes	Pin
DC Input 1	24 Vdc (nominal) sourcing/sinking Inputs	5
Analog Input	+/- 10V, 1mv resolution	6,7
Reserved for future use. Do not connect	These pins will provide future functionality.	1,2,3,4,8

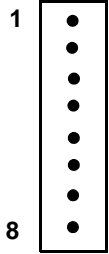
Table 4-10: I/O Port Pin Assignments			
Pin	Signal	In/Out	Connector Pinout
1	Do Not Connect	N/A	8-Pin plugable Screw Terminal Connector 
2	Do Not Connect	N/A	
3	Do Not Connect	N/A	
4	Do Not Connect	N/A	
5	DC Input 1	In	
6	Analog Input +	In	
7	Analog Input -	In	
8	Do Not Connect	N/A	

Function	Notes	Pin
I/O 24V Power	24Vdc (nominal) to power the DL-DIU and the I/O	4
I/O 24V Common	I/O 24V common	5
DC Input 1 Sink/source	This pin determines whether I/O input 1 is sourcing (this pin connected to 24 Vdc Common) or sinking (this pin connected to 24 Vdc)	1
Chassis Ground	This pin should be connected to Chassis Ground	6

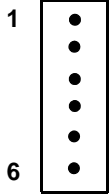
Pin	Signal	In/Out	Connector Pinout
1	Input 1 Sink/Source	In	6-Pin pluggable Screw Terminal Connector 
2	Do not Connect	N/A	
3	Do Not Connect	N/A	
4	I/O 24 Vdc	N/A	
5	I/O 24 Vdc Common	In	
6	Chassis Ground	In	

Description	Part Number
6-pin spring-contact pluggable mating connector for the I/O Power Port (J2)	M.1302.7662
8-pin spring-contact pluggable mating for connector for the I/O Port (J1)	M.1302.7627

4.1.9 I/O Port Details

There is one DC Input and one analog Input available for interfacing to various devices. This section explains these Inputs in detail.

4.1.9.1 I/O Port Input

The I/O Port provides one sink/source 24 Vdc input.

To configure the Input as Sinking, the Sink/Source select pin (pin 1), must be connected to 24 Vdc. When configured as Sinking, one side of the input device is connected to the Input pin on the I/O Port connector, and the other side of the input device must be connected to 24 Vdc Common.

To configure an Input as Sourcing, the Sink/Source select pin (pin 1), must be connected to 24 Vdc Common. When configured as Sourcing, one side of the input device is connected to the Input pin on the I/O Port connector, and the other side of the input device must be connected to 24 Vdc.

4.1.9.2 Analog Input

The I/O Port provides one differential analog input channel. The input range is ± 10 VDC (nominal), with 1mv resolution. The analog input voltage is sampled every 125 μ sec and the 16-bit result is stored in an on-board register. This register can be read at any time by the application.

The analog input signal passes through a common mode and differential mode filter prior to being applied to the A/D converter. These filters improve the noise immunity of the converter.

4.1.9.3 I/O Port Wiring Example

An example of wiring the I/O is shown in [See Figure 4-9 on page 58](#).

- The Sink/Source select pin for Input 1 on the I/O Power Port connector is connected to 24 Vdc, making Inputs 1 Sinking. In this configuration, one side of the input device is connected to the Input pin on the I/O Port connector, and the other side of the input device is connected to 24 Vdc Common.

Figure 4-9: Connecting Devices to the I/O Port

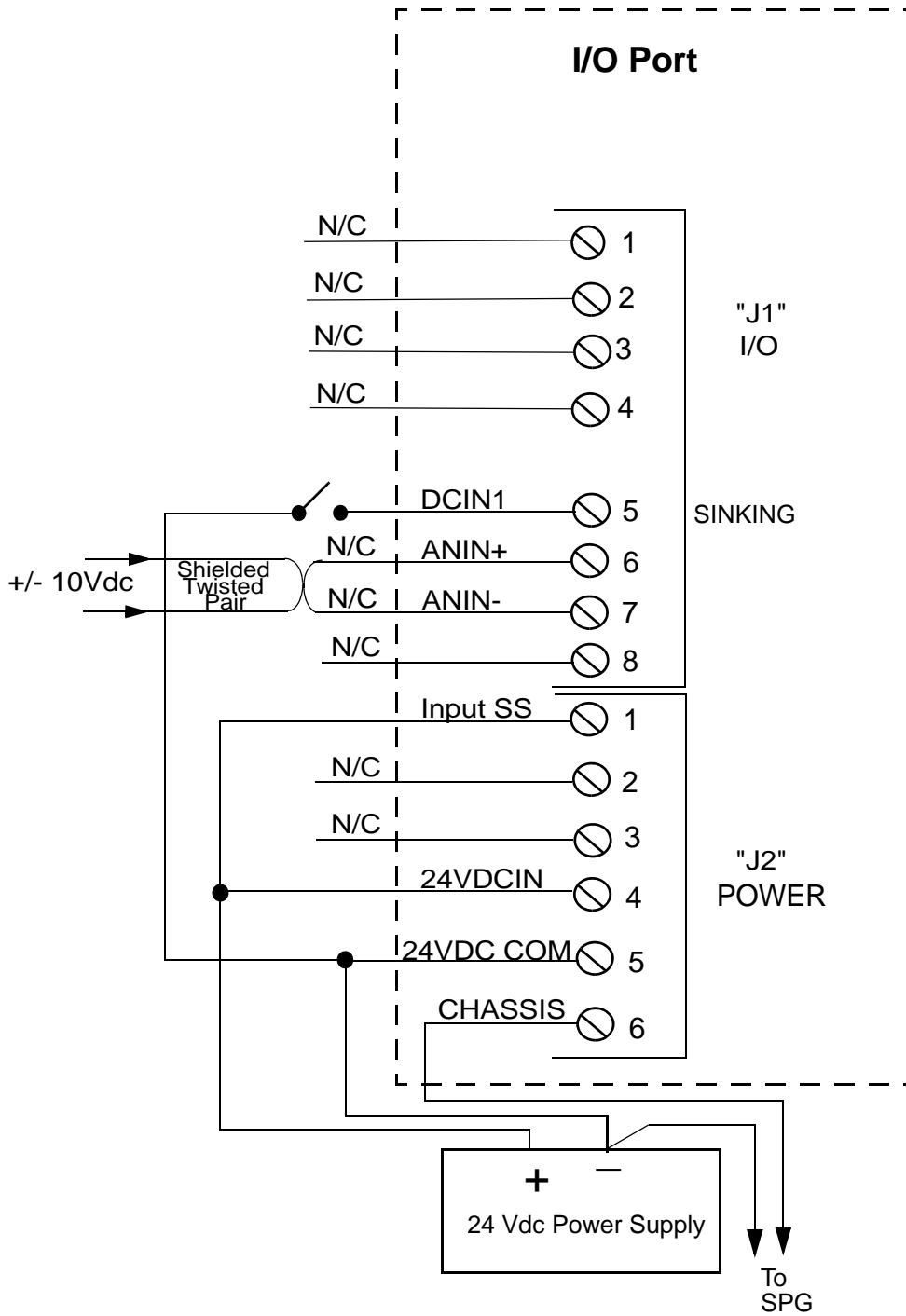

4.2 Specifications

Table 4-14: DL-DIU Specifications	
Function	<ul style="list-style-type: none"> • Provides Digital Link control of an Analog Drive • Provides a +/-10Vdc Analog Input
Part Number	M.3000.0832
Input voltage	20 VDC to 30 VDC
Input power	100ma typical
Operating temperature range	5°C to 55°C (41°F to 131°F)
Storage temperature range	-40°C to 85°C (-40°F to 185°F)
Humidity	5 to 95%, non-condensing
CE Marked (Pending)	<p>Conforms to Directives 73/23/EEC, 89/336/EEC, 92/31/EEC, 93/68/EEC by conforming to the following standards: EN 50081-2:1993EMC Generic Industrial Emissions EN 50082-2:1995EMC Generic Industrial Immunity EN 61131-2:1994/A11:1996 Low voltage directive requirements for programmable controllers Operates with emissions below EN55011/ CISPR 11 Class A limits Immune to:</p> <ul style="list-style-type: none"> • Electrostatic discharge (4K V contact mode, 8K V air discharge) per EN61000-4-2 • RF electromagnetic fields per EN61000-4-3, ENV 50141, and ENV50204 • Electrical fast transients per EN61000-4-4 • Magnetic fields per EN61000-4-8 <p>Refer to the EMC Guidelines for more information.</p>
UL and C/UL Listed	E126417
Physical size	1.125" wide x 6.0" high x 4.0" deep 28.57 mm x 152.4 mm x 101.6 mm
Vibration (per IEC 68-2-6)	10-57 Hz (constant amplitude = .15 mm) 57 - 2000 Hz (acceleration = 2 g)
Shock (per IEC 68-2-27)	Four shocks per axis (15g/11 msec)

Axis Port Analog Output	
Output channels	1
Resolution	16 bits
Output voltage range	± 10 VDC
Maximum output current (1K Ω load)	± 10 mA
Power on output voltage	0 V ± 100 mV
Scan loss output voltage	0V ± 100 mV
Accuracy	$\pm 0.375\%$ of FSR Drift ± 50 ppm/ $^{\circ}$ C
Update rate	125 μ sec
Axis Port Encoder Input	
Input channels	1
Input receiver	Maxim 3098 A quad B differential RS422 receiver
Recommended Encoder Drivers	7272, 75183, 8830, 75114, 9614, 26LS31 (or equivalent)
Encoder signals	Differential quadrature
Input threshold	± 750 mV
Input termination	150 ohm, provided on board
Maximum input voltage	5 V
Maximum input signal frequency	720 Khz (2.88 M feedback unit count rate)
I/O Port Analog Input	
Input channels	1
Resolution	1mv
Input voltage range	± 10.24 V
Accuracy	$\pm 1\%$ of FSR
Sample rate	125 μ sec
Common mode filter	3 dB @ 122 Khz
Differential mode filter	3 dB @ 1826 Hz

Axis and I/O Port Inputs	
Configuration	Axis I/O Ports Inputs: Sink or Source (1) I/O Port Input: Sink or Source (1) Operates with IEC Type 1 inputs (per IEC 1131-2).
Input voltage	Nominal 24 VDC, maximum 30 VDC
Guaranteed on voltage	15 VDC
Guaranteed off voltage	5 VDC
Turn on/off time	1 ms
Fast Input (Input 1, located on J1, pin 5)	50 μ sec turn-on, 400 μ sec turn-off
Axis Port DC Outputs	
Number of outputs	2
Configuration	The set of axis outputs can be configured as sourcing or sinking.
Maximum current	100 mA per output
Voltage range	24 VDC nominal, 5 to 30 VDC range
Scan loss response	Outputs turn off

5 CE and EMC Guidelines

NOTE

The CE mark on PiC products assures compliance with both the EMC and low voltage European directives. Prior to this CE mark, EMC on the product label only assured compliance with the EMC directives.

5.1 Background on EMC (Electromagnetic Compatibility) Compliance

In order to market products in the European Union after January 1, 1996, an electromagnetic compatibility directive (EU Directive 89/336/ECC) must be met. All products must be designed and manufactured in such a way that:

- Electromagnetic disturbances generated by the products do not cause interference to other systems.
- The performance of the product is not affected by electromagnetic disturbances within the environment in which the product is intended to operate.

The directive refers to relevant harmonized European EMC standards against which product conformity can be assessed, although other methods of assessment, notably the preparation of a Technical File, are permissible. The equipment manufacturer or the manufacturer's agent in the Community must make a Declaration of Conformity and can place the CE mark on the product. Failure to conform with the requirements of the directive can result in a total ban on sales throughout the Single Market and legal action could be taken against the signatory of a false declaration of conformity.

5.2 Background on Low Voltage Compliance

In order to market products in the European Union after January 1, 1997, the low voltage directive (EU Directive 73/23/EEC) must be met.

The intention of the directive is to assure user safety under normal operating and fault conditions. The directive includes the use of certain warning labels and user instructions. It establishes limits to prevent electrical shock hazard, overheating and fire.

5.3 RFI Emission and Immunity

The EMC product characteristics are classified by the emission and immunity performance.

Emissions not only include radiated noise from the product enclosure and cabling, but also that which is conducted away from the product along the cables connected to it. This may be subsequently radiated from the cable or conducted directly into another product which shares this cable e.g. the main AC supply.

Immunity is how susceptible a product is (e.g. to the radiated and conducted emissions from the product mounted next to it). To ensure compatibility, the immunity of a product must always exceed the expected emissions in the environment in which it operates as is shown in the diagram below. This is to ensure a margin of safety.

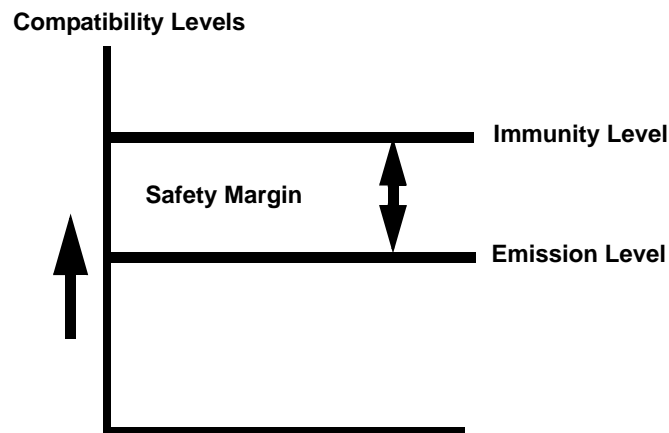
Figure 5-1: Safety Margin

In addition to conducted and radiated immunity, products must also be capable of withstanding:

- Electrostatic discharges (ESD)
- Conducted fast transient voltages

The discharge spark generated from ESD can easily damage electronic components. The conducted fast transient voltages are induced in cables laid in close proximity to other cables in which large inductive loads are switched (such as relays, contactors, and AC motor starters). This is a good example of what can happen to sensitive control and signal cabling connected to drives when poorly installed in enclosures on industrial sites.

5.4 Classes of EMC Operating Environments

Before the correct level of EMC can be designed into equipment, the EMC operating environment must be defined. For example in industrial locations where high power equipment is in use, high levels of background electrical noise would be expected when compared to a household or office environment. Since it is more expensive to reduce the emissions from higher power equipment than to increase the immunity, the emission limits allowed in industrial environments are higher than for household or office environments. Vice versa for immunity because of the higher emission limits in industrial environments, the immunity requirements are more strict than for the household or office environment. Hence in order to achieve EMC between different equipment, it is essential to know what EMC operating environment it is to be installed in, and to compare the installation environment to the environment for which it was designed.

Today using generic EMC standards, two environments are defined:

1. Industrial
2. Residential, commercial, and light industrial

The environments are locations defined on the basis of whether the AC supply is shared with other locations or is buffered from them with a distribution transformer. If your location is buffered via a distribution transformer, then you are in an industrial environment. If you share your AC supply with a neighboring location, then you are in

a residential, commercial, or light industrial environment. For example, an industrial unit which shares its AC supply with a neighboring unit is defined as a residential, commercial, and light industrial location. If it is supplied from its own distribution transformer, then it is an industrial location.

5.5 Conformance with the EMC Directive

Kollmorgen will be complying to the Directive by self-certification to the following generic EMC standards:

- EN50081-2 for industrial emissions using EN55011 (based upon CISPR 11A)
- EN50082-2 for industrial immunity using:
 - IEC 61000-4-2 (ESD- 4KV contact mode, 8 KV air discharge)
 - IEC 61000-4-3 (Radiated susceptibility)
 - IEC 61000-4-4 (Electrical fast transient)
 - IEC 6100-4-8 (Magnetic fields)

A statement of compliance will be made with the letters “EMC” or “CE” on the product, but will be valid only if the product is installed properly.

5.6 Conformance With the Low Voltage Directive

Kollmorgen will comply with the Directive by self certification to the following standard:

- EN 61131-2:1994/A11:1996 Low Voltage Requirements for Programmable Controllers

A statement of compliance will be made with the letters “CE” on the product but will be valid only if the equipment is properly installed.

5.7 Changes to the PiC Products

Kollmorgen PiC products had originally been designed with a high level of noise immunity and tested according to standards such as NEMA showering arc and the original version of IEC 801-2. However, the EU directive for immunity requires testing to standards that have more variables and are more repeatable. The directive also requires control of emissions, something that is not regulated in U. S. industrial environments.

As a result, changes have been made to the hardware modules within the PiC product line. The changes have included the addition of filtering, re-routing of foils and/or the addition of ground planes to printed circuit boards, use of some conductive enclosures, provision for shielded wires (see Note below) for peer-to-peer communication, and internal connection of SPG to field side connectors.

NOTE

A recommended shielded wire is Belden, 24 AWG (7X32), 9729

5.7.1 Changes Affecting the User

Many of the changes Kollmorgen has implemented are transparent to the user. However, there are some changes affecting user installation.

Kollmorgen continues to recommend separation of low level signals (encoder, analog, communications, fast DC inputs) from high voltage or high current lines from any of

the above. More specifically, maintain *at least* one inch of separation around encoder signals and around communication signals.

It is no longer necessary to connect a wire from a module to SPG. This user-installed wire had been a source of emissions and thus the connection should not be made. Analog modules typically had this requirement in the past.

To prevent excessive conducted emissions from a DC power source (typically 24V) used for digital I/O, a 1000 picofarad capacitor should be used. Connect the capacitor from the +24V DC to COMMON at the distribution terminals. The same applies to any other external DC power source used with the PiC product.

The figure on the left below illustrates the connection method *before* EMC compliant products were available. The figure on the right illustrates the recommended connections when using EMC compliant products. On the right, note that the SPG connection has been eliminated and that a capacitor is connected to the 24V DC supply.

Figure 5-2: Connections for EMC Compliance

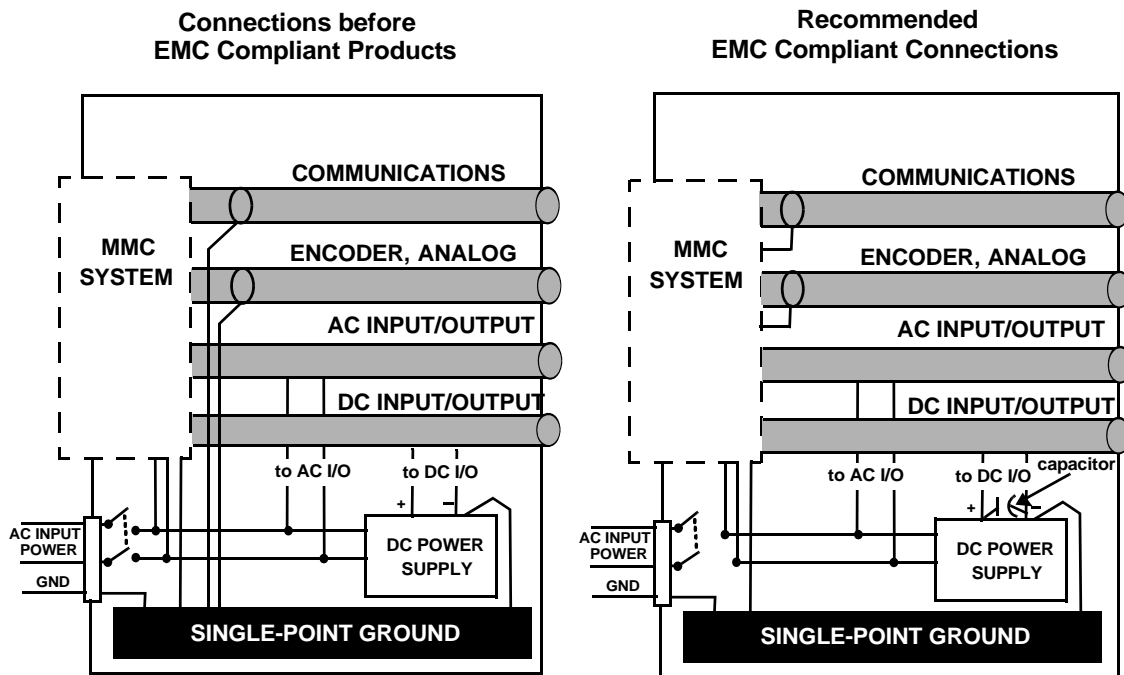

There is now a provision for shield termination to the CPU modules for peer-to-peer communication. Shielded cable must be used to reduce emissions.

Inside a control cabinet, the practice of connecting the shields of shielded cables at the modules should be continued. For an example of a shielded cable entering/leaving the cabinet see [Figure 5-3 on page 67](#).

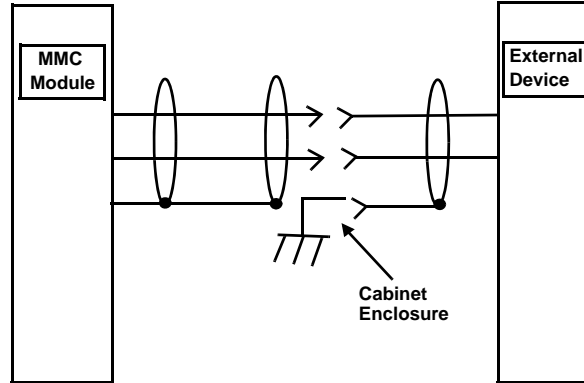
Figure 5-3: Connecting Shielded Cable

The two different methods of terminating shields are used to accommodate two different immunity requirements. Immunity required inside an enclosure is considered lower because cables are typically less than 3 meters in length and/or can be separated from each other and from noise sources.

Immunity required external to an enclosure is considered higher because the user may have less control over the noise environment. Low level signal cables that can be external to an enclosure and AC/DC digital I/O cables have been tested at a 2 KV level for electrical fast transients (EFTs). Low level signals that can be less than 3 meters in length or can be separated from noise sources are tested at a 1 KV level.

Under the stated conditions, there will be no disturbance of digital I/O, encoder, or stepper operation. For analog signals, there may be momentary disturbances but there will be self-recovery when the noise subsides.

In order to meet the EU directive requirement for emissions and immunity, fiber optics must be used for I/O expansion.

Although the control will pass the electrical fast transient test on incoming power lines, users may still want to use a power line conditioner.

As a general precaution, do not operate transmitters, arc welding equipment, or other high noise radiators within one meter of a PiC enclosure that has the door open. Continue to equip inductive devices, if they are in series with a mechanical contact or switch, with arc suppression circuits. These devices include contactors, solenoids and motors. Shield all cables that carry heavy current near the system, using continuous foil wrap or conduit grounded at both ends. Such cables include power leads for high-frequency welders and for pulse-width-modulated motor drives.

NOTE

Shields for signal wires are grounded at only one end, to provide immunity to outside noise sources. However, the shields for "noise sources" are grounded at both ends, to reduce emissions and "contain" the noise.

Worst case tests with analog I/O modules have caused momentary disturbances no greater than .5V in a +10V to -10V range and .5 mA in a 4 to 20 mA range. Worst case tests with an RTD module have caused momentary disturbances no greater that + or -

4°C in a range of -200° to 266°C. Worst case tests with a JK thermocouple module have caused momentary disturbances no greater than + or - 1 mV over a 100 to 1.

NOTE
To assure compliance with the low voltage directive, it is necessary to follow installation instructions in the controller Hardware Manual. Also refer to any instructions specific to individual control modules.

5.8 Using CE/EMC and Non-CE/EMC Modules

IMPORTANT
Failure to follow these guidelines may result in undesired system performance.

NOTE
CE indicates compliance to both the EMC and low voltage directives. EMC indicates compliance to the EMC directive.

There are several issues that must be considered when using CE/EMC compliant and Non-CE/EMC compliant Modules. This document addresses these issues.

Module Identification - To determine whether a module is CE/EMC or Non-CE/EMC, look at the gray Unit Tag located on the side of the plastic module case. CE/EMC modules will have “CE” or “EMC” printed near the “MAX. AMBIENT TEMP.” specification. Non-CE/EMC will not have “CE” or “EMC” printed in this location.

Grounding - Due to differences in shielding requirements, it is extremely important to follow proper shielding guidelines for a given module. Failure to do so may result in intermittent operation in noisy environments.

For modules that have an SPG terminal and/or one or more SHIELD terminal, perform the following:

- For CE/EMC modules, do not connect the SPG terminal or SHIELD terminals to the system’s Single Point Ground
- For Non-CE/EMC modules, connect the SPG terminal, or a SHIELD terminal, to the system’s Single Point Ground

CE/EMC CSM and RSM Modules - Using a CE/EMC CSM, RSM, or CSM/CPU (PiC90) with certain Non-CE/EMC analog modules may cause intermittent operation. Follow these guidelines for determining the type of CSM, RSM, or CSM/CPU that should be used in a particular rack:

- If your rack contains one or more Non-CE/EMC modules that perform D/A conversion or provide an Encoder interface, you must use a non-CE/EMC CSM, RSM, or CSM/CPU (PiC90).
- If your rack contains one or more Non-CE/EMC modules that perform D/A conversion or provide an Encoder interface, you must use a non-CE/EMC CSM, RSM, or CSM/CPU (PiC90).

- If your rack does not contain one or more Non-CE/EMC modules that perform D/A conversion or provide an Encoder interface, you may use either a CE/EMC or Non-CE/EMC CSM, RSM, or CSM/CPU (PiC90).

NOTE

For a system to be CE/EMC compliant, all modules and backplanes must be CE/EMC compliant

5.9 Declarations of Conformity

The undersigned, representing the supplier

G & L Motion Control Inc.
672 South Military Road
Fond du Lac, Wisconsin 54936-1960

herewith declares that all **PiC900™/PiC90™/PiC9™/MMC and Block I/O modules**, labeled with the CE mark, are in conformity with the provisions of the following EC Directives when installed in accordance with the installation instructions contained in the product documentation:

Low Voltage Directive 73/23/EEC as amended by 93/68/EEC
EMC Directive 89/336/EEC as amended by 92/31/EEC and 93/68/EEC

Conformity of the specified product is based upon application of the following standards and/or technical specifications referenced below:

<i>EN 50081-2:1993</i>	<i>EMC Generic Industrial Emissions</i>
<i>EN 50082-2:1995</i>	<i>EMC Generic Industrial Immunity</i>
<i>EN 61131-2:1994/A11:1996</i>	<i>Low voltage requirements for programmable controllers</i>
<i>EN61326:1997</i>	<i>Electrical Equipment for measurement, control and Laboratory use – EMC requirements</i>

Year of Marking: 2002

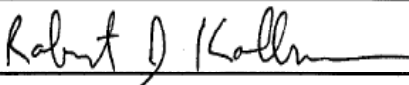
<i>Signature</i>	
<i>Full Name</i>	Robert J. Kollmeyer
<i>Position</i>	Director of Engineering
<i>Place</i>	G & L Motion Control Inc.
<i>Date</i>	05-APR-05

EC DECLARATION OF CONFORMITY

The undersigned, representing the supplier

G & L Motion Control Inc.
672 South Military Road
Fond du Lac, Wisconsin 54936-1960

herewith declares that all **three-phase current synchronous motors, type MSM** are in conformity with the provisions of the following EC Directive when installed in accordance with the installation instructions contained in the product documentation:

Low Voltage Directive 73/23 EWG

Conformity of the specified product with the guidelines of this directive will be proved by the total compliance with the following harmonic European standards:

EN 60034-1: November 1995 Rotating Electrical Machines
EN 60034-5: April 1998
EN 60034-9: May 1996

Year of Marking: 1999

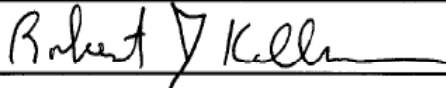
<i>Signature</i>	
<i>Full Name</i>	Robert J. Kollmeyer
<i>Position</i>	Director of Engineering
<i>Place</i>	G & L Motion Control Inc.
<i>Date</i>	05 - APR - 05

EC DECLARATION OF CONFORMITY

The undersigned, representing the supplier

G & L Motion Control Inc.
672 South Military Road
Fond du Lac, Wisconsin 54936-1960

herewith declares that all **three-phase current synchronous motors, type LSM** are in conformity with the provisions of the following EC Directive when installed in accordance with the installation instructions contained in the product documentation:

Low Voltage Directive 73/23 EWG

Conformity of the specified product with the guidelines of this directive will be proved by the total compliance with the following harmonic European standards:

EN 60034-1: September 2000 Rotating Electrical Machines
+A11 May 2002
EN 60034-5: December 2001
EN 60034-9: June 1998

Year of Marking: 2002

<i>Signature</i>	<i>Robert J. Kollmeyer</i>
<i>Full Name</i>	Robert J. Kollmeyer
<i>Position</i>	Director of Engineering
<i>Place</i>	G & L Motion Control Inc.
<i>Date</i>	<i>05-APR-05</i>

EC DECLARATION OF CONFORMITY

The undersigned, representing the supplier

**G & L Motion Control Inc.
672 South Military Road
Fond du Lac, Wisconsin 54936-1960**

herewith declares that all **MMC Smart Drives (MMC-SD-XXX-230-XXX, MMC-SD-XXX-460-XXX) and accessories** are in conformity with the provisions of the following EC Directive(s) when installed in accordance with the installation instructions contained in the product documentation:

<i>73/23/EEC</i>	<i>Low Voltage Directive as amended by 93/68/EEC</i>
<i>89/336/EEC</i>	<i>EMC Directive as amended by 92/31/EEC and 93/68/EEC</i>

and that the standards and/or technical specifications referenced below have been applied:

<i>EN 50178:1998</i>	<i>Electronic equipment for use in power installations</i>
<i>EN 61800-3:1996</i>	<i>Adjustable speed electrical power drive systems – EMC</i>
<i>/A11:2000</i>	<i>product standard including specific test methods</i>

Year of Marking: 2003

<i>Signature</i>	<i>Robert J. Kollmeyer</i>
<i>Full Name</i>	Robert J. Kollmeyer
<i>Position</i>	Director of Engineering
<i>Place</i>	G & L Motion Control Inc.
<i>Date</i>	<i>05-APR-05</i>

Appendix A - Operation Details

6.1 Introduction

This appendix describes in detail the operation of many of the sub-systems found within the MMC Control and Option Modules.

6.2 DC Inputs

Each input is guaranteed “on” at 14 to 30 VDC and guaranteed “off” at 0 to 5 VDC (polarity doesn't matter). Its on/off state is converted to a corresponding logic 1 or 0. This logic state is transmitted through the system bus to the application program, which uses these logic states to control program flow. The logic side of the input is optically isolated from the field side.

The shaded blocks in [Figure 6-1](#) below show the limits specified by the IEC. The lines show the maximum and minimum V/I of the inputs in this module. The voltage/current curve in this graph shows that the input module is well within the IEC Type 1 limits.

Figure 6-1: Input Characteristics Compared to IEC Standards

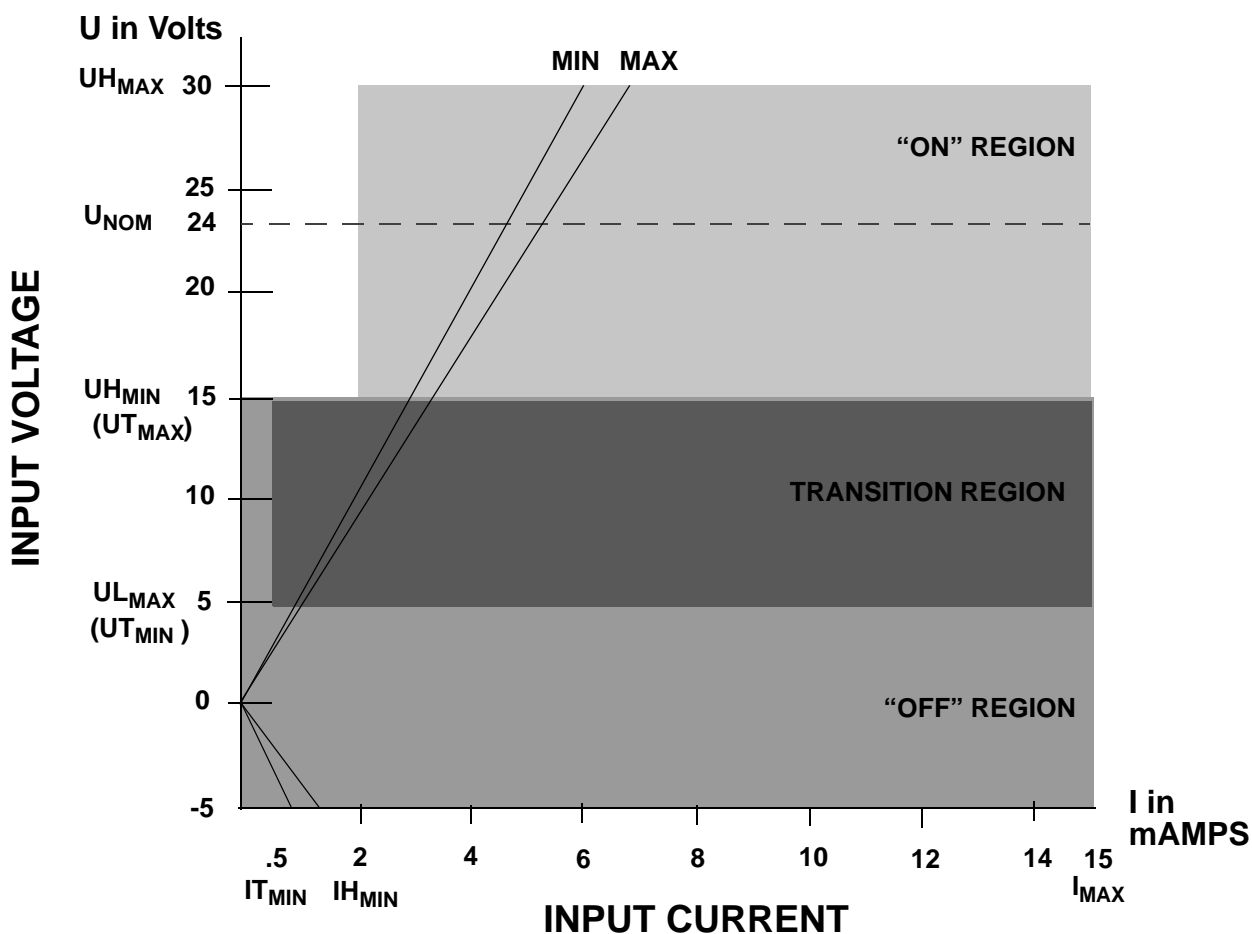

IMPORTANT

Switching devices can sometimes have a leakage current that exceeds the $I_{T_{min}}$ (current allowed when off) of an input module. In order to use such a device, an impedance (typically, a resistor) needs to be used in parallel with the input.

For example, some of the newer proximity switches use two wires instead of three. The third wire was used for a power or ground line. Without the third wire, the switch is easier to install. However, it requires more leakage current in the off state to power its internal circuitry.

As a conservative estimate, use the following formula to calculate an external resistance value. It keeps the input voltage at or below 2.4V when the switching device is in the "off" state.

$$\frac{2.4V}{\text{Switch Leakage} - 0.75mA} \geq R$$

If the switch leakage specification is ≤ 1.7 mA, then:

$$\frac{2.4V}{1.7 - 0.75mA} \geq 2.5K\Omega$$

Use a resistor less than or equal to 2.5 K Ω . Be sure that the wattage is adequate for the resistor when the switching device is in the "on" state remembering that:

$$P = \frac{V_{ON}^2}{R}$$

6.3 DC Outputs

A DC Output consists of a solid state switch. It turns on or off according to the logic state sent to it by the application program. If the application program sends it a logic 1, the switch closes and the device is powered. If the application program sends a logic 0, the switch opens and power to the device is cut off. The application program updates the logic state for each switch every time it scans the program.

The logic side of the switch is optically isolated from the field side. If you need to know whether voltage is actually present at the field side, use a voltmeter.

6.3.1 Inductive Loads

Resistive and inductive loads can be connected to DC outputs and controlled by the system with no precautions other than making sure they have a connection to the common of the DC power supply.

Inductive loads have an electrical "kickback" when current is stopped. This can damage or destroy the output switching device. Each output has a diode through which reverse current can be safely routed.

The internal diode works with an inductive load. When an output is energized, represented by a closed switch, current passes through the load into the common line. When the output is de-energized, represented by an open switch, current stops and the inductive field collapses. The state of the outputs is controlled by the CPU. This creates a reverse voltage across the load called "kickback" which tries to continue the

current. The voltage is in series with the DC power supply. The combined voltage appears across the output switching device in the module.

If this were the only path available, voltage across the device would peak at several hundred volts. The internal diode provides another path for current. This limits the peak reverse voltage across the load to less than 1 V. Every DC output has this protection so an inductive load can be connected safely.

Figure 6-2: Diagram of Internal Protection for Inductive Loads

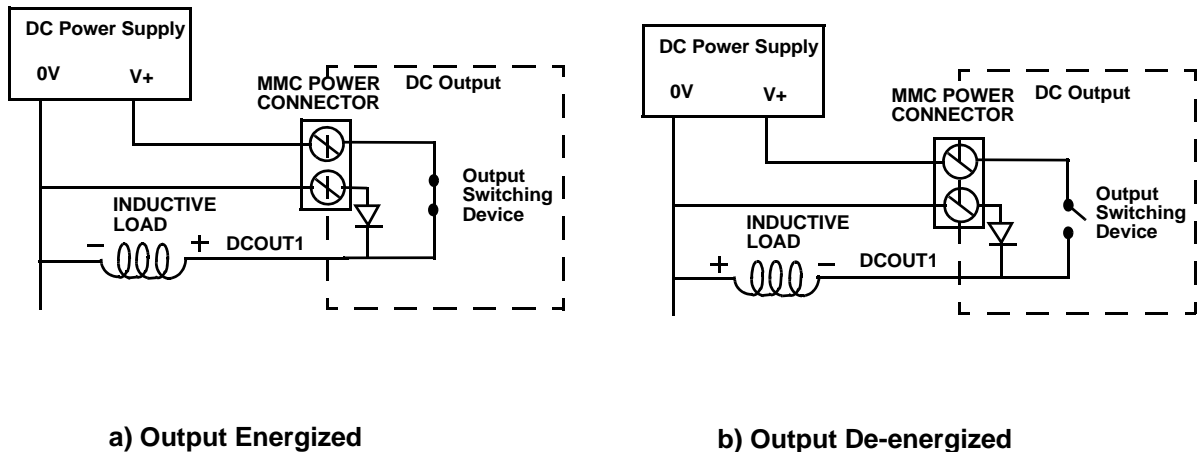

6.4 Encoder Inputs

The encoder inputs use differential type inputs to interface with incremental encoders. These inputs accept RS422 level quadrature signals. Recommended encoder drivers include 7272, 75183, 8830, 75114, 9614, 26LS31 (or equivalent).

A *quadrature encoder* sends square wave type signals. When the shaft rotates at a constant velocity, the A and B outputs are square waves and are at the same frequency. However they are out of phase with each other by 90°. When the encoder shaft rotates in one direction, each A pulse leads the corresponding B pulse by 90°. When it rotates the other direction each A pulse lags its B pulse by 90°.

The signals illustrated in [Figure 6-3](#) below indicate that the encoder shaft rotates in one direction at first. Its speed of rotation decreases to 0 and then it starts rotating the other direction. The signals are shown as differential. \bar{A} is the inverse of the signal A and \bar{B} is the inverse of signal B.

Figure 6-3: Signals Transmitted by a Quadrature Encoder with Differential Outputs

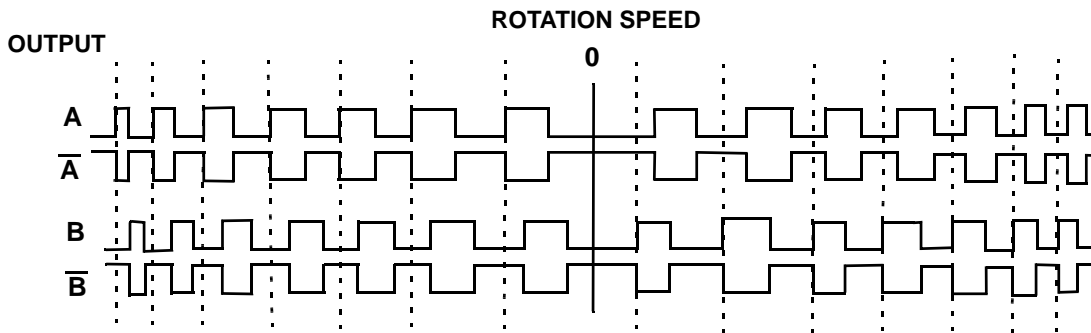

The maximum input frequency is 250,000 lines per second, which results in 1,000,000 Feedback Units (FUs) per second.

Figure 6-4: Counting Quadrature Pulses

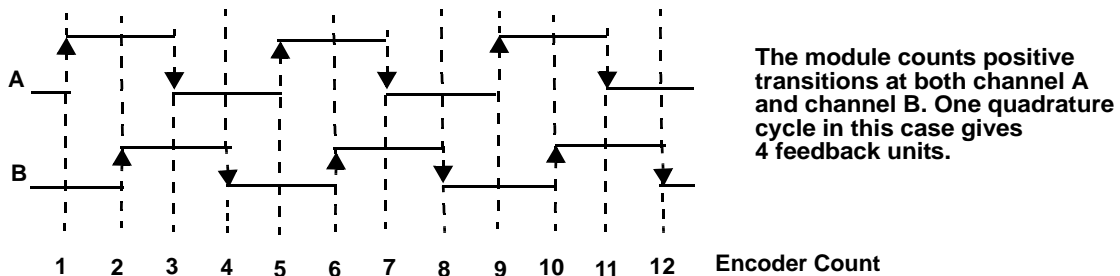

There is a 24-bit up/down counter for each channel. It is incremented or decremented on each A, B edge. There is also a 24-bit latch associated with each encoder channel.

The module can be programmed so that the counter value is “latched” or stored under one of these conditions:

- an index pulse from the encoder
- a positive or negative transition of the fast input
- the next index pulse after the required transition of the fast input

Each of the five 24-bit latches has a *fast 24 VDC input* associated with it. Each input is optically isolated. This input is intended to receive a signal from a device other than an encoder. It is typically used for referencing or synchronization purposes.

Fast input characteristics include:

- the detection of a signal occurs faster than it does for the DC inputs in other modules, due to less filtering. Because of this there is also less noise immunity.
- the response to a fast input signal is independent of ladder scan time. The module can be programmed to latch a position count as soon as this input is detected.

Index

A

- address switches
 - DL-DIU 42
 - slice I/O coupler 20
- analog input port details
 - DL-DIU 57
- axis I/O port (DL-DIU) 45
 - analog output 52
 - DC input 51
 - DC outputs 49
 - encoder input 53

C

- CE guidelines 63
- Compliance
 - to low voltage directive 63
- conformance
 - EMC directive 65
 - low voltage directive 65
- conformity
 - declaration of 70
- connections
 - for EMC compliance 66
- contents of the manual 5

D

- DC input connectors
 - slice I/O coupler 24
- DC inputs
 - operation
 - general 75
- DC output connectors
 - slice I/O coupler 26
- DC outputs
 - general operation 76
 - inductive loads 76
- declaration of conformity 70
- diagnostic indicator
 - DL-DIU 41
- digital link LEDs
 - DL-DIU 41
- digital link ports
 - DL-DIU 43
 - slice I/O coupler 21
- DL-DIU
 - address switches 42
 - axis I/O port 45
 - analog output 52
 - DC input 51
 - encoder input 53

- axis I/O port DC outputs 49
- diagnostic indicator 41
- digital link LEDs 41
- digital link ports 43
- front panel details 41
- I/O and power ports 54
 - analog input port details 57
 - input port details 56
 - wiring example 57
- introduction 39
- LEDs 41
- power indicator 41
- specifications 59

E

- electrical service & maintenance safety 10
- electro-static discharge 64
- EMC
 - modules 68
 - operating environments 64
 - PiC products 65
- EMC directive
 - conformance 65
- EMC guidelines 63
- encoder inputs
 - general operation 77
- ESD 64

F

- fast transient voltage 64
- features
 - slice I/O 13
- front panel details
 - DL-DIU 41

G

- grounding
 - protective earth 8
- guidelines
 - CE 63
 - EMC 63

I

- I/O and power ports
 - DL-DIU 54
- inductive loads
 - DC outputs 76
- input port details
 - DL-DIU 56
- inspection
 - safety 9
- installation
 - slice I/O 16

L

LED indicators
slice I/O coupler [19](#)

LEDs
DL-DIU [41](#)

low voltage directive
conformance [65](#)

M

manual cleaning procedure [11](#)

O

operation
DC inputs [75](#)
DC outputs [76](#)
encoder inputs [77](#)
safety [10](#)

P

power connector
slice I/O [23](#)
power indicator
DL-DIU [41](#)
procedure
manual cleaning [11](#)
protective earth
grounding [8](#)

R

RFI
emission [63](#)
immunity [63](#)

S

safety
after shutdown [9](#)
cleaning [11](#)
electrical service & maintenance [10](#)
inspection [9](#)
operating safely [10](#)
operation [10](#)
signs [8](#)
system [7](#)
warning labels [8](#)
Sales and Service [82](#)
Service [82](#)

signs
safety [8](#)
Slice I/O [13](#)
slice I/O
coupler details [19](#)
features [13](#)
installation [16](#)
module removal [17](#)
power connector [23](#)
terminal block operation [18](#)
wiring example [27](#)
slice I/O coupler
address switches [20](#)
DC input connectors [24](#)
DC output connectors [26](#)
digital link ports [21](#)
LED indicators [19](#)
specifications [37](#)
slice I/O modules
description [30](#)
limitations and precautions [30](#)
types available [30](#)
software
required [5](#)
specifications
DL-DIU [59](#)
slice I/O coupler [37](#)

T

technical support contacts [6](#)
terminal block operation
slice I/O [18](#)

V

voltage
fast transient [64](#)

W

warning label
danger, warning, caution [9](#)
hazard [8](#)
Web Address [82](#)
wiring
for EMC compliance [66](#)
wiring example
DL-DIU [57](#)
slice I/O [27](#)

Sales and Service

We are committed to quality customer service. In order to serve in the most effective way, please contact your local sales representative for assistance.

If you are unaware of your local sales representative, please contact us.

North America

Kollmorgen Customer Support North America

E-mail: glmotion.support@kollmorgen.com
Phone: In the United States, telephone (800) 558-4808
Outside the United States, telephone (920) 921-7100
Fax: (920) 906-7669
Web site: www.kollmorgen.com

Europe

Kollmorgen Customer Support Europe

E-mail: glmotion.support@kollmorgen.com
Phone: +44 (0)1525 243-243
Fax: +44 (0)1525 243-244
Web site: www.kollmorgen.com

KOLLMORGEN[®]

Because Motion Matters™