

MKD[®] Multi Axes System

Installation Manual

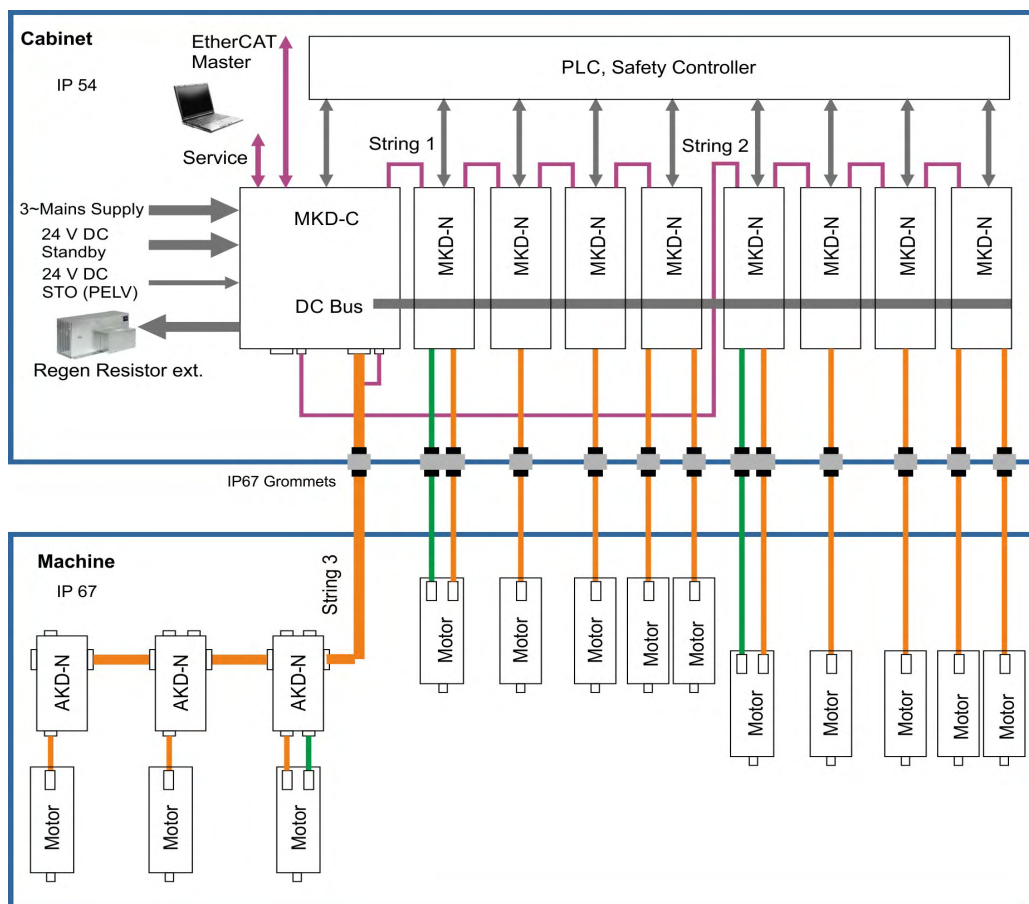

Edition: A, January 2019

Valid for MKD-C, Hardware Revision A

Valid for MKD-N, Hardware Revision -

Part Number 904-200003-00

Original Document



For safe and proper use, follow these instructions. Keep them for future reference.



KOLLMORGEN

Because Motion Matters™

Record of Document Revisions

Revision	Remarks
...	Table with lifecycle information of this document see (→ # 137)
A, 01/2019	First edition

Hardware Revision (HR)

MKD-N	MKD-C	Firmware	WorkBench	Remarks
A	A	from 1.18	from 1.18	MKD-C and MKD-N start revisions

Trademarks

- EnDat is a registered trademark of Dr. Johannes Heidenhain GmbH
- EtherCAT is a registered trademark and patented technology, licensed by Beckhoff Automation GmbH
- SpeedTec is a registered trademark of TE Connectivity Industrial GmbH
- Windows is a registered trademark of Microsoft Corporation

Current patents

Patents referring to fieldbus functions are listed in the matching fieldbus manual.

Technical changes which improve the performance of the device may be made without prior notice!

This document is the intellectual property of Kollmorgen. All rights reserved. No part of this work may be reproduced in any form (by photocopying, microfilm or any other method) or stored, processed, copied or distributed by electronic means without the written permission of Kollmorgen.

1 Table of Contents

1 Table of Contents	3
2 General	9
2.1 About this Manual	10
2.2 Using the PDF Format	10
2.3 Symbols Used	11
2.4 Abbreviations Used	12
2.5 Standards Used	13
3 Product Safety	14
3.1 You should pay attention to this	15
3.2 Shock-hazard Protection	17
3.2.1 Leakage current	17
3.2.2 Residual current protective device (RCD)	17
3.2.3 Isolating transformers	17
3.3 Stop / Emergency Stop / Emergency Off	18
3.3.1 Stop	18
3.3.2 Emergency Stop	19
3.3.3 Emergency Off	19
3.4 Use as Directed	20
3.5 Prohibited Use	21
3.6 Warning note labels	21
3.6.1 Notes placed on the product	21
4 Product life cycle handling	22
4.1 Packaging	23
4.2 Transport	23
4.3 Storage	23
4.4 Installation, setup and normal operation	24
4.5 Decommissioning	24
4.6 Maintenance and cleaning	24
4.7 Disassembly	24
4.8 System Repair	25
4.9 Disposal	25
5 Approvals	26
5.1 Conformance with UL/cUL	27
5.2 Conformance with EC Low Voltage and EMC Directives	27
5.3 Conformance with EC Machinery Directive, Functional Safety	27
5.4 Conformance with RoHS	27
5.5 Conformance with REACH	27
6 Package	28
6.1 Package Supplied	29
6.2 Nameplate	30
6.2.1 MKD-C modules	30
6.2.2 MKD-N modules	30
6.3 Part Number Scheme	31
6.3.1 MKD-C modules	31
6.3.2 MKD-N modules	31
7 Technical description and data	32
7.1 The MKD Multi Axes System	33
7.2 Mechanical Data	34
7.3 Performance Data	34
7.4 Electrical Data	35

7.4.1 MKD-C	35
7.4.2 MKD-N, single axis	36
7.4.3 MKD-N, dual axis	36
7.5 Fusing	37
7.5.1 External power supply and 24 V fusing	37
7.5.2 External regen resistor fusing	37
7.5.3 DC-Bus link fusing	37
7.6 Ambient Conditions in normal operation	38
7.7 Ground System	38
7.8 Connectors	39
7.9 Recommended Tightening Torques	40
7.9.1 MKD-C	40
7.9.2 MKD-N	40
7.10 Cable Requirements	41
7.10.1 MKD-C	41
7.10.2 MKD-N	42
7.11 Cable Length Definition	43
7.12 Dynamic Braking	44
7.13 Regen circuit	44
7.13.1 Functional description	44
7.13.2 Technical data	44
7.14 LED signals	45
7.14.1 MKD-C	45
7.14.2 MKD-N	46
7.14.3 RJ45 LED signals	46
7.15 Push-button (B1)	47
7.16 Rotary Switch (S1), Setting IP address	48
8 Mechanical Installation	49
8.1 Important Notes	50
8.2 Guide to Mechanical Installation	50
8.3 Dimension Drawing	51
8.4 Mounting Example	52
9 Electrical Installation	53
9.1 Important Notes	54
9.2 Guide to Electrical Installation	55
9.2.1 MKD-C	55
9.2.2 MKD-N (string 1)	56
9.2.3 AKD-N (strings 2 or 3)	56
9.3 Wiring	57
9.4 EMI Noise Reduction	58
9.4.1 Recommendations for EMI noise reduction	58
9.4.2 Shielding connection to the system modules	59
9.4.2.1 Ethernet connectors X10, X11, X18, X22, X27, X28	59
9.4.2.2 Power connectors with shield plate X12, X14, X20A, X20B	59
9.4.2.3 Local fieldbus connectors X21A, X21B	59
9.4.2.4 Example for system earthing	60
9.5 System topology of an MKD drive system	61
9.5.1 System limits	61
9.5.2 Topology example with two external strings	62
9.5.3 Topology example with one external string migrated to cabinet	63
9.6 Connection Overview	64
9.6.1 Connector Position MKD-C	64
9.6.2 Connector Position MKD-N (6A, 12A)	65
9.6.3 Connector Position MKD-N (24A)	66

9.6.4 Connector Position MKD-N (48A)	67
9.6.5 Connection diagrams	68
9.6.5.1 MKD-C	68
9.6.5.2 MKD-N (6A, 12A)	69
9.6.5.3 MKD-N (24A, 48A)	70
9.6.6 Connector pin assignments	71
9.6.6.1 X9A, X9B: MKD-N, Brake interruption	71
9.6.6.2 X10, X11: MKD-C, EtherCAT Fieldbus In/Out	71
9.6.6.3 X12: MKD-C, Mains Supply	71
9.6.6.4 X13: MKD-C, 24V DC Logic Supply	72
9.6.6.5 X14: MKD-C, External regen resistor	72
9.6.6.6 X15A, X15B: MKD-C, I/O	72
9.6.6.7 X16A, X16B: MKD-C, Global STO String 2 and 3	73
9.6.6.8 X18: MKD-C, Service	73
9.6.6.9 X20A, X20B: MKD-C, String 2/3 DC Power	74
9.6.6.10 X21A, X21B: MKD-C, String 2/3 Communication	74
9.6.6.11 X22: MKD-C, String 1 Communication	74
9.6.6.12 X23: MKD-C, MKD-N, String 1 DC Power	74
9.6.6.13 X24A, X24B: MKD-N, I/O	75
9.6.6.14 X25: MKD-C, DC Bus sharing	75
9.6.6.15 X26A, X26B: MKD-N, Local STO	76
9.6.6.16 X27, X28: MKD-N, String Communication	76
9.6.6.17 X29A, X29B: MKD-N 6A or 12A, Motor Power, Brake	77
9.6.6.18 X29A: MKD-N 24A or 48A, Motor Power	77
9.6.6.19 X30A: MKD-N 24A or 48A, Motor Brake	77
9.6.6.20 X31A, X31B: MKD-N, commutation Feedback 1	78
9.6.6.21 X32A, X32B: MKD-N, commutation Feedback 2	78
9.6.6.22 X33A, X33B: MKD-N, secondary Feedback	79
9.7 Electrical Supply Connection	80
9.7.1 Connection to various mains supply networks	80
9.7.2 Mains supply connection (X12)	81
9.7.2.1 Three phase connection	81
9.7.3 Logic supply voltage 24 VDC (X13)	82
9.8 DC Bus link (X20, X23, X25)	83
9.8.1 DC Bus bar MKD-C to MKD-N, MKD-N to MKD-N	83
9.8.2 DC Bus Strings MKD-C to AKD-N	83
9.8.3 DC Bus sharing MKD-C to MKD-C	83
9.8.4 Drive String Connection	84
9.8.4.1 String 1 (central)	85
9.8.4.2 Strings 1 and 2 (central)	86
9.8.4.3 Strings 2 and 3 (decentral)	87
9.8.5 External Regen resistor (X14)	88
9.9 Motor Connection	89
9.9.1 Motor single cable connection (X29, X30, X31)	90
9.9.1.1 Motor Power and Motor Brake X29, Motor Feedback X31	91
9.9.1.2 Motor Power X29, Motor Brake X30, Motor Feedback X31	91
9.9.2 Motor dual cable connection (X29, X30, X32)	92
9.9.2.1 Motor Power and Motor Brake X29	93
9.9.2.2 Motor Power X29, Motor Brake X30	93
9.9.2.3 Motor Feedback X32	94
9.10 Secondary Feedback Connection (X33)	95
9.11 I/O Connection	96
9.11.1 Technical Data Inputs/Outputs MKD-C	96
9.11.2 Technical Data Inputs/Outputs MKD-N	96

9.11.3 Pinout MKD-C I/O connectors X15 and X16	97
9.11.4 Pinout MKD-N I/O connectors X24 and X26	98
9.11.5 Wiring of Digital Inputs (X15, X16, X24, X26)	99
9.11.5.1 Digital Inputs MKD-C (X15B)	99
9.11.5.2 Digital Inputs MKD-N (X24)	100
9.11.5.3 STO Enable inputs (X16, X26)	100
9.11.6 Wiring of Digital Outputs (X15, X24)	101
9.11.6.1 Transistor Outputs (X15B, X24)	101
9.11.6.2 Relay Output (X15A)	101
9.11.6.3 STO Status Outputs (X15A, X24)	102
9.12 Motion Bus Interface (X10/X11)	103
9.12.1 Pinout	103
9.12.2 EtherCAT	103
9.13 Service Interface (X18)	104
9.13.1 Pinout	104
9.13.2 Service Bus Protocols	104
10 Functional Safety	105
10.1 STO (Safe Torque Off)	105
10.1.1 STO Safety instructions	105
10.1.2 Use as directed	106
10.1.3 Prohibited use	106
10.1.4 Enclosure, wiring	106
10.1.5 Topology overview	107
10.1.6 OSSD test pulses	107
10.1.7 STO 24 VDC voltage supply	108
10.1.8 Safety characteristic data	108
10.1.9 Response Time	108
10.1.10 Signal diagram (sequence)	108
10.1.11 Global Safe Torque Off (Strings 2 or 3)	109
10.1.11.1 General information	109
10.1.11.2 Technical data and connection	109
10.1.11.3 Global STO application example	110
10.1.11.4 Functional description	111
10.1.11.5 Functional test	112
10.1.12 Local STO on MKD-N	113
10.1.12.1 General information	113
10.1.12.2 Enclosure, wiring	113
10.1.12.3 Technical data and connection	113
10.1.12.4 Local STO application example	114
10.1.12.5 Functional description	115
10.1.12.6 Functional test	115
10.1.13 Local STO on AKD-N	116
10.1.13.1 General information	116
10.2 Brake interruption contact	116
10.2.1 General information	116
11 Setup	117
11.1 Important Notes	118
11.2 Guide to setup	119
11.2.1 System addresses	119
11.2.2 System Setup	120
11.3 Setup software WorkBench	121
11.3.1 Use as directed	121
11.3.2 Software description	122
11.3.3 Hardware requirements	122

11.3.4 Operating systems	122
11.3.5 Installation under Windows	123
11.4 Initial System Test	124
11.4.1 Set system addresses	124
11.4.2 Confirm connections	124
11.4.3 Install and start WorkBench	124
11.4.4 Parameterize and enable the axes in WorkBench	124
12 Appendix	125
12.1 Fault and Warning Messages	126
12.2 Troubleshooting the MKD System	128
12.3 Accessories	129
12.3.1 Mains choke	129
12.3.2 Regen resistors	130
12.3.2.1 Important notes	130
12.3.2.2 Dimensions and Data	131
12.3.3 Cables	132
12.3.3.1 Overview	132
12.3.3.1.1 Hybrid String cables	132
12.3.3.1.2 Hybrid Motor Cables	132
12.3.3.1.3 Motor Power Cables	132
12.3.3.1.4 Motor Feedback Cables	133
12.3.3.1.5 EtherCAT cables	133
13 Index	135
14 Record of Document Revisions	137

-- / --

2 General

2.1 About this Manual	10
2.2 Using the PDF Format	10
2.3 Symbols Used	11
2.4 Abbreviations Used	12
2.5 Standards Used	13

2.1 About this Manual

This manual, the *MKD Multi Axes Installation Manual* describes the MKD drive system modules MKD-C power supply and MKD-N servo drive. It includes all information needed to safely install the MKD system modules.

A digital version of this manual (pdf format) is available on the DVD included with your drive.

Additional documents:

- *WorkBench Online Help*: describes how to use the system in common applications. It also provides tips for maximizing your system performance. The *Online Help* includes the *Parameter and Command Reference Guide* which provides documentation for the parameters and commands used to program the system.
- *EtherCAT Communication*: describes how to use the system in EtherCAT applications.
- *AKD-N Installation Manual*: includes all information needed to safely install the AKD-N drive modules.

All documents can be downloaded from the Kollmorgen website www.kollmorgen.com.











2.2 Using the PDF Format

This document includes several features for ease of navigation











Cross References	Table of contents and index include active cross references.
Table of contents and index	Lines are active cross references. Click on the line and the appropriate page is accessed.
Page/chapter numbers in the text	Page/chapter numbers with cross references are active links.

2.3 Symbols Used

Warning Symbols

Symbol	Indication
	Indicates a hazardous situation which, if not avoided, will result in death or serious injury.
	Indicates a hazardous situation which, if not avoided, could result in death or serious injury.
	Indicates a hazardous situation which, if not avoided, could result in minor or moderate injury.
	Indicates situations which, if not avoided, could result in property damage.
	This symbol indicates important notes.
	Warning of a danger (general). The type of danger is specified by the text next to the symbol.
	Warning of danger from electricity and its effects.
	Warning of danger from hot surface.
	Warning of danger from suspended loads.
	Warning of danger from automatic start.

Drawing symbols

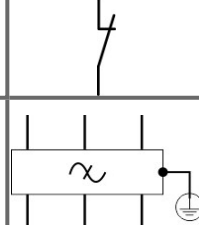
Symbol	Description	Symbol	Description
	Signal ground		Diode
	Chassis ground		Relay
	Protective earth		Relay switch off delayed
	Resistor		Normally open contact
	Fuse		Normally closed contact
	State-of-the-art firewall		EMC filter

2.4 Abbreviations Used

Abbreviation	Meaning
(→ # 53)	"see page 53" in this document
CE	Communauté Européenne
COM	Serial interface for a personal computer
DCOM	Communication line for digital inputs
Disk	Magnetic storage (diskette, hard disk)
EEPROM	Electrically erasable programmable memory
EMC	Electromagnetic compatibility
KAS	Kollmorgen Automation Suite
KAS IDE	Setup software (Kollmorgen Automation Suite Integrated Development Environment)
KDN	Kollmorgen Developer Network
LED	Light-emitting diode
LSB	Low significant byte (or bit)
MSB	Main significant byte (or bit)
NI	Zero pulse
OSSD	Output signals Switching Device
PC	Personal computer
PE	Protective earth
PELV	Protective extra low voltage
PLC	Programmable logic control
PWM	Pulse-width modulation
RAM	Random access memory (volatile memory)
RBrake/RB	Regen resistor (also called a brake resistor)
RBext	External regen resistor
RBint	Internal regen resistor
RCD	Residual current device
RES	Resolver
ROD	Incremental encoder (A quad B)
Rth	Specific thermal resistance
SBC	Safe Brake Control
SELV	Safety Extra Low Voltage
STO	Safe torque off
VAC	Volts, alternating current
VDC	Volts, direct current

2.5 Standards Used

Standard	Content
ISO 4762	Hexagon socket head cap screws
ISO 11898	Road vehicles — Controller area network (CAN)
ISO 12100	Safety of machinery: Basic concepts, general principles for design
ISO 13849	Safety of machinery: Safety-related parts of control systems
IEC 60085	Electrical insulation - Thermal evaluation and designation Maintenance
IEC 60204	Safety of Machinery: Electrical equipment of machinery
IEC 60364	Low-voltage electrical installations
IEC 60439	Low-Voltage Switchgear and Controlgear Assemblies
IEC 60529	International protection rating (IP code)
IEC 60664	Insulation coordination for equipment within low-voltage systems
IEC 60721	Classification of environmental conditions
IEC 61000	Electromagnetic compatibility (EMC)
IEC 61131	Programmable controllers
IEC 61491	Electrical equipment of industrial machines – Serial data link for real-time communications between controls and drives.
IEC 61508	Functional safety of electrical/electronic/programmable electronic safety-related systems
IEC 61800	Adjustable speed electrical power drive systems
IEC 62061	Functional safety of electrical/electronic/programmable electronic safety-related systems
IEC 82079	Preparation of instructions for use - Structuring, content and presentation
UL 61800-5-1	UL Standard for Adjustable Speed Electrical Power Drive Systems - Part 5-1: Safety Requirements - Electrical, Thermal and Energy

IEC - International Electrotechnical Commission

ISO - International Organization for Standardization

UL - Underwriters Laboratories

3 Product Safety

3.1 You should pay attention to this	15
3.2 Shock-hazard Protection	17
3.3 Stop / Emergency Stop / Emergency Off	18
3.4 Use as Directed	20
3.5 Prohibited Use	21
3.6 Warning note labels	21

3.1 You should pay attention to this

Specialist staff required!

Only properly qualified personnel are permitted to perform such tasks as transport, installation and setup. Qualified specialist staff are persons with expertise in transport, installation, assembly, commissioning and operation of electrotechnical equipment.

- Transport, storage, unpacking: only by personnel with knowledge of handling electrostatically sensitive components.
- Mechanical installation: only by personnel with mechanical expertise.
- Electrical installation: only by personnel with expertise in electrical engineering.
- Basic tests / setup: only by personnel with expertise in electrical engineering and drive technology.

The qualified personnel must know and observe ISO 12100 / IEC 60364 / IEC 60664 and national accident prevention regulations.

Read the documentation!

Read the available documentation before installation and commissioning. Improper handling of the devices can cause harm to people or damage to property. The operator of systems using the drive system must ensure that all personnel who work with the drive read and understand the manual before using the drive.

Check Hardware Revision!

Check the Hardware Revision Number of the product (see product label). Hardware Revision Number of MKD-C and MKD-N can differ from each other. This number is the link between your product and the manual. The product Hardware Revision Number must match the Hardware Revision Number on the cover page of the manual.

Pay attention to the technical data!

Adhere to the technical data and the specifications on connection conditions. If permissible voltage values or current values are exceeded, the devices can be damaged. Unsuitable motor or wrong wiring will damage the system components. Check the combination of drive and motor. Compare the rated voltage and current of the units.

Perform a risk assessment!

The manufacturer of the machine must generate a risk assessment for the machine, and take appropriate measures to ensure that unforeseen movements cannot cause injury or damage to any person or property. Additional requirements on specialist staff may also result from the risk assessment.

The manufacturer should define periodic checks of the electrical components and application.

Automatic Restart!

The drive might restart automatically after power on, voltage dip or interruption of the supply voltage, depending on the parameter setting.

Risk of death or serious injury for humans working in the machine.

If the parameter DRV.ENDEFAULT for one MKD-N is set to 1, then place a warning sign to the machine (Warning: Automatic Restart at Power On) and ensure, that power on is not possible, while humans are in a dangerous zone of the machine. In case of using an under-voltage protection device, you must observe EN 60204-1:2006 chapter 7.5 .



Observe electrostatically sensitive components!

The devices contain electrostatically sensitive components which may be damaged by incorrect handling. Electrostatically discharge your body before touching the device. Avoid contact with highly insulating materials (artificial fabrics, plastic film etc.). Place the device on a conductive surface.

Hot surface!



Drives may have hot surfaces during operation. The housing can reach temperatures above 80°C. Risk of minor burns! Measure the temperature, and wait until the housing has cooled down below 40 °C before touching it.

Earthing!



It is vital that you ensure that the drive is safely earthed to the PE (protective earth) busbar in the switch cabinet. Risk of electric shock. Without low-resistance earthing no personal protection can be guaranteed.

Leakage Current!

Since the leakage current to PE is more than 3.5 mA, in compliance with IEC61800-5-1 the PE connection must either be doubled or a connecting cable with a cross-section >10 mm² must be used. Deviating measures according to regional standards might be possible.

Residual current protective or monitoring devices!

MKD-C with MKD-N can cause a d.c. current in the protective earthing conductor. Where a residual current-operated protective (RCD) or monitoring (RCM) device is used for protection in case of direct or indirect contact, only an RCD or RCM of Type B is allowed on the supply side of MKD-C.

Lethal voltages!



The equipment produces high electric voltages up to 900V. Lethal danger exists at live parts of the device. Do not open or touch the equipment during operation. Keep the IP 54 cabinet doors closed during operation. Built-in protection measures such as insulation or shielding may not be removed. Work on the electrical installation may only be performed by trained and qualified personnel, in compliance with the regulations for safety at work, and only with switched off mains supply, and secured against restart.

Never undo any electrical connections to the MKD while it is live. There is a danger of electrical arcing with damage to contacts and personal injury. Wait at least 5 minutes after disconnecting the product from the supply voltages (mains supply and 24V supply) before touching potentially live sections of the equipment (such as contacts) or removing any connections.

Functional Safety

NOTICE

Safety functionality is not approved nor certified. Do not use this functionality in applications with functional safety request.

Never modify the drive!

It is not allowed to modify the drive hardware without permission by the manufacturer. Opening the housing causes loss of warranty.

3.2 Shock-hazard Protection

3.2.1 Leakage current

Leakage current via the PE conductor results from the combination of equipment and cable leakage currents. The leakage current frequency pattern includes a number of frequencies, whereby the residual-current circuit breakers definitively evaluate the 50 Hz current. For this reason, the leakage current cannot be measured using a conventional multimeter.

NOTE

Since the leakage current to PE is more than 3.5 mA, in compliance with IEC61800-5-1 the PE connection must either be doubled or a connecting cable with a cross-section >10 mm² must be used. Deviating measures according to regional standards might be possible

3.2.2 Residual current protective device (RCD)

NOTE

MKD-C with connected MKD-N and AKD-N can cause a d.c. current in the protective earthing conductor. Where a residual current-operated protective (RCD) or monitoring (RCM) device is used for protection in case of direct or indirect contact, only an RCD or RCM of Type B is allowed on the supply side of MKD-C.

In conformity with IEC 60364-4-41 – Regulations for installation and IEC 60204 – Electrical equipment of machinery, residual current protective devices (RCDs) can be used provided the requisite regulations are complied with.

The MKD-C is a 3-phase system with a B6 bridge. Therefore, RCDs which are sensitive to all currents must be used in order to detect any DC fault current.

Rated residual currents in the RCDs:

10 to 30 mA	Protection against "indirect contact" (personal fire protection) for stationary and mobile equipment, as well as for "direct contact".
50 to 300 mA	Protection against "indirect contact" (personal fire protection) for stationary equipment

If you use a selective RCD, the more intelligent evaluation process will prevent spurious tripping of the RCD.

3.2.3 Isolating transformers

When protection against indirect contact is absolutely essential despite a higher leakage current, or when an alternative form of shock-hazard protection is sought, the MKD can also be operated via an isolating transformer (schematic connection (→ # 80). A ground-leakage monitor can be used to monitor for short circuits.

NOTE

Keep the length of wiring between the transformer and the drive as short as possible.

3.3 Stop / Emergency Stop / Emergency Off

The control functions Stop, Emergency Stop and Emergency Off are defined by IEC 60204. Notes for safety aspects of these functions can be found in ISO 13849 and IEC 62061.

NOTE

The parameter DRV.DISMODE must be set to 2 to implement the different stop categories. Consult the *WorkBench Online Help* for configuring the parameter.



WARNING Vertical load can fall!

Serious injury could result when a suspended load is not properly blocked. Functional safety, e.g. with hanging load (vertical axes), requires a safely operated brake, for example by a safety control via the brake interruption input (→ # 116), in process. Depending on the requested safety level a second (external) brake must be installed.

- Add a safe mechanical blocking (for instance, a motor-holding brake).
- Set parameter MOTOR.BRAKEIMM to 1 with vertical axes, to apply the motor holding brake immediately after faults or Hardware Disable.

3.3.1 Stop

The stop function shuts down the machine in normal operation. The stop function is defined by IEC 60204.

NOTE

The Stop Category must be determined by a risk evaluation of the machine.

Stop function must have priority over assigned start functions. The following stop categories are defined:

Stop Category 0

Shut-down by immediate switching-off the energy supply to the drive machinery (this is an uncontrolled shut-down). With the safety function STO the drive can be stopped using its internal electronics (IEC 62061 SIL2).

Stop Category 1

A controlled shut-down, whereby the energy supply to the drive machinery is maintained to perform the shut-down, and the energy supply is only interrupted when the shut-down has been completed.

Stop Category 2

A controlled shut-down, whereby the energy supply to the drive machinery is maintained.

Stop Category 0 and Stop Category 1 stops must be operable independently of the operating mode, whereby a Category 0 stop must have priority.

If necessary, provision must be made for the connection of protective devices and lock-outs. If applicable, the stop function must signal its status to the control logic. A reset of the stop function must not create a hazardous situation.

3.3.2 Emergency Stop

The Emergency Stop function is used for the fastest possible shutdown of the machine in a dangerous situation. The Emergency Stop function is defined by IEC 60204. Principles of emergency stop devices and functional aspects are defined in ISO 13850.

The Emergency Stop function will be triggered by the manual actions of a single person. It must be fully functional and available at all times. The user must understand instantly how to operate this mechanism (without consulting references or instructions).

NOTE

The Stop Category for the Emergency Stop must be determined by a risk evaluation of the machine.

In addition to the requirements for stop, the Emergency Stop must fulfil the following requirements:

- Emergency Stop must have priority over all other functions and controls in all operating modes.
- The energy supply to any drive machinery that could cause dangerous situations must be switched off as fast as possible, without causing any further hazards (Stop Category 0) or must be controlled in such a way, that any movement that causes danger, is stopped as fast as possible (Stop Category 1).
- The reset must not initiate a restart.

3.3.3 Emergency Off

The Emergency Off function is used to switch-off the electrical power supply of the machine. This is done to prevent users from any risk from electrical energy (for example electrical impact). Functional aspects for Emergency Off are defined in IEC 60364-5-53.

The Emergency Off function will be triggered by the manual actions of a single person.

NOTE

The result of a risk evaluation of the machine determines the necessity for an Emergency Off function.

Emergency Off is done by switching off the supply energy by electro-mechanical switching devices. This results in a category 0 stop. If this stop category is not possible in the application, then the Emergency Off function must be replaced by other measures (for example by protection against direct touching).

3.4 Use as Directed

The MKD-C series power supplies are exclusively intended for operating MKD-N servo drive modules within a cabinet and AKD-N decentralized servo drives.

The MKD-N family of servo drives is exclusively intended for driving suitable synchronous servomotors with closed-loop control of torque, speed, and/or position.

MKD system modules are components that are built into electrical plants or machines and can only be operated as integral components of these plants or machines. The manufacturer of the machine must generate a risk assessment for the machine.

When the system modules are built into machines or plant, the drive must not be used until it has been established that the machine or plant fulfills the requirements of the regional directives.

Kollmorgen multi axes drive system

MKD must only be operated in a motion system with components from Kollmorgen. Required additional Kollmorgen components are the mains chokes, hybrid string cables, hybrid motor cables, motor power and feedback cables, servomotors.

Assembling

MKD modules must only be operated in environments suitable for the ambient conditions defined on (→ # 38).

Wiring

Use only Kollmorgen cables for connecting the system components.

Power supply

MKD-C must be powered from a 3 phase industrial supply network (not more than 42 kA symmetrical rated current at 400 V and 480 V) via a mains choke 3YL.

MKD-N series drives must be powered by MKD-C intelligent power supply modules with DC voltage from 55 VDC up to 800 VDC.

Fusing

The devices must be operated with fuse protection against power overload.

Motor voltage rating

The rated voltage of the motors must be at least as high as the DC bus link voltage divided by $\sqrt{2}$ produced by the drive ($U_{nMotor} \geq U_{DC} / \sqrt{2}$).

For the cases of group installations and of DC powered drives

NOTICE

MKD has not been evaluated by Kollmorgen, UL, or TÜV for group installations nor are ratings defined for DC input voltage.

Auxiliary voltage supply, Standby power

Standby power for the drive strings must only be used for supplying the MKD-N electronics. 24 VDC supply unit must accord to PELV (EN 60204-1) requirements.

Safe torque off

NOTICE

Safety functionality is not approved nor certified. Do not use this functionality in applications with functional safety request.

3.5 Prohibited Use

Other use than that described in chapter “Use as directed” is not intended and can lead to personnel injuries and equipment damage.

The system may not be used

- with a machine that does not comply with appropriate national directives or standards,
- for driving elevators,
- in applications with continuous, operational short circuits to the external regen resistor contacts.
- in applications with any short circuits to the DC-Bus link contacts.

The use of the device in the following environments is also prohibited:

- potentially explosive areas
- environments with corrosive and/or electrically conductive acids, alkaline solutions, oils, vapors, dusts
- ships or offshore applications



Wiring the system with hybrid cables from other manufacturers than Kollmorgen is not allowed. Changing Kollmorgen cables or connectors is not allowed.

3.6 Warning note labels

NOTICE

If these signs are damaged, they must be replaced immediately.

3.6.1 Notes placed on the product

 <p>The minimum size of the protective earthing conductor shall comply with the local safety regulations for high protective earthing conductor current.</p>	 <p>Residual Voltage Wait 5 minutes after removing power before servicing.</p>
---	--

4 Product life cycle handling

4.1 Packaging	23
4.2 Transport	23
4.3 Storage	23
4.4 Installation, setup and normal operation	24
4.5 Decommissioning	24
4.6 Maintenance and cleaning	24
4.7 Disassembly	24
4.8 System Repair	25
4.9 Disposal	25

4.1 Packaging

The MKD packaging consists of recyclable cardboard with inserts and a label on the outside of the box.

Model	Package Dimensions (mm) HxWxL	Total Weight (kg)
MKD-C003007	580 x 350 x 170	22.5
MKD-N060007	580 x 350 x 110	8.5
MKD-N060607		
MKD-N120007		
MKD-N120607		
MKD-N121207		
MKD-N240007	580 x 350 x 110	9.5
MKD-N480007	580 x 350 x 140	11.5

4.2 Transport

Transport the MKD modules in accordance with IEC 61800-2 as follows:

- Transport only by qualified personnel in the manufacturer's original recyclable packaging.
- Avoid shocks while transporting.
- Vibration/Shock: MKD modules are tested for environmental class 3M1 of IEC 60721-3-2.
- Store at or below maximum stacking height of 8 cartons
- Transport only within specified temperature ranges: -25 to +70 °C, max. rate of change 20 K/hour, class 2K3.
- Transport only within specified humidity: maximum 95% relative humidity, no condensation, class 2K3.

NOTICE

The devices contain electrostatically sensitive components that can be damaged by incorrect handling. Electrostatically discharge yourself before touching the device. Avoid contact with highly insulating materials, such as artificial fabrics and plastic films. Place the device on a conductive surface.

If the packaging is damaged, check the unit for visible damage. Inform the shipper and the manufacturer of any damage to the package or product.

4.3 Storage

Store the MKD modules in accordance with IEC 61800-2 as follows:

- Store only in the manufacturer's original recyclable packaging.
- Store at or below maximum stacking height of 8 cartons
- Store only within specified temperature ranges: -25 to +55 °C, max. rate of change 20 K/hour, class 1K4.
- Storage only within specified humidity: 5 to 95% relative humidity, no condensation, class 1K3.
- Store the MKD in accordance with the following duration requirements:
 - Less than 1 year: without restriction.
 - More than 1 year: capacitors in the MKD-C must be re-formed before setting up and operating the system. Re-forming procedures are described in the Kollmorgen Developer Network ([Forming](#)).

4.4 Installation, setup and normal operation

Installation and setup information are given in this manual:

- Mechanical installation (→ # 49)
- Electrical installation (→ # 53)
- Setup (→ # 117)

Normal operation tested for environmental class 3K3 according to IEC 61800-2 (→ # 38).

The manufacturer of the machine defines the necessary end user expertise based on the risk assessment for the machine and describes the requirements for normal operation based on the application.

4.5 Decommissioning

NOTICE

Only professional staff who are qualified in electrical engineering are allowed to decommission parts of the system.

DANGER: Lethal Voltages!

There is a danger of serious personal injury or death by electrical shock or electrical arcing.

- Switch off the main switch of the switchgear cabinet.
- Secure the system against restarting.
- Block the main switch.
- Wait at least 5 minutes after disconnecting.

4.6 Maintenance and cleaning

The device does not require maintenance. Opening the device voids the warranty. The inside of the unit can only be cleaned by the manufacturer.

NOTICE

Do not immerse or spray the device. Avoid that liquid enters the device.

To clean the device exterior:

1. Decommission the device (see chapter 4.5 "Decommissioning").
2. Casing: Clean with isopropanol or similar cleaning solution.
 - Caution :** Highly Flammable! Risk of injury by explosion and fire.
 - Observe the safety notes given on the cleaning liquid package.
 - Wait at least 30 minutes after cleaning before putting the device back into operation.
3. Protective grill on fan: Clean with a dry brush.

4.7 Disassembly

NOTICE

Only professional staff who are qualified in electrical engineering are allowed to disassemble parts of the system.

1. Decommission the device (see chapter 4.5 "Decommissioning").
2. Check temperature.
 - CAUTION:** High Temperature! Risk of minor burns. During operation, the heat sink of the drive may reach temperatures above 80 °C (176 °F). Before touching the device, check the temperature and wait until it has cooled below 40 °C (104 °F).
3. Remove the connectors. Disconnect the potential earth connection last.
4. Demount: loosen the fastening screws. Remove the device.

4.8 System Repair

NOTICE

Only professional staff who are qualified in electrical engineering are allowed to exchange parts of the drive system.

CAUTION: Automatic Start! During replacement work a combination of hazards and multiple episodes may occur.

- Work on the electrical installation may only be performed by trained and qualified personnel, in compliance with the regulations for safety at work, and only with use of prescribed personal safety equipment.

Exchange of the device

Only the manufacturer can repair the device. Opening the device voids the warranty.

1. Decommission the device (see chapter 4.5 "Decommissioning").
2. Demount the device (see chapter 4.7 "Disassembly").
3. Send the device to the manufacturer.
4. Install a new device as described in this manual.
5. Setup the system as described in this manual.

Exchange of other drive system parts

If parts of the drive system (for example cables) must be replaced, proceed as follows:

1. Decommission the device (see chapter 4.5 "Decommissioning").
2. Exchange the parts.
3. Check all connections for correct fastening.
4. Setup the system as described in this manual.

4.9 Disposal

NOTICE

To dispose the unit properly, contact a certified electronic scrap disposal merchant.

In accordance with the WEEE-2012/19/EC guideline and similar, the manufacturer accepts returns of old devices and accessories for professional disposal. Transport costs are the responsibility of the sender.

Contact Kollmorgen and clarify the logistics.

Send the devices in the original packaging to the manufacturer address:

North America	South America
KOLLMORGEN 201 West Rock Road Radford, VA 24141, USA	KOLLMORGEN Avenida João Paulo Ablas, 2970 Jardim da Glória, Cotia – SP CEP 06711-250, Brazil
Europe	Asia
KOLLMORGEN Europe GmbH Pempelfurtstr. 1 40880 Ratingen, Germany	KOLLMORGEN Floor 4, Building 9, No. 518, North Fuquan Road, Changning District, Shanghai 200335, China

5 Approvals

5.1	Conformance with UL/cUL	27
5.2	Conformance with EC Low Voltage and EMC Directives	27
5.3	Conformance with EC Machinery Directive, Functional Safety	27
5.4	Conformance with RoHS	27
5.5	Conformance with REACH	27

5.1 Conformance with UL/cUL

UL/cUL listing is pending.

5.2 Conformance with EC Low Voltage and EMC Directives

EU Declarations of Conformity can be found on the Kollmorgen website.

Conformance with the EC EMC Directive 2014/30/EC and the Low Voltage Directive 2014/35/EC is mandatory for the supply of drives within the European Community.

The devices have been tested by an authorized testing laboratory in a defined configuration, using the system components that are described in this documentation. Any divergence from the configuration and installation described in this documentation means that the user will be responsible for carrying out new measurements to ensure conformance with regulatory requirements.

Kollmorgen declares the conformity of the MKD modules with the following directives:

- EC Directive 2014/35/EC, Low Voltage Directive
Used harmonized standard EN61800-5-1
- EC Directive 2014/30/EC, EMC Directive
Used harmonized standard EN 61800-3

System MKD-C-NA with MKD-N

- MKD-C-NA must be powered from a 3 phase industrial supply network via a mains choke 3YL.
- The MKD modules meet the noise immunity requirements to the 2nd environmental category (industrial environment).
- For noise emission the MKD system modules meet the requirement to a product of the category C2 (motor cable up to 10 m). With a motor cable length of 10 m or more, the system meets the requirement to the category C3.

NOTICE

These devices can cause high-frequency interferences in non industrial environments and may require measures for interference suppression (additional external EMC filters).

5.3 Conformance with EC Machinery Directive, Functional Safety

NOTICE

Safety functionality is not approved nor certified. Do not use this functionality in applications with functional safety request.

5.4 Conformance with RoHS

Directive 2011/65/EC of the European Union on the restriction of the use of certain hazardous substances in electrical and electronic equipment (RoHS) became operative as from the 3rd of January, 2013. Following substances namely are involved

Lead (Pb), Cadmium (Cd), Hexavalent chromium (CrVI), Polybrominated biphenyls (PBB), Polybrominated diphenyl ethers (PBDE), Mercury (Hg)

The device is manufactured in conformance with RoHS.

5.5 Conformance with REACH

EU Regulation no. 1907/2006 deals with the registration, evaluation, authorization and restriction of chemical substances 1 (abbreviated to "REACH").

The device does not contain any substances (CMR substances, PBTsubstances, vPvB substances and similar hazardous substances stipulated in individual cases based on scientific criteria) above 0.1 mass percent per product that are included on the candidate list.

6 Package

6.1 Package Supplied	29
6.2 Nameplate	30
6.3 Part Number Scheme	31

6.1 Package Supplied

Available MKD Modules

Variant	Description	Power	Remarks
MKD-C003007-NAEC	Central Power supply	30 kW	Standard
MKD-N060007-DSEC	Drive Module	2.5 kW	Single Axis, 6A
MKD-N060607-DSEC	Drive Module	5 kW	Dual Axes, 2 x 6A
MKD-N120007-DSEC	Drive Module	5 kW	Single Axis, 12A
MKD-N120607-DSEC	Drive Module	7.5 kW	Dual Axes, 12A + 6A
MKD-N121207-DSEC	Drive Module	10 kW	Dual Axes, 2 x 12A
MKD-N240007-DSEC	Drive Module	10 kW	Single Axis, 24A
MKD-N480007-DSEC	Drive Module	20 kW	Single Axis, 48A

When a MKD module is ordered, the following items are included in the package:

MKD-C package:

- The ordered module itself
- Printed copy of *MKD Product Safety Guide*
- DVD containing the setup software, WorkBench, and all product documentation in digital format.
- Mating connectors MKD-C: X12, X13, X14, X15, X16, X25
- One MKD-N DC-Bus link cover
- Two connector covers M23 for AKD-N

NOTE

The M23 connector covers are required for protecting X2 of the last AKD-N in the strings.

MKD-N package:

- The ordered module itself
- Data Sheet
- Mating connectors MKD-N: X9, X24, X26

Accessories:

Accessories must be ordered separately if required.

- Mains choke (→ # 129)
- External regen resistor (→ # 130)
- Cables (→ # 132)
- Cabinet grommets (→ # 87)

Accessories for AKD-N see regional *Accessories Manual* or *AKD-N Installation Manual*.

Spare parts

- Connector Kit MKD-C-Conkit (X12, X13, X14, X15, X16, X25)
- Connector Kit MKD-N-Conkit 6 to 12 A single (X9, X24, X26, X29A)
- Connector Kit MKD-N-Conkit 6 to 12 A double (X9, X24, X26, X29A, X29B)
- Connector Kit MKD-N-Conkit 24 to 48 A (X9, X24, X26, X29A, X30A)

6.2 Nameplate



The nameplates depicted below are attached to the side of the device. Pictures are similar to the nameplates on the device.

6.2.1 MKD-C modules

KOLLMORGEN Customer Support: HW Rev: A 

North America: +1 (540) 633-3400
 Europe: +49 (0) 2102-9394-0
 Italy: +39 (0) 362-594260

Pempelfurtstr. 1
 40880 Ratingen
 Germany



Model No: MKD-C003007-NAEC-E000

Serial No: D-1735-20000

MAC-Address: 00.23.1B.01.10.6E

	Control Circuit	Input-Main	Output-DC-Bus
Voltage	24 Vdc	400 Vac	565-680 Vdc
Frequency	-	50/60 Hz	dc
Phase	-	3 Ph	1 Ph
FL Current	max 10 A dc	8 Arms	10 Arms
Power @ 400Vac		5,6 kVA	5,6 KW

Surrounding Air Temperature: max. 40 °C SCCR: 42kA
 Enclosure Protection Rating: IP20

Before use, refer to documents for installation and safety.
 Assembled in Germany Patents Pending www.kollmorgen.com

6.2.2 MKD-N modules

KOLLMORGEN Customer Support: HW Rev: A 

North America: +1 (540) 633-3400
 Europe: +49 (0) 2102-9394-0
 Italy: +39 (0) 362-594260

Pempelfurtstr. 1
 40880 Ratingen
 Germany

Model No: MKD-N060007-DSEC-E000

Serial No: D-1850-20017

DC-Input	Output	axis 1	axis 2
Voltage 560-680 Vdc	MAC-Address 00:23:1B:30:5F:75		
Frequency -	Voltage 0-480 Vac		
Phase -	Frequency 0-600 Hz		
FL Current 5,5 A dc	Phase 3 Ph		
Power 1,5kVA	FL Current 6 Arms		
	Base Frequency 8 kHz		

Surrounding Air Temperature: Max. 40°C
 Enclosure Protection Rating: IP 20

Before use, refer to documents for installation and safety.
 Patents Pending www.kollmorgen.com





6.3 Part Number Scheme

Use the part number scheme for product identification only, not for the order process, because not all combinations of features are possible, always.

6.3.1 MKD-C modules

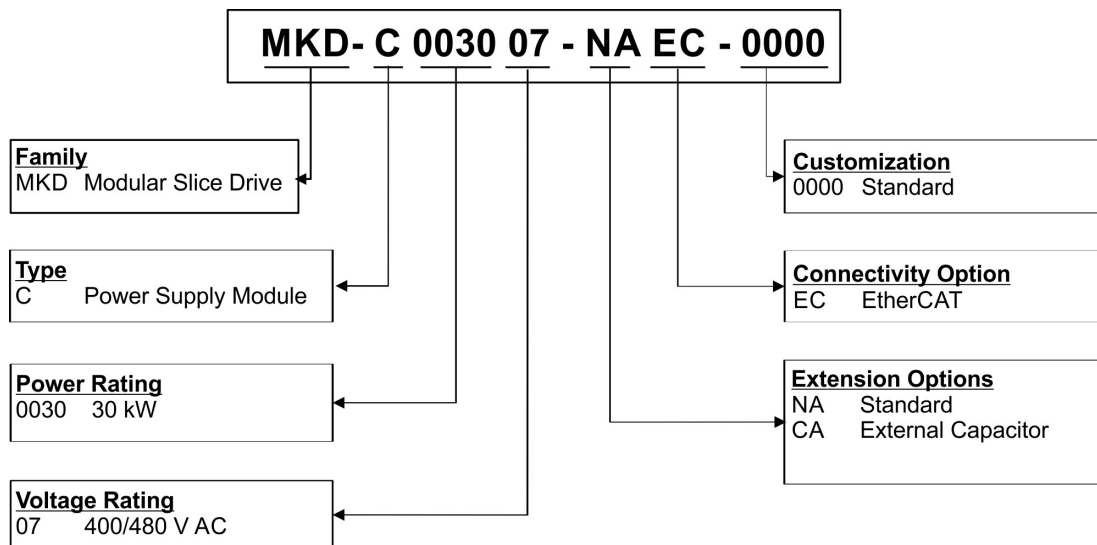

Customization code coding for customer specials (not relevant for functional safety).

6.3.2 MKD-N modules

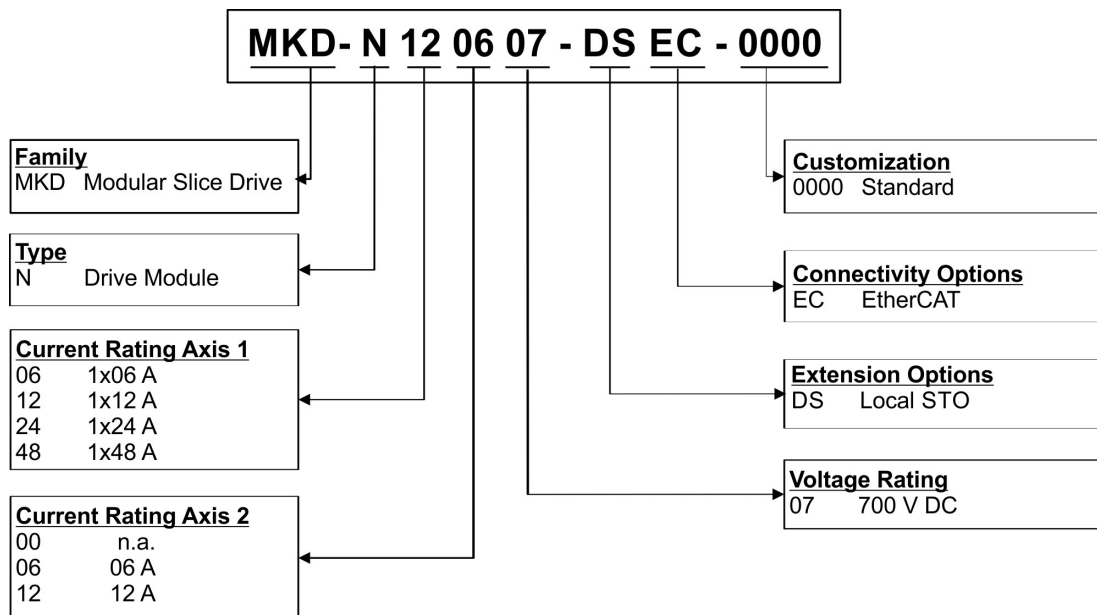

Available drive modules:

Single Axis	Current rating		Dual Axes	Current rating	
	Axis 1	Axis 2		Axis 1	Axis 2
MKD-N0600	06 A	-	MKD-N0606	06 A	06 A
MKD-N1200	12 A	-	MKD-N1206	12 A	06 A
MKD-N2400	24 A	-	MKD-N1212	12 A	12 A
MKD-N4800	48 A	-			

Customization code coding for customer specials (not relevant for functional safety).

7 Technical description and data

7.1	The MKD Multi Axes System	33
7.2	Mechanical Data	34
7.3	Performance Data	34
7.4	Electrical Data	35
7.5	Fusing	37
7.6	Ambient Conditions in normal operation	38
7.7	Ground System	38
7.8	Connectors	39
7.9	Recommended Tightening Torques	40
7.10	Cable Requirements	41
7.11	Cable Length Definition	43
7.12	Dynamic Braking	44
7.13	Regen circuit	44
7.14	LED signals	45
7.15	Push-button (B1)	47
7.16	Rotary Switch (S1), Setting IP address	48

7.1 The MKD Multi Axes System

Standard features

MKD-C	MKD-N
<ul style="list-style-type: none"> • Supply voltage 400 V to 480 V $\pm 10\%$. • Mains EMC filter and 24 V EMC filter integrated. • EtherCAT bus onboard. • TCP/IP service channel 100 Mbit/s onboard. • Safe Torque Off (STO) according to IEC 62061 SIL 2 onboard. • Supports up to 42 drive axes. 	<ul style="list-style-type: none"> • Supply voltage 55 VDC to 800 VDC • Motion bus onboard. • SFD3, ENDAT 2.1 & 2.2, BiSS, HIPERFACE DSL • Local Safe Torque Off (STO) according to IEC 62061 SIL 2 onboard. • Use with synchronous servomotors, linear motors, and induction machines.

Power section

MKD-C	MKD-N
<ul style="list-style-type: none"> • Three phase supply, maximum voltage range 360 to 528 V, 47 to 65 Hz. • B6 bridge rectifier, integral soft-start circuit. • Fusing to be provided by the user. • DC power split to three connectors (strings) for up to 42 drive axes. • DC power voltage range 565 to 680 VDC • Standby DC string power voltage 55 VDC $\pm 10\%$ (generated from 24 VDC) • Regen circuit for all connected drive modules. • External regen resistor if required. 	<ul style="list-style-type: none"> • DC power supply, voltage range 55 VDC to 800 VDC. • Output stage IGBT module with floating current measurement.

Integrated safety

- Appropriate insulation/creepage distances and electrical isolation for safe electrical separation, per IEC 61800-5-1, between the power input/DC bus connections and the signal electronics.
- Soft-start, overvoltage detection, short-circuit protection, phase-failure monitoring.
- Temperature monitoring.
- SIL 2 safe torque off in accordance with IEC 62061, (\rightarrow # 105).
- Safe Brake Interruption for realization of SBC up to SIL2/PLd

Supply voltage 24V DC (electronic supply and standby voltage)

- From an external, 24 V $\pm 10\%$ PELV power supply, minimum 1 kW.

STO voltage 24V DC (functional safety circuits)

- From an external, 24 V $\pm 10\%$ PELV power supply, or from safety controller. Power depends on application.

Operation and parameter setting

- Using the setup software WorkBench for setup via TCP/IP.

Full digital control MKD-N

- Digital current controller (670 ns)
- Adjustable digital velocity controller (62.5 μ s)
- Software option position controller (250 μ s)

Inputs/Outputs

MKD-C	MKD-N
<ul style="list-style-type: none"> • 1 programmable digital output • 1 programmable relay output (fault) • 1 Enable input • 2 programmable digital inputs • 2 STO inputs (one per string) • 2 STO status outputs (one per string) • Service Interface • EtherCAT Interface 	<ul style="list-style-type: none"> • 6 programmable digital inputs (3 per axis) • 2 programmable digital output (one per axis) • 2 STO inputs (one per axis) • 2 STO status outputs (one per axis) • Two wire feedback interface (SFD3, DSL) • Conventional feedback interface • Secondary feedback interface

7.2 Mechanical Data

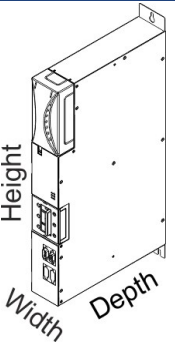
	Units	MKD-C	MKD-N									
		-NA	6A	6A 6A	12A	12A 6A	12A 12A	24A	48A			
	Weight	kg	20	5.6	6.1	5.8	6.3	6.5	7.3	9.2		
	Height, without connectors	mm	450	450								
	Height, with connectors	mm	800	500					590			
	Width	mm	130	65						100		
	Depth, without connectors	mm	260	260								
	Depth, with connectors	mm	260	300								

7.3 Performance Data

Performance Data	Units	MKD-N 6...12A	MKD-N 24...48A
Switching frequency of output stage	kHz	8	
Voltage rise speed dU/dt	kV/ μ s	7.2	
Bandwidth of current controller	kHz	2.5	
Bandwidth of velocity controller (scalable)	Hz	0 to 750	0 to 600
Bandwidth of position controller (scalable)	Hz	1 to 250	
Maximum motor frequency	Hz	599	

7.4 Electrical Data

7.4.1 MKD-C

Electrical data	Units	MKD-C-NA
Rated supply voltage (L1, L2, L3)	V~	3 x 400 V to 3 x 480 V, $\pm 10\%$
Rated supply input frequency	Hz	50 Hz / 60 Hz
Rated input power	kVA	30
Rated input current		
at 3x400 V~	A	44
at 3x480 V~	A	36
Permitted switch on/off frequency, mains	1/h	30
Max. inrush current	A	20
Rated DC bus link voltage (Bus Turn on Delay 3ph 1 sec)	VDC	565 to 680
Standby DC power voltage	VDC	55 $\pm 10\%$
Continuous total output current		
at 565 VDC	A=	53
at 680 VDC	A=	44
Peak total output current (for 1 s, $\pm 3\%$)		
at 565 VDC	A=	159
at 680 VDC	A=	132
Continuous output power	kVA	30
Output power (per string)		
continuous	kVA	10
peak (for 1 s)	kVA	30
Peak total output power (1s, D=0.25)	kVA	90
Technical data for regen circuit	—	(→ # 44)
Thermal dissipation at 24V standby		
No drive axis (min)	W	8.6
42 drive axes (max)	W	70
Thermal dissipation at rated current (without regen power)	W	250
Noise emission (low speed / high speed fan)	dB(A)	40 / 60
Aux. voltage supply (PELV)	VDC	24 V ($\pm 10\%$, check voltage drop)
Aux. voltage supply current		
maximum required	A=	40
per axis without brake	A=	0.33
Aux. voltage inrush current	A=	16
Protection class	-	IP20

7.4.2 MKD-N, single axis

Electrical data	Units	MKD-N0600	MKD-N1200	MKD-N2400	MKD-N4800
Rated supply voltage	VDC	565 to 680			
Standby supply voltage	VDC	55			
Rated input power for continuous operation	kVA	2.6	4.5	8.5	16.3
Rated input current at 565 VDC	A	4.6	8.1	15.3	30.8
Rated input current at 680 VDC	A	3.8	6.7	12.7	25.4
Continuous output current ($\pm 3\%$)					
Axis	Arms	6	12	24	48
Module	Arms	6	12	24	48
Peak output current (for 5 s, $\pm 3\%$)					
Axis	Arms	18	30	48	96
Module	Arms	18	30	48	96
Continuous output power	kW	2.5	5	10	20
Peak output power (for 5 s)	kW	7.5	12.5	20	40
Motor inductance min.	mH	3.2	2.5	1.2	0.6
Motor inductance max.	mH	300	250	120	60
Thermal dissipation, output stage disable	W	tbd	tbd	tbd	tbd
Thermal dissipation at rated current	W	tbd	tbd	tbd	tbd
Efficiency factor	%	tbd	tbd	tbd	tbd
Motor holding brake current	A	max. 1.6	max. 1.6	max. 2.2	max. 2.2

7.4.3 MKD-N, dual axis

Electrical data	Units	MKD-N0606	MKD-N1206	MKD-N1212
Rated supply voltage	VDC	565 to 680		
Standby supply voltage	VDC	55		
Rated input power for continuous operation	kVA	4.5	6.5	8.5
Rated input current at 565 VDC	A	8.1	11.7	15.3
Rated input current at 680 VDC	A	6.7	9.7	12.7
Continuous output current ($\pm 3\%$)				
Axis 1 / 2	Arms	6 / 6	12 / 6	12 / 12
Module	Arms	12	18	24
Peak output current (for 5 s, $\pm 3\%$)				
Axis 1 / 2	Arms	18 / 18	18 / 30	30 / 30
Module	Arms	36	48	60
Continuous output power	kW	5	7.5	10
Peak output power (for 5 s)	kW	15	20	25
Motor inductance min.	mH	3.2 / 3.2	2.5 / 3.2	2.5 / 2.5
Motor inductance max.	mH	300 / 300	250 / 300	250 / 250
Thermal dissipation, output stage disable	W	tbd	tbd	tbd
Thermal dissipation at rated current	W	tbd	tbd	tbd
Efficiency factor	%	tbd	tbd	tbd
Motor holding brake current	A	max. 1.6 / 1.6	max. 1.6 / 1.6	max. 1.6 / 1.6

7.5 Fusing

7.5.1 External power supply and 24 V fusing

NOTE

Non renewable cartridge fuses must be used with finger safe fuse holders according to IEC 60529.

UL cartridge fuses: Class J, 600 VAC 200 kA, time-delay. The fuse must be UL and CSA listed, UL recognized is not sufficient.

CE cartridge fuses: types gS(gRL) or gG, 400 V/500 V, time-delay

Cartridge Fuses	Ampere rating	UL Region	CE Region
External AC power supply fusing (FN1/2/3)	60 A (Time-Delay)	example Mersen: AJT 60, 60A	example Siba: type gS/gG, D02, 63A
External 24 VDC supply fusing (FA1)	40 A (Time-Delay)	example Mersen: TR40R, 40A	example Mersen: D02GG40V40/10, 40A

Ampere rating for operation with full application power. Low coincidence factor may allow reduction of fuse ampere rating.

7.5.2 External regen resistor fusing

FPS: Frizlen DC Powerswitch



RBext	FPS	Range [In]	cable cross section
BAS(U)2000-10	FPS-16	10 to 16 A	min. 2.5 mm ²
BAS(U)3000-10	FPS-20	16 to 20 A	min. 4 mm ²
BAS(U)6000-10	FPS-25	20 to 25 A	min. 4 mm ²

7.5.3 DC-Bus link fusing

NOTICE

DC Bus sharing functionality is pending. Do not use this functionality until further notice.

7.6 Ambient Conditions in normal operation

Storage, Transport	(→ # 23)
Normal operation	Environmental class 3K3 according to IEC 61800-2
Surrounding air temperature in operation	0 to +40 °C under rated conditions +40 to +55 °C with continuous current derating 4 % per Kelvin
Humidity in operation	Relative humidity 5 to 85%, no condensation, class 3K3
Site altitude	Up to 1000 meters above mean sea level without restriction 1,000 to max. 2,000 meters above mean sea level with power derating 1.5%/100 m
Pollution level	Pollution level 2 as per IEC 60664-1
Vibrations	Class 3M1 according to IEC 60721-3-3
Environmental area	Cabinet IP 54 according to IEC 60529
Mounting position	Vertical
Ventilation	Built-in fan.
 CAUTION	Continuous noise up to 60dBA during operation. Keep cabinet doors closed during operation. To reduce inconvenience, we suggest to use ear protection if cabinet doors must be opened during normal operation.
 NOTICE	The device shuts down in case of excessively high temperature in the control cabinet. Make sure sufficient forced ventilation is supplied within the control cabinet.

7.7 Ground System

There are several ground networks in the device:

MKD-C	X15	DCOM	common line for digital inputs on I/O connector
MKD-C	X13	GND	24 V supply ground
MKD-C	X16	STO-GND	STO 24 V ground
MKD-C	X18	0 V	internal digital ground, service channel
MKD-N	X24	DCOM	common line for digital inputs on I/O connector
MKD-N	X26	STO-GND	STO 24 V ground

7.8 Connectors

Given voltage and current data are the lowest values allowed by UL and CE.

NOTE

- Connector pinout (→ # 71).
- Recommended cable cross sections and wiring details (→ # 41).
- Cable length restrictions (→ # 43).

MKD-C connectors

#	Connector	Type	Max. Cross Section ¹⁾	Current ²⁾	Voltage ³⁾
X10	EtherCAT	RJ45	0,5 mm ² , 21 awg	1 A	<100 V
X11	EtherCAT	RJ45	0,5 mm ² , 21 awg	1 A	<100 V
X12	Power	4 screw terminals	35 mm ² , 2 awg	125 A	1000 V
X13	Aux. voltage	2 screw terminals	10 mm ² , 8 awg	41 A	1000 V
X14	Regen resistor	4 screw terminals	10 mm ² , 8 awg	41 A	1000 V
X15	Control signals	2x6 push lock terminals	1.5 mm ² , 16 awg	12 A	150 V
X16	Global STO signals	2x6 push lock terminals	1.5 mm ² , 16 awg	12 A	150 V
X18	Service Port	RJ45	0,5 mm ² , 21 awg	1 A	<100 V
X20	DC Power String 2/3	3 screw terminals each	10 mm ² , 8 awg	41 A	1000 V
X21	Fieldbus String 2/3	Mini I/O, 8 poles each	0.34 mm ² , 22 awg	0.5 A	30 V
X22	Fieldbus Out String 1	RJ45	0,5 mm ² , 21 awg	1 A	<100 V
X23	DC Bus Bar	3 sliding contacts	-	100 A	600 V
X25	DC Bus Share	2 screw terminals	16 mm ² , 6 awg	76 A	1000 V

MKD-N connectors

#	Connector	Type	Max. Cross Section ¹⁾	Current ²⁾	Voltage ³⁾
X9	Brake Interruption	2 push lock terminals / axis	1.5 mm ² , 16 awg	12 A	150 V
X23	DC Bus Bar	3 sliding contacts	-	100 A	600 V
X24	Digital I/O	8 push lock terminals / axis	1.5 mm ² , 16 awg	12 A	150 V
X26	Local STO	6 push lock terminals / axis	1.5 mm ² , 16 awg	12 A	150 V
X27	Fieldbus In String 1	RJ45	0,5 mm ² , 21 awg	1 A	<100 V
X28	Fieldbus Out String 1	RJ45	0,5 mm ² , 21 awg	1 A	<100 V
X29	Motor Power+Brake, 6A/12A modules	6 screw terminals / axis	10 mm ² , 8 awg	41 A	1000 V
X29	Motor Power, 24A/48A modules	4 screw terminals / axis	16 mm ² , 6 awg	76 A	1000 V
X30	Motor Brake, 24A/48A modules	2 screw terminals	1.5 mm ² , 16 awg	12 A	150 V
X31	Feedback DSL/SFD3	1 SubD 9 (female) / axis	0,5 mm ² , 21 awg	1 A	<100 V
X32	Feedback Conventional types	1 SubD 15 HD (female) / axis	0,5 mm ² , 21 awg	1 A	<100 V
X33	Secondary Feedback	1 SubD 9 (male) / axis	0,5 mm ² , 21 awg	1 A	<100 V

1) single-line connection

2) single-line connection with recommended conductor cross section (→ # 41)

3) rated voltage with pollution level 2 (lowest values allowed by UL61800-5-1 / IEC60664)

7.9 Recommended Tightening Torques

7.9.1 MKD-C

#	Connector	Tightening Torque			
		Terminal [Nm]	Terminal [in-lbs]	Plug [Nm]	Plug [in-lbs]
X10, X11	EtherCAT	-	-	-	-
X12	Power	2.5 to 4.5	22.1 to 39.8	3.5 to 4.5	30.9 to 38.9
X13	Aux. voltage	0.7 to 0.8	6.2 to 7.1	0.7 to 0.8	6.2 to 7.1
X14	Regen resistor	1.7 to 1.8	15.0 to 15.9	0.3 to 0.7	2.6 to 6.2
X15A/B	Control signals	-	-	-	-
X16A/B	STO signals	-	-	-	-
X18	Service Port	-	-	-	-
X20A/B	DC Power String 2/3	0.7 to 0.8	6.2 to 7.1	0.3 to 0.7	2.6 to 6.2
X21A/B	Fieldbus String 2/3	-	-	-	-
X22	Fieldbus Out String 1	-	-	-	-
X23	DC Bus Bar	1.5	13.3	-	-
X25	DC Bus Share	1.7 to 1.8	15.0 to 15.9	0.3 to 0.7	2.6 to 6.2
PE Bolt	Protective Earth	1.7	15.0	-	-

7.9.2 MKD-N

#	Connector	Tightening Torque			
		Terminal [Nm]	Terminal [in-lbs]	Plug [Nm]	Plug [in-lbs]
X9A/B	Brake Interruption	-	-	-	-
X23	DC Bus Bar	1.5	13.3	-	-
X24A/B	Digital I/O	-	-	-	-
X26A/B	Local STO	-	-	-	-
X27	Fieldbus In String 1	-	-	-	-
X28	Fieldbus Out String 1	-	-	-	-
X29A/B	Motor Power + Brake, 6A/12A modules	0.7 to 0.8	6.2 to 7.1	0.3 to 0.7	2.6 to 6.2
X29A	Motor Power, 24A/48A modules	1.7 to 1.8	15.0 to 15.9	0.3 to 0.7	2.6 to 6.2
X30A	Motor Brake, 24A/48A modules	0.22 to 0.25	1.9 to 2.2	0.3 to 0.7	2.6 to 6.2
X31A/B	Feedback DSL/SFD3	-	-	0.3 to 0.5	2.6 to 4.4
X32A/B	Feedback, Conventional	-	-	0.3 to 0.5	2.6 to 4.4
X33A/B	Feedback, 2. Feedback	-	-	0.3 to 0.5	2.6 to 4.4
PE Bolt	Protective Earth	1.7	15.0	-	-

7.10 Cable Requirements

The table below describe the recommended interface cross sections and cable requirements in accordance with IEC 60204. For information on the chemical, mechanical, and electrical characteristics of the cables please contact our customer support.

NOTE

Use Kollmorgen hybrid, motor, and feedback cables only. You will lose system warranty, if you use hybrid, motor or feedback cables from a manufacturer other than Kollmorgen.

NOTE

- Connector and mating connector data (→ # 39).
- Connector pinout (→ # 71).
- Cable length restrictions (→ # 43).

7.10.1 MKD-C

Hybrid cable from	Hybrid cable to	Cross section	Cable type*
MKD-C X20A/X21A, String 2	AKD-N X1, hybrid	3 x 2.5 mm ² + 4 x 0.25 mm ²	MKC-HYB-z-AKN
MKD-C X20B/X21B, String 3	AKD-N X1, hybrid	3 x 2.5 mm ² + 4 x 0.25 mm ²	MKC-HYB-z-AKN

* Followed by length coding. Contact your Kollmorgen sales representative.

#	Interface	Cross Section	Cable Requirements
X12	AC connection	35 mm ² (2 awg)	600 V, minimum 75°C
X13	+24 V / GND	10 mm ² (8 awg)	single line
X14	Regen resistor	10 mm ² (8 awg)	1000 V, minimum 75°C, shielded for lengths >0.20 m
X15	Digital I/Os	0.5 mm ² (21 awg)	single line, e.g. H07VK
X16	STO Signals	0.5 mm ² (21 awg)	single line, e.g. H07VK
X25	DC Bus sharing	16 mm ² (6 awg)	1000 V, minimum 75°C, shielded for lengths >0.20 m

#	Interface	Cross Section	Type
X10, X11	EtherCAT	0,5 mm ² (21 awg)	RJ45 Cat 6 Ethernet cable
X18	Service Port	0,5 mm ² (21 awg)	RJ45 Cat 6 Ethernet cable
X22	Fieldbus String 1	0,5 mm ² (21 awg)	RJ45 Cat 6 Ethernet cable

7.10.2 MKD-N

#	Interface	Cross section	Cable Requirements
X24	PLC Digital I/O	0.5 mm ² (21 awg)	single line, e.g. H07VK
X29/X31 6A/12A module	Motor Power+ Motor Brake+ DSL / SFD3	4 x 1.5 mm ² + 2 x 0.75 mm ² + 2 x 0.34 mm ²	Kollmorgen hybrid motor cable, twisted pairs, shielded
X29/X30/X31 24A/48A module	Motor Power+ Motor Brake+ DSL / SFD3	4 x 10 to 16 mm ² + 2 x 1.5 mm ² + 2 x 0.34 mm ²	Kollmorgen hybrid motor cable, twisted pairs, shielded
X29	Motor Power	4 x 1.5 mm ² (16 awg) to 4 x 16 mm ² (6 awg)	600 V, minimum 75°C, shielded, capacitance < 2.25 nF (phase/phase) < 3.75 nF (phase/shield)
X29 6A/12A module	Motor Power+ Brake	4 x 1.5 mm ² (16 awg) + 2 x 0.75 mm ² (19 awg)	600 V, minimum 75°C, shielded, capacitance < 2.25 nF (phase/phase) < 3.75 nF (phase/shield)
X29/X30 24A/48A module	Motor Power+ Brake	4 x 10 mm ² (16 awg) to 4 x 16 mm ² (6 awg) + 2 x 1.5 mm ² (16 awg)	600 V, minimum 75°C, shielded, capacitance < 2.25 nF (phase/phase) < 3.75 nF (phase/shield)
X32	Motor Feedback SFD	1x2x0.25 mm ² (24 awg) 1x2x0.50 mm ² (21 awg)	twisted pairs, shielded
X32	Motor Feedback Encoder+Hall, EnDat2.1, BiSS B	7x2x0.25 mm ² (24 awg)	twisted pairs, shielded
X32	Motor Feedback EnDat2.2, BiSS C	5x2x0.25 mm ² (24 awg)	twisted pairs, shielded
X33	Secondary Feedback, Encoder	5x2x0.25 mm ² (24 awg)	twisted pairs, shielded

7.11 Cable Length Definition

NOTE

MKD-C offers two separate strings to connect up to 14 AKD-N to each of them. Maximum total cable length for each string is 100 m. For system topology information refer to (→ # 61)

Cable Type	Cable usage	Max. Length (m)
MKC-HYB-z-AKN	MKD-C X20/21 to AKD-N X1, hybrid	40
AKN-HYB-z-AKN	AKD-N X2 to AKD-N X1, hybrid	25
EtherCAT Module Cable (Cat. 6)	MKD-C X11 to MKD-N X27 MKD-N X28 to MKD-N X27	3
Communication Adapter String 2	MKD-C X21A to MKD-N X27	3
EtherCAT Master Cable	MKD-C X10 to EtherCAT Master	3
Ethernet Cable	MKD-C X18 to Personal Computer or Switch	3
MKN-...-z-...	MKD-N X29 to motor power	40
AK7-...-z-...	MKD-N X32 to motor feedback	40
CMxNA...	AKD-N X4 to motor power	5
CFxNA...	AKD-N X5 to motor feedback	5
single wire	X13, X15, X16, X24, X26	30

If total motor cable capacitance exceeds 2.25 nF (phase / phase) or 3.75 nF (phase / shield), then a motor choke must be used with cables longer than 25 m.

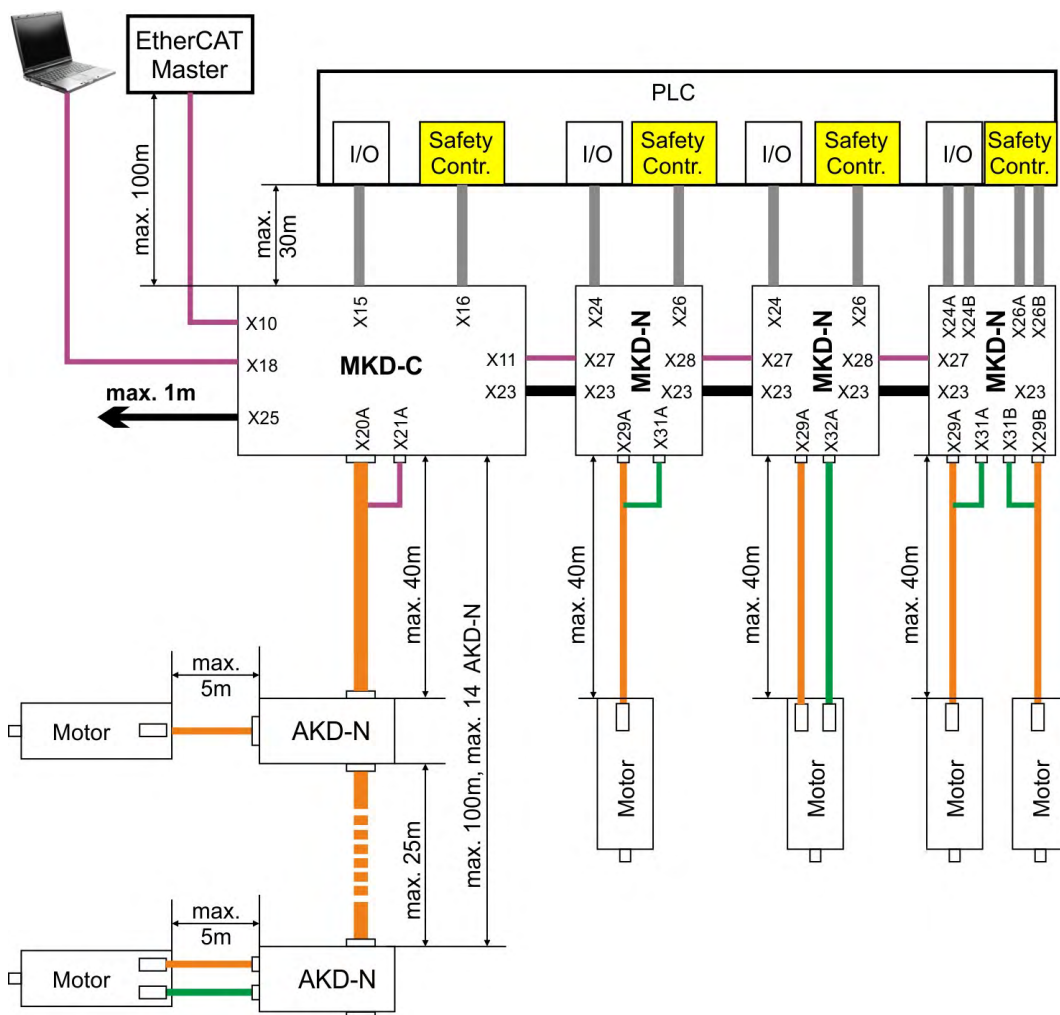

7.12 Dynamic Braking

Dynamic braking is a method to slow down a servo system by dissipating the mechanical energy driven by the motor back EMF. The MKD-N drives have a built in advanced dynamic braking mode which operates fully in hardware. When activated, the drive shorts the motor terminals in phase with the back EMF (q axis) but continues to operate the non-force producing current loop (d-axis) with 0 current. This forces all of the dynamic braking current to be stopping current and insures the fastest stopping/amp of motor terminal current.

- When current is not being limited, the mechanical energy is being dissipated in the motor resistance.
- When current is being limited, energy is returned to the MKD-C bus capacitors.
- The drive also limits the maximum dynamic braking motor terminal current via the *DRV.DBILIMIT* parameter to insure that the drive, motor, and customer load do not see excessive currents/forces.

Whether and how the MKD uses dynamic braking depends on (*DRV.DISMODE*).

7.13 Regen circuit

When the amount of returned energy from the MKD-N builds the bus capacitor voltage up enough, the MKD-C activates the regen chopper to start dumping the returned energy in the regen resistor (also called regenerative or brake resistor). An external regen resistor can be connected to MKD-C X14.

External regen resistors are described in the Appendix (→ # 130).

7.13.1 Functional description

When the amount of returned energy builds the bus capacitor voltage up enough, the MKD-C activates the regen chopper to start dumping the returned energy in the regen resistor at the MKD-C (connected to terminal X14). 90% of the combined power of all the coupled drives is always available for peak and continuous power.

The drive that has the lowest switch-off threshold (resulting from tolerances) reports an over-voltage fault if the DC bus threshold is exceeded. The drive power stage is disabled and the load coasts to a stop with the fault message "F501 Bus Over voltage" (→ # 126). The MKD-C fault relay contact (terminals X15A/1-2) is opened due to this fault.

7.13.2 Technical data

NOTE

Observe the regeneration time (some minutes) after full load with peak regen power.

Rated data	Units	400 V	480 V
Switch-on threshold of regen circuit (nominal)	V	760	760
Overvoltage limit	V	840	840
Maximum regen duty cycle	%	15*	15*
External regen resistor	Ohm	10	10
Maximum continuous regen power	kW	6	6
Regen chopper current	A	120	120
Peak regen power, external (1s)	kW	99	99
Absorption energy in capacitors (+/- 20%)	Ws	56	19
DC Bus Capacitance (nominal)	µF	1500	1500

* depends on connected regen resistor power

7.14 LED signals

The EtherCAT Status and Link/Activity LEDs functionality is specified according to the "EtherCAT Indicator Labeling Specification" defined by the EtherCAT Technology Group.

EtherCAT RUN Status (green)

LED states	Slave State
Off	INITIALISATION
Blinking	PREOPERATIONAL
Single Flash	SAFEOPERATIONAL
On	OPERATIONAL
Flickering	INITIALISATION or BOOTSTRAP

EtherCAT ERROR Status (red)

ERR State	Error Name
On	Application controller failure
n Flashes	Reserved
Triple Flash	Reserved
Double Flash	Process Data Watchdog Timeout / EtherCAT Watchdog Timeout
Single Flash	Local Error
Blinking	Invalid Configuration
Flickering	Booting Error
Off	No error

EtherCAT Link/Activity

Link	Activity	Condition	Link/Activity Code
Yes	No	Port open	On
Yes	Yes	Port open	Flickering
No	Not applicable	Port closed	Off
Yes	Yes/No	Port closed (mode needs manual open)	Inverted double flash
No	No	Local PHY auto negotiation error	Single Flash
No	No	Remote PHY auto negotiation	Double Flash
No	No	Unknown PHY auto negotiation	Triple Flash

For more information refer to the WorkBench online help.

7.14.1 MKD-C

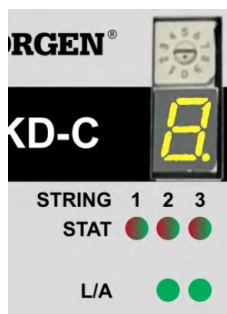

Rotary Switch

7 Segment Display

Run/Error LEDs
Link/Activity

The **LED 7-segment** display indicates the status of the drive after the 24 V supply is switched on.

MKD fault codes or warning codes are displayed constantly if present. Fault messages are coded with "F" or "E", warnings are coded with "n".

The IP address can be flashed across the 7-segment display by pressing B1 (→ # 47).

The IP address can be configured with rotary switch S1 (→ # 48).

EtherCAT STAT LEDs: There is one LED per string. As the LED is a bi-colored LED, it is used to display both the RUN (Green) and Error (RED) status.

EtherCAT L/A LEDs: These are the EtherCAT Link/Activity LEDs associated with the Motion Bus IN (X10) and OUT (X11) ports.

Activity description see table above.

7.14.2 MKD-N

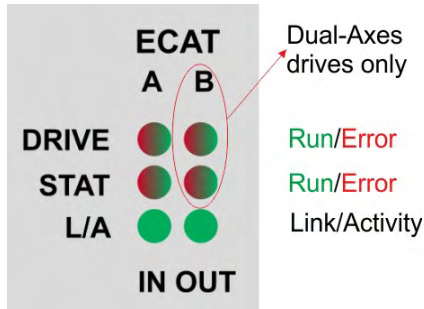

DRIVE LEDs: There is one LED per Axis. The LED delivers information with three colors (red, green, orange) and blink frequency. Specialist can analyze the blink frequency, more information to that can be found in the WorkBench online help.

Color	Remarks
Green	Enabled and running
blink green/orange	Enabled and running with warning
blink orange	Safe bus voltage
blink red/orange/green	Fault

Local Fieldbus STAT LEDs: There is one LED per Axis. As the LED is a bi-colored LED, it is used to display both the RUN (Green) and Error (RED) status.

Local Fieldbus L/A LEDs: These are the Link/Activity LEDs associated with the Local Fieldbus Bus IN (X27) and OUT (X28) ports.

Activity description see (→ #45).

7.14.3 RJ45 LED signals

MKD-C, X18 (Service)

	LED#	Name	Function
	LED1	Link	ON = active, OFF= not active
	LED2	Activity	ON = running, OFF = not running

MKD-C, X10, X11 (Motion Bus)

	LED#	Name	Function
	LED3	Link	ON = active, OFF= not active
	LED4	-	-
	LED5	Link	ON = active, OFF = not active
	LED6	-	-

MKD-C, X22 (local fieldbus out)

	LED#	Name	Function
	LED7	Link	ON = active, OFF= not active
	LED8	-	-

MKD-N, X27, X28 (local fieldbus in/out)

	LED#	Name	Function
	LED9	Link	ON = active, OFF= not active
	LED10	Activity	ON = running, OFF = not running
	LED11	Link	ON = active, OFF = not active
	LED12	-	-

7.15 Push-button (B1)

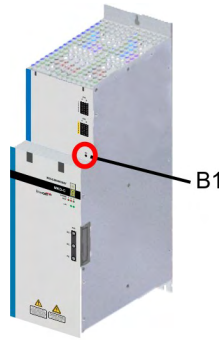

The push-button on the MKD-C can be used to start pre-defined functions.

Press short to display the IP address in the LED display

7.16 Rotary Switch (S1), Setting IP address

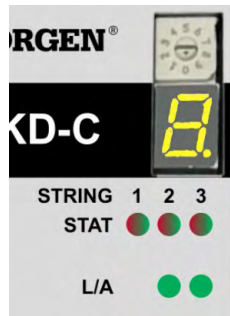

Rotary Switch

7 Segment Display

Run/Error LEDs

Link/Activity

The configured IP address (depending on the current rotary switch S1 position) will be displayed on the 7 segment at Ethernet cable connection time and at power-on, if an Ethernet cable is connected. The IP address can be flashed across the LED seven-segment display by pressing B1 (→ # 47).

If no Ethernet cable is connected, no IP address will be indicated in the display.

By default, the MKD-C utilizes the rotary switch to acquire its IP address. A method of setting the IP address independent of the rotary switch is available. More information is available in the MKD-C User Guide or in the Settings Screen-> Fieldbus-> TCP/IP screen in WorkBench.

NOTE

Set S1 to 0 (zero) for DHCP/AutoIP address.

S1 Setting	MKD-C IP Address
0	DHCP/AutoIP address. The IP address of the MKD-C is obtained from the DHCP server on your network. If no DHCP server is found the IP addresses is an AutoIP address (it is internally generated following the AutoIP protocol and will be of the form 169.254.x.x).
1 to 9	The IP address is 192.168.0.n, where n is the number set with the rotary switch. This setting generates addresses in a range from 192.168.0.1 to 192.168.0.9. Example:if S1 is set to 5 – the IP address is 192.168.0.5

NOTE

The PC subnet mask must be set to 255.255.255.0 or 255.255.255.128

Static IP addressing

When connecting the MKD-C directly to a PC, static IP addressing must be used. Set rotary switch S1 to a number from 1 to 9. This setting generates addresses in a range from 192.168.0.1 to 192.168.0.9.

Example: if S1 is set to 5, then the IP address is 192.168.0.5

Dynamic IP addressing (DHCP and Auto-IP)

With S1 set to 0, the device is in DHCP mode. The MKD-C will acquire its IP address from an external DHCP server if present in the network. If a DHCP server is not present, the MKD-C will assume an Automatic Private IP Address of the form 169.254.x.x.

If your PC or PAC is directly connected to the MKD-C, and set to obtain an IP address automatically in the TCP/IP settings, a connection will be established with both devices using compatible automatic generated addresses. It can take up to 60 seconds for a PC to configure an Automatic Private IP Address (169.254.x.x).

Changing the IP address

If the switch is altered while 24 V Logic power is supplied to the MKD-C, you must switch off and then switch on again the 24 V supply voltage. This action will reset the address.

8 Mechanical Installation

8.1 Important Notes	50
8.2 Guide to Mechanical Installation	50
8.3 Dimension Drawing	51
8.4 Mounting Example	52

8.1 Important Notes

NOTICE

MKD-C and MKD-N devices must be mounted in cabinets only with protection class IP 54 according to IEC 60529.



CAUTION High EMC Voltage Level!

Risk of electrical shock, if the servo amplifier (or the motor) is not properly EMC-grounded.

- Do not use painted (i.e. non-conductive) mounting plates.
- In unfavourable circumstances, use copper mesh tape between the earthing bolts and earth potential to deflect currents.

NOTICE

Protect the device from impermissible stresses. In particular, do not let any components become bent or any insulation distances altered during transport and handling. Avoid contact with electronic components and contacts.

NOTICE

The device will switch itself off in case of overheating. Ensure that the mounting space matches the requirements (→ # 38).

NOTICE

Do not mount devices that produce magnetic fields directly beside the device. Strong magnetic fields can directly affect internal components. Install devices which produce magnetic field with distance to the MKD-C and/or shield the magnetic fields.

8.2 Guide to Mechanical Installation

The following tools are required (at a minimum) to install the MKD-C and MKD-N modules; your specific installation may require additional tools.

- M4 hexagon socket-cap screws (ISO 4762)
- 3 mm T-handle Allen key
- No. 2 Phillips head screwdriver
- Small slotted screwdriver

For mechanical installation of AKD-N to the machine, refer to the *AKD-N Installation Manual*.

Install the modules as follows:

1. Prepare the site.
The MKD modules must be mounted in a closed control cabinet (→ # 38). The site must be free from conductive or corrosive materials. For the mounting position in the cabinet (→ # 52).
2. Check ventilation.
Check that the ventilation of the modules is unimpeded, and keep within the permitted ambient temperature (→ # 38). Keep the required space clearance above and below the modules (→ # 52).
3. Check cooling system.
If cooling systems are used for the control cabinet, position the cooling system so that condensation water cannot drip onto the modules or peripheral devices.
4. Mount the modules.
Assemble the power supply module and the drive modules on the conductive, grounded mounting plate in the cabinet.
5. Ground the modules.
For EMC-compliant shielding and grounding, (→ # 60). Ground the mounting plate, the motor housing, the GND of the 24 V supply and CNC-GND of the control system.

8.3 Dimension Drawing

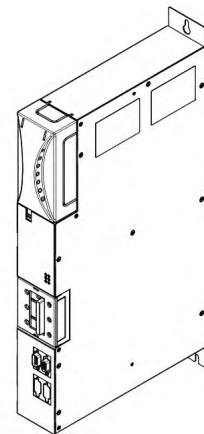
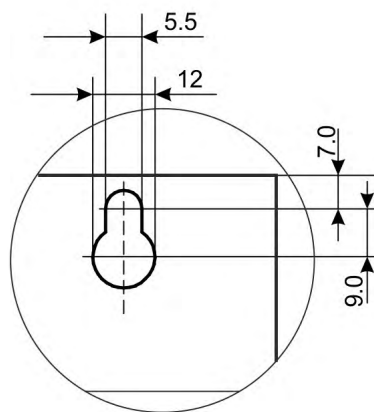
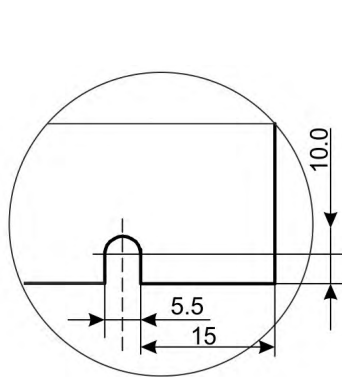
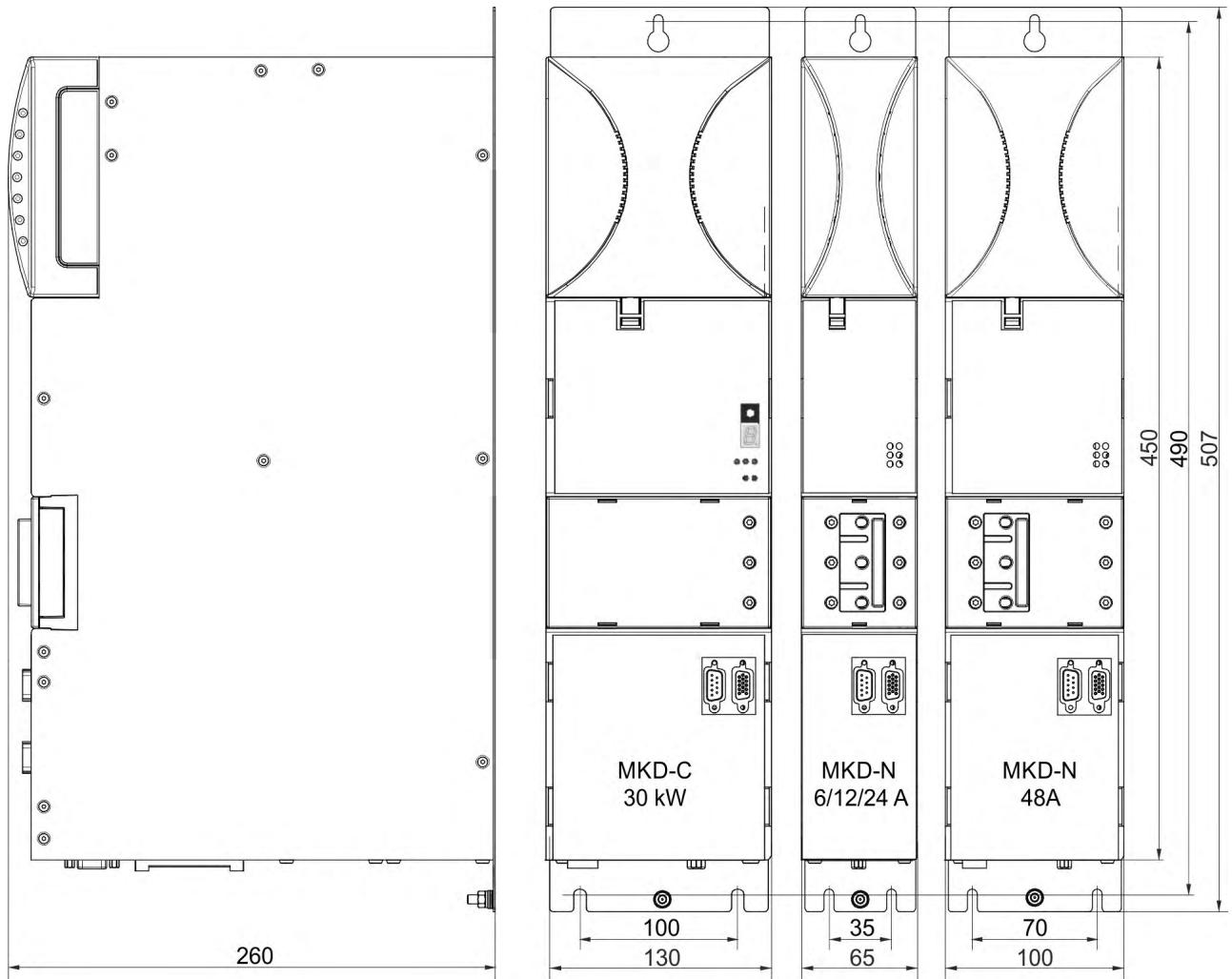

8.4 Mounting Example

Mounting material: Three M5 hexagon socket screws to ISO 4762, 4 mm T-handle Allen key.

Cabinet example: Width 600 mm, String 1 with 6 drive modules (10 axes)

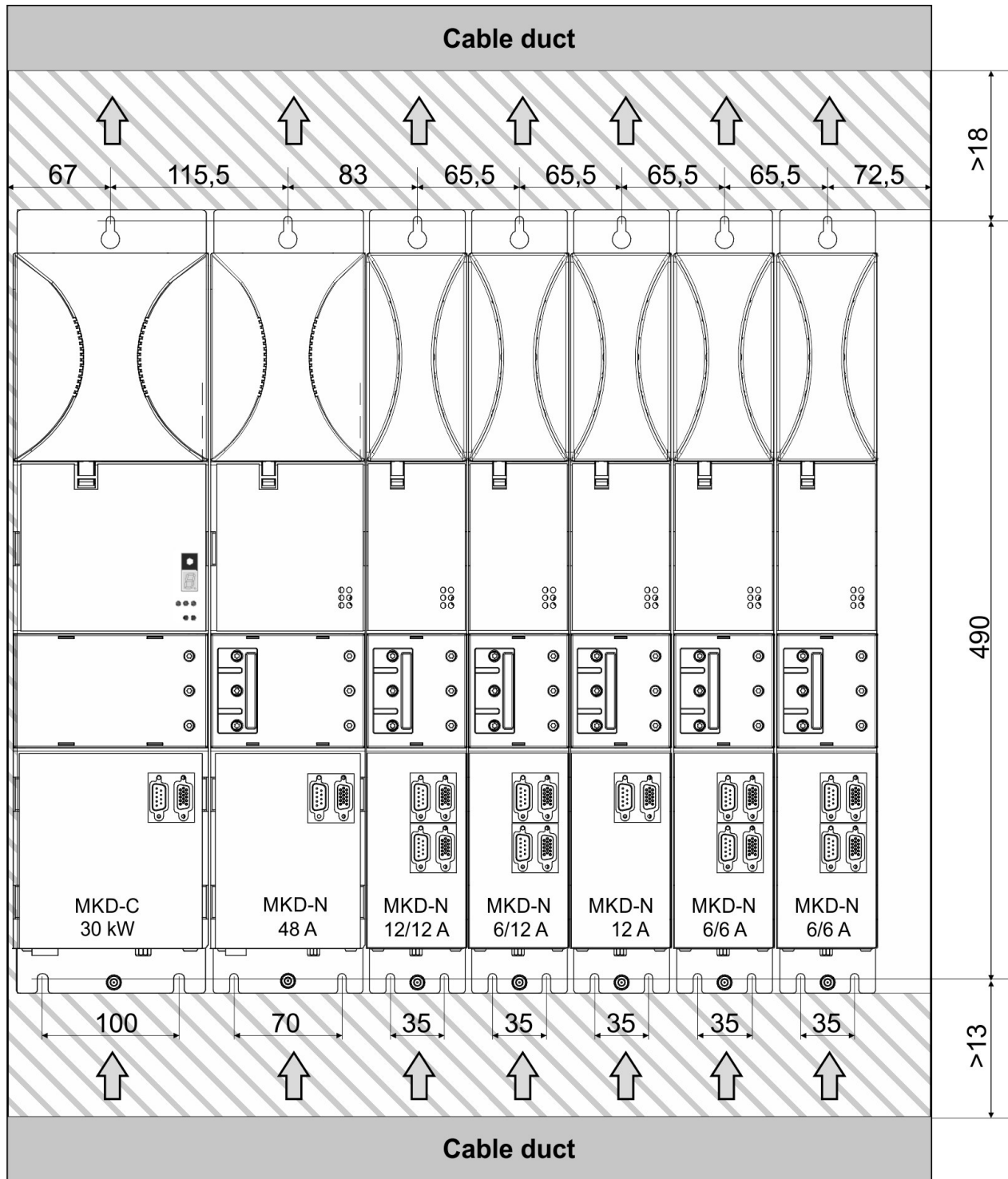

Dimensions in mm

Keep hatched space free!

9 Electrical Installation

9.1 Important Notes	54
9.2 Guide to Electrical Installation	55
9.3 Wiring	57
9.4 EMI Noise Reduction	58
9.5 System topology of an MKD drive system	61
9.6 Connection Overview	64
9.7 Electrical Supply Connection	80
9.8 DC Bus link (X20, X23, X25)	83
9.9 Motor Connection	89
9.10 Secondary Feedback Connection (X33)	95
9.11 I/O Connection	96
9.12 Motion Bus Interface (X10/X11)	103
9.13 Service Interface (X18)	104

9.1 Important Notes

NOTICE

Only professional staff who are qualified in electrical engineering are allowed to install the drive system. Wires with color green with one or more yellow stripes must not be used other than for protective earth (PE) wiring.



DANGER High Voltage up to 900 V!

There is a danger of serious personal injury or death by electrical shock or electrical arcing. Capacitors can still have dangerous voltages present up to 5 minutes after switching off the supply power. Control and power connections can still be live, even if the motor is not rotating.

- Only install and wire the equipment when it is not live.
- Make sure that the cabinet is safely disconnected (for instance, with a lock-out and warning signs).
- Never remove electrical connections to the drive while it is live.
- Wait at least 5 minutes after disconnecting the drive from the main supply power before touching potentially live sections of the equipment (e.g. contacts) or undoing any connections.
- To be sure, measure the voltage in the DC bus link and wait until it has fallen below 50 V.

NOTICE

Since the leakage current to PE is more than 3.5 mA, in compliance with IEC61800-5-1 the PE connection must either be doubled or a connecting cable with a cross-section $>10 \text{ mm}^2$ must be used. Deviating measures according to regional standards might be possible.

NOTICE

Wrong DC Bus link voltage, unsuitable motor or wrong wiring will damage the system components. Check the combination of drive and motor. Compare the rated voltage and current of the units. Implement the wiring according to the connection diagrams: (→ # 64).

NOTE

It is permissible to use the setup software to alter the settings of the device. Any other alterations will invalidate the warranty.

9.2 Guide to Electrical Installation

9.2.1 MKD-C

Remove the front protection cover:

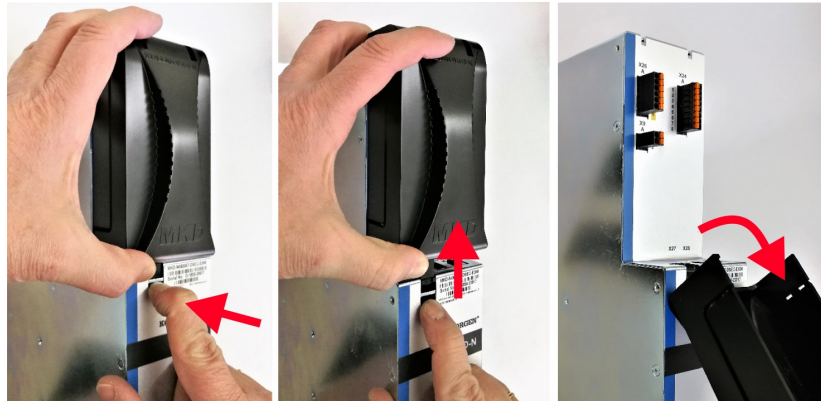

Install the power supply module as follows:

1. Select cables according to IEC 60204 (→ # 41) and the system topology (→ # 61).
2. Install shielding and ground the modules (→ # 60).
Ground the mounting plate, the 24V supply GND and CNC-GND of the control system.
3. Install digital I/O lines
4. Install Safety I/O lines
5. Wire the device.
 - a. Wire the FAULT contact in series into the emergency off circuit of the system.
 - b. If required, connect the external regen resistor (with fusing).
 - c. Connect the MKD-N drives. Close and secure all DC Bus sliders (X23).
 - d. Connect the required AKD-N drives to string 2 or string 3. For local AKD-N connections refer to the *AKD-N Installation Manual*.
 - e. Connect the digital inputs and the digital outputs, if required.
 - f. Connect the global STO inputs for the used strings (→ # 109).
 - g. Connect the local STO inputs of the used drive axes (→ # 113).
 - h. Connect the 24V power supply (required voltage value see electrical data (→ # 35)).
 - i. Connect the 24V STO power supply (PELV, required voltage values see (→ # 108)).
 - j. Connect the mains choke.
 - k. Connect the mains supply. Check maximum permitted voltage value (→ # 35).
Check proper use of residual-current circuit breakers (RCD, (→ # 17))
 - l. Connect the PC (→ # 104) for setting up the drive system.
6. Check the wiring and observe the system topology limits (→ # 61).

Reinstall the front protection cover:

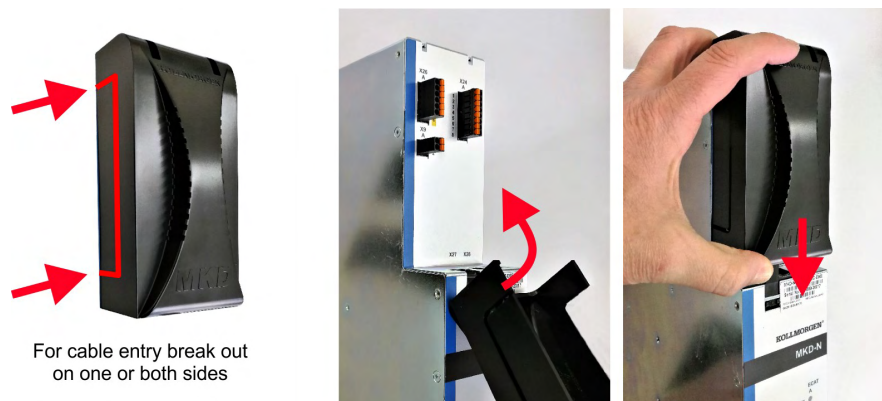

For cable entry break out
on one or both sides

9.2.2 MKD-N (string 1)

Install the drive module as follows:

1. Select cables (→ # 41) in accordance with the planned system topology (→ # 61).
2. Install grounding (PE) and ground the drive module (→ # 60). Ground the mounting plates and the motor housings.
3. Install digital I/O lines
4. Install Safety I/O lines
5. Wire the drive:
 - a. String 1 Power: close the sliding terminal (X23) to the adjacent module. Verify the position is monitored as "closed". Fasten the terminal screws.
 - b. Cover the DC Bus contacts of the last MKD-N with the DC-Bus link cover.
 - c. String 1 fieldbus: Connect the fieldbus ports of the modules (X22, X27, X28, (→ # 84))
 - d. Dual cable motor connection:
 - 6 A and 12 A axes: Connect the motor power & brake to X29, max. length 40 m.
 - 24 A and 48 A axes: Connect the motor power to X29, max. length 40 m.
 - 24 A and 48 A axes: Connect the motor brake to X30, max. length 40 m.
 - Connect the feedback to X32 , max. length 40 m.
 - e. Single cable motor connection:
 - 6 A and 12 A axes: Connect the hybrid motor power&brake to X29, max. length 40 m.
 - 24 A and 48 A axes: Connect the motor power to X29, max. length 40 m.
 - 24 A and 48 A axes: Connect the motor brake to X30, max. length 40 m.
 - Connect the hybrid motor cable feedback to X31, max. length 40 m.
6. Check the wiring against the planned system topology (→ # 61) and the wiring diagrams (→ # 68).

9.2.3 AKD-N (strings 2 or 3)

Install the drive as follows:

1. Select cables (→ # 41) in accordance with the planned system topology (→ # 61) and with *AKD-N Installation Manual*.
2. Install grounding (PE) and ground the drive, see *AKD-N Installation Manual*. Ground the mounting plates and the motor housings.
3. Wire the drive:
 - a. String 2: Connect the hybrid power cable between MKD-C X20A/X21A and first AKD-N X1, max. length 40 m.
 - b. String 3: Connect the hybrid power cable between MKD-C X20B/X21B and first AKD-N X1, max. length 40 m.
 - c. Connect the hybrid power cables between the AKD-N drives X1/X2.
 - d. Dual cable motor connection:
 - Connect the motor cable to X4, max. length 5 m.
 - Connect the feedback device to X5, max. length 5 m.
 - e. Single cable motor connection:
 - Connect the hybrid motor cable to X4, max. length 5 m.
4. Check the wiring against the planned system topology (→ # 61) and the wiring diagrams in the *AKD-N Installation manual*.

9.3 Wiring



⚠ DANGER High Voltage up to 900 V!

There is a danger of serious personal injury or death by electrical shock or electrical arcing.

- Only install and wire the equipment when it is not live, that is, when neither the electrical supply nor the 24 V auxiliary voltage nor the supply voltages of any other connected equipment is switched on.
- Make sure that the cabinet is safely disconnected (for instance, with a lock-out and warning signs). The individual voltages are switched on for the first time during setup.

NOTICE

Only professional staff who are qualified in electrical engineering are allowed to install the decentral drive system. Wires with color green with one or more yellow stripes must not be used other than for protective earth (PE) wiring. When installing or replacing cables, use only standardized components, which complies to the specifications in chapter 7.10 "Cable Requirements".

NOTE

The ground symbol, which you will find in the wiring diagrams, indicates that you must take care to provide an electrically conductive connection with the largest feasible surface area between the unit indicated and the mounting plate in the control cabinet. This connection is for the effective grounding of HF interference, and must not be confused with the PE-symbol (PE = protective earth, safety measure as per IEC 60204).

Connection Overview:

- System Topology limits & examples (→ # 61)
- Connector Position (→ # 64)
- Connection diagram MKD-C (→ # 68)
- Connection diagram MKD-N (6A, 12A) (→ # 69)
- Connection diagram MKD-N (24A, 48A) (→ # 70)
- Connector pin assignments (→ # 71)

Interface description:

- Mains supply (→ # 81)
- 24 VDC supply (→ # 82)
- DC bus link (→ # 83)
- Drive string connection (→ # 84)
- Regen resistor (→ # 88)
- Motor, Brake, Primary Feedback (→ # 89)
- Secondary Feedback (→ # 95)
- I/O connection (→ # 96)
- Motion Bus (→ # 103)
- Service interface (→ # 104)

9.4 EMI Noise Reduction



CAUTION Electromagnetic Fields!

Electromagnetic radiation may, by acting on electrically conductive materials, lead to potential hazardous danger (warming, loss of implants).

- Work on the electrical installation may only be performed by trained and qualified personnel, in compliance with the regulations for safety at work, and only with switched off mains supply, and secured against restart.
- Grounding, equipotential bonding and radiation-reducing shields may not be removed.

9.4.1 Recommendations for EMI noise reduction

The following guidelines will help you to reduce problems with electrical noise in your application.

- **Ensure cabinet is a closed cage during operation.** Use shielded protections for doors and openings in the cabinet.
- **Ensure good connections between the cabinet components.** Connect the back panel and cabinet door to the cabinet body using several conductive braids. Never rely on hinges or mounting bolts for ground connections. Ensure all DC Bus sliders are closed and secured.
- **Ensure good ground connection.** Connect from cabinet to proper earth ground. Ground leads should be the same gauge as the leads to main power or one gauge smaller.
- **Use Kollmorgen cables.** Route unshielded power and control cables separately, Kollmorgen recommends a distance of at least 200 mm to improve interference immunity.
- **Ground the shielding at both ends.** Ground all shielding with large areas (low impedance), with metalized connector housings or shield connection clamps wherever possible. For cables entering a cabinet, connect shields on all 360° of the cable. Never connect a simple “pigtail.” For more information on shielding concepts, (→ # 59).
- **Feedback lines may not be extended, since the shielding would be interrupted and the signal processing may be disturbed.** Install all feedback cables with an adequate cross-section, per IEC 60204 (→ # 41) and use the requested cable material to reach maximum cable length.
- **Splice cables properly.** If you need to divide cables, use connectors with metal shells. Ensure that both shells connect along the full 360° of the shields.
- **Cables between modules and external regen resistors must be shielded.** Install all power cables with an adequate cross-section, per IEC 60204 (→ # 41) and use the requested cable material to reach maximum cable length.

9.4.2 Shielding connection to the system modules

9.4.2.1 Ethernet connectors X10, X11, X18, X22, X27, X28

The shield of Ethernet cables is connected via the RJ45 connectors to the housing.

9.4.2.2 Power connectors with shield plate X12, X14, X20A, X20B

Connection for the DC power by mating connector with strain relief.

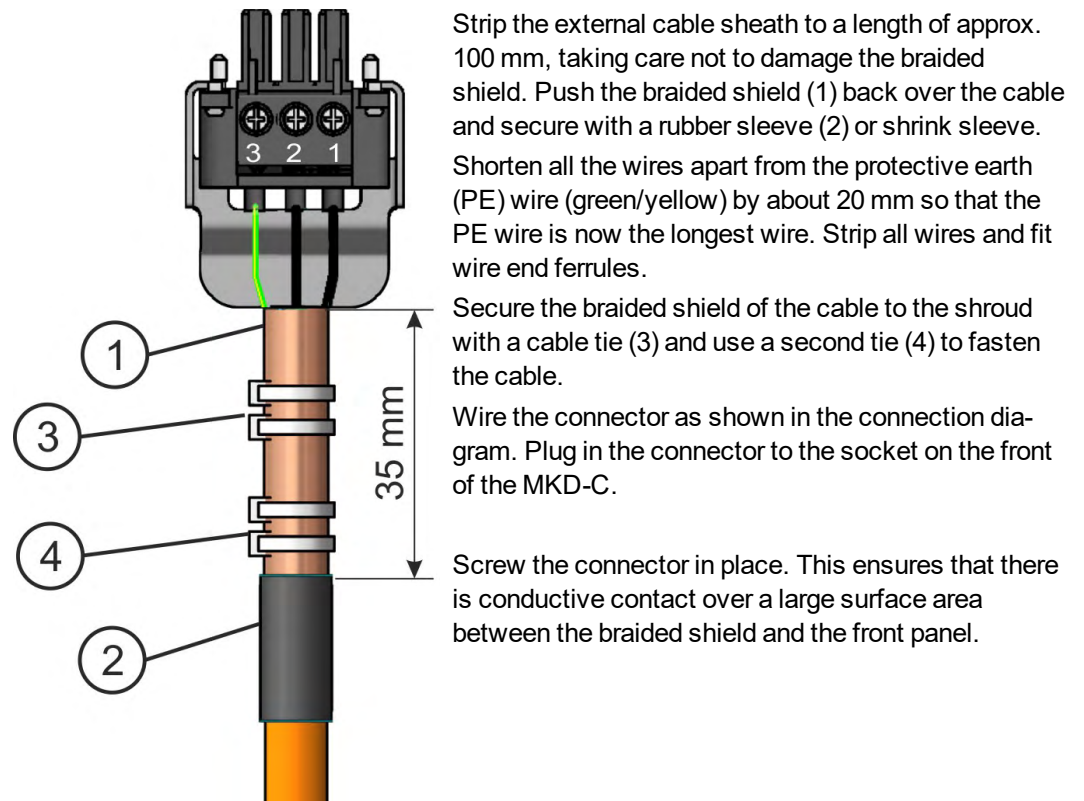

9.4.2.3 Local fieldbus connectors X21A, X21B

The shield of local fieldbus cables is connected via the connector to the housing.

9.4.2.4 Example for system earthing

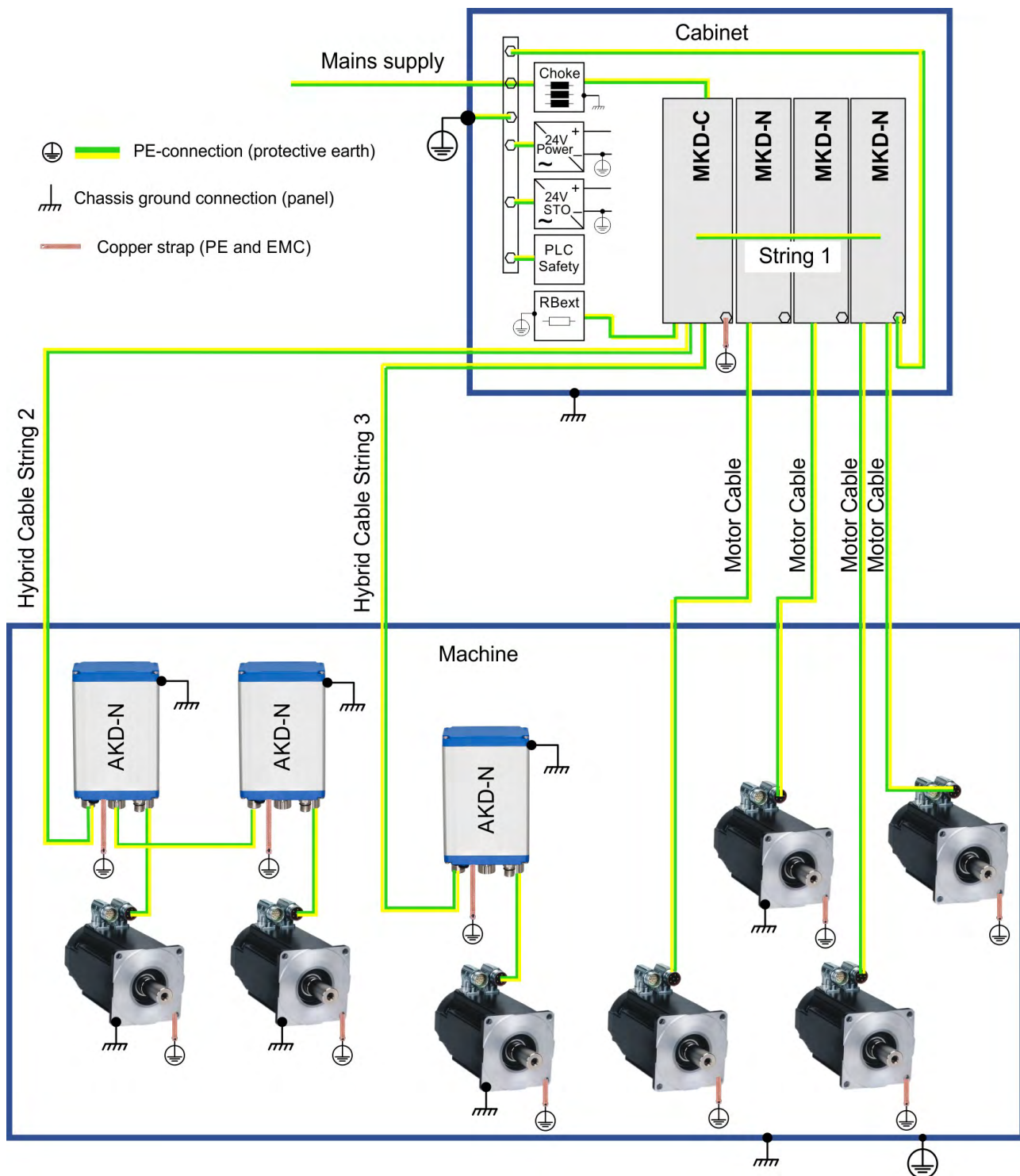

9.5 System topology of an MKD drive system

9.5.1 System limits

Length String 2/3	Maximum 100 m total cable length per string.
Number of MKD-C	Limited by fieldbus protocol.
Number of MKD-N axes	Maximum 14 axes for string 1, total maximum 28 axes if string 1 and 2 are combined (observe total power and current restrictions).
Number of AKD-N	Maximum 14 per string, total maximum 28 on strings 2 and 3, (observe total power and current restrictions).
Output current	Use coincidence factor of the axes for distribution and system power optimization. String 1: 43 A, String 2: 16 A, String 3: 16 A
Total power	At 565 V to 680 V limited to 30 kW.
String 2/3 power	At 565 V to 680 V limited to 10 kW for each string.
String standby power	At 55 V limited to 180 W for each string.
Motor Brake power	You can control up to 3 motor brakes per string. Available power for brakes is 76 W per string (= 3.2 A @ 24 VDC).
Service Interface X18	Ethernet TCP/IP, 100 Mbit/s, max. cable distance 100 m

9.5.2 Topology example with two external strings

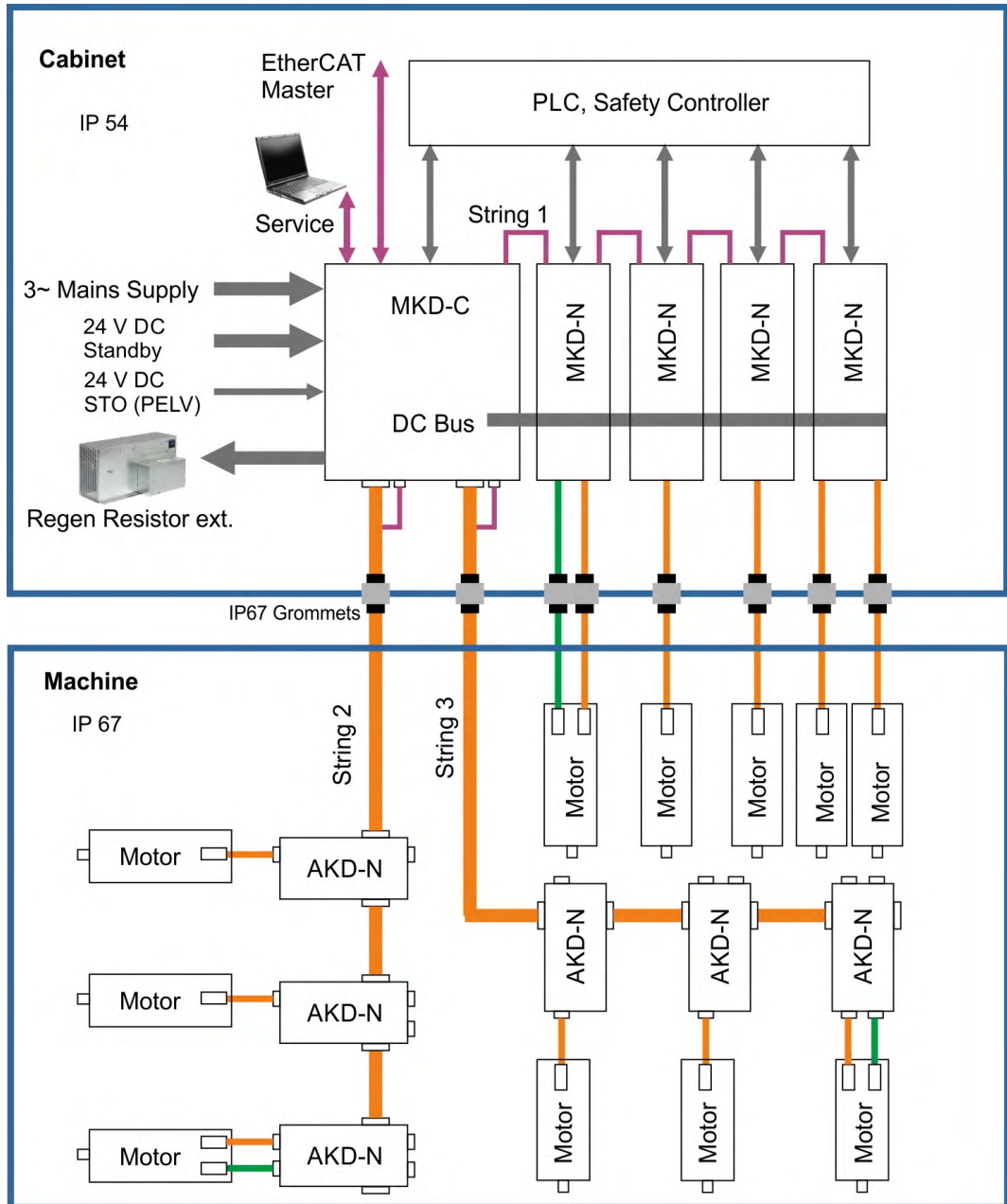

9.5.3 Topology example with one external string migrated to cabinet

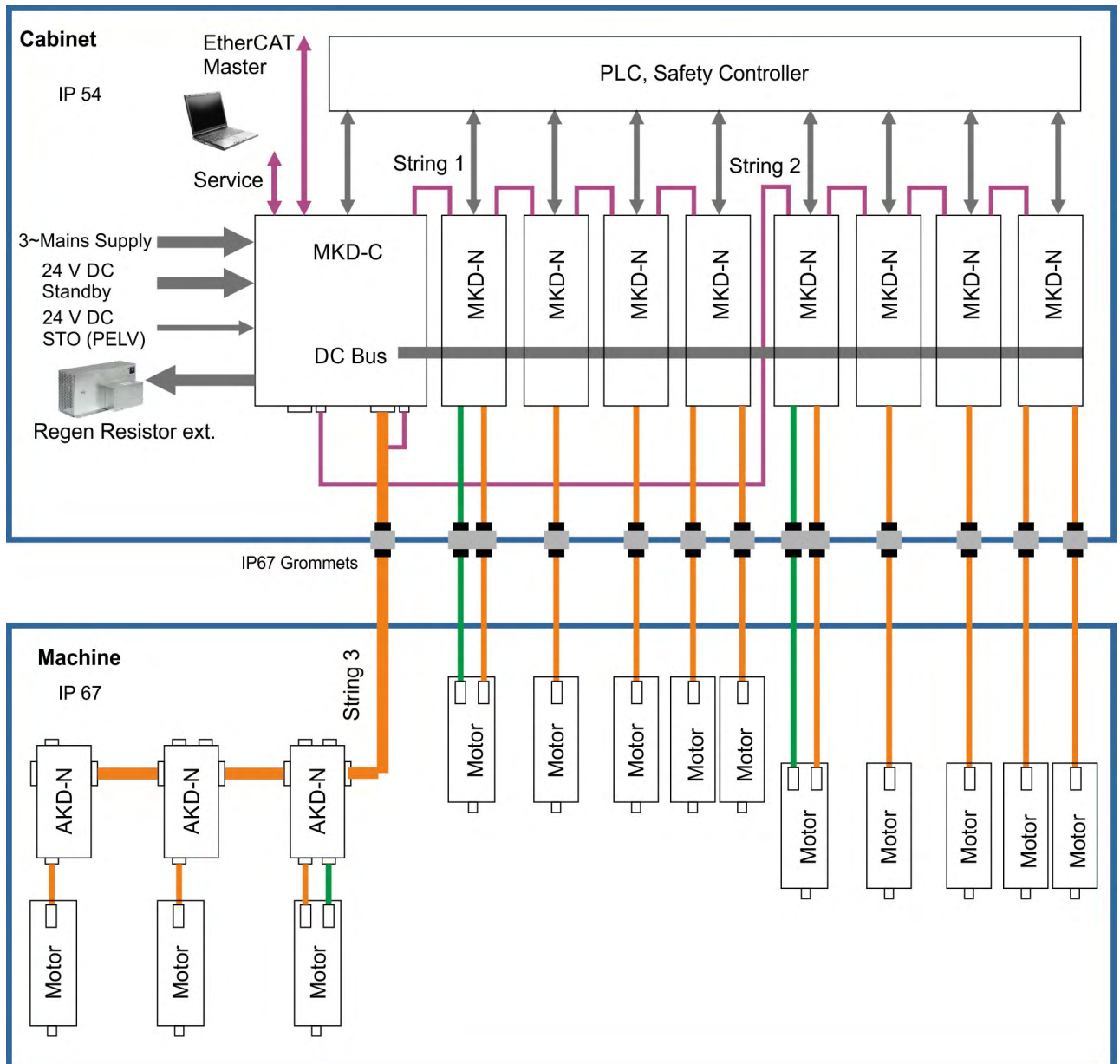

9.6 Connection Overview

9.6.1 Connector Position MKD-C

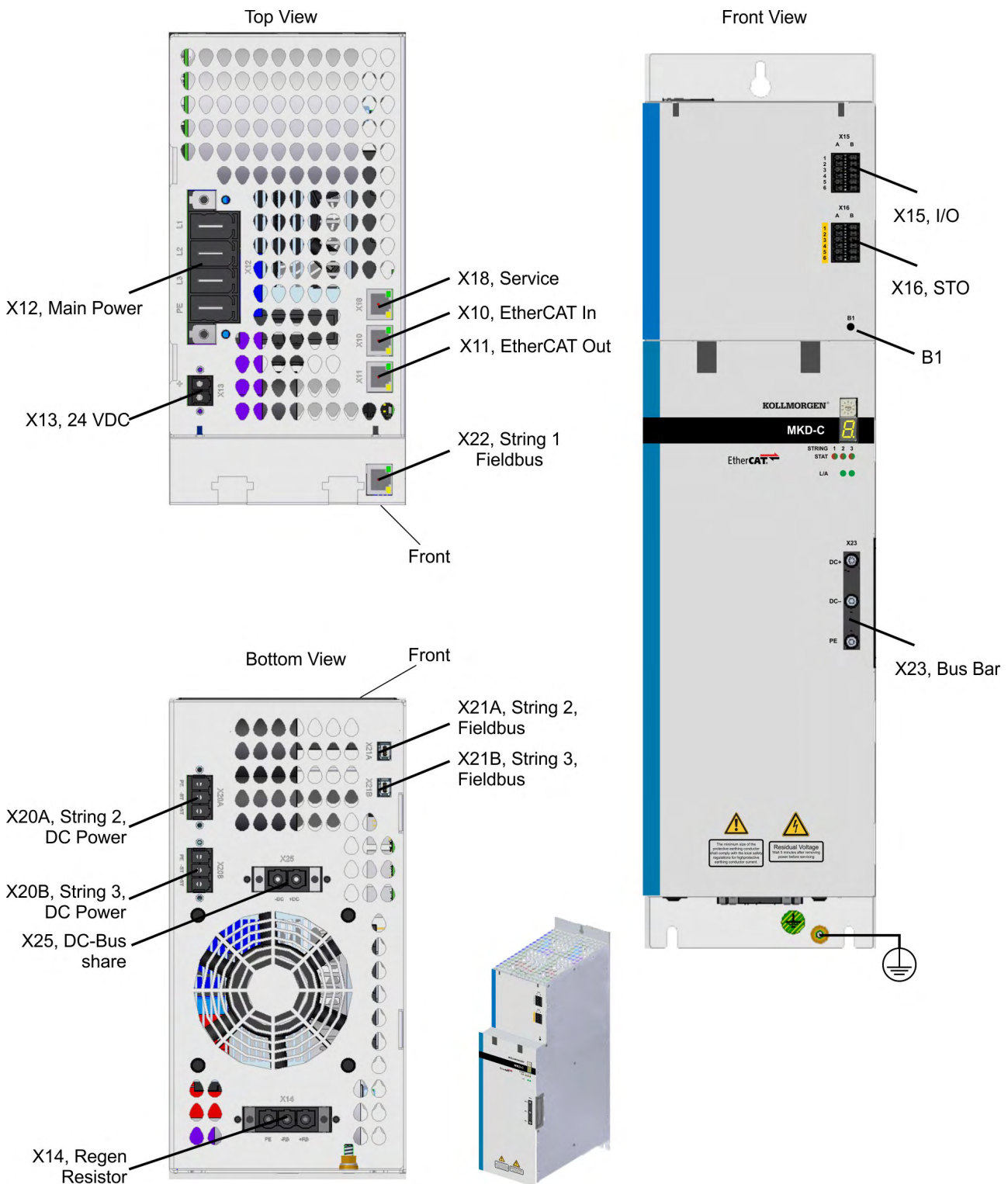

9.6.2 Connector Position MKD-N (6A, 12A)

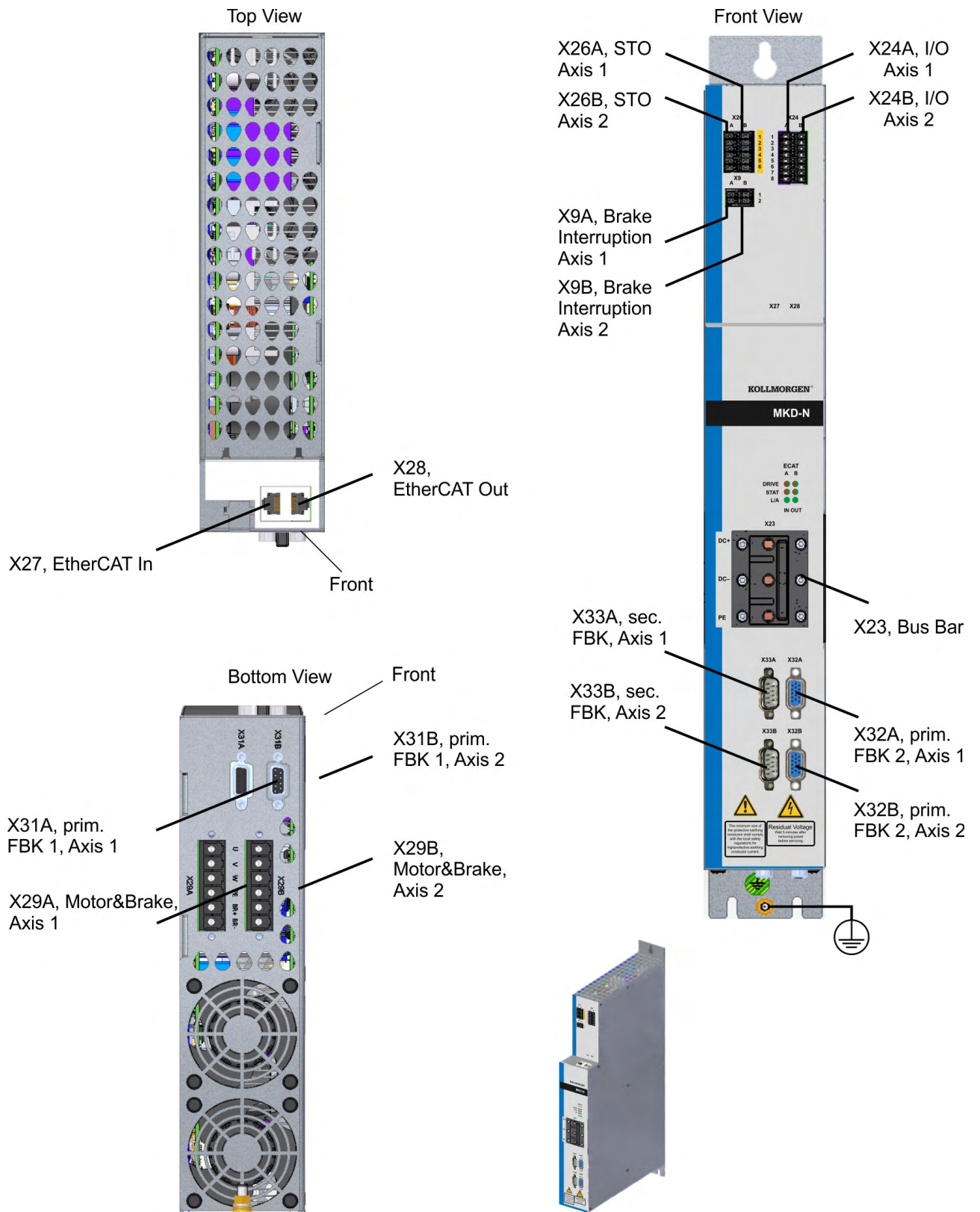

9.6.3 Connector Position MKD-N (24A)

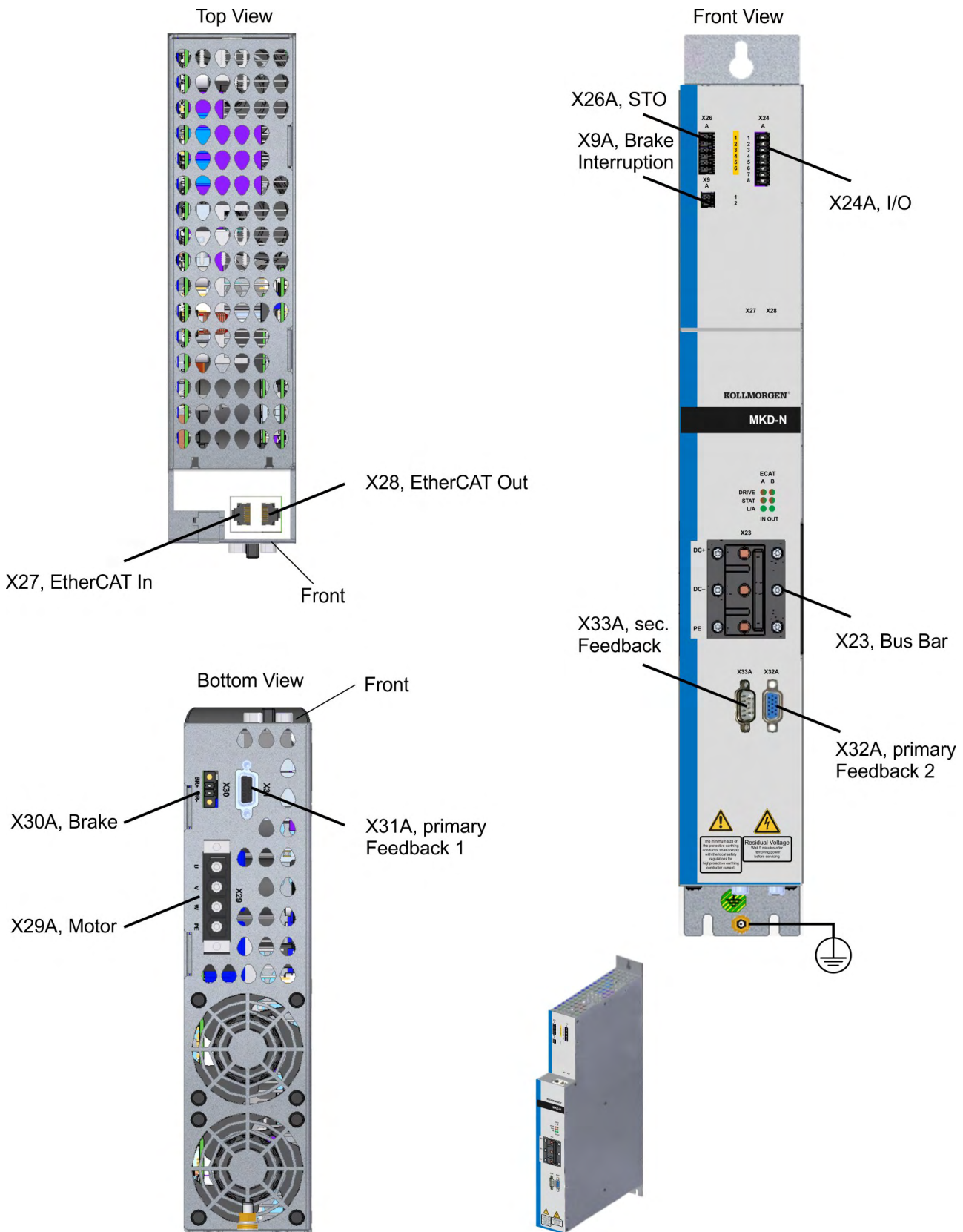

9.6.4 Connector Position MKD-N (48A)

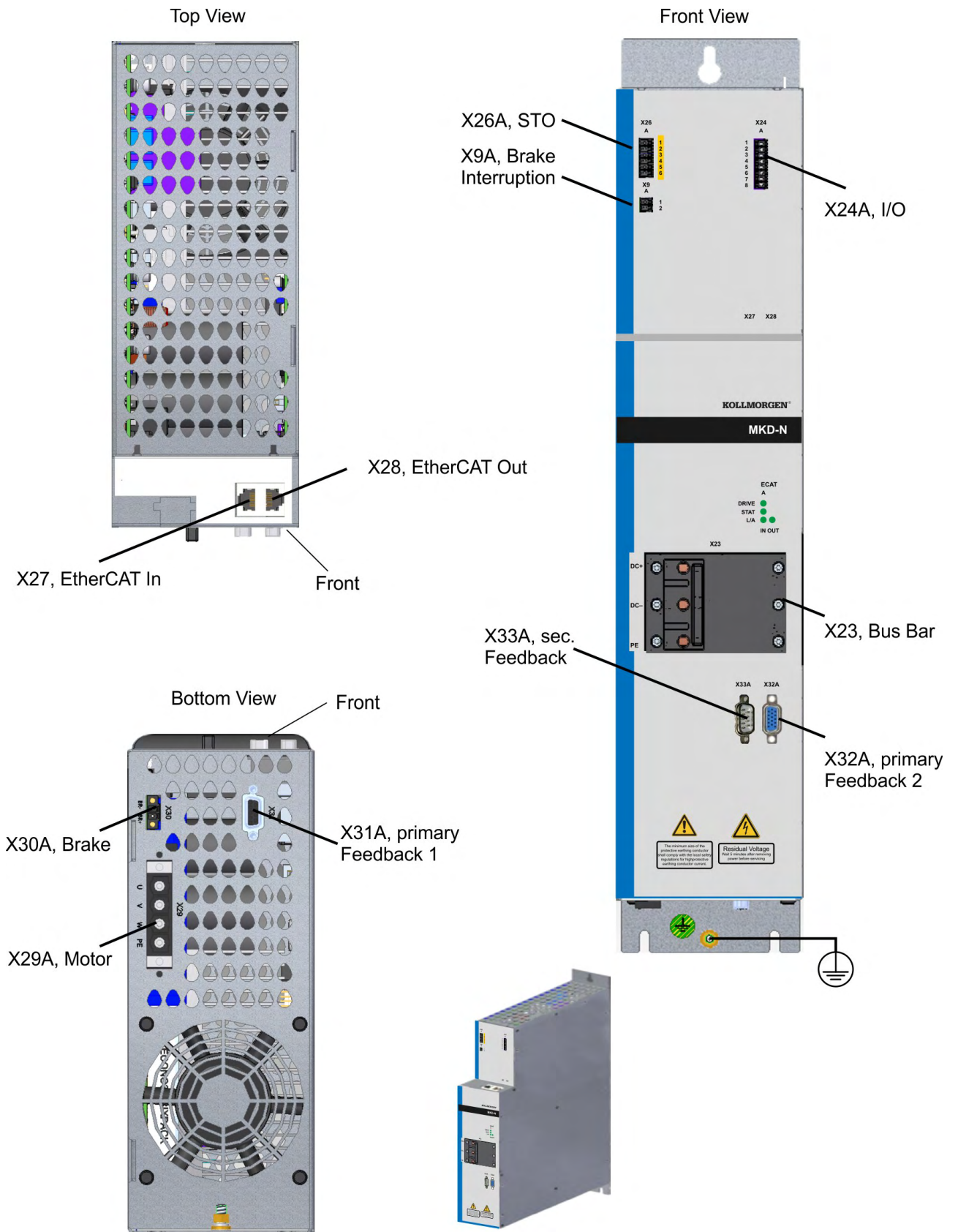

9.6.5 Connection diagrams

9.6.5.1 MKD-C

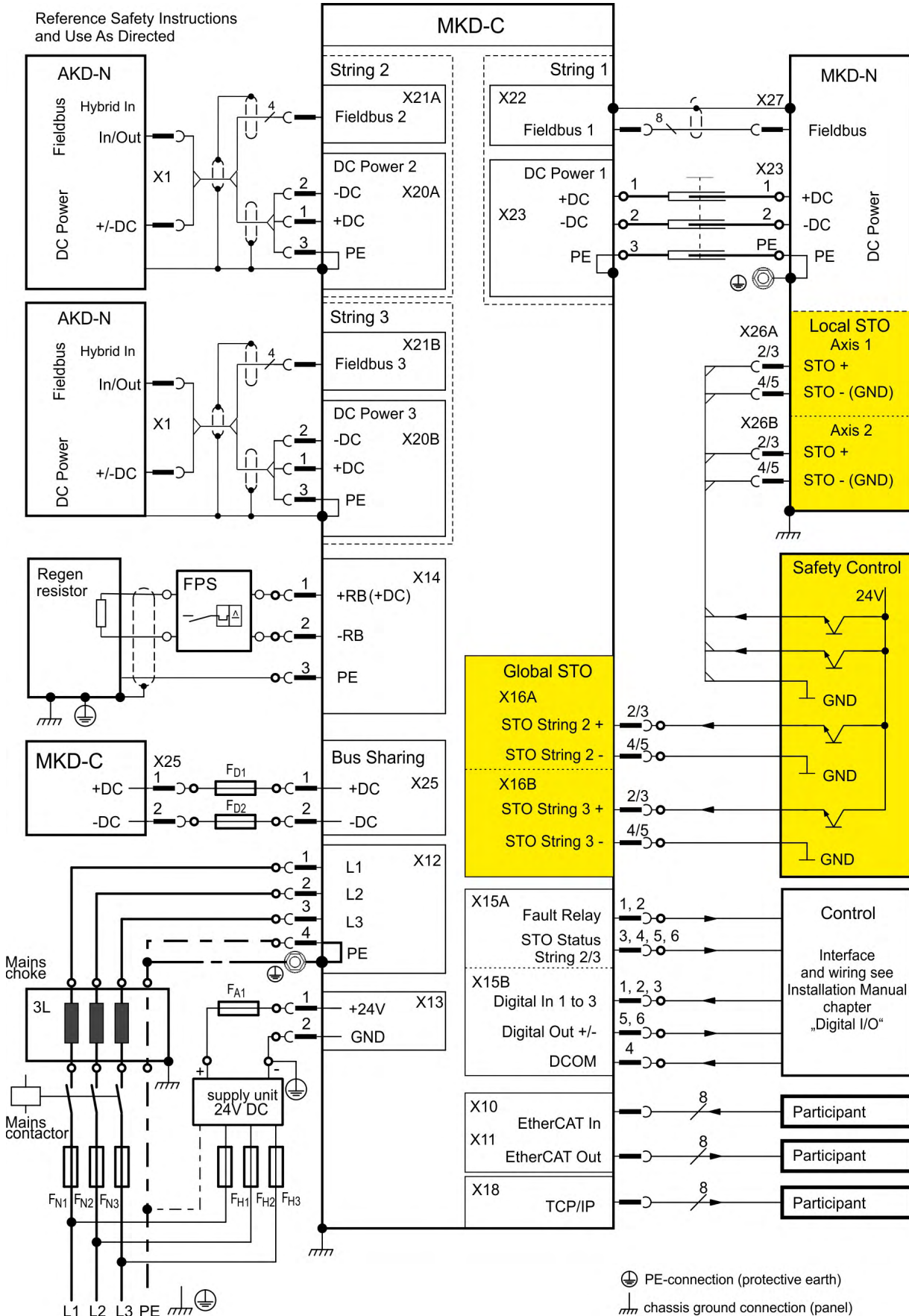

9.6.5.2 MKD-N (6A, 12A)

Reference Safety Instructions and Use as Directed

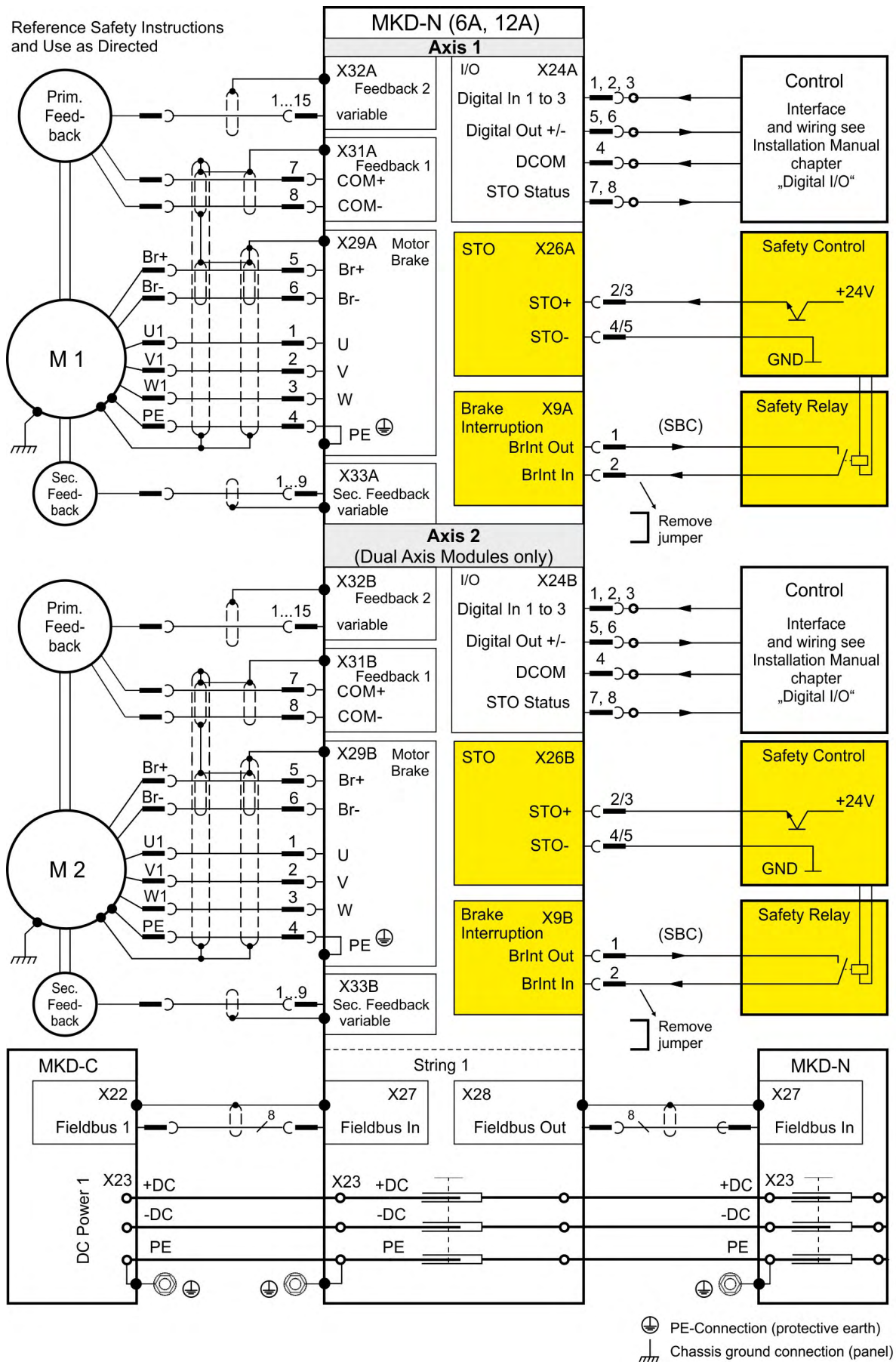

9.6.5.3 MKD-N (24A, 48A)

Reference Safety Instructions and Use as Directed

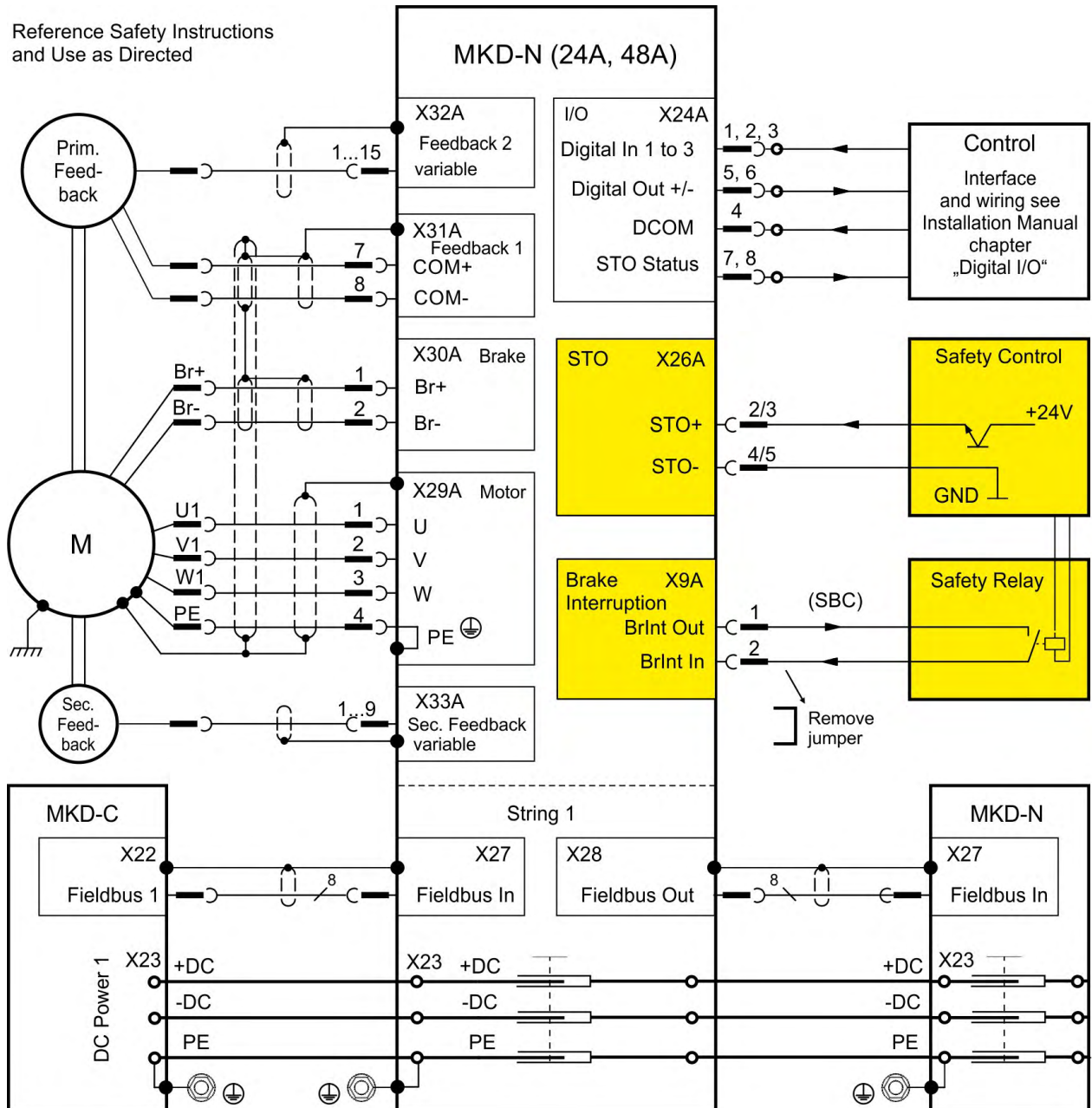

PE-Connection (protective earth)
Chassis ground connection (panel)

9.6.6 Connector pin assignments

NOTE

- Connector and mating connector data (→ # 39).
- Recommended cable cross sections and wiring details (→ # 41).
- Cable length restrictions (→ # 43).

9.6.6.1 X9A, X9B: MKD-N, Brake interruption

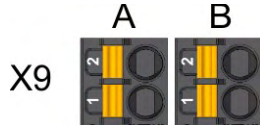

- MKD-N, front
- 2 pin, pitch 3.5 mm
- X9A for Axis 1, X9B for Axis 2 if applicable
- Wiring example Brake Interruption (→ # 116)

Pin	Signal	Description
1	Brlnt Out	Brake interruption +
2	Brlnt In	Brake Interruption -

NOTICE

This functionality is not approved nor certified. Do not use this functionality in applications. Use cable with minimum 0.5 mm² cross section to jumper the contact pins 1 and 2.

9.6.6.2 X10, X11: MKD-C, EtherCAT Fieldbus In/Out



- MKD-C, top
- RJ45 with built-in green and yellow LEDs
- X10 IN port, X11 OUT port
- Interface Details: (→ # 103)

Pin	Signal	Pin	Signal
1	Transmit +	5	n.c.
2	Transmit -	6	Receive-
3	Receive+	7	n.c.
4	n.c.	8	n.c.

9.6.6.3 X12: MKD-C, Mains Supply

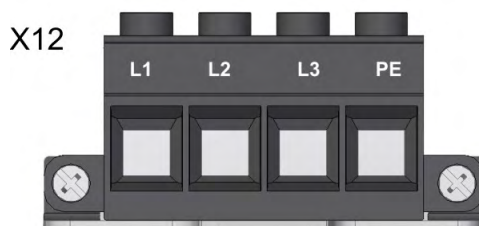

- MKD-C, top
- 4 pin, pitch 7.62 mm
- With shield plate
- Wiring example power supply (→ # 81)

Pin	Signal	Description
1	L1	3~ mains supply L1, 1~ supply L, DC supply +
2	L2	3~ mains supply L2
3	L3	3~ mains supply L3, 1~ supply N, DC supply -
4	PE	Protective earth

9.6.6.4 X13: MKD-C, 24V DC Logic Supply

X13

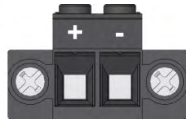

- MKD-C, top
- 2 pin, pitch 5.08 mm
- optional T version
- Wiring example 24V supply (→ # 82)

Pin	Signal	Description
1	+ 24 V	+24 VDC supply voltage, PELV
2	GND	Ground for 24 VDC supply voltage, PELV

9.6.6.5 X14: MKD-C, External regen resistor

X14

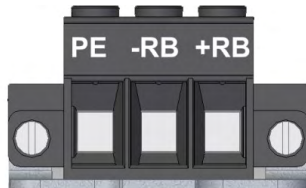

- MKD-C, bottom
- 3 pin, pitch 7.62 mm
- optional T version
- Wiring example external regen resistor (→ # 88)

Pin	Signal	Description
1	+ RB	External regen resistor +
2	- RB	External regen resistor -
3	PE	Protective earth

9.6.6.6 X15A, X15B: MKD-C, I/O

X15

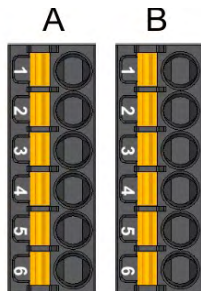

- MKD-C, front
- 2 x 6 pins, pitch 3.5 mm
- Wiring examples:
 - Digital input (→ # 99)
 - Digital Output (→ # 101)

X15A Pin	Signal	Description
1	Relay Out +	Relay contact, normally open, 24 VDC, 1A
2	Relay Out -	Relay contact, normally open, 24 VDC, 1A
3	STO Status String 2+	Global STO Status + for String 2
4	STO Status String 2-	Global STO Status - for String 2
5	STO Status String 3+	Global STO Status + for String 3
6	STO Status String 3-	Global STO Status - for String 3

X15B Pin	Signal	Description
1	Digital-In 1	Slow, isolated, sink, type EN 61131-2 type 1
2	Digital-In 2	Slow, isolated, sink, type EN 61131-2 type 1
3	Digital-In 3	Slow, isolated, sink, type EN 61131-2 type 1
4	DCOM	Ground for digital I/O
5	Digital-Out+	Slow, isolated, sink, type EN 61131-2 type 1
6	Digital-Out-	Slow, isolated, sink, type EN 61131-2 type 1

9.6.6.7 X16A, X16B: MKD-C, Global STO String 2 and 3

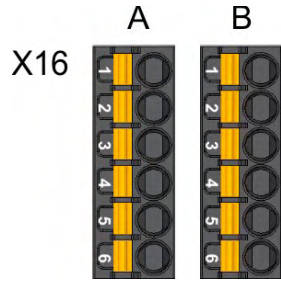

- MKD-C, front
- 2 x 6 pins, pitch 3.5 mm
- X16A for String 2, X16B for String 3
- Wiring examples: Global STO (→ # 109)

X16A Pin	Signal	Description
1	+ 24 V	24 V output voltage (unused)
2	STO String 2 +	Global STO Enable String 2 +
3	STO String 2 +	Global STO Enable String 2 +
4	STO String 2 -	Global STO Enable String 2 -
5	STO String 2 -	Global STO Enable String 2 -
6	GND	Ground

X16B Pin	Signal	Description
1	+ 24 V	24 V output voltage (unused)
2	STO String 3 +	Global STO Enable String 3 +
3	STO String 3 +	Global STO Enable String 3 +
4	STO String 3 -	Global STO Enable String 3 -
5	STO String 3 -	Global STO Enable String 3 -
6	GND	Ground

9.6.6.8 X18: MKD-C, Service



- MKD-C, top
- RJ45 with built-in green and yellow LEDs
- 100/10 Mbit Ethernet TCP/IP
- Supports auto-IP, DHCP and fixed IP addressing
- Supports point-to-point (i.e. Auto-IP) and connection via network switches
- Supports automatic discovery in WorkBench if in the same sub-net.
- Interface Details: (→ # 104)

Pin	Signal	Description
1	Tx +	Transmit +
2	Tx -	Transmit -
3	Rx +	Receive +
6	Rx -	Receive -

9.6.6.9 X20A, X20B: MKD-C, String 2/3 DC Power

X20A
X20B



- MKD-C, bottom
- 3 pin, pitch 5.08 mm
- X20A for String 2, X20B for String 3
- String Wiring: (→ # 87)

Pin	Signal	Description
1	+ST	String DC Power +
2	-ST	String DC Power -
3	PE	Protective earth

9.6.6.10 X21A, X21B: MKD-C, String 2/3 Communication

X21A
X21B



- MKD-C, bottom
- Mini I/O
- X21A for String 2, X21B for String 3
- String Wiring: (→ # 87)

Pin	Signal	Description
1	Rx +	Receive +
2	Rx -	Receive -
3	Tx +	Transmit +
6	Tx -	Transmit -

9.6.6.11 X22: MKD-C, String 1 Communication

X22



- MKD-C, front
- RJ45 with built-in green and yellow LEDs
- String Wiring: (→ # 85)

Pin	Signal	Description
1	Tx+	Transmit +
2	Tx -	Transmit -
3	Rx +	Receive +
6	Rx -	Receive -

9.6.6.12 X23: MKD-C, MKD-N, String 1 DC Power

X23

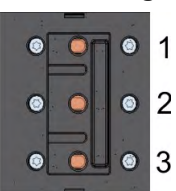

- MKD-C, MKD-N, front
- 3 slide contacts with screws
- Connects DC-Bus link between modules
- Handling: (→ # 83)

Pin	Signal	Description
1	+ DC	DC bus link +
2	- DC	DC bus link -
3	PE	Protective earth

9.6.6.13 X24A, X24B: MKD-N, I/O

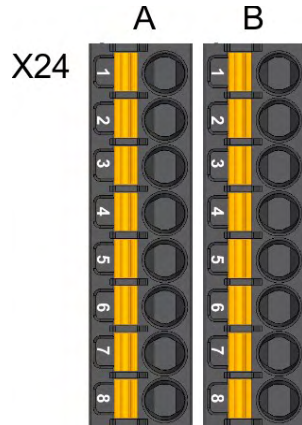

- MKD-N, front
- 8 pins, pitch 3.5 mm
- X24A for axis 1, X24B for axis 2 if applicable
- Wiring examples:
 - Digital input (→ # 99)
 - Digital Output (→ # 101)

Pin	Signal	Description
1	Digital-In 1	Fast, isolated, sink, type EN 61131-2 type 1
2	Digital-In 2	Fast, isolated, sink, type EN 61131-2 type 1
3	Digital-In 3	Slow, isolated, sink, type EN 61131-2 type 1
4	DCOM	Ground for digital I/O
5	Digital-Out+	Slow, isolated, sink, type EN 61131-2 type 1
6	Digital-Out-	Slow, isolated, sink, type EN 61131-2 type 1
7	STO Status Out+	Local STO Status +
8	STO Status Out-	Local STO Status -

9.6.6.14 X25: MKD-C, DC Bus sharing

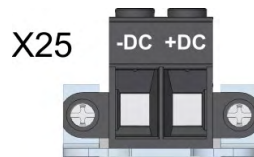

- MKD-C, bottom
- 2 pin, pitch 7.62 mm
- With shield plate
- Wiring example DC-Bus (→ # 83)

Pin	Signal	Description
1	+ DC	DC-Bus link +
2	- DC	DC-Bus link -

9.6.6.15 X26A, X26B: MKD-N, Local STO

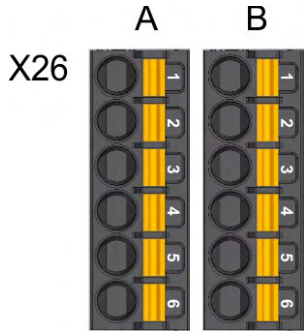

- MKD-N, front
- 2 x 6 pins, pitch 3.5 mm
- X26A for axis 1, X26B for axis 2 if applicable
- Wiring examples: Local STO (→ # 113)

Pin	Signal	Description
1	+ 24 V	24 V output voltage (unused)
2	STO +	Local STO Enable +
3	STO +	Local STO Enable +
4	STO -	Local STO Enable -
5	STO -	Local STO Enable -
6	GND	Ground

9.6.6.16 X27, X28: MKD-N, String Communication

X27 X28



- MKD-N, front
- RJ45 with built-in green and yellow LEDs
- X27 IN port, X28 OUT port
- Node ID to be set by WorkBench
- Interface Details: (→ # 85)

Pin	Signal	Description
1	Tx+	Transmit +
2	Tx -	Transmit -
3	Rx +	Receive +
6	Rx -	Receive -

9.6.6.17 X29A, X29B: MKD-N 6A or 12A, Motor Power, Brake

X29A
X29B

- MKD-N, bottom
- 6 pin, pitch 7.62 mm
- X29A for Axis 1, X29B for Axis 2 if applicable
- Motor power, Motor brake
- With shield plate
- Wiring example motor power/brake (→ # 89)

Pin	Signal	Description
1	U	Motor phase U
2	V	Motor phase V
3	W	Motor phase W
4	PE	Protective earth
5	BR+	Motor holding brake +
6	BR-	Motor holding brake -

9.6.6.18 X29A: MKD-N 24A or 48A, Motor Power

X29A

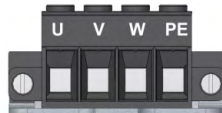

- MKD-N, bottom
- 4 pin, pitch 7.62 mm
- Motor power, Motor brake
- With shield plate
- Wiring example motor power (→ # 89)

Pin	Signal	Description
1	U	Motor phase U
2	V	Motor phase V
3	W	Motor phase W
4	PE	Protective earth

9.6.6.19 X30A : MKD-N 24A or 48A, Motor Brake

X30A

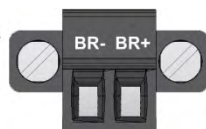

- MKD-N, bottom
- 2 pin, pitch 3.81 mm
- required for SIL3 brake control
- Wiring example motor brake (→ # 89)

Pin	Signal	Description
1	BR+	Motor holding brake +
2	BR-	Motor holding brake -

9.6.6.20 X31A, X31B: MKD-N, commutation Feedback 1

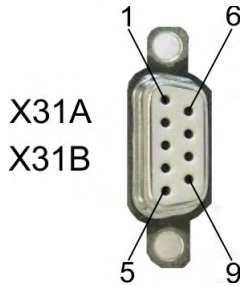

- MKD-N, bottom
- Sub-D 9 pin, female
- Mating connector male
- Input for two wire primary feedback
- X31A for Axis 1, X31B for Axis 2 if applicable
- Wiring examples single cable primary Feedback (→ # 91)

Pin	Signal	Description
1 to 6	-	not connected
7	COM+	SFD3 + or HIPERFACE DSL +
8	COM-	SFD3 - or HIPERFACE DSL -
9	-	not connected

9.6.6.21 X32A, X32B: MKD-N, commutation Feedback 2

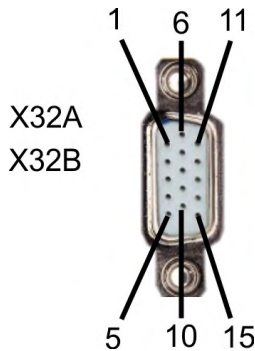

- MKD-N, front
- Sub-D high density 15 pin, female
- Mating connector male
- Input for conventional primary feedback
- X32A for Axis 1, X32B for Axis 2 if applicable
- Wiring examples dual cable primary Feedback (→ # 94)

Pin	SFD	BiSS B	BiSS C	EnDAT 2.1	EnDAT 2.2	Sine/Cos +Hall	Incr. Enc. +Hall
1	-	-	-	-	-	Hall U	Hall U
2	-	CLK+	CLK+	CLK+	CLK+	Hall V	Hall V
3	-	CLK-	CLK-	CLK-	CLK-	Hall W	Hall W
4	SEN+	SEN+	SEN+	SEN+	SEN+	SEN+	SEN+
5	SEN-	SEN-	SEN-	SEN-	SEN-	SEN-	SEN-
6	COM+	DAT+	DAT+	DAT+	DAT+	Zero+	Zero+
7	COM-	DAT-	DAT-	DAT-	DAT-	Zero-	Zero-
8	-	Thermal control (+)					
9	-	Thermal control (-)					
10	+5V	+5V	+5V	+5V	+5V	+5V	+5V
11	0V	0V	0V	0V	0V	0V	0V
12	-	A+	-	A+	-	A+	A+
13	-	A-	-	A-	-	A-	A-
14	-	B+	-	B+	-	B+	B+
15	-	B-	-	B-	-	B-	B-

CLK = CLOCK, DAT = DATA, SEN = SENSE

9.6.6.22 X33A, X33B: MKD-N, secondary Feedback

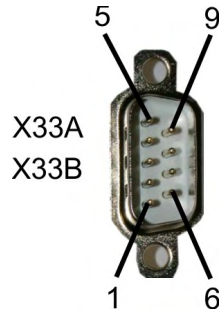

- MKD-N, front
- Sub-D 9 pin, male
- Mating connector female
- Input for secondary feedback
- X33A for Axis 1, X33B for Axis 2 if applicable
- Wiring examples secondary Feedback (→ # 95)

Pin	Sine / Cos	Incr. Enc.
1	A+	A+
2	A-	A-
3	0 V	0 V
4	B+	B+
5	B-	B-
6	Shield	Shield
7	Zero+	Zero+
8	Zero-	Zero-
9	+5 V	+5 V

9.7 Electrical Supply Connection

9.7.1 Connection to various mains supply networks

This page illustrates all the possible connection variations for different electrical supply networks. Rated supply voltage (TT network) for MKD-C is 400/480 VAC.

NOTICE An isolating transformer is required for non TT networks or other voltage ratings.

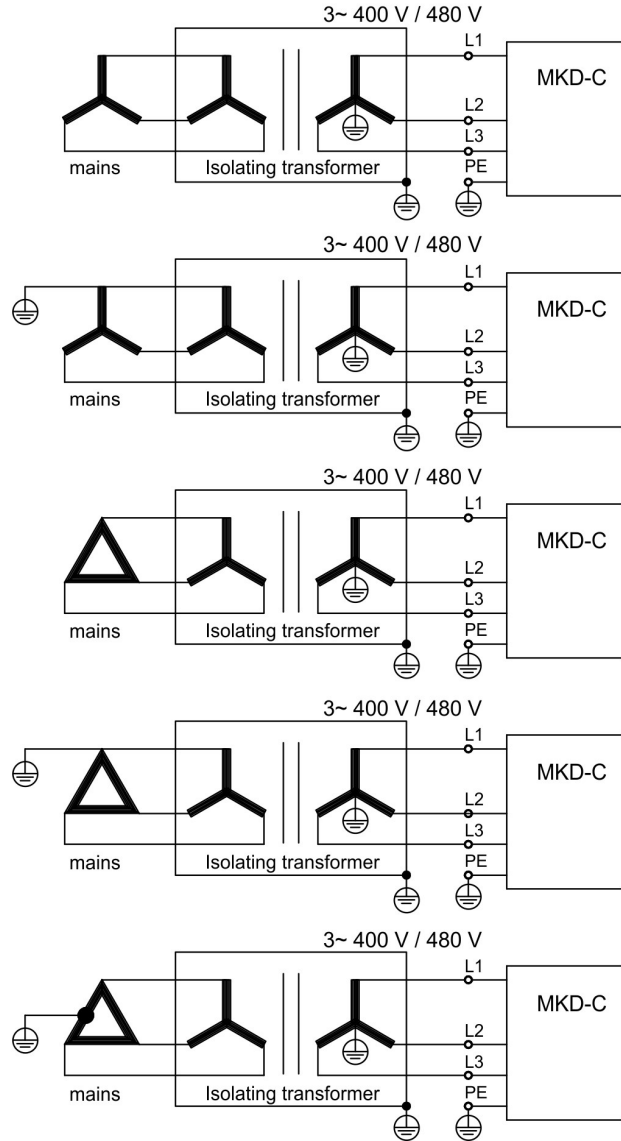
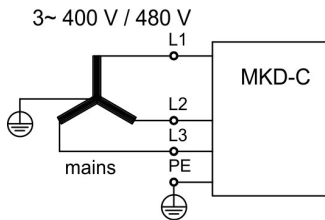

9.7.2 Mains supply connection (X12)

9.7.2.1 Three phase connection

- Directly to 3-phase supply network (→ # 80), 400/480 VAC, 50/60 Hz
- Fusing (such as fusible cut-outs, FN1/2/3) to be provided by the user (→ # 37).
- Mains supply: 3~

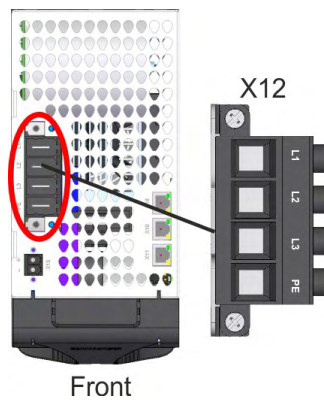
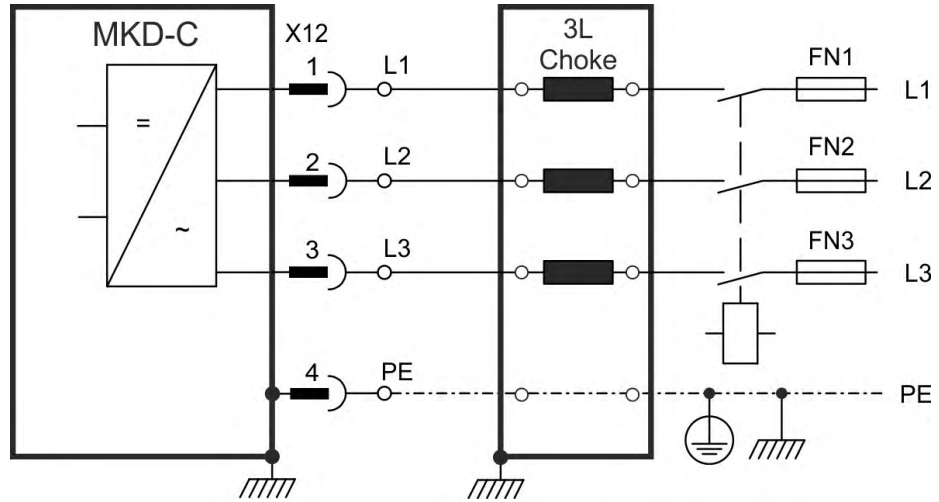

Pin	Signal	Description
1	L1	Line 1
2	L2	Line 2
3	L3	Line 3
4	PE	Protective Earth

9.7.3 Logic supply voltage 24 VDC (X13)

The following diagram describes external 24 VDC / max. 40 A power supply, electrically isolated, for example, via an isolating transformer. The required current rating depends on the use of motor brake and number of connected MKD-N drives.

The 24 VDC voltage is internally split into a control supply to power the MKD-C electronics and a supply voltage to power the connected MKD-N drives in case of switched off AC mains power.

NOTE Standby power is limited to 750 W at 24 V for both strings. This power must supply all drive modules and the remaining power can be used for motor holding brakes.

Fusing (such as fusible cut-outs, FA1) to be provided by the user, "Fusing" (→ # 37).

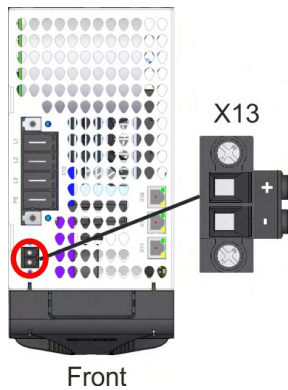
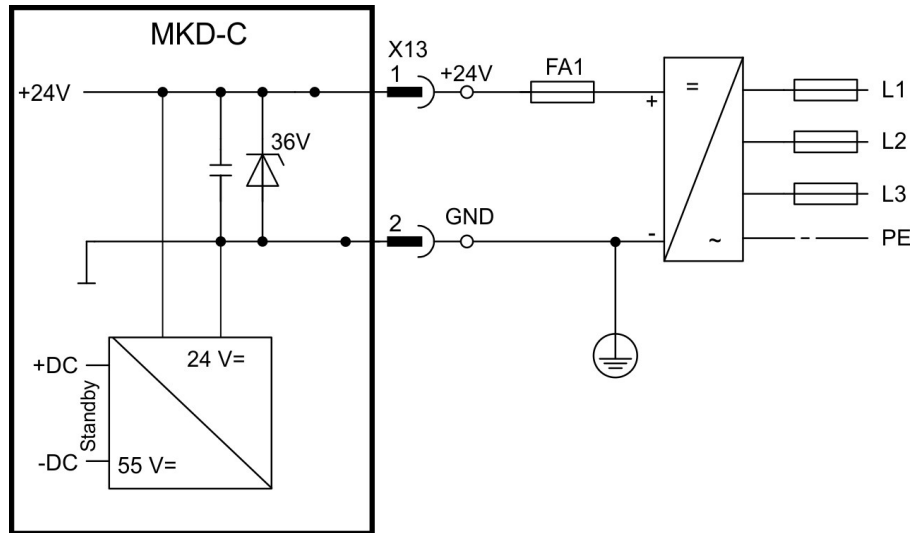

Pin	Signal	Description
1	+24	+24 VDC Auxiliary voltage
2	GND	24V Supply GND

9.8 DC Bus link (X20, X23, X25)

9.8.1 DC Bus bar MKD-C to MKD-N, MKD-N to MKD-N

The DC bus connection between MKD modules is realized by a slider X23.

The sliders are secured with one Torx (TX20 head) screw per pin.

NOTICE

- All screws (on both modules) have to be tightened before switching on voltage.
- Release all screws before moving the slider.
- On the last (right end) MKD-N Module in the system add the plastic cover and tighten the screws in order to ensure from accidental touch of energized parts.

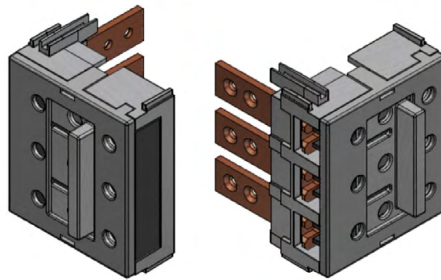

Pin	Signal	Description
1	+DC	DC Bus link positive
2	-DC	DC Bus link negative
3	PE	Protective Earth

9.8.2 DC Bus Strings MKD-C to AKD-N

Up to 28 AKD-N decentralized drives can be connected to the MKD-C via hybrid string cables on X20/X21 (→ # 84).

9.8.3 DC Bus sharing MKD-C to MKD-C

NOTICE

DC Bus sharing functionality is pending. Do not use this functionality until further notice.

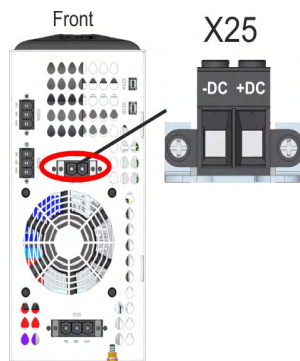

Pin	Signal	Description
1	+DC	DC Bus link positive
2	-DC	DC Bus link negative

9.8.4 Drive String Connection

MKD-C support three strings to connect up to 42 drive axes (→ # 61). The strings are built of a DC-Bus and an internal fieldbus connection.

The DC-Bus is powered with 565 VDC to 680 VDC depending on the mains voltage in standard operation.

If the 3 phase mains voltage is not available, a 55 VDC stand-by power is available from the 24 VDC supply for emergency ramp down or brake situations.

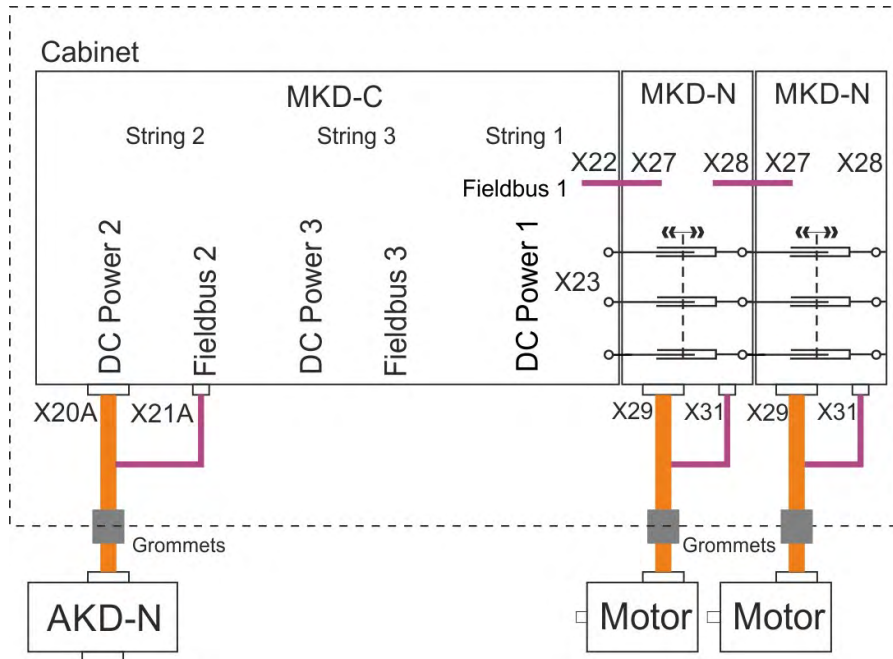

Cable which exit the cabinet, should be threaded through grommets.

To ensure protection class IP67, Kollmorgen recommends cable entry system KDL/S combined with cable entry grommet KDT/S manufactured by :

Murrplastik Systemtechnik GmbH
 Fabrikstraße 10
 71570 Oppenweiler, Germany
 Phone: +49 (0)7191 482-0
 Website: www.murrplastik.de
 E-Mail: info@murrplastik.de

9.8.4.1 String 1 (central)

String 1 can be used for connecting central MKD-N drive modules with up to 14 axes.

MKD-N drives modules are connected via sliding terminals (X23, DC Power) and a short fieldbus cable (X22-X27, X28-X27, Fieldbus) to string 1. The string is limited to 30 kW rated power.

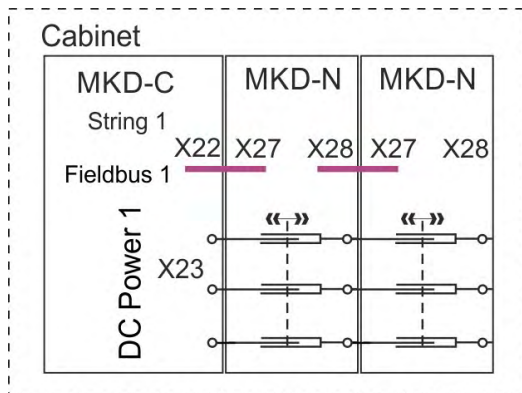

DC power (X23)

The DC power lines supply DC power for up to 14 MKD-N drives in string 1. Connection for the DC power must be done by a sliding terminals (X23).

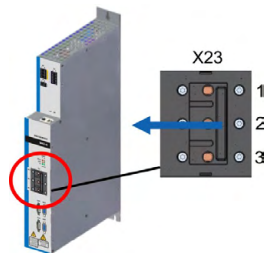

Pin	Signal	Description
1	+ DC	String 1 DC power positive
2	- DC	String 1 DC power negative
3	PE	Protective earth

Local Fieldbus (X22, X27, X28)

Local fieldbus connector enables the MKD-C (X22) to communicate with all connected MKD-N via a four line bus medium. Front and RJ45 LED signals (→ # 45).

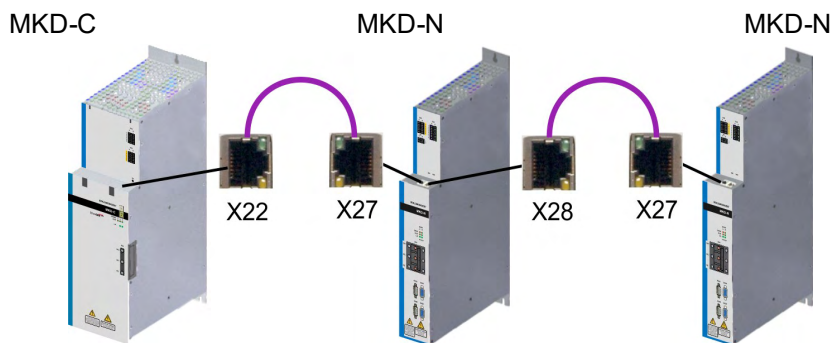

X22 to X27 or X28 to X27 are connected via the short EtherCAT Module cable (→ # 132).

Pin	Signal	Description
1	Tx+	Transmit +
2	Tx -	Transmit -
3	Rx +	Receive +
6	Rx -	Receive -

NOTICE

These port may not be directly connected to standard EtherCAT or Ethernet TCP/IP nodes.

9.8.4.2 Strings 1 and 2 (central)

The number of central drive axes can be duplicated by using string 2 as an internal string.

- MKD-N drive modules in string 1 are connected via slider terminals (X23, DC Power) and a short fieldbus cable (X22-X27, X28-X27, Fieldbus) to string 1.
- MKD-N drive modules in string 2 are connected via sliding terminals (X23, DC Power) and a fieldbus adapter cable (X21A-X28, Fieldbus). The combined strings 1 and 2 are limited to 30 kW rated power.

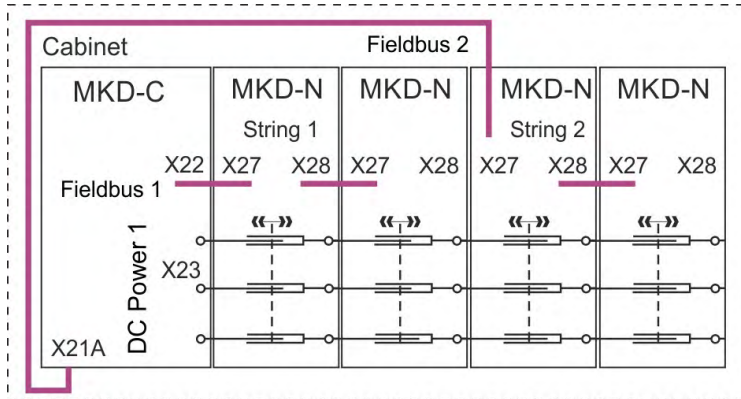

DC power (X23)

The DC power lines supply DC power for up to 28 MKD-N drives in string 1 and string 2. Connection for the DC power must be done by a sliding terminals (X23).

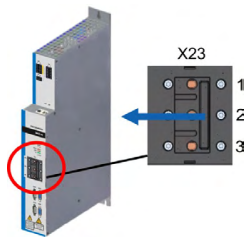

Pin	Signal	Description
1	+ DC	String 1 DC power positive
2	- DC	String 1 DC power negative
3	PE	Protective earth

Local Fieldbus (X21A, X27)

String 2 fieldbus connector X21A enables the MKD-C to communicate with all connected MKD-N via a four line bus medium. This interface is connected to X27 via the Communication Adapter String 2 (→ # 132). Front and RJ45 LED signals (→ # 45).



Pin	Signal	Description
1	Rx +	Receive +
2	Rx -	Receive -
3	Tx +	Transmit +
6	Tx -	Transmit -

9.8.4.3 Strings 2 and 3 (decentral)

Strings 2 and 3 can be used for connecting up to 28 decentral AKD-N drives. Refer to the *AKD-N Installation Manual* for technical description of these drives. Every string is limited to 10 kW rated power.

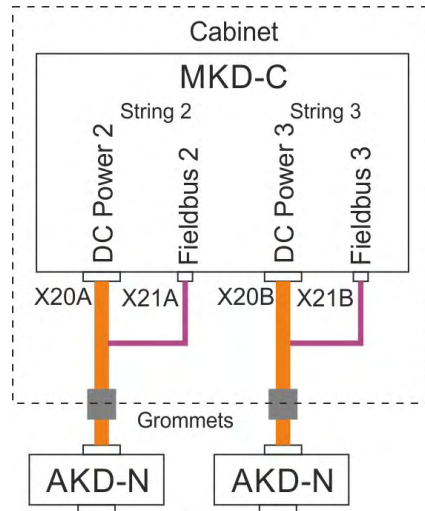

For connecting the first AKD-N to one of the DC strings the Kollmorgen cable type MKC-HYB-z-AKN must be used. This cable is a Y type adapter with one hybrid connector on the AKD-N end and two connectors on the MKD-C end with separate DC power and local fieldbus lines.

The Kollmorgen hybrid cable AKN-HYB-z-AKN must be used to connect more AKD-N.

The Kollmorgen hybrid cables are described in the appendix (→ # 132).

DC power (X20A, X20B)

The DC power lines supply DC power for up to 14 AKD-N drives in one string. Connection for the DC power must be done by a mating connector with strain relief due to EMC reasons. This interface is connected via the Kollmorgen MKC-HYB-z-AKN cable.

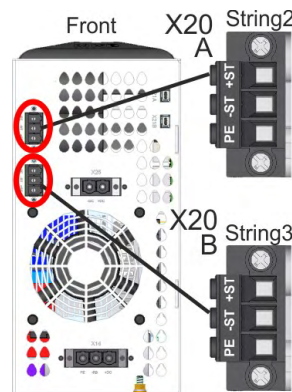

Pin	Signal	Description
1	+ST	String 2/3 DC power positive
2	-ST	String 2/3 DC power negative
3	PE	Protective Earth

X20A supports String 2, X20B supports String 3

Local Fieldbus (X21A, X21B)

Local fieldbus connectors separate for each string enable the MKD-C to communicate with all connected AKD-N via a four line bus medium. This interface is connected via the Kollmorgen MKC-HYB-z-AKN cable. Front LED signals (→ # 45).

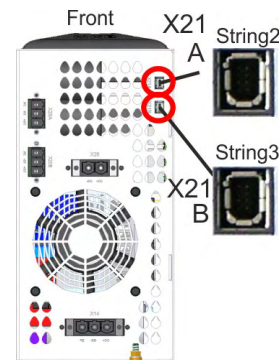

Pin	Signal	Description
1	Rx+	Receive +
2	Rx-	Receive -
3	Tx+	Transmit +
6	Tx-	Transmit -
4,5,7,8	n.c.	not connected

X21A supports String 2, X21B supports String 3

9.8.5 External Regen resistor (X14)

For technical data on the regen circuit (→ # 44).
 Fusing to be provided by the user, (→ # 37).

NOTICE

The regen circuit +RB/-RB is short circuit proof. Observe the prohibition of continuous, operational short circuits to the external regen resistor contacts (→ # 21).

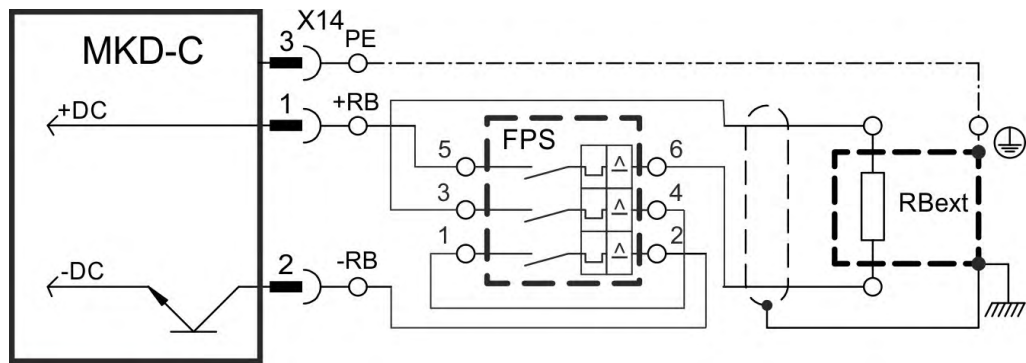

Pin	Signal	Description
1	+RB	External Regen Resistor positive
2	-RB	External Regen Resistor negative
3	PE	Protective Earth

9.9 Motor Connection

Motor Power

Together with the motor supply cable and motor winding, the power output of the drive forms an oscillating circuit. Characteristics such as cable capacity, cable length, motor inductance, and frequency determine the maximum voltage in the system.

The MKD-N drive is able to protect the connected motor from overloading, if the parameters are set correctly and the thermal protection sensor is connected and supervised. With Kollmorgen motors the valid data are automatically set by the internal motor database.

NOTICE

The dynamic voltage rise can lead to a reduction in the motor operating life and, on unsuitable motors, to flash-overs in the motor winding.

- Only install motors with insulation class F (acc. to IEC60085) or above.
- Only install Kollmorgen cables that meet the requirements (→ # 41).

Motor Brakes

A 24 V holding brake in the motor can be controlled directly by the drive. The brake works with sufficient 24 V voltage level only. Check voltage drop, measure the voltage at brake input and check brake function (brake and no brake). Maximum current for the motor brake is 1 A with MKD-N 6 A axes and 1.5 A with MKD-N 12/24/48A axes.

NOTE

The stand-by power supply from MKD-C limits the number of brakes in the system.



CAUTION Cranes, suspended load

Serious injury could result when a suspended load is not properly blocked. Functional safety requires an additional, external mechanical brake, operated by a safety controller. The chapter "Brake interruption contact" describes how to use MKD contacts to realize an SBC function (→ # 116).

- Add a safe mechanical blocking (for instance, an additional brake using the safe brake interruption (→ # 116)).
- Set parameter MOTOR.BRAKEIMM to 1 with vertical axes, to apply the motor holding brake immediately after faults or Hardware Disable.

The brake function must be enabled and configured with parameters using WorkBench, for details refer to the online help.

Motor Feedback

Every closed servo system normally requires at least one feedback device for sending actual values from the motor to the drive. Depending on the type of feedback device used, information will be fed back to the drive using digital or analog means.

MKD-N supports the most common types of feedback devices. SFD3 and HIPERFACE DSL (short: DSL) are feedback systems with a dual line serial interface. These feedback systems are used for single cable connection between motor and drive. Conventional feedback systems like incremental, or sine, or BiSS, or EnDAT encoders are connected by separate feedback cables, which results in a dual cable connection to the drive.

Feedback functions are assigned with parameters in WorkBench, the setup software. Scaling and other settings are also performed in WorkBench. For a detailed description of the parameters, please refer to the WorkBench online help.

9.9.1 Motor single cable connection (X29, X30, X31)

Motors with single cable connection (motor power lines, motor holding brake lines and motor feedback lines combined in one hybrid cable) have one connector on the motor end and two or three connectors on the drive end.

MKD-N 6 A or 12 A axes

X29B and X31B are available in dual-axis modules only.

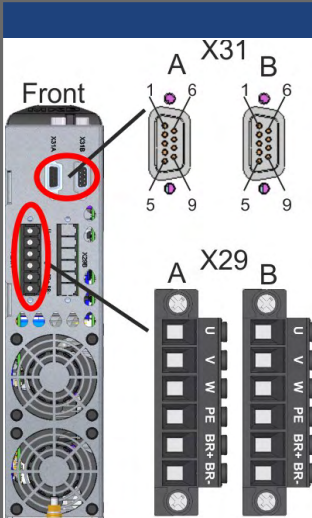

X29	Signal	Description
1	U	Motor phase U
2	V	Motor phase V
3	W	Motor phase W
4	PE	Protective earth (motor housing)
5	BR+	Motor Brake positive
6	BR-	Motor Brake negative
X31	Signal	Description
7	COM+	SFD3/DSL positive
8	COM-	SFD3/DSL positive

MKD-N 24 A or 48 A axes

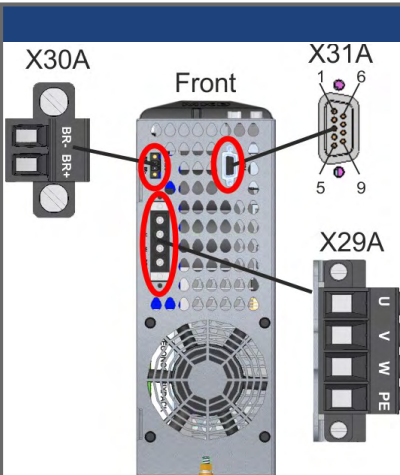

X29	Signal	Description
1	U	Motor phase U
2	V	Motor phase V
3	W	Motor phase W
4	PE	Protective earth (motor housing)
X30	Signal	Description
1	BR+	Motor Brake positive
2	BR-	Motor Brake negative
X31	Signal	Description
7	COM+	SFD3/DSL positive
8	COM-	SFD3/DSL positive

9.9.1.1 Motor Power and Motor Brake X29, Motor Feedback X31

Valid for MKD-N axes with 6 A or 12 A.

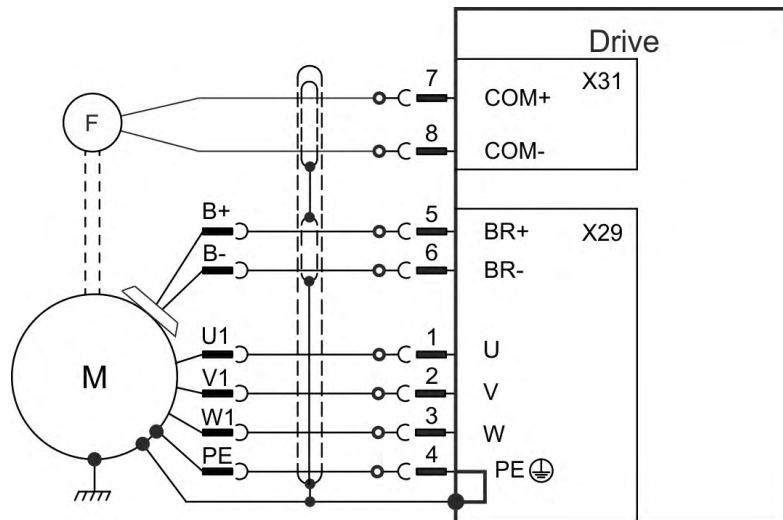

9.9.1.2 Motor Power X29, Motor Brake X30, Motor Feedback X31

Valid for MKD-N axes with 24 A or 48 A.

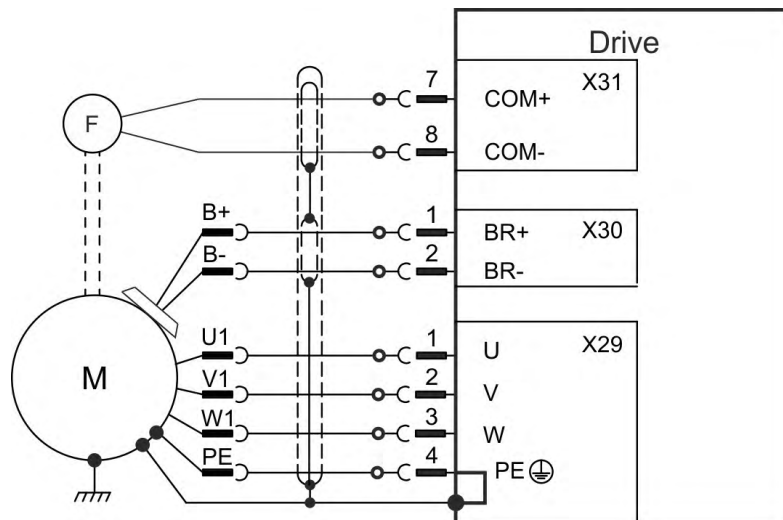

9.9.2 Motor dual cable connection (X29, X30, X32)

Motors with dual cables connection (motor power lines and motor feedback lines in separate cables).

MKD-N 6 A or 12 A axes

X29B and X32B are available in dual-axis modules only.

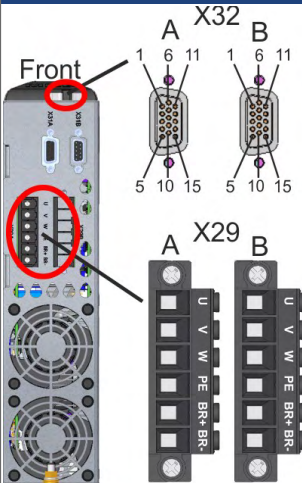

X29	Signal	Description
1	U	Motor phase U
2	V	Motor phase V
3	W	Motor phase W
4	PE	Protective earth (motor housing)
5	BR+	Motor Brake positive
6	BR-	Motor Brake negative
X32	Signal	Description
1...15	div	See (→ # 94)

MKD-N 24 A or 48 A axes

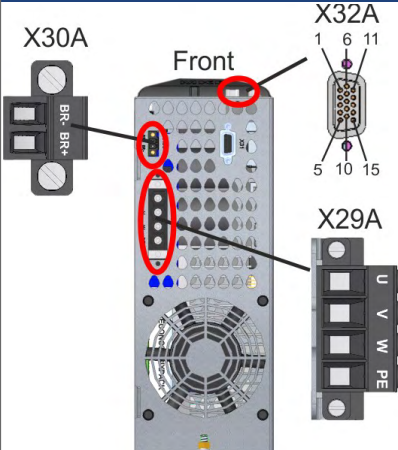

X29	Signal	Description
1	U	Motor phase U
2	V	Motor phase V
3	W	Motor phase W
4	PE	Protective earth (motor housing)
X30	Signal	Description
1	BR+	Motor Brake positive
2	BR-	Motor Brake negative
X32	Signal	Description
1...15	div	See (→ # 94)

9.9.2.1 Motor Power and Motor Brake X29

Valid for MKD-N axes with 6 A or 12 A.

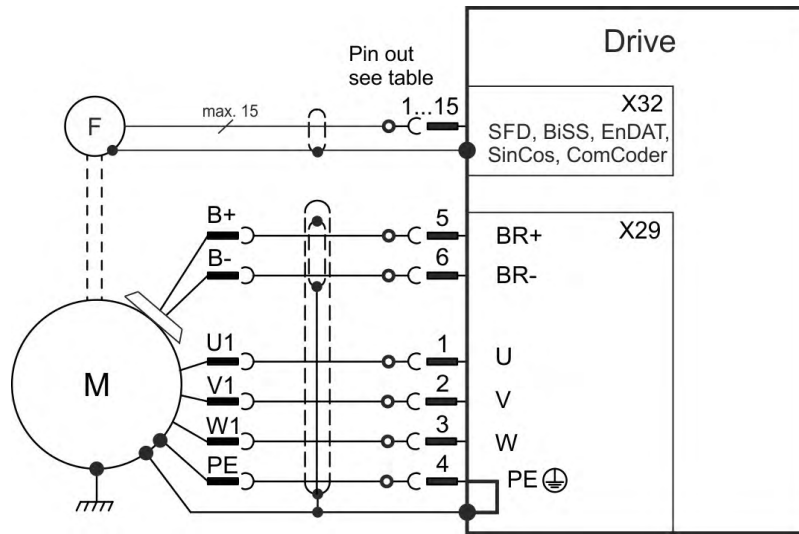

9.9.2.2 Motor Power X29, Motor Brake X30

Valid for MKD-N axes with 24 A or 48 A.

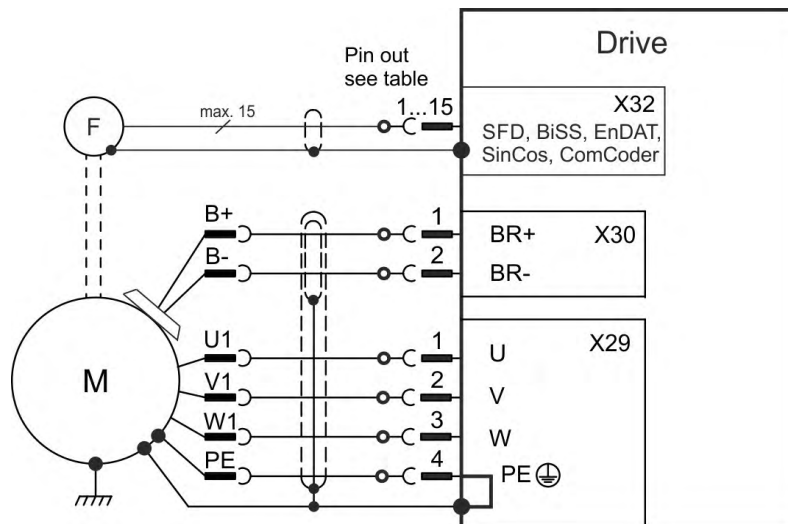

9.9.2.3 Motor Feedback X32

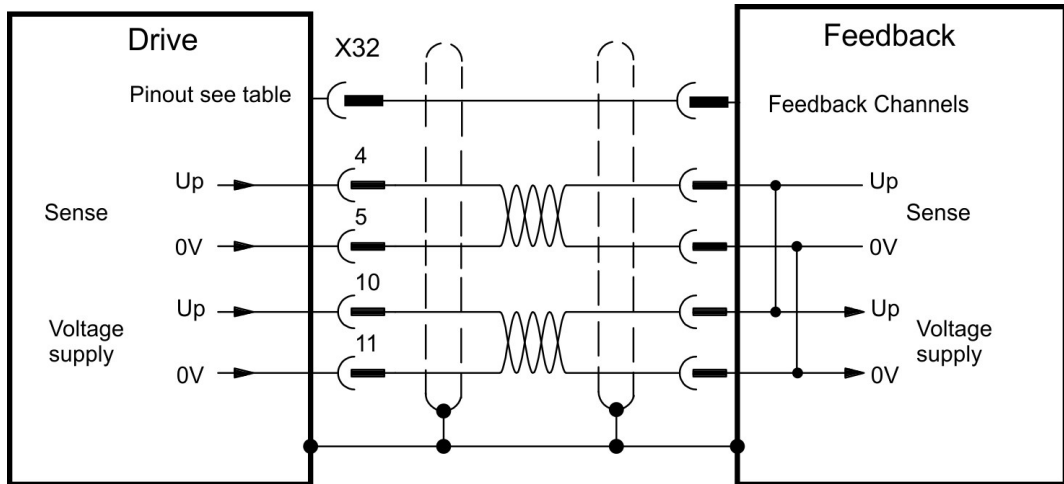

X32B is available in dual-axis modules only.

X32	SFD	BiSS B	BiSS C	EnDAT 2.1	EnDAT 2.2	Sine/Cos +Hall	Incr. Enc. +Hall
1	-	-	-	-	-	Hall U	Hall U
2	-	CLK+	CLK+	CLK+	CLK+	Hall V	Hall V
3	-	CLK-	CLK-	CLK-	CLK-	Hall W	Hall W
4	SEN+	SEN+	SEN+	SEN+	SEN+	SEN+	SEN+
5	SEN-	SEN-	SEN-	SEN-	SEN-	SEN-	SEN-
6	COM+	DAT+	DAT+	DAT+	DAT+	Zero+	Zero+
7	COM-	DAT-	DAT-	DAT-	DAT-	Zero-	Zero-
8	-	Thermal control (+)					
9	-	Thermal control (-)					
10	+5V	+5V	+5V	+5V	+5V	+5V	+5V
11	0V	0V	0V	0V	0V	0V	0V
12	-	A+	-	A+	-	A+	A+
13	-	A-	-	A-	-	A-	A-
14	-	B+	-	B+	-	B+	B+
15	-	B-	-	B-	-	B-	B-

CLK = CLOCK, DAT = DATA

BiSS Mode C interface from Renishaw (model Resolute RA26B)

9.10 Secondary Feedback Connection (X33)

It is possible to set up master/slave systems, use an external encoder as a command encoder, secondary feedback device (dual loop control) or connect the amplifier to a third party step controller. See the “Feedback 2” screen in WorkBench for setup.

NOTE

Don't use for primary motor feedback connection!

Connector X33 can be configured as an input for 5 V (TTL level) signals.

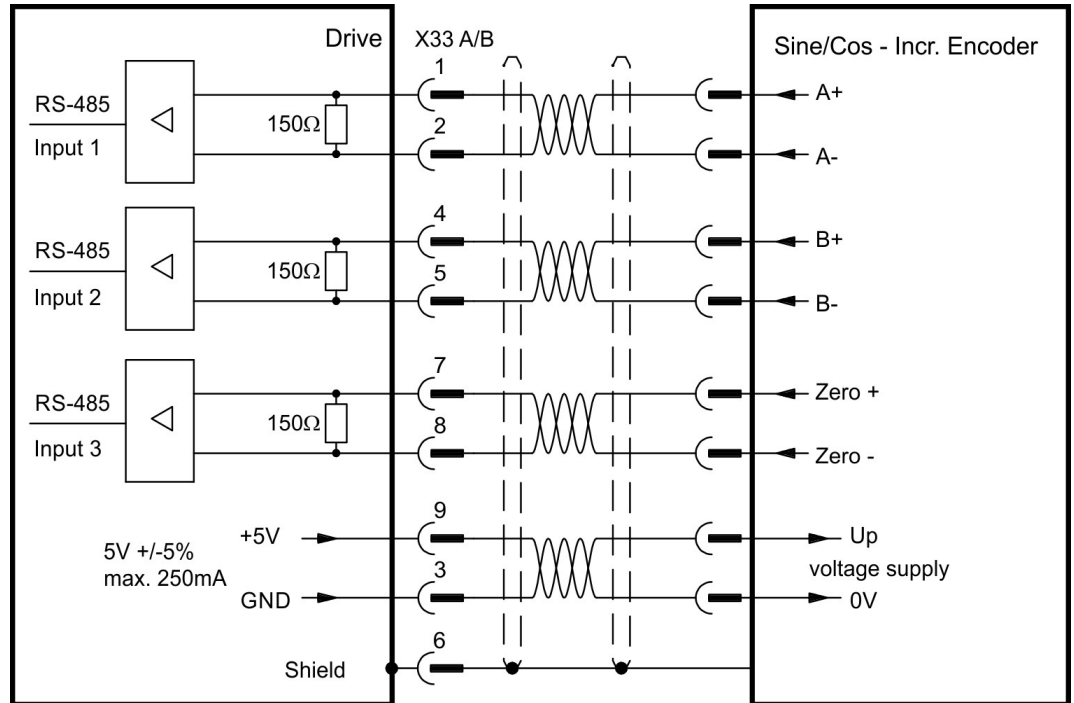
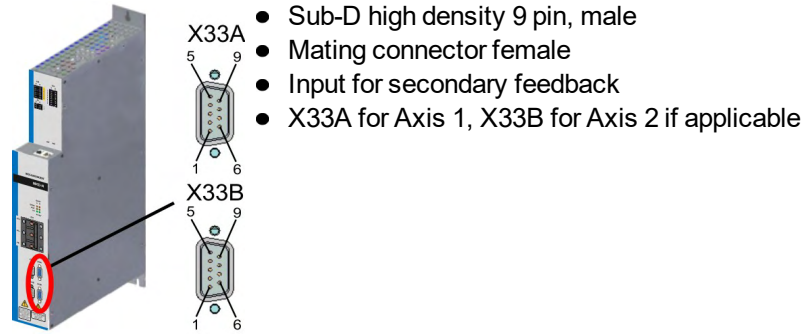

X33B is available in dual-axis modules only.

Pin	Sine / Cos	Incr. Enc.
1	A+	A+
2	A-	A-
3	0 V	0 V
4	B+	B+
5	B-	B-
6	Shield	Shield
7	Zero+	Zero+
8	Zero-	Zero-
9	+5 V	+5 V

9.11 I/O Connection

9.11.1 Technical Data Inputs/Outputs MKD-C

Interface	Electrical Data
Digital inputs (X15B)	<ul style="list-style-type: none"> ● as per IEC61131-2 type 1 ● ON: 15 VDC to 30 VDC, 2 mA to 15 mA ● OFF: -3 VDC to 5 VDC, < 1 mA ● update rate 250 μs ● galvanic isolation for 250 VDC
Digital outputs (X15B)	<ul style="list-style-type: none"> ● as per IEC61131-2 type 1 ● max. 30 VDC, 100 mA ● short circuit proof ● galvanic isolation for 250 VDC
Relay output (X15A)	<ul style="list-style-type: none"> ● max. 30 VDC, 1 A ● max. 42 VAC, 1 A ● time open/close 10ms ● isolation 400 VDC contact/coil
STO-Enable inputs (X16A/B)	<ul style="list-style-type: none"> ● ON: 18 VDC to 30 VDC, 50 mA to 100 mA ● OFF: 0 VDC to 12 VDC, < 50 mA ● immunity 60 VDC
STO-Status outputs (X15A)	<ul style="list-style-type: none"> ● as per IEC61131-2 type 1 ● max. 30 VDC, 100 mA ● galvanic isolation for 250 VDC

9.11.2 Technical Data Inputs/Outputs MKD-N

Interface	Electrical Data
Digital inputs (X24)	<ul style="list-style-type: none"> ● as per IEC61131-2 type 1 ● ON: 15 VDC to 30 VDC, 2 mA to 15 mA ● OFF: -3 VDC to 5 VDC, < 1 mA ● galvanic isolation for 30 VDC ● 2 high speed inputs: update rate 2 μs ● 1 standard input: update rate 250 μs
Digital output (X24)	<ul style="list-style-type: none"> ● as per IEC61131-2 type 1 ● max. 30 VDC, 100 mA ● short circuit proof ● galvanic isolation for 30 VDC ● Update rate 250 μs
STO input (X26)	<ul style="list-style-type: none"> ● ON: 18 VDC to 30 VDC, 50 mA to 100 mA ● OFF: 0 VDC to 12 VDC, < 50 mA ● immunity 60 VDC
STO outputs (X24)	<ul style="list-style-type: none"> ● as per IEC61131-2 type 1 ● max. 30 VDC, 100 mA ● short circuit proof ● galvanic isolation for 30 VDC ● Update rate 62.5 μs

9.11.3 Pinout MKD-C I/O connectors X15 and X16



Digital I/O signals are connected to X15A and X15B

X15A Pin	Signal	Abbreviation	Function	Wiring Diagram
1	Relay Output +	Relay +	Relay Output, programmable	(→ # 101)
2	Relay Output -	Relay -		
3	STO Status String 2+	STO-Status 2+	Global STO Status of String 2	(→ # 110)
4	STO Status String 2-	STO-Status 2-		
5	STO Status String 3+	STO-Status 3+	Global STO Status of String 3	
6	STO Status String 3-	STO-Status 3-		

X15B Pin	Signal	Abbreviation	Function	Wiring Diagram
1	Digital Input 1	Digital-In 1	Enable, programmable	(→ # 99)
2	Digital Input 2	Digital-In 2	Programmable	
3	Digital Input 3	Digital-In 3	Programmable	
4	Digital Common	DCOM	Common line for digital inputs	(→ # 101)
5	Digital Output +	Digital-Out+	Transistor Output, programmable	
6	Digital Output -	Digital-Out-		

STO signals are connected to X16A and X16B

X16A Pin	Signal	Abbreviation	Function	Wiring Diagram
1	+ 24 V STO	+ 24 V STO	24V STO supply voltage	(→ # 110)
2	STO-Enable String 2 +	STO String 2 +	Global STO Enable of String 2	
3				
4	STO-Enable String 2 -	STO String 2 -		
5				
6	STO Ground	GND STO	Ground of 24 V STO supply	

X16B Pin	Signal	Abbreviation	Function	Wiring Diagram
1	+ 24 V STO	+ 24 V STO	24V STO supply voltage	(→ # 110)
2	STO-Enable String 3 +	STO String 3 +	Global STO Enable String of 3	
3				
4	STO-Enable String 3 -	STO String 3 -		
5				
6	STO Ground	GND STO	Ground of 24 V STO supply	

9.11.4 Pinout MKD-N I/O connectors X24 and X26

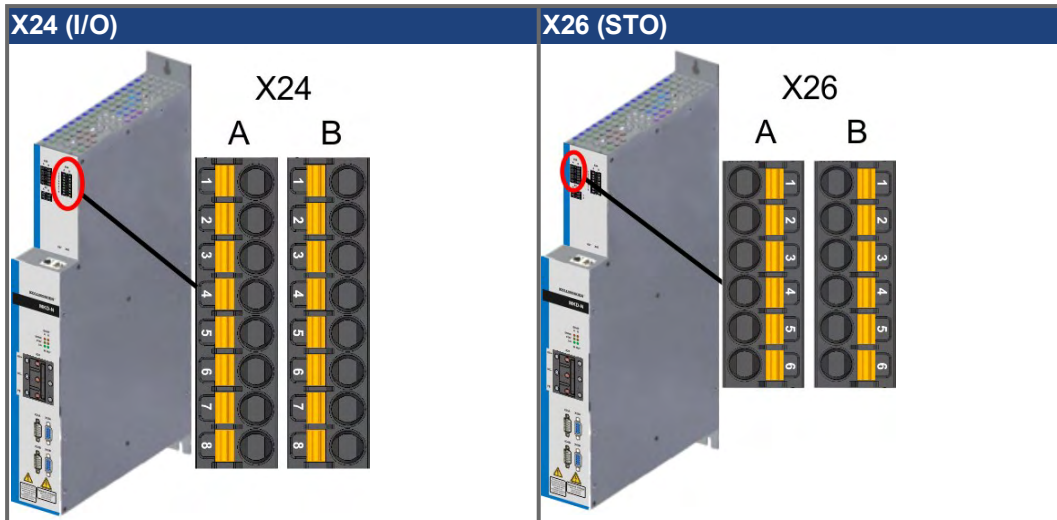

Digital I/O signals are connected to X24A (axis 1) and X24B (axis 2 if available)

X24 Pin	Signal	Abbreviation	Function	Wiring Diagram
1	Digital Input 1	Digital-In 1	Enable, programmable	(→ # 99)
2	Digital Input 2	Digital-In 2	Programmable	
3	Digital Input 3	Digital-In 3	Programmable	
4	Digital Common	DCOM	Common line for digital inputs	
5	Digital Output +	Digital-Out+	Transistor Output, programmable	(→ # 101)
6	Digital Output -	Digital-Out-		
7	STO Status Out+	STO-Status +	Local STO Status	(→ # 114)
8	STO Status Out-	STO-Status -		

STO signals are connected to X26A (axis 1) and X26B (axis 2 if available)

X26 Pin	Signal	Abbreviation	Function	Wiring Diagram
1	+ 24 V STO	+ 24 V STO	24V STO supply voltage	(→ # 114)
2	STO-Enable +	STO +	Local STO Enable +	
3				
4	STO-Enable -	STO -	Local STO Enable -	
5				
6	STO Ground	GND STO	Ground of 24 V STO supply	

9.11.5 Wiring of Digital Inputs (X15, X16, X24, X26)

All digital inputs can be used to initiate pre-defined functions. A list of these pre-defined functions is included in the WorkBench. If an input is programmed, it must be saved to the device memory. For more information refer to the setup software.

NOTE

Depending on the selected function, the inputs are high or low active. The inputs can be used with switched +24 V (source type) or switched GND (sink type). Digital input filter can be set in WorkBench to change sensitivity of the inputs (see Online Help).

9.11.5.1 Digital Inputs MKD-C (X15B)

Technical characteristics:

- Floating, reference common line is DCOM
- Sink or Source type sensors possible
- High: 15 to 30 V / 2 to 15 mA , Low: -3 to +5 V / <1 mA
- Update rate: firmware reads hardware input state every 250 μ s

Wiring diagram:

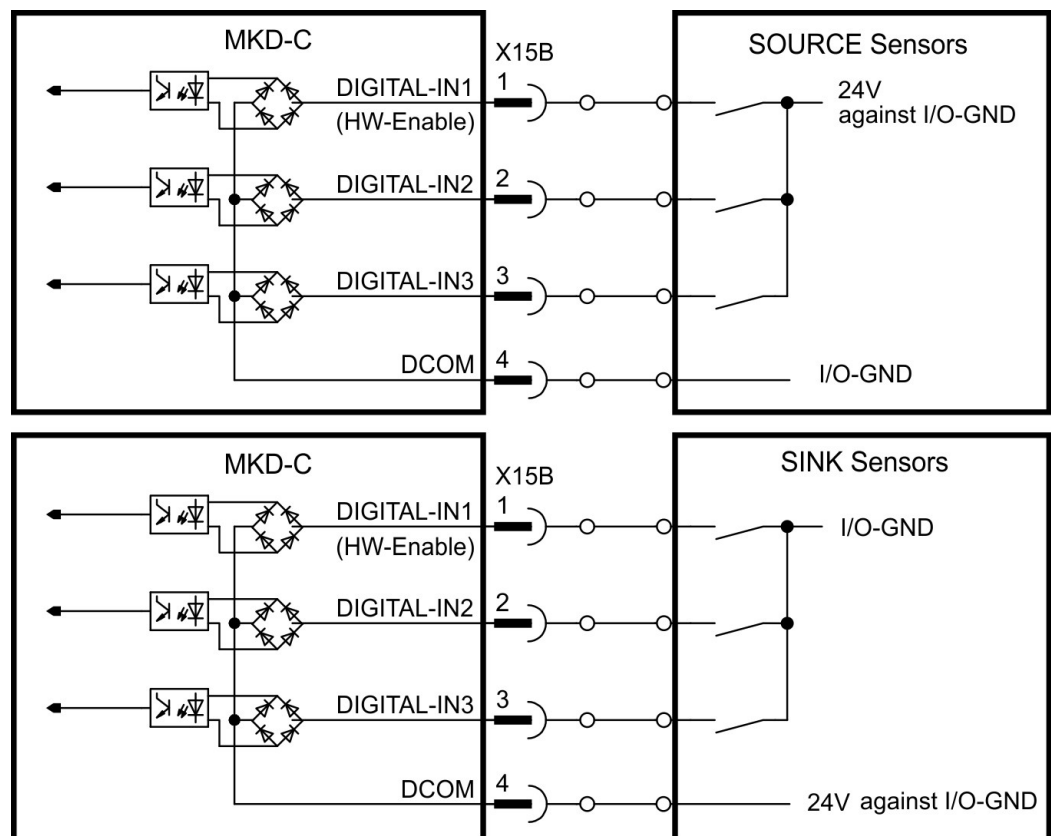

Hardware Enable

Digital Input (terminal X15B/1) is set to the Hardware Enable function by default.

NOTE

The Hardware Enable and the Software Enable signal (via fieldbus or WorkBench) are linked serial, that means wiring of Hardware Enable is mandatory.

The output stage of all drives, which are connected to the MKD-C are enabled by applying the ENABLE signal (Terminal X15B/1). Enable is possible only if the input STO-String 2 or 3 (valid for DC power strings 2 or 3) have a 24 V signal (→ # 105) and Software Enable is set. In the disabled state the connected motors have no torque.

9.11.5.2 Digital Inputs MKD-N (X24)

On dual axis MKD-N modules connector X24A is used for axis 1, X24B is used for axis 2.

Digital Inputs 1 and 2

These inputs are particularly fast and are therefore suitable for latch functions, for example.

Technical characteristics:

- Floating, reference common line is DCOM
- Sink or Source type sensors possible
- High: 15 to 30 V / 2 to 15 mA , Low: -3 to +5 V / <1 mA
- Update rate: firmware reads hardware input state every 250 μs
- High accuracy latch: motor feedback position or interpolated time is latched or captured within 2 μs of input signal transition (with digital input filter set to 40 ns)
- The MKD capture engine is polled every 62.5 μs (16 kHz) by the firmware

Digital Input 3

Technical characteristics:

- Floating, reference common line is DCOM
- Sink or Source type sensors possible
- High: 15 to 30 V / 2 to 15 mA , Low: -3 to +5 V / <1 mA
- Update rate: firmware reads hardware input state every 250 μs

Wiring diagram:

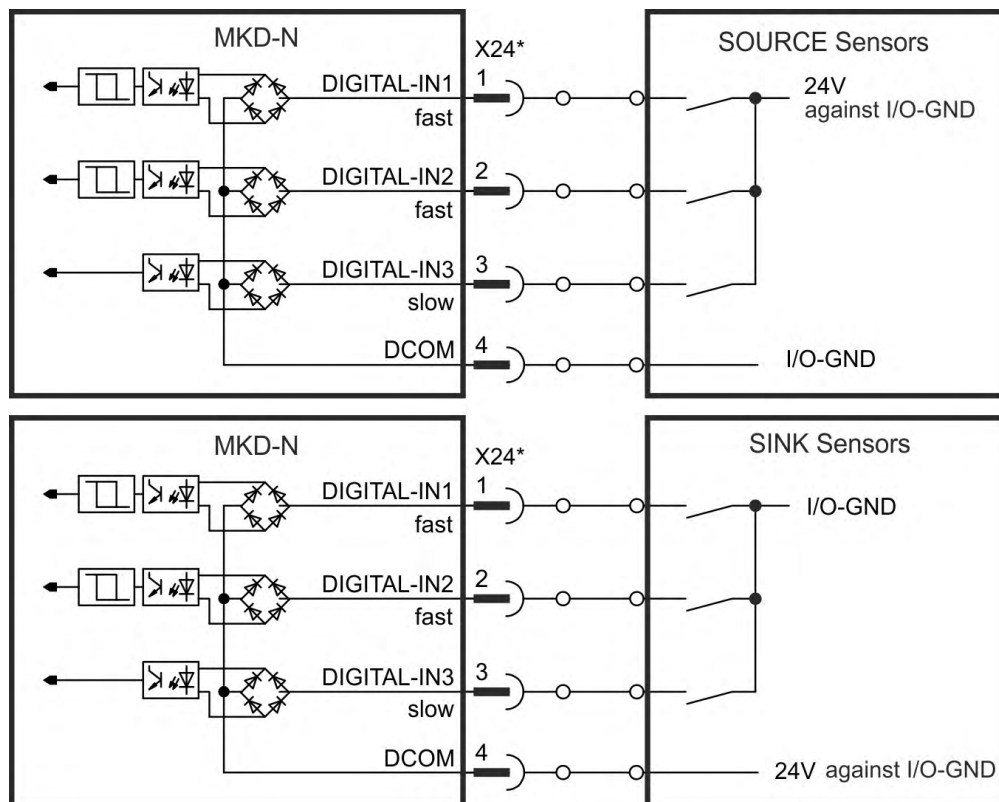

* On MKD-N connector X24A is used for axis 1, X24B is used for axis 2 if built-in.

9.11.5.3 STO Enable inputs (X16, X26)

Connector X16 on MKD-C offers access to all global STO input signals of the decentral drive system powered by this MKD-C . There is one STO-Enable input for each decentral DC Power string (strings 2 and 3).

Connector X26 on MKD-N offers access to local STO input signals of the included axes in the MKD-N module. There is one local STO-Enable input for each axis.

For description of STO interface and functionality refer to (→ # 105).

9.11.6 Wiring of Digital Outputs (X15, X24)

Digital I/O connectors X15A, X15B on MKD-C and X24A, X24B on MKD-N supply programmable digital outputs, (→ #96). Choose the required function in the setup software. A list of these pre-defined functions can be found in the setup software. If the output is to be assigned to a pre-defined function, then the parameter set must be saved in the device memory.

9.11.6.1 Transistor Outputs (X15B, X24)

Technical characteristics:

- As per IEC61131-2 type 1
- Floating, max. 30 VDC, 100 mA
- Short circuit proof
- Galvanic isolation for 250 VDC
- Can be wired as sink or source (see examples below)
- Update rate: 250 μs

Wiring diagram:

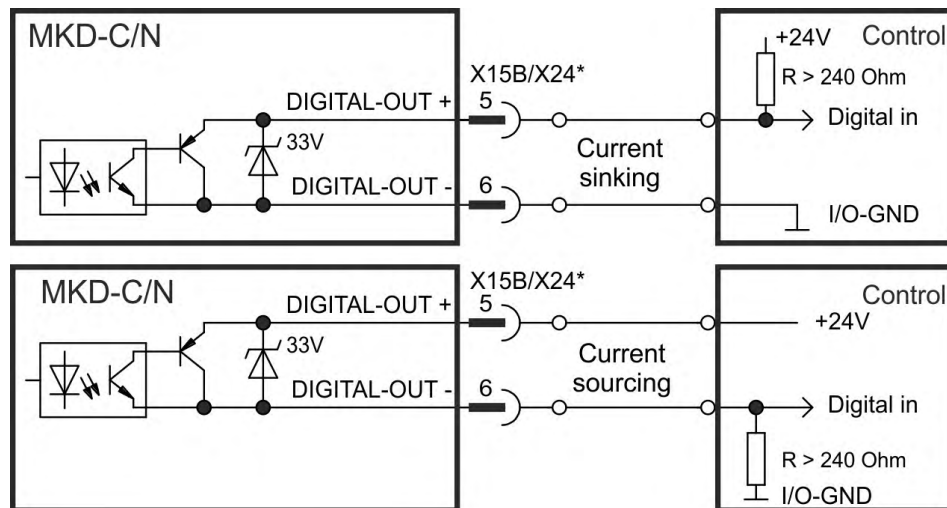

* On MKD-N connector X24A is used for axis 1, X24B is used for axis 2 if built-in.

9.11.6.2 Relay Output (X15A)

Operational readiness can be signaled by these floating relay contacts. With the relay output set to be a fault relay, there are two modes of operation:

- Contact closed when there is no fault
- Contact closed when there is no fault and the drive is enabled.

Technical characteristics:

- Relay output, max. 30 VDC or 42 VAC, 1 A
- Time to close: max. 10 ms
- Time to open: max. 10 ms

Wiring diagram:

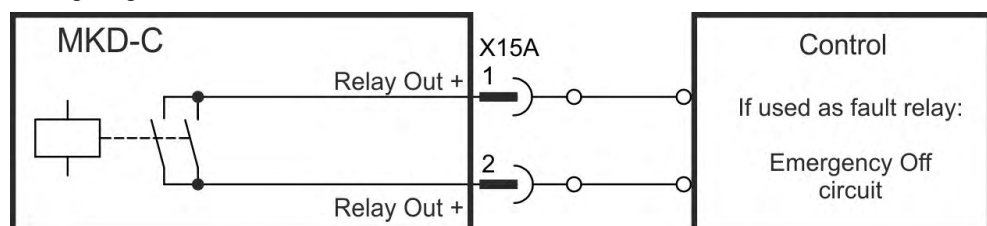

9.11.6.3 STO Status Outputs (X15A, X24)

NOTE

STO Status signals can be used for information only. The signals should not be used for functional safe operations.

For detailed description of STO functionality refer to (→ # 105).

Technical characteristics:

- As per IEC61131-2 type 1
- Floating, max. 30 VDC, 100 mA
- Short circuit proof
- Galvanic isolation for 250 VDC
- Can be wired as sink or source (current sourcing in the example below)
- Update rate: 250 μ s

Wiring diagram:

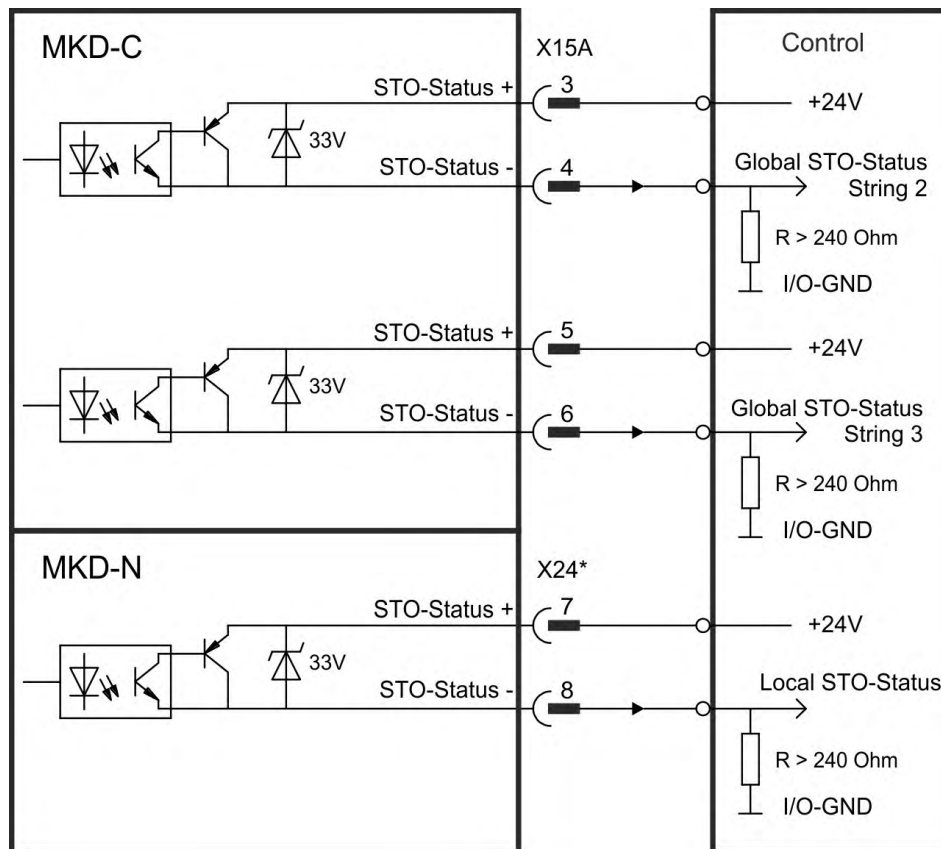

* On MKD-N connector X24A is used for axis 1, X24B is used for axis 2 if built-in.

9.12 Motion Bus Interface (X10/X11)

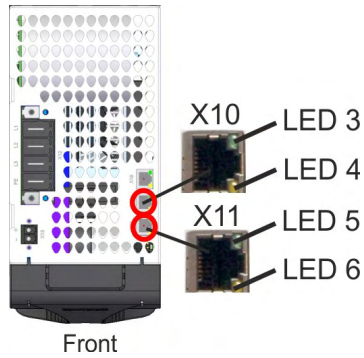

The motion bus interface has RJ-45 connectors and can be used for communication with the EtherCAT master and other MKD-C.

NOTICE

Do not connect the Ethernet line for the PC or PAC with the setup software to the motion bus interface X10/X11. The setup Ethernet cable must be connected to X18.

The communication status is indicated by the built-in connector LEDs.

Connector	LED#	Name	Function
X10	LED3	Link	ON = active, OFF= not active
	LED4	-	-
X11	LED5	Link	ON = active, OFF = not active
	LED6	-	-

9.12.1 Pinout

Pin	Signal X10	Signal X11
1	Transmit +	Receive+
2	Transmit -	Receive-
3	Receive+	Transmit +
4, 5	n.c.	n.c.
6	Receive-	Transmit -
7, 8	n.c.	n.c.

9.12.2 EtherCAT

MKD-C can be connected as slaves to the EtherCAT network (CoE) via RJ-45 connectors X10 (in port) and X11 (out port).

9.13 Service Interface (X18)

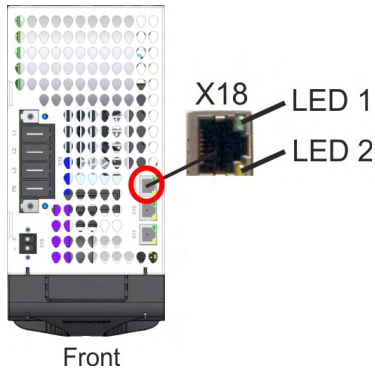

Operating, position control, and motion-block parameters can be set up by using the setup software WorkBench on an ordinary commercial PC (→ # 122).

Connect the service interface X18 to an Ethernet interface on the PC directly or via a network switch. The cable can be connected/disconnected to/from X18 with power on.

NOTE The X18 service port of an MKD-C does **not** allow access to MKD-N drives connected to another MKD-C devices.

Confirm that the link LED on the MKD-C (the green LED on the RJ45 connector) and on your PC (or network switch) are both illuminated. If both lights are illuminated, then you have a good electrical connection.

LED#	Name	Function
LED1	Link	ON = active, OFF= not active
LED2	Activity	ON = running, OFF = not running

9.13.1 Pinout

Pin	Signal	Pin	Signal
1	Transmit +	5	n.c.
2	Transmit -	6	Receive-
3	Receive+	7	n.c.
4	n.c.	8	n.c.

9.13.2 Service Bus Protocols

Protocol	Type
Ethernet TCP/IP	Service Bus, 100 Mbit/s

NOTE Network hubs and transfer rate of 10 Mbit/s are not supported.

10 Functional Safety

Valid for MKD Hardware Revision A.

NOTICE

Safety functionality is not approved nor certified. Do not use this functionality in applications with functional safety request until further notice.

10.1 STO (Safe Torque Off)

10.1.1 STO Safety instructions



WARNING No Brake Power!

Serious injury could result when a suspended load is not properly blocked. The drive cannot hold a vertical load when STO is active.

- Add a safe mechanical blocking (for instance, a motor-holding brake).
- The drives have not to be used for driving elevators.



WARNING Automatic Restart!

Risk of death or serious injury for humans working in the machine. The drive might restart automatically after power on, voltage dip or interruption of the supply voltage, depending on the parameter setting. If parameter DRV.ENDEFAULT for one MKD-N or AKD-N is set to 1,

- then place a warning sign ("WARNING: Possible Automatic Restart" or similar) to the machine.
- Ensure, that power on is not possible, while humans are in a dangerous zone of the machine.
- In case of using an undervoltage protection device, you must observe EN 60204-1:2006 chapter 7.5 .



CAUTION High electrical voltage!

Risk of electrical shock! The STO function does not provide an electrical separation from the power output. If access to the motor power terminals is necessary,

- disconnect the drive from mains supply,
- consider the discharging time of the DC-Bus link.

NOTICE

If the safety function STO is automatically activated by a control system, then make sure that the output of the control is monitored for possible malfunction. The monitoring can be used to prevent a faulty output from unintentionally activating the STO function.

NOTICE

It is not possible to perform a controlled brake if the drive controlled STO is off. If controlled braking before the use of the STO function is necessary, the drive must be braked and the STO input must be disconnected from +24 V time-delayed.

NOTICE

In case of a specific double fault within a very short time a single movement of a maximum angle of 120° (electrical) can happen. This effect can only happen if the drive is in the function STO. Even if the STO function will be issued for a whole year, this event will only happen every 100 Billion years.

NOTE

The STO Status signals are informal and not relevant for functional safety.

10.1.2 Use as directed

The STO function is exclusively intended to provide a functional safe torque off of the motion system. To achieve this functional safety, the wiring of the safety circuits must meet the safety requirements of IEC 60204, ISO 12100 and ISO 13849.

STO inputs must be connected to the exit of a safety control or a safety relay, which at least meets the requirements of PLd, CAT 3 according to ISO 13849.

The 24 VDC supply unit for global and local STO supply must accord to PELV (EN 60204-1) requirements and must not be used for drive power supply.

10.1.3 Prohibited use

The STO function must not be used if the drive is to be made inactive for the following reasons:

- Cleaning, maintenance and repair operations, long inoperative periods. In such cases, the entire system should be disconnected from the supply and secured (main switch).
- Emergency-Off situations. In an Emergency-Off situation, the main contactor is switched off (by the Emergency-Off button).

Wiring the system with hybrid cables from other manufacturers than Kollmorgen is not allowed. Changing cables or connectors is not allowed.

MKD-N have not to be used for driving elevators.

Do not use STO Status signals for functional safety.

10.1.4 Enclosure, wiring

Ambient conditions

For MKD-C/N observe the required ambient conditions as described in chapter (→ # 38).

The MKD-C/N (IP 20) must be mounted in an IP54 cabinet to ensure pollution level 2 according to IEC 60664-1. Connector X16/X26 (STO signals) ensures requirements of pollution level 3 according to IEC 60664-1.

For AKD-N refer to the ambient conditions described in the *AKD-N Installation Manual*. The AKD-N can be used in an environment that requires IP67 devices.

Wiring inside the cabinet

Wiring remaining must meet the requirements of the standard IEC 60204-1. In compliance with the safety standard ISO 13849-2 Table D.4; short-circuits between conductors or of any conductor to an exposed conductive part can be excluded when:

- permanently connected (fixed) and protected against external damage, e. g. by cable ducting, armouring, or
- within separate multicore cables, or
- within the IP54 electrical enclosure, or
- individually shielded with earth connection.

This is valid for the STO wiring of MKD-C and MKD-N.

Wiring outside the cabinet

If you are wiring leads that are outside the specified enclosure (IP54), the cables must be laid durably (firmly), protected from outside damage (for example, by laying the cable in a duct), placed in different sheathed cables, or protected individually by grounding connection.

Maximum cable length

Maximum cable length for safety relevant I/Os and for the 24 V supply (PELV) is 30 m.

10.1.5 Topology overview

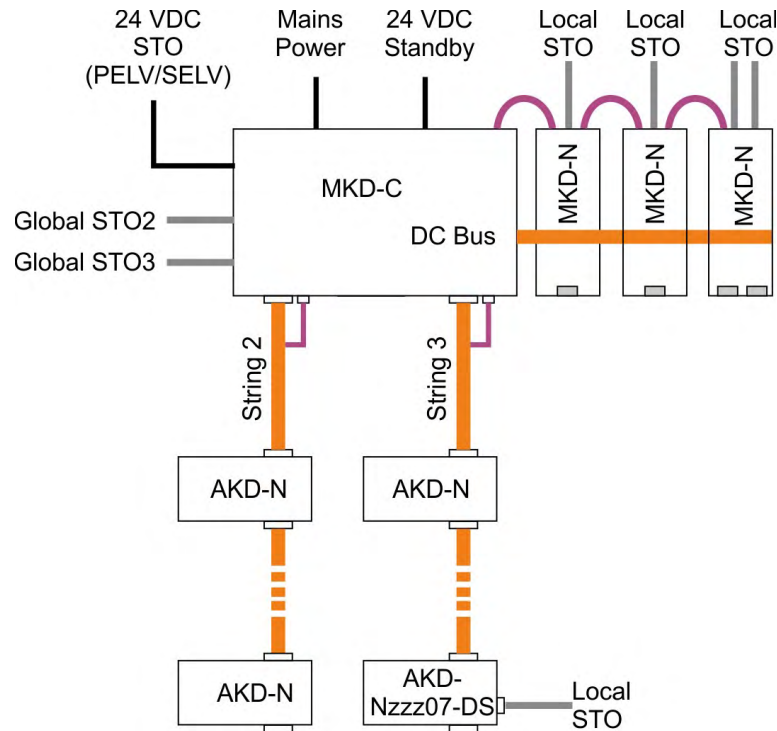

- MKD-C connector X16:
 - global STO (String 2/3) inputs of the system powered by this MKD-C.
- MKD-C connector X15A:
 - global STO (String 2/3) status output of the system powered by this MKD-C.
- MKD-N connector X26:
 - local STO (axis 1 and axis 2 if built-in) input of the drive module.
- AKD-N connectors X3/X6:
 - local STO input (X6) and status output (X3) of the AKD-N-DS/DT drive modules.

10.1.6 OSSD test pulses

Safety controllers usually check their outputs periodically during the normal operation. These test procedures create pulses to the STO-Enable inputs.

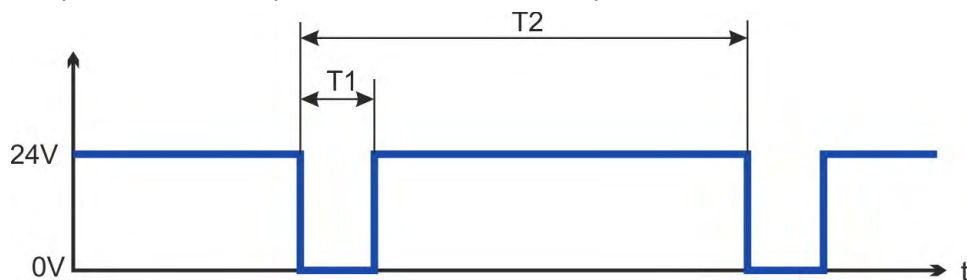

Test pulses with $T1 \leq 300 \mu\text{s}$ and $T2 \geq 200 \text{ms}$ will not have any influence to the safety relevant STO function. Test pulses, which are outside of this specification, will switch the STO function, but will not create a dangerous situation.

10.1.7 STO 24 VDC voltage supply

Use a PELV power supply for both global and local STO 24V DC supply.

STO 24 VDC supply	<ul style="list-style-type: none"> ● PELV acc. to EN 60204-1 ● Output 24 VDC +/-10% ● Maximum 4.2 A with 42 drive axes ● Do not use for power stand by functionality
-------------------	--

10.1.8 Safety characteristic data

NOTICE Safety functionality is not approved nor certified. Do not use this functionality in applications with functional safety request.

10.1.9 Response Time

Local STO (MKD-N)

The delay from falling edge at local STO Enable input until energy supply to the motor is interrupted is maximum 10 ms.

Global STO (Strings 2/3, AKD-N)

The delay from falling edge at global STO Enable input until energy supply to the motors is interrupted, depends on the number of connected MKD-N to the string. Maximum reaction time is 10 ms. The more MKD-N are connected to the string, the shorter is the reaction time.

10.1.10 Signal diagram (sequence)

The diagram below shows how to use global STO function for a safe drive stop and fault free operation of the drives connected to one of the strings.

1. Brake the drives in a controlled manner (speed setpoint = 0 V).
2. When speed = 0 rpm, disable the drives (Enable = 0 V).
3. Activate the STO function (STO input = 0 V)
4. For restart you must reset the safety device.

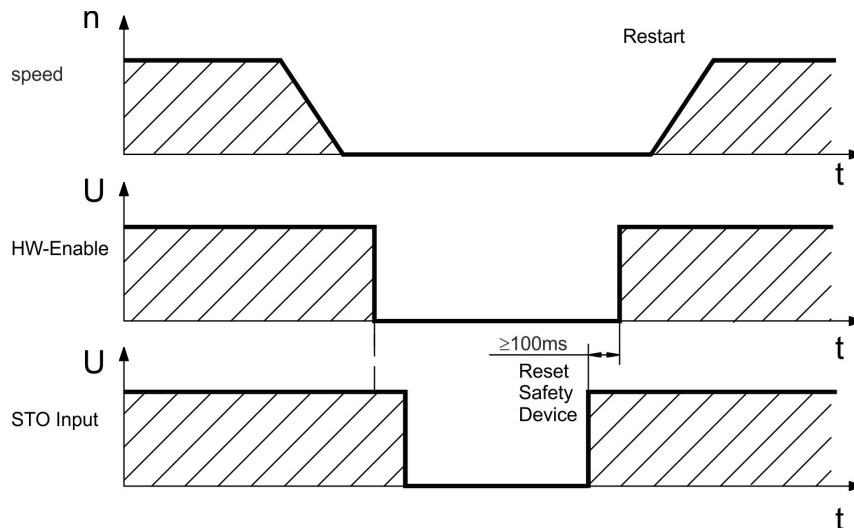

10.1.11 Global Safe Torque Off (Strings 2 or 3)

10.1.11.1 General information

NOTE

The global STO function uses the following devices: MKD-C, AKD-N without option "DS" or "DT", Kollmorgen hybrid connection string cable.

There is one STO input and one STO-Status output for every DC Power string.

The string STO input release the power output stage of all AKD-N (without option DS/DT) connected to the string as long as a 24 V signal is applied to this input. If the STO-Enable goes open-circuit, then power will no longer be supplied to the connected motors, and the drives will lose all torque and coast to a stop.

NOTE

In case of using AKD-N with option "DS" or "DT" (local STO input), the global STO signal will have no influence to these specific drives.

NOTE

In case of using more than 8 AKD-N in one string, you must connect a signal buffer to the STO signal.

10.1.11.2 Technical data and connection

NOTE

The global STO inputs are not compatible with IEC 61131-2. Connector X16 ensures requirements of pollution level 3 according to IEC 60664-1.

STO String X inputs	<ul style="list-style-type: none"> ● ON: 18 VDC to 30 VDC, 50 mA to 100 mA ● OFF: 0 VDC to 12 VDC, < 50 mA ● Immunity 60 VDC ● Signal buffer required if more than 8 AKD-N are connected to one string
STO-Status outputs	<ul style="list-style-type: none"> ● As per IEC61131-2 type 1 ● Max. 30 VDC, 100 mA ● Galvanic isolation for 250 VDC

Pinout connector STO signals

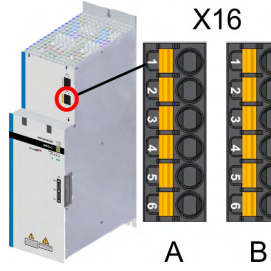

X15 A	Outputs	X16 A	Inputs String 2	X16 B	Inputs String 3
1	Relay +	1	STO +24 V	1	STO +24 V
2	Relay -	2	STO String 2+	2	STO String 3+
3	STO-Status 2+	3		3	
4	STO-Status 2-	4	STO String 2-	4	STO String 3-
5	STO-Status 3+	5		5	
6	STO-Status 3-	6	STO GND	6	STO GND

Wiring diagram STO Signals, example

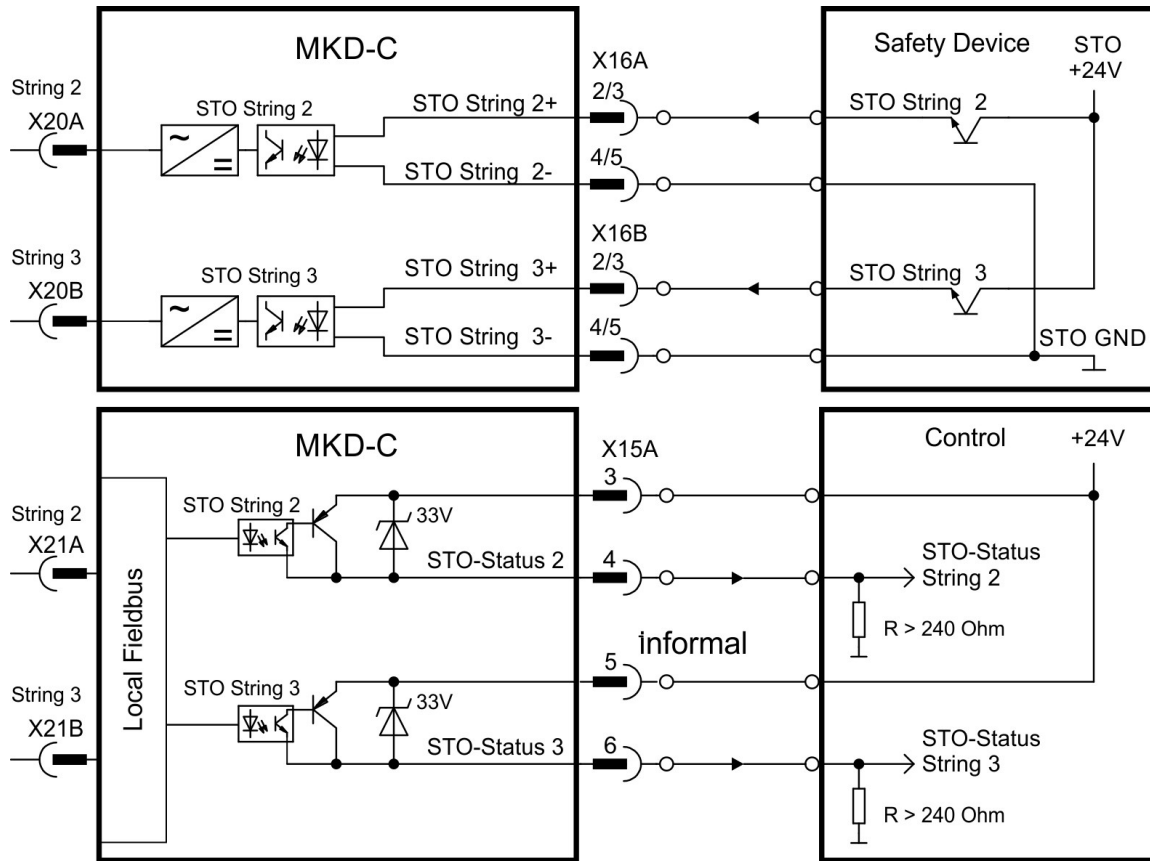

10.1.11.3 Global STO application example

The sample application below shows door guarding and emergency stop, controlled by a safety control to switch the global STO inputs of an MKD-C device to SIL2, PLd. Both drive strings are switched independently.

NOTE Kollmorgen KSM modules cannot be used.

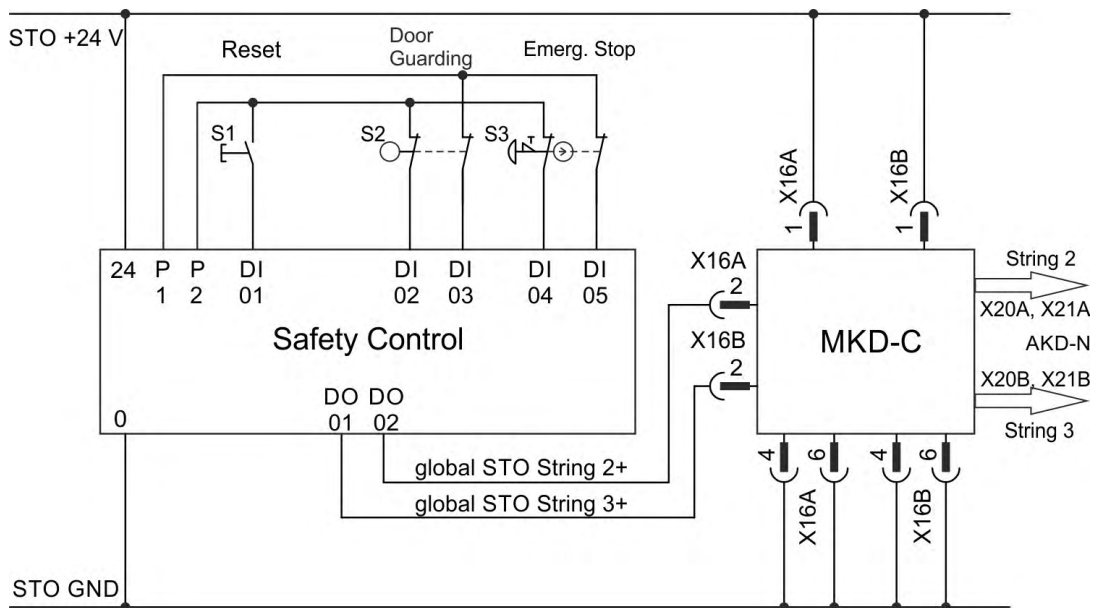

10.1.11.4 Functional description

There is one STO input and one STO-Status output for each string. The string STO input releases the power output stage of all MKD-N (without option "DS" or "DT") connected to the string as long as a 24 VDC signal is applied to this input. When STO function is engaged during operation by separating STO from 24 V, the drives (without option DS/DT) connected to the string slow down without control.

When the global STO function (Safe Torque Off) is not needed, then the inputs STO inputs must be connected directly to +24 VDC. The function is then bypassed and cannot be used in the machinery safety concept.

NOTE

In case of using an MKD-N with option "DS" or "DT" (local STO input) in the string, then the string STO signal will have no influence to this specific drive. The local STO-Status of this drive nevertheless is monitored in the string STO-Status.

NOTE

The string STO-Status output at the MKD-C is a logical OR of all STO-Status of the AKD-N drives connected to that respective string. STO-Status is high:

- during system boot (power up), or
- if the string STO input is 0V, or
- if the communication with one of the connected drives is lost, or
- if no drive is connected to the string, or
- if the local fieldbus doesn't work.

Possible states of the drives connected to the string referring to the global STO function:

String STO	String HW Enable	String STO-Status	Safety acc. to SIL2	MKD-N on String can produce Torque
0 V	no	high	yes	no
0 V	yes	high	yes	no
+24 V	no	low	no	no
+24 V	yes	low	no	yes

NOTICE

Use the following functional sequence when the STO function is used:

1. Brake the drives in a controlled manner (speed setpoint = 0 V).
2. When drives speed = 0 rpm, disable the string (enable = 0 V).
3. If a suspended load is present, block the drive mechanically.
4. Activate the STO function.

NOTE

It is not possible to perform a controlled brake if the STO is off. If controlled braking prior to the use of the STO function is necessary, the drive must be braked first and the STO input must be separated from +24 V time-delayed.

NOTE

When wiring the STO circuits within a enclosure, the cables and the enclosure must meet the requirements of IEC 60204-1. If you are wiring leads outside the specified enclosure, then the cables must be laid durably and protected from outside damage. Use Kollmorgen cables only.

10.1.11.5 Functional test

NOTICE

You must test the safe torque off function after initial start of the drive, after each interference into the wiring of the drive, or after exchange of one or several components of the drive.

First Method:

1. Stop drives in the string with setpoint 0 V. Keep drives enabled.
DANGER: Do not enter hazardous area!
2. Activate the global STO function for example by opening protective screen of the string, where the drives are connected (voltage at STO input = 0V).
3. The MKD-C fault contact opens, the corresponding string STO-Status message changes the voltage level, the drives lose torque and slow down to zero speed without control.

Second Method:

1. Stop all drives in the string with setpoint 0 V, disable the string.
2. Activate the global STO function, for example, by opening protective screen (voltage at STO input = 0V).
3. The corresponding string STO-Status message changes the voltage level, the string cannot be enabled.

10.1.12 Local STO on MKD-N

10.1.12.1 General information

There is one STO input on X26 and one STO-Status output on X24 for every drive axis.

10.1.12.2 Enclosure, wiring

NOTE

Avoid pollution of the connectors with conductive obstacles. Observe the required ambient conditions as described in chapter (→ # 38).

The cables must be laid durably (firmly), protected from outside damage (for example, by laying the cable in a duct), placed in different sheathed cables, or protected individually by grounding connection. Wiring must meet the requirements of the standard IEC 60204-1.

Maximum cable length for safety relevant I/Os and for the 24 V supply is 30 m.

10.1.12.3 Technical data and connection

NOTE

The local STO input is not compatible with IEC 61131-2. Connector X26 ensures requirements of pollution level 3 according to IEC 60664-1.

STO inputs	<ul style="list-style-type: none"> ● ON: 18 VDC to 30 VDC, 100 mA ● OFF: 0 VDC to 12 VDC, < 50 mA ● Immunity for 60 VDC ● Tolerated OSSD pulse duration 0.3 ms and minimum pulse duty cycle of 200 ms
STO-Status outputs	<ul style="list-style-type: none"> ● As per IEC61131-2 type 1 ● Max. 30 VDC, 100 mA ● Galvanic isolation for 250 VDC

Pinout connector STO input signals

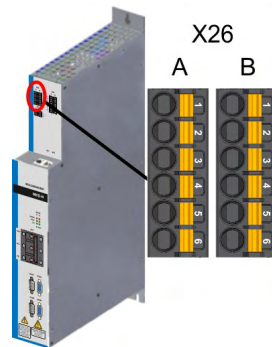

X26 A	Axis 1	X26 B	Axis 2
1	STO +24 V	1	STO +24 V
2	STO +	2	STO +
3		3	
4	STO -	4	STO -
5		5	
6	STO GND	6	STO GND

Pinout connector STO output signals

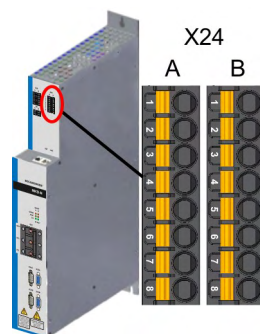

X24 A	Axis 1	X24 B	Axis 2
1...3	Digital In 1...3	1...3	Digital In 1...3
4	DCOM	4	DCOM
5...6	Digital Out	5...6	Digital Out
7	STO-Status +	7	STO-Status +
8	STO-Status -	8	STO-Status -

Wiring diagram STO Signals, example

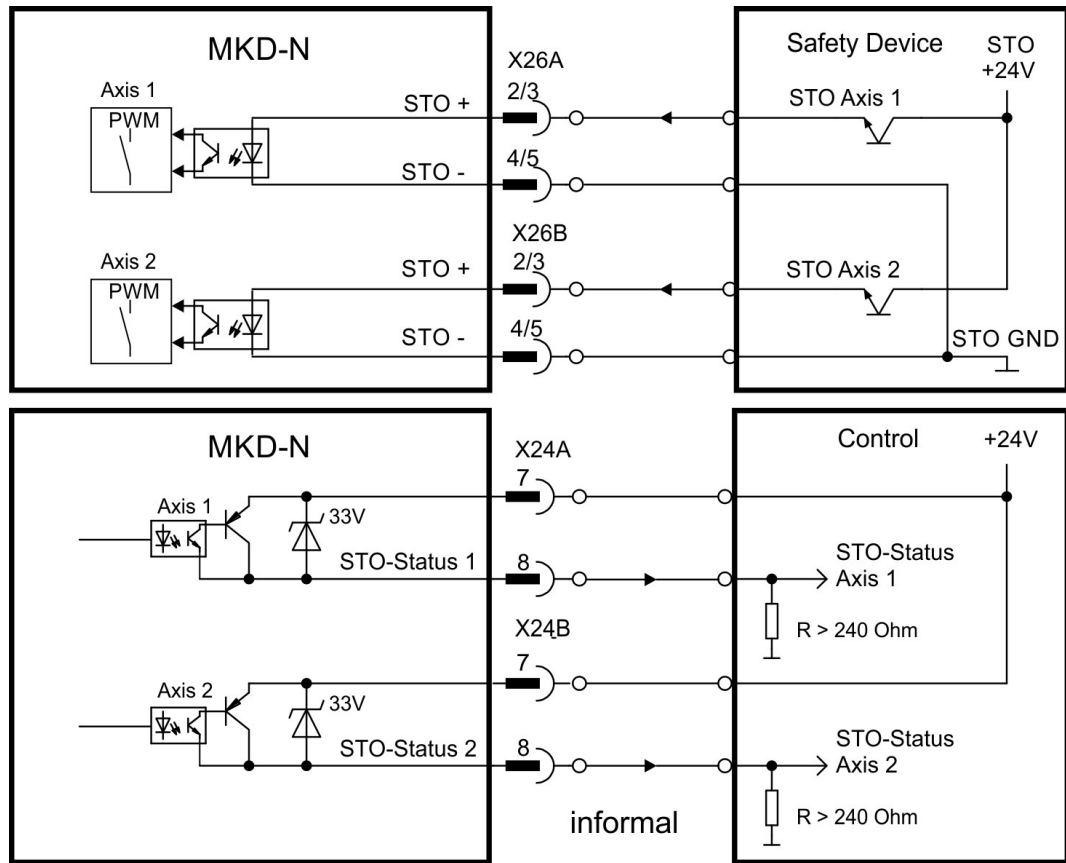

10.1.12.4 Local STO application example

The sample application below shows door guarding and emergency stop, controlled by a safety control to switch the local STO inputs of a dual-axis MKD-N drive module to SIL2, PLd. Both axes strings are switched independently.

NOTE Kollmorgen KSM modules cannot be used.

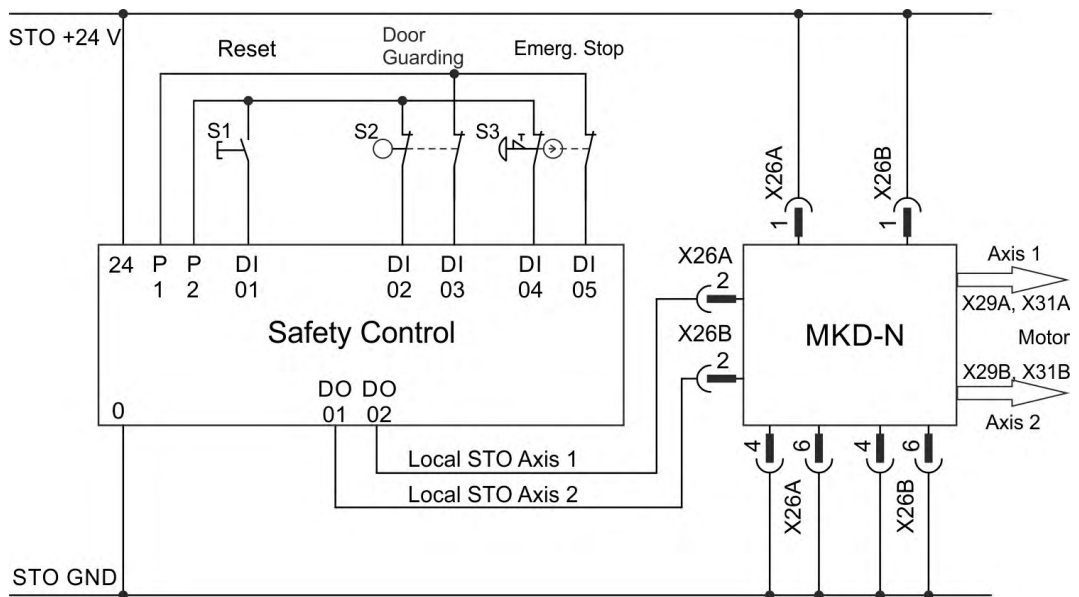

10.1.12.5 Functional description

The STO input releases the power output stage of the drive as long as a 24 V signal is applied to this input. When the local STO function (Safe Torque Off) is not needed, then the STO inputs must be connected directly to +24 VDC. The function is then bypassed and cannot be used.

NOTE

The global STO signals have no influence to this drive. The local STO input on the MKD-N has no influence to any global STO as well.

Local STO	String HW Enable	Local STO-Status	Safety acc. to SIL2	Drive can produce Torque
0 V	no	high	yes	no
0 V	yes	high	yes	no
+24 V	no	low	no	no
+24 V	yes	low	no	yes

When STO function is engaged during operation by separating input STO-Enable from 24 V, the connected motor slows down without control.

NOTE

Local STO-Status is high:

- during module boot (power up), or
- if the communication with one of the connected drive modules is lost, or
- if no drive is connected to the string, or
- if the local fieldbus doesn't work.

NOTICE

Use the following functional sequence when the STO function is used:

1. Brake the drive in a controlled manner (speed setpoint = 0 V).
2. When speed = 0 rpm, disable the drive (enable = 0 V).
3. If a suspended load is present, block the drive mechanically.
4. Activate the STO function.

NOTE

It is not possible to perform a controlled brake if the drive STO input is off.

If controlled braking prior to the use of the STO function is necessary, the drive must be braked first and the STO input must be separated from +24 V time-delayed.

10.1.12.6 Functional test

NOTICE

You must test the safe torque off function after initial start of the drive, after each interference into the wiring of the drive, or after exchange of one or several components of the drive. For dual axis modules you must test every axis separately.

First Method:

1. Stop the drive with setpoint 0 V. Keep drive enabled.
DANGER: Do not enter hazardous area!
2. Activate the local STO function for example by opening protective screen of the drive, (voltage at input STO = 0V).
3. The drive lose torque and slows down to zero speed without control.

Second Method:

1. Stop the drive with setpoint 0 V, disable drive.
2. Activate the STO function, for example, by opening protective screen (voltage at input STO = 0V)
3. The drive cannot be enabled.

10.1.13 Local STO on AKD-N

10.1.13.1 General information

The STO safety implementation on the AKD-N is certified. The safety circuit implementation used for the safety function "Safe Torque Off" in the drive is suited for SIL 2 according to IEC 62061 and PLd / CAT3 according to ISO 13849-1.

NOTE In case of using an AKD-N with option "DS" or "DT" (local STO input), the global STO signal will have not influence to this specific drive. The local STO input on the AKD-N and MKD-N have no influence to the global STO as well. The local AKD-N STO functionality is described in the AKD-N installation manual.

Refer to the *AKD-N Installation Manual* for detailed information.

10.2 Brake interruption contact

10.2.1 General information

NOTICE This functionality is not approved nor certified. Do not use these contacts in applications until further notice. The contacts must be jumpered.

Use cable with minimum 0.5 mm² cross section to jumper the contacts:

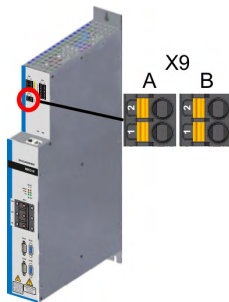

X9 A	Axis 1	X9 B	Axis 2
1	BrInt Out	1	BrInt Out
2	BrInt In	2	BrInt In

11 Setup

11.1 Important Notes	118
11.2 Guide to setup	119
11.3 Setup software WorkBench	121
11.4 Initial System Test	124

11.1 Important Notes

NOTE

Before testing and setup, the manufacturer of the machine must generate a risk assessment for the machine and take appropriate measures so that unforeseen movements cannot cause injury or damage to any person or property.

NOTICE

Only professional personnel with extensive knowledge in the fields of electrical engineering and drive technology are allowed to test and set up the drive.



DANGER Lethal Voltage!

There is a danger of serious personal injury or death by electrical shock. Lethal danger exists at live parts of the device.

- Built-in protection measures such as insulation or shielding may not be removed.
- Work on the electrical installation may only be performed by trained and qualified personnel, in compliance with the regulations for safety at work, and only with switched off mains supply, and secured against restart.



WARNING Automatic Start!

Risk of death or serious injury for humans working in the machine. The drive might restart automatically after power on, depending on the parameter setting. If parameter DRV.ENDEFAULT for one drive axis connected to one of the strings is set to 1,

- then place a warning sign to the machine (Warning: Automatic Restart at Power On) and
- ensure, that power on is not possible, while humans are in a dangerous zone of the machine.



CAUTION High Temperature!

Risk of minor burns. The heat sink of the AKD-N drives can reach temperatures up to 80°C in operation.

- Check the heat sink temperature before handling the drive.
- Wait until the heat sink has cooled down to 40°C before touching it.

NOTICE

If the MKD-C has been stored for more than 1 year, you must re-form the capacitors in the DC bus link circuit. Re-forming procedures are described in the Kollmorgen Developer Network ([Forming](#)).

NOTE

Additional information on setting up the equipment:

- Programming parameters and control loop behavior are described in the online help of the setup software.
- Kollmorgen can provide training courses for the drive upon request.

11.2 Guide to setup

Presumptions for the setup:

1. The drive is properly mounted (→ # 52).
2. Protective earth is connected (→ # 60).
3. Mains supply voltage is connected (→ # 81).
4. Auxiliary supply voltage is connected (→ # 82).
5. Safety Controller and PLC I/Os are connected (→ # 96).
6. String cables are connected (→ # 84).
7. EtherCAT Master is connected (→ # 103).
8. Service PC is connected (→ # 104).

11.2.1 System addresses

To tune and configure the MKD system, it is recommended to connect Workbench to the MKD system.

The MKD system can be accessed through two different physical communication channels:

1. Ethernet Service Port (X18) on the MKD-C unit (→ # 104)
2. EtherCAT Bus In port (X10) on the MKD-C unit (→ # 103)

Both communication channels allow a single point of connect to access the power supply (MKD-C) itself and all other drives (MKD-N's, AKD-Ns) that are connected to the MKD-C unit.

MAC Address

The unique MKD-C MAC address is pre-defined by the manufacturer (see nameplate). Every MKD-N or AKD-N drive axis has a unique MAC address as well.

IP Address

The MKD-C service port X18 supports Auto-IP, DHCP and static IP addressing.

Auto-IP:

All network devices that are connected receive a unique IP address in the range 169.254.x.y. To configure this, follow the next steps:

- PC with Auto-IP protocol active (without DHCP server or set static IP)
- Power up PC and connect it the MKD-C service port X18
- Set MKD-C rotary switch S1 to "0" (→ # 48).
- Power up the MKD system
- Wait for the PC network adapter has executed the Auto-IP protocol

Static IP:

The MKD-C IP address can be set with the S1 rotary switch (→ # 48).

WorkBench looks for IP address in the subnet to detect devices in the LAN and start communication.

All connected devices must have static IP addresses. Refer to the WorkBench Online Help for more information.

EtherCAT Node Address

The EtherCAT node address is assigned automatically by the EtherCAT master. Refer to WorkBench Online Help and EtherCAT manual for more information.

11.2.2 System Setup

Simple access to the system can be achieved by connecting a laptop or Service PC to the MKD-C service port X18 with a standard Ethernet Patch cable. However, not only the MKD-C can be accessed through this port, also all other drives that are connected to the MKD-C can be accessed through it. The MKD-C forwards the Ethernet packets to all other drives and returns the response packets. Every connected axis has a unique MAC address and can be viewed as standalone Ethernet device (client).

Example Auto-IP system

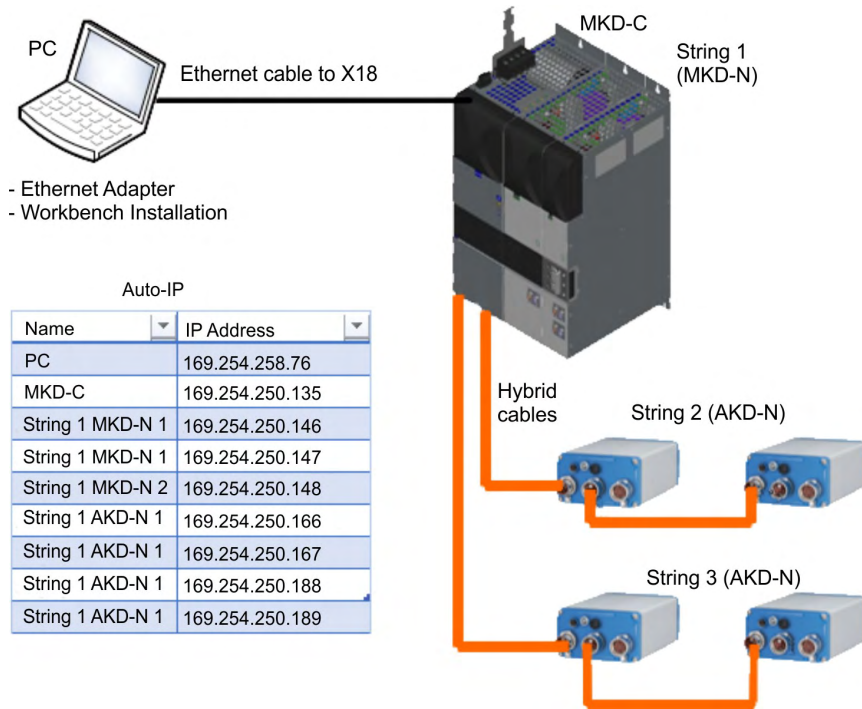

Refer to the WorkBench Online Help for more information.

11.3 Setup software WorkBench

This chapter describes the installation of the setup software WorkBench for MKD-C and MKD-N drives.

Kollmorgen offers training and familiarization courses on request.

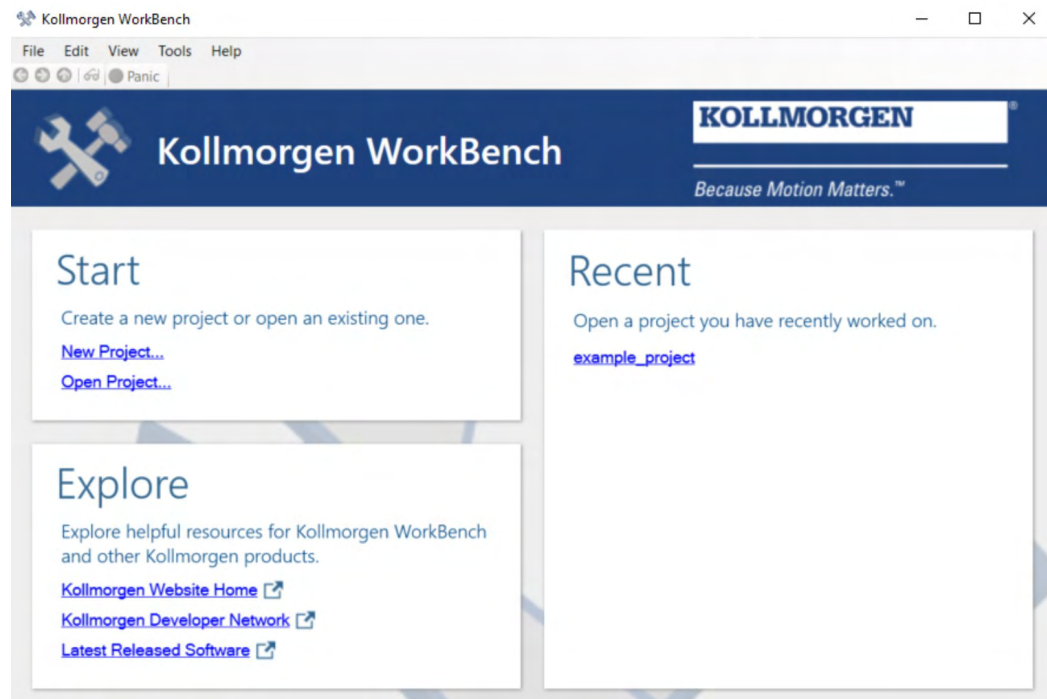

11.3.1 Use as directed

The setup software is intended to be used for altering and saving the operating parameters for the MKD and AKD series of products. The attached devices can be set up with the help of this software, and during this procedure the drive system can be controlled directly by the service functions.

Only professional personnel who have the relevant expertise (→ # 15) are permitted to carry out online parameter setting for a drive that is running. Sets of data that have been stored on data media are not safe against unintended alteration by other persons. Unexpected move could be the result if you use unchecked data. After loading a set of data you must therefore always check all parameters before enabling the drive.

11.3.2 Software description

Each device must be adapted to the requirements of your machine. For most applications, you can use a PC and WorkBench (the setup software) to set up the operating conditions and parameters. The PC is connected to the MKD-C by an Ethernet cable (→ # 104). The setup software provides the communication between the PC and every MKD-N or AKD-N drive connected to this MKD-C. You can find the setup software on the accompanying DVD and in the download area of the Kollmorgen website.

NOTE

With WorkBench every drive that is connected to the same MKD-C as the PC is visible and controllable.

You can select a drive out of the list, alter parameters, and instantly observe the effect on the drive, since there is a continuous (online) connection to the drive. You can also read important actual values from the selected drive, which are displayed on the monitor of the PC (oscilloscope functions).

You can save sets of data on data media (archiving) and load them into other MKD-C or use them for backup. You can also print out the data sets.

Most standard feedbacks (SFD, EnDAT, and BiSS) are plug and play compatible. Motor nameplate data is stored in the feedback device and read by the drive automatically at startup. Non-plug and play Kollmorgen motors are stored in WorkBench and can be loaded with one-click using the Motor screen in the WorkBench software.

An extensive online help with integrated description of all variables and functions supports you in each situation.

11.3.3 Hardware requirements

The Service interface (X18, RJ45) is connected to the Ethernet interface of the PC by an Ethernet cable (→ # 104).

Minimum requirements for the PC:

Processor: at least 1GHz

Operating system : Windows

RAM: 500MB

Graphics adapter : Windows compatible, color

Data Drives : hard disk with at least 500 MB free space, DVD drive

Interface : one free Ethernet Interface, or a Switch port, 100 Mbit/s

11.3.4 Operating systems

Windows 7 / 8 / 10

WorkBench works with Windows 7, 8 and Windows 10.

Unix, Linux

The functioning of the software has not been tested for Windows running with Unix or Linux.

11.3.5 Installation under Windows

The DVD includes an installation program for the setup software.

Installation

- Autostart function activated:
Insert the DVD into a free data drive. A window with the start screen opens. There you find a link to the setup software WorkBench. Click it and follow the instructions.
- Autostart function deactivated:
Insert the DVD into a free data drive. Click **Start** (task bar), then **Run**. Enter the program call: x:\index.htm (x = correct DVD drive letter).
Click **OK** and proceed as described above.

Connection to the Ethernet interface of the PC

- Connect the interface cable to an Ethernet interface on your PC or to a Switch and to the service interface X18 of the MKD-C (→ # 104).

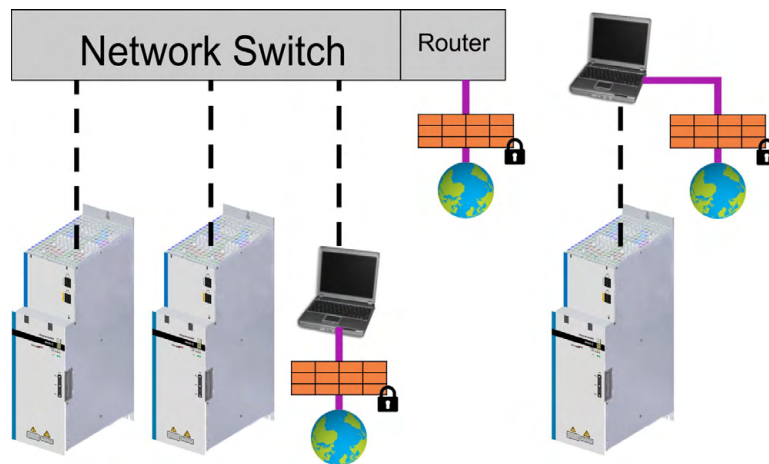

11.4 Initial System Test

1. Unpack the devices and accessories. Observe the safety instructions in the documentation.
2. Mount the devices and wire the system.
3. Validate mechanical and electrical installation.
4. Validate IP addresses
5. Make sure you have on hand the following information about the drive components:
 - rated mains supply voltage
 - motor type (motor data, if the motor type is not listed in the motor database)
 - feedback unit built into the motor (type, poles/lines/protocol)
 - moment of inertia of the load

11.4.1 Set system addresses

We suggest to use Auto-IP. All network devices that are connected receive a unique IP address in the range 169.254.x.y. WorkBench looks for IP address in the subnet to detect devices in the LAN and start communication. Refer to the WorkBench Online Help for information.

11.4.2 Confirm connections

Switch on 24 VDC logic power for the system (mains supply voltage is not needed for communications).

Confirm that the green link LED 1 on the MKD-C and on the PC are both illuminated.



While the PC is connecting, your status bar will show the following acquiring icon:

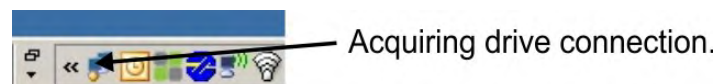

Wait for this icon to change to the limited functionality icon (this process can take up to one minute).

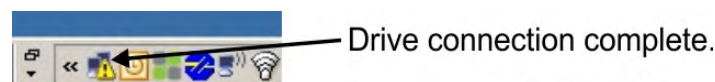

Although Windows displays this limited functionality icon for the drive connection, the PC can communicate fully with the drive. Using WorkBench, you can now configure the drive through this connection.

11.4.3 Install and start WorkBench

WorkBench is available from the DVD included with the drive and on the Kollmorgen Website: www.kollmorgen.com. Select the install file and follow the instructions given by the installer.

Once installation is complete, click the WorkBench icon to start the program.

11.4.4 Parameterize and enable the axes in WorkBench

Refer to the WorkBench Online Help for information.

12 Appendix

12.1	Fault and Warning Messages	126
12.2	Troubleshooting the MKD System	128
12.3	Accessories	129

12.1 Fault and Warning Messages

When a fault occurs, the MKD-C fault relay is opened, the output stage of the connected drive axes are switched off (motors lose all torque), or the load is dynamically braked. The specific behavior depends on the type of fault. The seven segment LED display shows the number of the fault that occurred. If a warning is issued prior to the fault, the warning is shown and has the same number as the associated fault. Warnings do not trip the power stages of the connected drive axes.

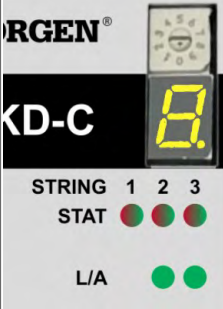
	Rotary Switch	MKD fault codes or warning codes are displayed constantly if present. Fault messages are coded with "F", warnings are coded with "n". The LED displays the fault or warning number as follows: F-1-0-1-[break] or n-1-0-1-[break]. The highest priority fault is displayed. Multiple faults may be present when a fault condition is occurring. Check the WorkBench Fault Screen or read the status of DRV.FAULTS through the controller or HMI for the entire list of faults.
	7 Segment Display	
Run/Error LEDs		
Link/Activity		

NOTICE

Eliminate errors and faults in compliance with work safety rules. Troubleshooting only by qualified and trained staff.

NOTE

More information about warnings and fault messages, causes, remedy and clearing faults can be found in the WorkBench online help.

Code	Message/Warning
F101	Firmware type mismatch.
F102	Resident firmware failed.
F103	Resident FPGA failed.
F104	Operational FPGA failed.
F105	Non-volatile memory stamp invalid.
F106	Non-volatile memory data (might occur when downloading firmware).
F125	Fieldbus synchronization frames lost.
F136	Firmware and FPGA versions are not compatible.
F201	Internal RAM failed.
F202	External RAM failed.
F203	Code Integrity failed.
F204	Control board EEPROM read failed.
F205	Control board EEPROM corrupted serial number stamp.
F206	Control board EEPROM corrupted serial number data.
F207	Control board EEPROM corrupted parameter stamp.
F208	Control board EEPROM corrupted parameter data.
F209	Power board EEPROM read failed.
F210	Power board EEPROM corrupted serial number stamp.
F212	Power board EEPROM corrupted serial number data.
F213	Power board EEPROM corrupted parameter stamp.
F214	Power board EEPROM corrupted parameter data.
F219	Control board EEPROM write failed.
F230	Power board EEPROM write failed.
F232	Power board EEPROM invalid data.
F234	Control over temperature sensor 1.

Code	Message/Warning
F235	Power over temperature sensor 1.
F236	Power over temperature sensor 2.
F237	Power over temperature sensor 3.
F238	Power over temperature sensor 4.
F240	Control under temperature sensor 1.
F241	Power under temperature sensor 1.
F242	Power under temperature sensor 2.
F243	Power under temperature sensor 3.
F246	Power under temperature sensor 4.
F501	Bus over voltage.
F503	Bus capacitor overloaded.
F519	Regen short circuit.
F521	Regen over power.
F523	Bus over voltage FPGA.
F531	Power stage fault.
F536	Standby power supply fault.
F537	Precharge fault.
F541	AC input phase 1 missing.
F542	AC input phase 2 missing.
F543	AC input phase 3 missing.
F545	String current over peak limit.
F546	String current over continuous limit.
F561	Too many nodes connected on string 2.
F562	Too many nodes connected on string 1.
F563	Too many nodes connected on string 3.
F564	Number of connected nodes on string 1 has decreased.
F565	Number of connected nodes on string 2 has decreased.
F567	Number of connected nodes on string 3 has decreased.
F568	String 1 current over peak limit.
F569	String 2 current over peak limit.
F571	String 3 current over peak limit.
F572	String 1 current over continuous limit.
F573	String 2 current over continuous limit.
F574	String 3 current over continuous limit.
F576	String 1 desaturated.
F578	String 2 desaturated.
F579	String 3 desaturated.
F580	String 1 over current.
F581	String 2 over current.
F582	String 3 over current.
F583	Rectifier desaturated.
F584	Bulk precharge over current.
F585	Bulk precharge desaturated.
F586	String precharge desaturated.
F621	Control board CRC fault.

Code	Message/Warning
F623	Power board CRC fault.
F624	Power board watchdog fault.
F625	Power board communication fault.
F626	Power board FPGA not configured.
F627	Control board watchdog fault.
F628	Front door packet not received on string 1.
F629	Front door packet not received on string 2.
F630	FPGA cyclic read fault.
F632	Front door packet not received on string 3.
F702	Fieldbus communication lost.
F706	Fieldbus cyclic setpoints missing.

12.2 Troubleshooting the MKD System

Drive problems occur for a variety of reasons, depending on the conditions in your application. The causes of faults in multi-axis systems can be very complex. If you cannot resolve a fault, Kollmorgen customer support can give you further assistance.

NOTICE

Eliminate errors and faults in compliance with work safety rules. Troubleshooting only by qualified and trained staff.

NOTE

Details on the removal of faults can be found in the WorkBench online help.

12.3 Accessories

12.3.1 Mains choke



DANGER High Voltage up to 480 V!

Risk of electric shock.

- Make sure that the cabinet is safely disconnected (for instance, with a lock-out and warning signs).
- Wait at least 5 minutes after disconnecting the drive from the main supply power before touching potentially live sections of the equipment (e.g. contacts) or undoing any connections.

NOTICE

Due to the high earth leakage currents induced by the system, you should observe the requirements of EN 61800-5-1 (e.g. fixed installation, $\geq 10 \text{ mm}^2$ or double protective earth) when carrying out mounting and installation work.

Mounting: 50 mm free space required above and below the device.

Connection diagram: see (→ # 81)

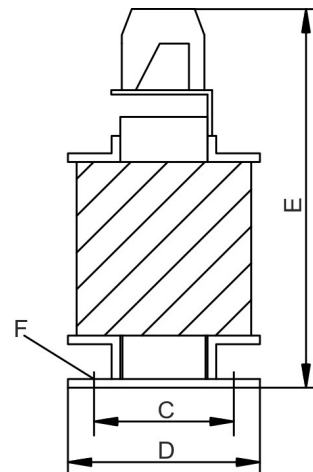
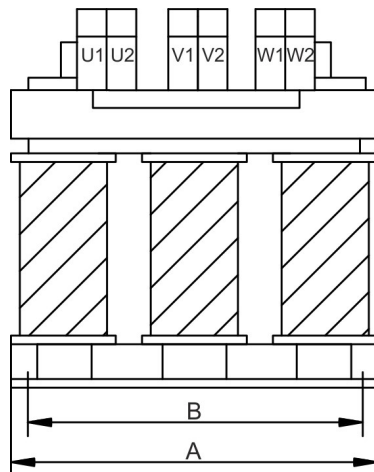
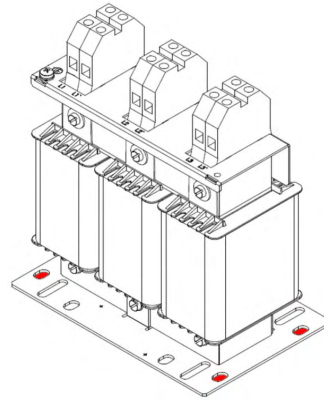
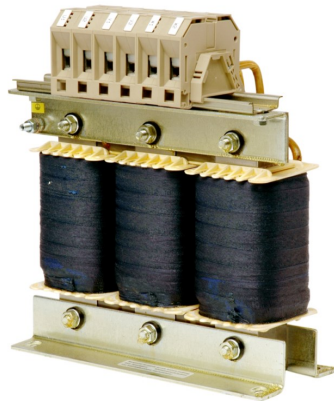

Technical Data

Type	Inductivity [mH]	Nominal Current [A]	uk [%]	A [mm]	B [mm]	C [mm]	D [mm]	E [mm]	F [mm]	Terminals [mm ²]	Weight [kg]
3L 0,5-63-4	0.47	63	4	185	170	77	122	215	8x12	16	9.65

12.3.2 Regen resistors

During braking with the aid of the motor, energy is fed back into the drive. This regenerative energy is dissipated as heat in the regen resistor (also called brake resistor). The regen resistor is switched on by the regen circuit. All resistors meet the requirements of CE directives and are UL-registered.

More information to the resistors are given on KDN page "[Brake Resistor](#)".

12.3.2.1 Important notes



⚠ DANGER High Voltage up to 900 V!

Risk of electric shock. Power terminals are capable of conducting hazardous voltage up to 10 minutes after the mains voltage has been disconnected.

- Before starting work on power terminals, check that the phase-to-earth and phase-to-phase voltages have de-energised.



⚠ WARNING High Temperature!

Risk of burns. The regen resistor surface temperature can exceed 250°C.

- Measure the temperature and wait until temperature dropped down below 40°C, before touching the resistor housing.

NOTICE

Inadequate levels of cooling air or incorrect installation can lead to overheating and destruction of the resistor and surrounding components.

- May only be installed in switchgear cabinets, comply with the permissible installation types and clearances (see dimensional drawing).
- Ensure there is unobstructed convection for cooling purposes.
- Use temperature-resistant materials in the vicinity of the resistor.
- The connection terminals must never be located within the flow range of the heated waste air.

The following requirements must be met to ensure the regen resistors work properly:

- Compliance with required installation clearances
- Compliance with permissible installation type
- Unhindered access of cooling air
- Unhindered diverting of warmed up air
- Rated data with maximum ambient temperature 40°C, in case of ambient temperature higher than 40°C, power must be reduced by 4% per 10K temperature rise
- Use fusing (e.g. FPS) to prevent the resistor from being overloaded (→ # 37).

Regen resistor	Device	Resistance [Ω]	Rated Power [W]	Max. Power [W]	Order code
BAS(U) 2000-10	MKD-C003007	10	2000	3200	DE-103874
BAS(U) 3000-10		10	3000	4800	DE-103875
BAS(U) 6000-10		10	6000	9600	DE-103876

12.3.2.2 Dimensions and Data



Protection class: IP20



WARNING High Temperature!

The surface temperature can exceed 250°C. Risk of burns and fire!

- Measure the temperature before touching.
- Use fusing (e.g. FPS) to prevent the resistor from being overloaded.

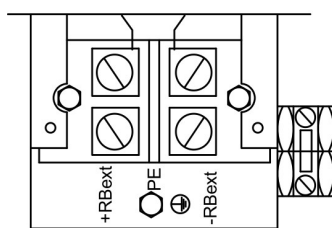
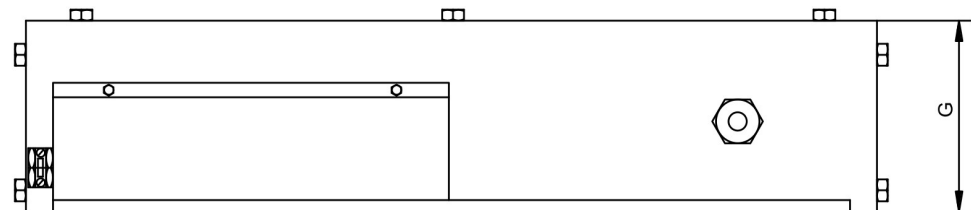
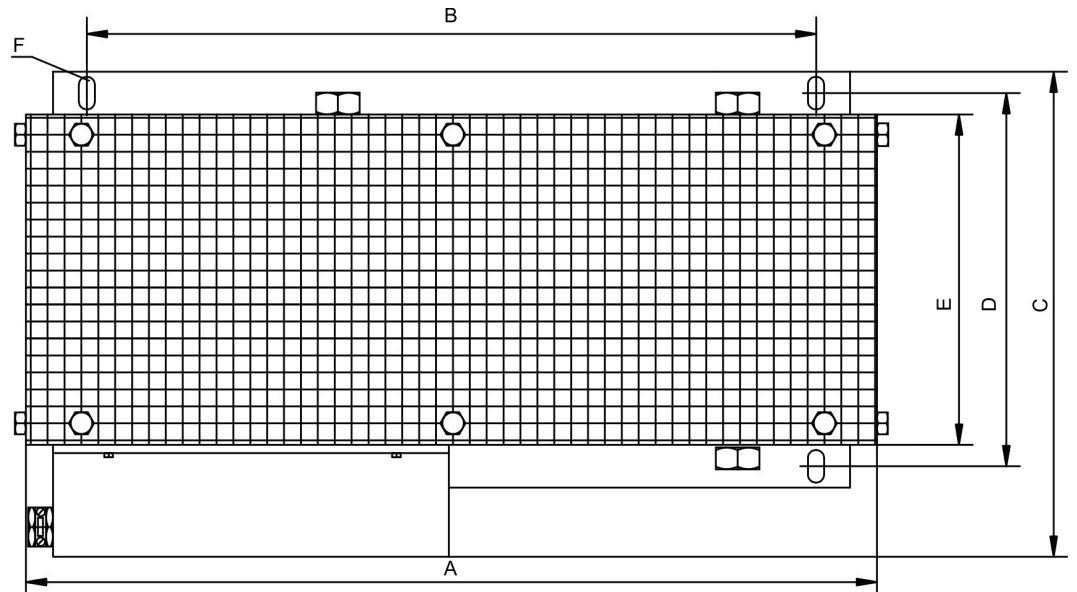

±10%, temperature drift approx. 1%
Cold approx. +8%, 320°C approx. -7%

Admissible floor mounting

Admissible wall mounting
Clamps down

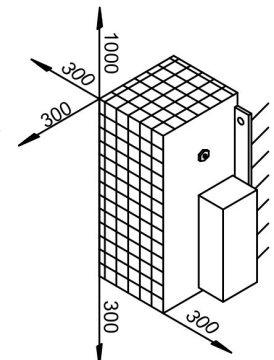
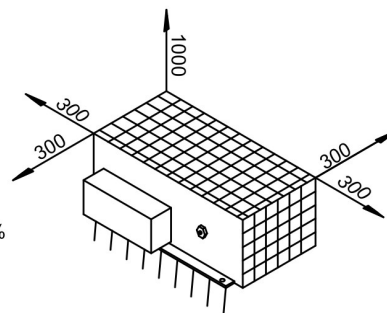

Other types of mounting are not admitted !

	R	Rated power	A	B	C	D	E	F	G	weight
	Ω	W	mm	mm	mm	mm	mm	mm	mm	Kg
BAS(U)2000-10	10	2000	490	380	255	170	150	Ø10,5	260	7
BAS(U)3000-10	10	3000	490	380	355	270	250	Ø10,5	260	8
BAS(U)6000-10	10	6000	490	380	455	370	350	Ø10,5	260	11

12.3.3 Cables

12.3.3.1 Overview

Quality: z= S (static), I (intermediate to 100 m/min, 1G), D (dynamic up to 300 m/min, 2.5G)

Order codes to be followed by length definition.

12.3.3.1.1 Hybrid String cables

Device	Description	Device	Order code
MKD-C	String cable	AKD-N	MKC-HYB-z-AKN
AKD-N	String cable	AKD-N	AKN-HYB-z-AKN

12.3.3.1.2 Hybrid Motor Cables

Drive	Description	Motor	Order code
MKD-N 6A/12A	Power, Brake, SFD3 or DSL, 1.5 mm ²	AKM1G	MKN-GE4-z-M23
MKD-N 6A/12A	Power, Brake, SFD3 or DSL, 2.5 mm ²	AKM1G	MKN-GE5-z-M23
MKD-N 24A	Power, Brake, SFD3 or DSL, 4 mm ²	AKM1G	MKH-GE6-z-M23
AKD-N	Power, Brake, SFD3 or DSL, 1.5 mm ²	AKM1G	CCJNA2-015
AKD-N	Power, Brake, SFD3 or DSL, 2.5 mm ²	AKM1G	CCJNA2-025

12.3.3.1.3 Motor Power Cables

Drive	Description	Motor	Order code
MKD-N 6A / 12A	Power, 1.5 mm ²	AKM1G	MKN-N15-z-M23
MKD-N 6A / 12A	Power, Brake, 1.5 mm ²	AKM1G	MKN-B15-z-M23
MKD-N 6A / 12A	Power, 2.5 mm ²	AKM1G	MKN-N25-z-M23
MKD-N 6A / 12A	Power, Brake, 2.5 mm ²	AKM1G	MKN-B25-z-M23
MKD-N 24A	Power, 4 mm ²	AKM1G	MKN-N40-z-M23
MKD-N 24A	Power, Brake, 4 mm ²	AKM1G	MKN-B40-z-M23
MKD-N 24A / 48A	Power, 4 mm ²	AKM1G	MKH-N40-z-M40
MKD-N 24A / 48A	Power, Brake, 4 mm ²	AKM1G	MKH-B40-z-M40
MKD-N 24A / 48A	Power, 6 mm ²	AKM1G	MKH-N60-z-M40
MKD-N 24A / 48A	Power, Brake, 6 mm ²	AKM1G	MKH-B60-z-M40
MKD-N 24A / 48A	Power, 10 mm ²	AKM1G	MKH-10N-z-M40
MKD-N 24A / 48A	Power, Brake, 10 mm ²	AKM1G	MKH-10B-z-M40
MKD-N 24A / 48A	Power, 16 mm ²	AKM1G	MKH-16N-z-M40
MKD-N 24A / 48A	Power, Brake, 16 mm ²	AKM1G	MKH-16B-z-M40
AKD-N	Power, 1.5 mm ²	AKM1G	CM0NA2-015
AKD-N	Power, Brake, 1.5 mm ²	AKM1G	CM1NA2-015
AKD-N	Power, 2.5 mm ²	AKM1G	CM0NA2-025
AKD-N	Power, Brake, 2.5 mm ²	AKM1G	CM1NA2-025

12.3.3.1.4 Motor Feedback Cables

Drive	Description	Motor	Order code
MKD-N	Enc.+Hall, Comcoder	AKM1G	AK7-AQB-z
MKD-N	EnDat 2.2, BiSS C	AKM1G	AK7-END-z
MKD-N	EnDat 2.1, BiSS B	AKM1G	AK7-END-z
MKD-N	SFD	AKM1G	AK7-SFD-z
AKD-N	Enc.+Hall, Comcoder	AKM1G	CFCNA2-002
AKD-N	EnDat 2.2, BiSS C	AKM1G	CFxNA2-002
AKD-N	EnDat 2.1, BiSS B	AKM1G	CFDNA2-002
AKD-N	SFD	AKM1G	CFSNA2-002

12.3.3.1.5 EtherCAT cables

Device	Description	Device	Order code
EtherCAT Master	Master cable	MKD-C X10	Standard, Cat.6
EtherCAT MKD-C X11	Module cable	MKD-N X27	Standard, Cat.6
EtherCAT MKD-N X28	Module cable	MKD-N X27	Standard, Cat.6
MKD-C X21A	Communication Adapter String 2	MKD-N X27	MKC-ETH-S-RJ4

-- / --

13 Index

A

Abbreviations	12
Accessories	
Cables	132
Mains choke	129
Regen Resistors	130
Address	
EtherCAT	119
IP	119
MAC	119
Ambient Conditions	38
Ambient temperature	38
Aux. supply 24V, interface	82

C

Cable and Wire Requirements	41
Cable Length Definition	43
Conformance	
CE	27
REACH	27
RoHS	27
Safety	27
UL, cUL	27
Connection Diagram	68
Connection Overview	64
Connector Assignments	64
Connectors	39

D

DC bus link, interface	83
DC Power String, interface	87
Decommission	24
Digital inputs	99
Disassemble	24
Disposal	25
Document Revisions	137
Dynamic Braking	44

E

Electrical Data	35
Emergency Off	18
Emergency Stop Function	18
ENABLE	99
Enclosure protection	38
EtherCAT	103

F

Fault messages	126
FAULT relay	101

Fieldbus String, interface	87
Functional Safety	105
Fusing	37

G

Global STO	109
Ground System	38
Grounding	55

H

Humidity	
in operation	38
Storage	23
Transport	23

I

I/O-Connection	96
Initial Drive Test	124
Inputs	
Basic Data	96
Digital	99
Enable	99
Programmable	99
STO	109
Installation	
Electrical	53
Mechanical	50
Software WorkBench	123
Installation, Setup, Normal Operation	24

L

Labels	21
Leakage current	17

M

Mains supply, interface	81
Maintenance	24
Mechanical Data	34
MKD Multiaxes System	33
Motor interface	89
Motor overload protection	89
Mounting position	38

N

Nameplate	30
Noise Emission	38

O

Outputs	
Basic Data	96
Relay	101

Transistor	101
P	
Package supplied	29
Packaging	23
Part number scheme	31
PC connection	104
Performance Data	34
Pollution level	38
Prohibited Use	
General	21
STO	106
Pushbutton B1	47
R	
Re-forming	23, 118
REACH	27
Regen circuit	44
Regen resistor, interface	88
Repair	25
Response Time	
STO	108
RoHS	27
S	
Safe Torque Off (STO)	109
Safety	
Functional Safety	105
Safety Instructions	
General	14
STO	105
Service Interface	104
Setup	118
Setup Software	121
Shielding	55
Shock-hazard protection	17
Site	50
Site altitude	38
Stacking Height	
Storage	23
Transport	23
Standards used	13
STO	109
STO Response Time	108
Stop Function	18
Storage	23
Supply networks	80
Symbols used	11
System Topology	61
T	
Temperature	
in operation	38

Storage	23
Transport	23
Tightening torques, connectors	40
Transport	23
Trouble Shooting	128
U	
Use as directed	
General	20
STO	106
WorkBench Setup Software	121
V	
Ventilation	38
Mechanical Installation	50
Vibrations	38
W	
Warnings	126
Wiring	57
WorkBench	121
Hardware requirements	122
Installation	123
Operating systems	122

14 Record of Document Revisions

Revision	Remarks
A, 01/2019	First edition

About KOLLMORGEN

Kollmorgen is a leading provider of motion systems and components for machine builders. Through world-class knowledge in motion, industry-leading quality and deep expertise in linking and integrating standard and custom products, Kollmorgen delivers breakthrough solutions that are unmatched in performance, reliability and ease-of-use, giving machine builders an irrefutable marketplace advantage.



Join the [Kollmorgen Developer Network](#) for product support. Ask the community questions, search the knowledge base for answers, get downloads, and suggest improvements.

North America

KOLLMORGEN

201 West Rock Road
Radford, VA 24141, USA

Web: www.kollmorgen.com
Mail: support@kollmorgen.com
Tel.: +1 - 540 - 633 - 3545
Fax: +1 - 540 - 639 - 4162

Europa

KOLLMORGEN Europe GmbH

Pempelfurtstr. 1
40880 Ratingen, Germany

Web: www.kollmorgen.com
Mail: technik@kollmorgen.com
Tel.: +49 - 2102 - 9394 - 0
Fax: +49 - 2102 - 9394 - 3155

South America

KOLLMORGEN

Avenida João Paulo Ablas, 2970
Jardim da Glória, Cotia – SP
CEP 06711-250, Brazil

Web: www.kollmorgen.com
Mail: contato@kollmorgen.com
Tel.: +55 11 4615-6300

China and SEA

KOLLMORGEN

Floor 4, Building 9, No. 518,
North Fuquan Road, Changning District,
Shanghai 200335, China

Web: www.kollmorgen.cn
Mail: sales.china@kollmorgen.com
Tel.: +86 - 400 661 2802

KOLLMORGEN[®]

Because Motion Matters™