

MMC™

Hardware Manual

Part Number M.1300.7165

Version 12.0

Giddings & Lewis

Giddings & Lewis
Controls, Measurement and Sensing

NOTE

Progress is an on-going commitment at Giddings & Lewis. We continually strive to offer the most advanced products in the industry; therefore, information in this document is subject to change without notice. The illustrations and specifications are not binding in detail. Giddings & Lewis shall not be liable for any technical or editorial omissions occurring in this document, nor for any consequential or incidental damages resulting from the use of this document.

DO NOT ATTEMPT to use any Giddings & Lewis product until the use of such product is completely understood. It is the responsibility of the user to make certain proper operation practices are understood. Giddings & Lewis products should be used only by qualified personnel and for the express purpose for which said products were designed.

Should information not covered in this document be required, contact the Customer Service Department, Giddings & Lewis, 660 South Military Road, P.O. Box 1658, Fond du Lac, WI 54936-1658. Giddings & Lewis can be reached by telephone at (920) 921-7100.

M.1300.7165

Release 0201
© 1999, 2000, 2001 Giddings & Lewis, LLC

Belden® is a registered trademark of Cooper Industries, Inc.
IBM is a registered trademark of International Business Machines Corp.
Windows 95, 98, NT, Microsoft, and MS-DOS are registered trademarks of Microsoft Corporation.
MOD HUB is a trademark of Contemporary Control Systems, Inc.
ARCNET® is a registered trademark of Datapoint Corporation.
ST is a trademark of AT&T Bell Labs.
Temposonics™ is a trademark of Contemporary Control Systems, Inc.
DeviceNet™ is a trademark of Open DeviceNet™ Vendor Association, Inc.
Pentium and PentiumPro are trademarks of Intel Corporation.
PiC900, PiCPro, MMC, PiCServoPro, PiCTune, PiCProfile, LDO Merge, PiCMicroTerm and PiC Programming Pendant are trademarks of Giddings & Lewis, LLC.

Table of Contents: MMC Hardware Manual

| | | |
|----------|-------------------------------------------------------------------------|-----------|
| 1 | Safety Precautions | 5 |
| 1.1 | System Safety | 5 |
| 1.1.1 | User Responsibility..... | 5 |
| 1.1.2 | Safety Instructions | 5 |
| 1.2 | Safety Signs | 6 |
| 1.3 | Warning Labels | 7 |
| 1.4 | Safety First | 8 |
| 1.5 | Safety Inspection | 8 |
| 1.5.1 | Before Starting Operations | 8 |
| 1.6 | After Shutdown | 8 |
| 1.7 | Operating Safely | 8 |
| 1.8 | Electrical Service & Maintenance Safety | 9 |
| 1.9 | Safe Cleaning Practices | 10 |
| 2 | Introduction | 11 |
| 2.1 | Overview | 11 |
| 2.2 | Major Components | 11 |
| 2.2.1 | Machine Control Board | 13 |
| 2.2.2 | Motion Control Board | 13 |
| 2.2.2.1 | Analog Servo board | 13 |
| 2.2.2.2 | SERCOS board | 14 |
| 2.2.3 | Option Modules | 15 |
| 3 | Mounting the MMC Control | 17 |
| 4 | Adding an Option Module to the MMC Control | 19 |
| 5 | Dimensions and Mounting of MMC with Option Module Attached | 21 |
| 6 | System Power and Environment Requirements | 23 |
| 6.1 | General Power and Environment Requirements | 23 |
| 6.2 | Control Cabinet Specifications | 23 |
| 6.3 | Power Distribution Diagram | 24 |
| 6.4 | Notes for 24V Power Supply and MMC | 25 |
| 6.5 | Grounding the System | 28 |
| 6.6 | Controlling Heat Within the System | 29 |
| 6.7 | Handling an MMC | 30 |
| 7 | System Wiring Guidelines | 31 |
| 7.1 | Recommended Signal Separation | 31 |
| 7.2 | Differential Devices for Analog and Encoder Signals | 33 |
| 8 | Starting an Operation | 35 |
| 8.1 | Connecting the MMC to the Application | 35 |
| 8.2 | Troubleshooting | 36 |
| 8.3 | Diagnostics | 37 |
| 8.3.1 | Power-On Diagnostics | 37 |

| | | |
|------------|----------------------------------------------------------------------|--------------|
| 8.3.1.1 | Power LED | 37 |
| 8.3.1.2 | Scan LED | 37 |
| 8.3.1.3 | Diagnostic LEDs | 37 |
| 8.3.2 | Run-Time Diagnostics | 38 |
| 9 | MMC Connections to External Devices for Machine Control | 39 |
| 9.1 | PiCPro Port | 39 |
| 9.2 | Block I/O Port | 40 |
| 9.3 | User Port | 41 |
| 9.4 | General I/O Port | 42 |
| 9.5 | Power Connection | 45 |
| 10 | MMC Analog Servo Connections for Motion Control | 47 |
| 10.1 | Axis Connectors | 47 |
| 10.2 | Auxiliary I/O Connector | 52 |
| 11 | MMC SERCOS Connections for Motion Control | 57 |
| 11.1 | SERCOS Receive and Transmit Ports | 57 |
| 11.2 | Serial (Loader) Port | 58 |
| 12 | Basic MMC Theory of Operation | 59 |
| 12.1 | Machine Control Board Operation | 59 |
| 12.2 | LEDs | 60 |
| 12.3 | Diagnostic Error Codes | 61 |
| 12.4 | MMC Machine Control | 62 |
| 12.5 | Application in Flash | 62 |
| 12.6 | General I/O Output Operation | 63 |
| 12.7 | Protecting from an Inductive Load | 63 |
| 12.8 | DC Output Theory of Operation (Axis Connector) | 64 |
| 12.9 | DC Input Operation (Axis, AUX, General Connectors) | 65 |
| 13 | Analog Servo Control Operation | 67 |
| 13.1 | Analog Output Theory of Operation (Axis Connectors) | 68 |
| 13.2 | Encoder Theory of Operation (Axis and AUX Connectors) | 68 |
| 13.3 | Analog Input Operation (AUX Connector) | 70 |
| 14 | MMC SERCOS Control Operation | 71 |
| 15 | Replacing the MMC Battery | 73 |
| 16 | Specifications | 75 |
| A.1 | MMC Ethernet TCP/IP Module | A.1-1 |
| 1 | Introduction | A.1-1 |
| 2 | Connections | A.1-2 |
| 2.1 | The Ethernet Port | A.1-4 |
| 2.2 | The RS232 COMM Ports | A.1-4 |
| 3 | LEDs | A.1-5 |
| 4 | Firmware Update | A.1-5 |
| 5 | Theory of operation | A.1-6 |
| 6 | Specifications Table | A.1-7 |
| 7 | Useful Internet Links | A.1-8 |

| | |
|--------------------------------------------------------------------------------------|--------------|
| B.1 - MMC DeviceNet Module | B.1-1 |
| 1 Introduction | B.1-1 |
| 2 Connections | B.1-2 |
| 2.1 The DeviceNet Port | B.1-3 |
| 2.2 The Configuration (RS232) Port | B.1-3 |
| 3 LEDs | B.1-4 |
| 4 Theory of Operation | B.1-5 |
| 5 Specifications | B.1-6 |
| C.1 - Breakout Boxes, Centurion Connector Cables and Flying Lead Cables C.1-1 | C.1-1 |
| 1 Breakout Boxes and Cables | C.1-3 |
| 1.1 Breakout Box and Cables for Axis Connector | C.1-3 |
| 1.1.1 Breakout Box for Axis Connector | C.1-4 |
| 1.1.2 Cable - Breakout Box to MMC Axis Connector | C.1-5 |
| 1.2 Breakout Box and Cables for Auxiliary I/O Connector | C.1-6 |
| 1.2.1 Breakout Box for AUX I/O Connector | C.1-6 |
| 1.2.2 Auxiliary I/O Connector Breakout Box with Encoder Isolators | C.1-9 |
| 1.2.3 Cable - Breakout Box to AUX I/O Connector | C.1-12 |
| 1.3 Breakout Box and Cables for Block I/O Connector | C.1-15 |
| 1.3.1 Block I/O Connector Breakout Box | C.1-15 |
| 1.3.2 Cable - Breakout Box to Block I/O Connector | C.1-17 |
| 1.4 Breakout Box and Cables for User Port Connector..... | C.1-18 |
| 1.4.1 User Port Connector Breakout Box | C.1-18 |
| 1.4.2 Cable - Breakout Box to USER PORT Connector | C.1-20 |
| 1.5 Breakout Box and Cables for General I/O Connector | C.1-21 |
| 1.5.1 Breakout Box for GEN I/O Connector | C.1-21 |
| 1.5.2 Cable - GEN I/O Connector to Breakout Box | C.1-23 |
| 2 Cables from Centurion Drives to MMC Axis Connector | C.1-25 |
| 2.1 Cable - DSM J1 Connector to MMC Axis Connector..... | C.1-25 |
| 2.2 Cable - MicroDSM J1 to MMC Axis Connector | C.1-27 |
| 3 Flying Lead Cables to MMC Control | C.1-29 |
| 3.1 Flying Lead Cable to MMC Axis Connector | C.1-29 |
| 3.2 Flying Lead Cable to MMC AUX I/O Connector | C.1-30 |
| 3.3 Flying Lead Cable to MMC BLK I/O Connector..... | C.1-33 |
| 3.4 Flying Lead Cable to MMC USER PORT Connector | C.1-34 |
| 3.5 Flying Lead Cable to MMC GEN I/O Connector | C.1-35 |
| D.1 - MMC Profibus Module | D.1-1 |
| 1 Introduction | D.1-1 |
| 2 Connections | D.1-2 |
| 2.1 The Profibus Port..... | D.1-3 |
| 2.2 The Configuration (RS232) Port | D.1-3 |
| 3 LEDs | D.1-4 |
| 4 Theory of Operation | D.1-5 |
| 5 Specifications | D.1-6 |

| | |
|----------------------------------------------------------------------|--------------|
| E.1 - CE and EMC Guidelines | E.1-1 |
| 1 Background on EMC (Electromagnetic Compatibility) Compliance | E.1-1 |
| 2 Background on Low Voltage Compliance | E.1-1 |
| 3 RFI Emission and Immunity | E.1-2 |
| 4 Classes of EMC Operating Environments | E.1-3 |
| 5 Conformance with the EMC Directive | E.1-4 |
| 6 Conformance With the Low Voltage Directive | E.1-4 |
| 7 Changes to the PiC Products | E.1-4 |
| 7.1 Changes Affecting the User..... | E.1-5 |
| 8 Using EMC and Non-EMC Modules | E.1-8 |
| 9 Declarations of Conformity | E.1-9 |
| Index | IND-1 |

1 Safety Precautions

READ AND UNDERSTAND THIS SECTION IN ITS ENTIRETY BEFORE UNDERTAKING INSTALLATION OR ADJUSTMENT OF MMC CONTROL EQUIPMENT

The advice contained in this section will help users to operate and maintain the equipment in a safe manner at all times.

PLEASE REMEMBER THAT SAFETY IS EVERYONE'S RESPONSIBILITY

1.1 System Safety

The basic rules of safety set forth in this section are intended as a guide for the safe operation of equipment. This general safety information, along with explicit service, maintenance and operational materials, make up the complete instruction set. All personnel who operate, service or are involved with this equipment in any way should become totally familiar with this information prior to operating.

1.1.1 User Responsibility

It is the responsibility of the user to ensure that the procedures set forth here are followed and, should any major deviation or change in use from the original specifications be required, appropriate procedures should be established for the continued safe operation of the system. It is strongly recommended that you contact your OEM to ensure that the system can be safely converted for its new use and continue to operate in a safe manner.

1.1.2 Safety Instructions

1. Do not operate your equipment with safety devices bypassed or doors removed.
2. Only qualified personnel should operate the equipment.
3. Never perform service or maintenance while automatic control sequences are in operation.
4. To avoid shock or serious injury, only qualified personnel should perform maintenance on the system.

5. **ATTENTION - DANGER TO LIFE**
Do not touch the main power supply fuses or any components internal to the power modules while the main power supply switch is ON. Note that when the main power switch is OFF, the incoming supply cable may be live.
6. **GROUNDING (Protective Earth)**
The equipment must be grounded (connected to the protective earth connection) according to OEM recommendations and to the latest local regulations for electrical safety. The grounding (protective earth) conductor must not be interrupted inside or outside the equipment enclosures. The wire used for equipment grounding (connection to protective earth) should be green with a yellow stripe.
7. If there is any doubt at all as to the safety of the equipment, you should set the main power switch to OFF and contact your OEM for advice.

1.2 Safety Signs

The purpose of a system of safety signs is to draw attention to objects and situations which could affect personal or plant safety. It should be noted that the use of safety signs does not replace the need for appropriate accident prevention measures. Always read and follow the instructions based upon the level of hazard or potential danger.

1.3 Warning Labels

Hazard warning

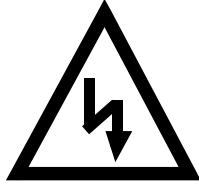

Danger Electric
Shock Risk

When you see this safety sign on a system, it gives a warning of a hazard or possibility of a hazard existing. The type of warning is given by the pictorial representation on the sign plus text if used.

The safety color is black on a yellow background with a black symbol. To ignore such a caution could lead to severe injury or death arising from an unsafe practice. If voltage levels are included in the text they must indicate the maximum level of the hazard in normal or fault condition.

Danger, Warning, or Caution warning



Symbol plus DANGER, WARNING or CAUTION: These notices provide information intended to prevent potential personal injury and equipment damage.

Hot Surface warning



Hot Surface

1.4 Safety First

Giddings & Lewis equipment is designed and manufactured with consideration and care to generally accepted safety standards. However, the proper and safe performance of the equipment depends upon the use of sound and prudent operating, maintenance and servicing procedures by trained personnel under adequate supervision.

For your protection, and the protection of others, learn and always follow these safety rules. Observe warnings on machines and act accordingly. Form safe working habits by reading the rules and abiding by them. Keep these safety rules handy and review them from time to time to refresh your understanding of them.

1.5 Safety Inspection

1.5.1 Before Starting Operations

1. Ensure that all guards and safety devices are installed and operative and all doors which carry warning labels are closed and locked.
2. Ensure that all personnel are clear of those areas indicated as potentially hazardous.
3. Remove (from the operating zone) any materials, tools or other objects that could cause injury to personnel or damage the system.
4. Make sure that the control system is in an operational condition.
5. Make certain that all indicating lights, horns, pressure gauges or other safety devices or indicators are in working order.

1.6 After Shutdown

Make certain all controlled equipment in the plant is safe and the associated electrical, pneumatic or hydraulic power is turned off. It is permissible for the control equipment contained in enclosures to remain energized provided this does not conflict with the safety instructions found in this section.

1.7 Operating Safely

1. Do not operate the control system until you read and understand the operating instructions and become thoroughly familiar with the system and the controls.
2. Never operate the control system while a safety device or guard is removed or disconnected

3. Where access to the control system is permitted for manual operation, only those doors which provide that access should be unlocked. They should be locked immediately after the particular operation is completed.
4. Never remove warnings that are displayed on the equipment. Torn or worn labels should be replaced.
5. Do not start the control system until all personnel in the area have been warned.
6. Never sit or stand on anything that might cause you to fall onto the control equipment or its peripheral equipment.
7. Horseplay around the control system and its associated equipment is dangerous and should be prohibited.
8. Know the emergency stop procedure for the system.
9. For maximum protection when carrying out major servicing requiring the system to be powered down, the power source should be locked using a lock for which only you have the key. This prevents anyone from accidentally turning on the power while you are servicing the equipment.
10. Never operate the equipment outside specification limits.
11. Keep alert and observe indicator lights, system messages and warnings that are displayed on the system.
12. Do not operate faulty or damaged equipment. Make certain proper service and maintenance procedures have been performed.

1.8 Electrical Service & Maintenance Safety

1. **ALL ELECTRICAL OR ELECTRONIC MAINTENANCE AND SERVICE SHOULD BE PERFORMED BY TRAINED AND AUTHORIZED PERSONNEL ONLY.**
2. It should be assumed at all times that the POWER is ON and all conditions treated as live. This practice assures a cautious approach which may prevent accident or injury.
3. To remove power:
**LOCK THE MAIN SWITCH IN THE OPEN POSITION.
USE A LOCK TO WHICH ONLY YOU HAVE THE KEY.**
4. Make sure the circuit is safe by using the proper test equipment. Check test equipment regularly
5. Capacitors take time to discharge. Care should be taken in manual discharging of capacitors

6. There may be circumstances where troubleshooting on live equipment is required. Under such conditions, special precautions must be taken:
 - Make sure your tools and body are clear of the areas of equipment which may be live.
 - Extra safety measures should be taken in damp areas.
 - Be alert and avoid any outside distractions.
 - Make certain another qualified person is in attendance.
7. Before applying power to any equipment, make certain that all personnel are clear of associated equipment.
8. Control panel doors should be unlocked only when checking out electrical equipment or wiring. On completion, close and lock panel doors.
9. All covers on junction panels should be fastened closed before leaving any job.
10. Never operate any controls while others are performing maintenance on the system.
11. Do not bypass a safety device.
12. Always use the proper tool for the job.
13. Replace the main supply fuses only when electrical power is OFF (locked out).

1.9 Safe Cleaning Practices

1. Do not use toxic or flammable solvents to clean control system hardware.
2. Turn off electrical power (lock out) before cleaning control system assemblies.
3. Keep electrical panel covers closed and power off when cleaning an enclosure.
4. Always clean up spills around the equipment immediately after they occur.
5. Never attempt to clean a control system while it is operating.
6. Never use water to clean control equipment unless you are certain that the equipment has been certified as sealed against water ingress. Water is a very good conductor of electricity and the single largest cause of death by electrocution.

2 Introduction

This document contains information for the MMC hardware. Block I/O information can be found in the PiC900 Hardware Manual. Software information can be found in the PiCPro Software Manual, the Function/Function Block Reference Guide, ASFB Manuals or on-line.

2.1 Overview

The MMC Control offers a complete solution to both machine and motion control in a stand-alone unit. The MMC family includes these models:

- MMC-A2 (2 1/2 axis analog servo control)
- MMC-A4 (4 1/2 axis analog servo control)
- MMC-S8 (8 axis SERCOS control)

The PiCPro for Windows programming tool used with the PiC family of controls is also used to program the MMC. The built-in I/O [28 inputs (24 VDC) and 16 outputs (24 VDC)] can be expanded using Giddings & Lewis serially distributed block I/O. There are also eight (four) low current DC and four (two) DC inputs on the Axis connectors of the MMC-A4 and MMC-A2.

Field-installable options for the MMC include an Ethernet TCP/IP interface and a DeviceNet™ master interface.

2.2 Major Components

The major components of an MMC Control include a Machine Control board and a Motion Control board contained within a metal enclosure.

Related external connections for the boards are located on the face of the enclosure.

Add-on communications modules are also available to connect to the MMC Control.

Figure 1: The MMC Control Units

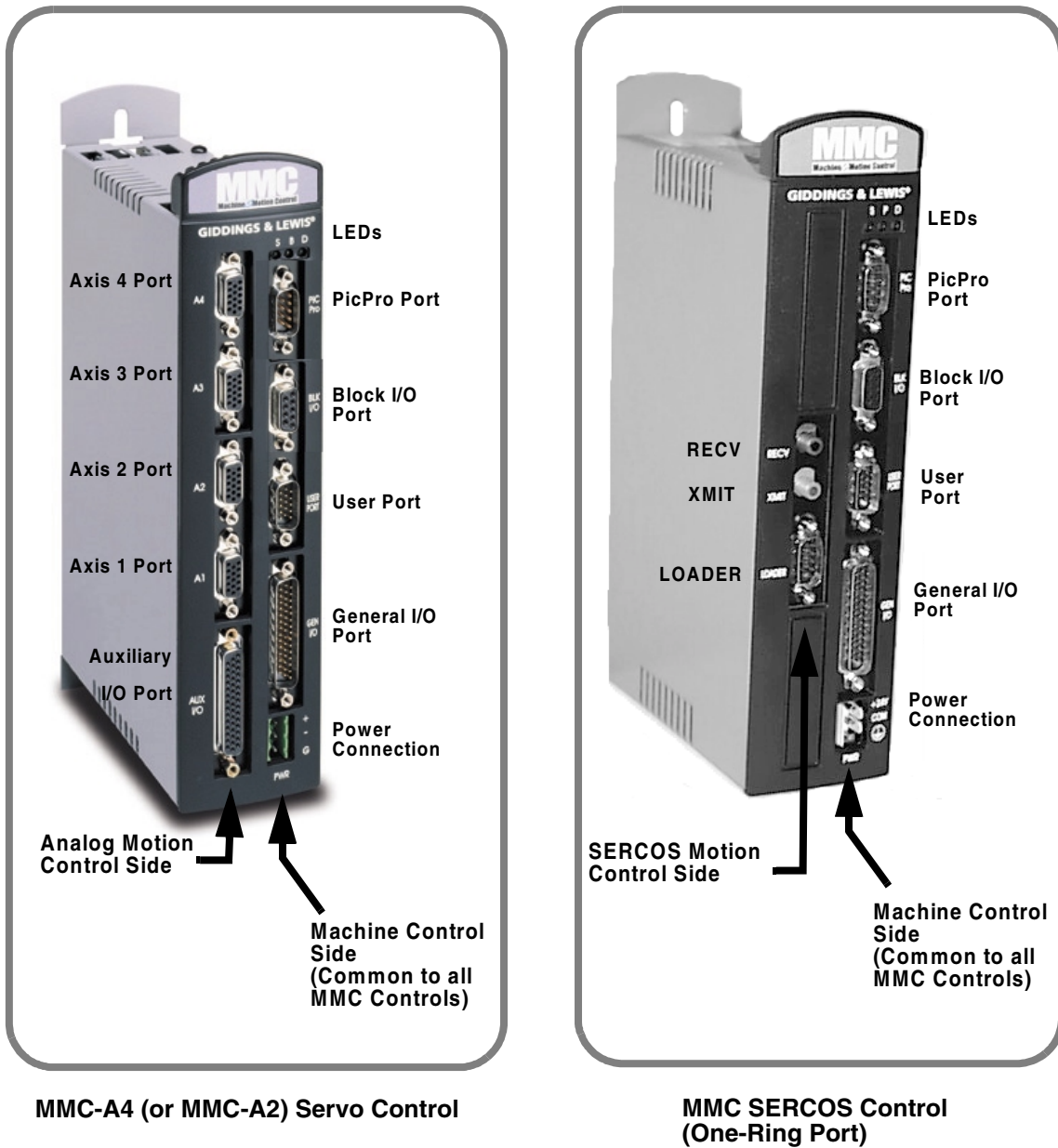

2.2.1 Machine Control Board

A Machine Control Board and its related external connections are located on the right side of the control. The Machine Control Board contains the CPU. Ladder logic programming is used for machine control. This board also provides the PiCPro serial interface port, block I/O interface port, user serial interface port and a general I/O port consisting of 16 DC outputs and 16 DC inputs

| Available I/O | 2 1/2 Axis | 4 1/2 Axis |
|-------------------------|------------|------------|
| GEN I/O Port DC Inputs | 16 | 16 |
| GEN I/O Port DC Outputs | 16 | 16 |

2.2.2 Motion Control Board

A Motion Control Board and its related external connections are located on the left side of the control. The motion control side of the MMC unit can be either an Analog Servo board or a SERCOS board.

2.2.2.1 Analog Servo board

The Analog Servo board provides conventional analog/digital interfacing for two or four drives.

The typical signals needed to interface to an analog drive are provided by the analog servo module. The drive command is in the form of an analog voltage ($\pm 10V$). Feedback is accepted from quadrature type encoders with RS422 style differential outputs. Digital I/O (+24 VDC) is used for drive signals enable, reset, and fault.

The analog servo board is offered in both 2 1/2 and 4 1/2 axis configurations. An axis is considered to be an analog output with a corresponding encoder input. In each configuration shown in the following table, note that there is an extra encoder input. This is referred to as a half axis.

| Available I/O | 2 1/2 Axis | 4 1/2 Axis |
|------------------------|-------------------|-------------------|
| Analog Inputs | 1 | 1 |
| Analog Outputs | 2 | 4 |
| Encoder Inputs | 3 | 5 |
| Axis DC Inputs | 2 | 4 |
| Axis DC Outputs | 4 | 8 |
| Axis Fast DC Inputs | 3 | 5 |
| AUX I/O Port DC Inputs | 6 | 12 |

2.2.2.2 SERCOS board

The SERCOS Motion Control board provides a fiber optic input and output for one SERCOS ring. There is also a serial port for field upgrades of the board processor's FLASH memory.

2.2.3 Option Modules

Optional communications modules provide special functions such as an Ethernet or DeviceNet interface. Figure 2 depicts an option module connected to an MMC Control.

Figure 2: Option Module Connected to MMC Control



NOTES

3 Mounting the MMC Control

Mount the unit to your cabinet using the mounting slots on the MMC. The MMC unit may be mounted vertically or horizontally. The recommended size of mounting hardware is #10 bolts with #10 star washers (to ensure proper ground connection) as shown in Figure 3

Figure 3: MMC Mounting Dimensions

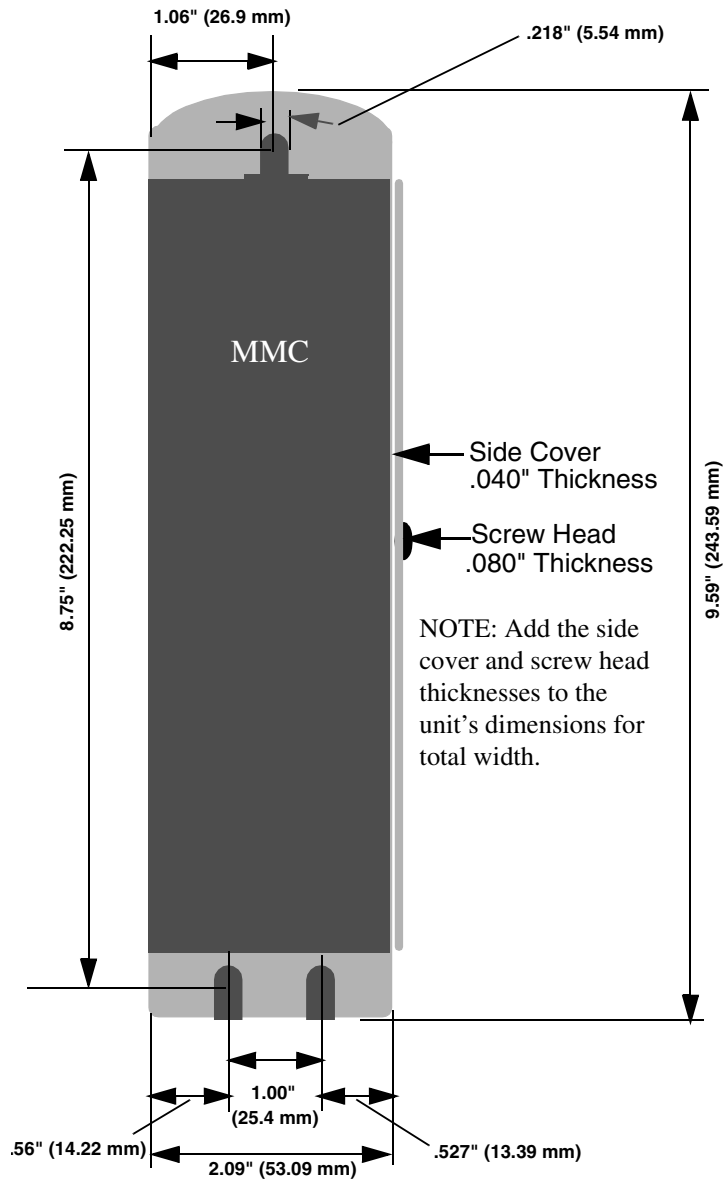

NOTES

4 Adding an Option Module to the MMC Control

Option modules are shipped with a 50-pin square post connector and screws needed to attach the module to the MMC. Follow the procedure below to add an option module to the MMC. Procedures are the same for the MMC A-4 Servo Control, MMC A-4 Servo Control and the MMC SERCOS Control Unit.

1. Place the MMC and the option module on a static free surface. Ground yourself using a properly grounded wrist strap before you begin. These are standard precautions before handling any electronic components.
2. Remove the five screws securing the MMC cover using a #1 Phillips screwdriver and set them aside. There are two screws on the top, two screws on the bottom, and one screw on the side of the module.

Figure 4: Location of Screws on MMC (MMC A-4 Servo Unit Shown)

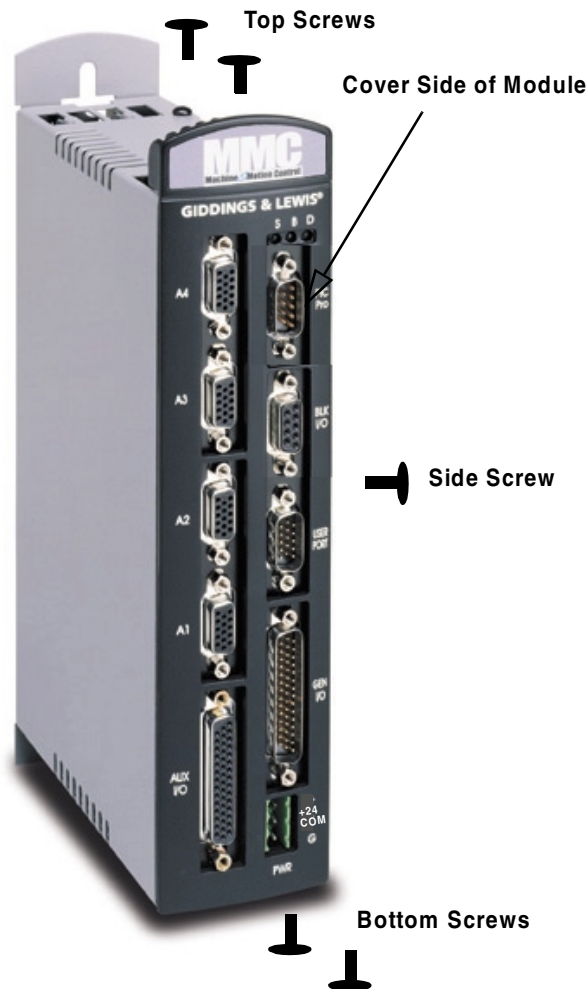

Adding an Option Module to the MMC Control

3. Lift the side cover off and set aside.
4. Locate the 50-pin square post socket at the top of the MMC board. Press one side of the 50-pin square post male connector into this socket ensuring that the pins are aligned and it is firmly seated.
5. Pick up the option module. Line up the socket on the option module with the male end of the connector extending from the MMC ensuring that the pins are aligned. Press firmly into place. Be sure to align the screw tabs on the top and bottom of the option module with the screw slots on the top and bottom of the MMC module so that the modules slide together easily.
6. Screw four screws (of the five included in your package) into the screw tabs to attach the option module to the MMC.
7. Lay the unit on the bench. Place the cover you set aside in Step 3 on the option module. Be sure to align the screw tabs on the top and bottom of the cover with the screw slots on the top and bottom of the option module.
8. Screw the five screws removed in Step 2 back into place to secure the cover.
9. To add an additional option module, repeat the steps above removing the five screws and the cover from the option module on the MMC and then proceeding with steps 4 through 8.

5 Dimensions and Mounting of MMC with Option Module Attached

After attaching the option module to the MMC module, mount the unit to your cabinet using the mounting slots on the MMC and the option module. The recommended size of mounting hardware is #10 bolts with #10 star washers (to ensure proper ground connection).

Figure 5: MMC Mounting Dimensions with Option Module Attached

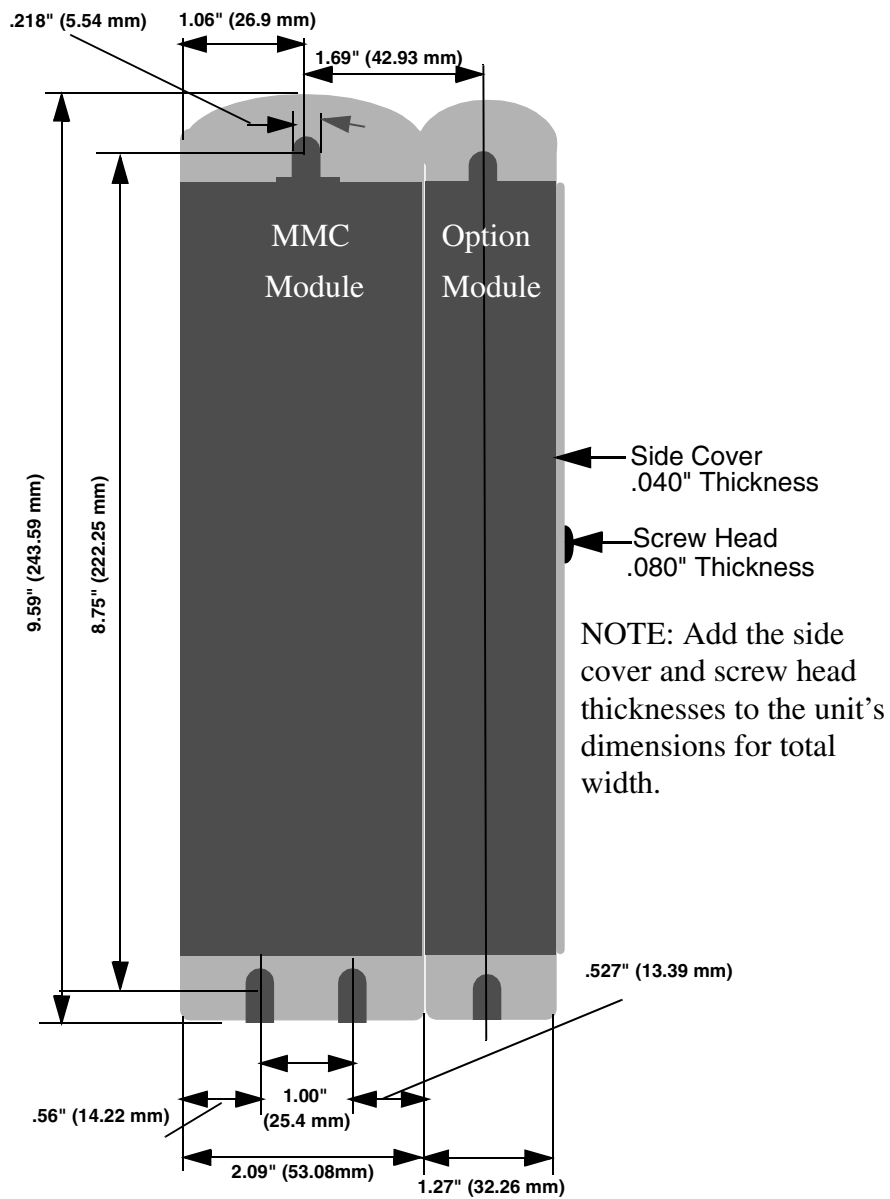

NOTES

6 System Power and Environment Requirements

6.1 General Power and Environment Requirements

The MMC is suitable for operation in a pollution degree 2 environment (i.e., normally, only non-conductive pollution occurs). You are not required to install the system rack in a control cabinet. However a cabinet protects the system from dust and mechanical damage and is recommended.

Power distribution is shown in Figure 6. Install the system rack away from all sources of strong electromagnetic noise. Such noise can interfere with MMC operation.

Protect the MMC system from all the following:

- conductive fluids and particles
- corrosive atmosphere
- explosive atmosphere

The diagrams and recommendations may be modified if necessary so the wiring conforms to current NEC standards or government regulations.

6.2 Control Cabinet Specifications

1. A control cabinet for the MMC should have a NEMA-12 rating or better. A cabinet with this rating protects its contents from dust and mechanical damage.
2. It must be large enough to provide adequate air circulation for the MMC, drives, and other components. Always allow for adequate air flow through the MMC vents.
3. It must have a rigid vertical surface to mount the MMC on.
4. The door should open fully for easy access.

| IMPORTANT |
|------------------------------------------------------------------------------------------------------------|
| Post warnings according to National, State, or local codes for the voltage present in the control cabinet. |

6.3 Power Distribution Diagram

The MMC requires an external DC power source. The power distribution drawing that follows shows an MMC connected to a μ DSM Drive. The drive's 24 VDC power is supplied via the MMC in this example. If the drive has its own external 24 VDC supply, the +24 V line would not be connected.

Figure 6: Example of 24 VDC Power Distribution to an MMC System

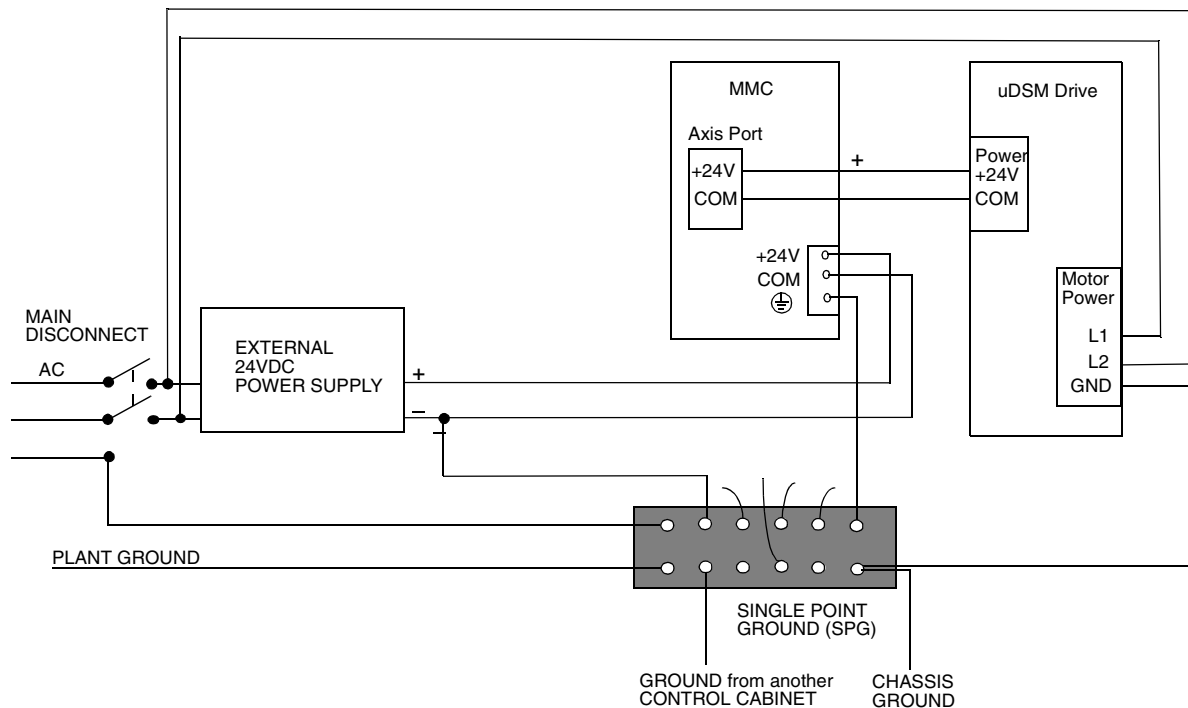

The DC power source is connected to the MMC system through a 3-pin connector. It plugs into the power connector of the MMC. The ground from the power source and ground from the MMC must be connected to the Single-Point Ground (SPG).

Devices connected to the hardware may have their own power sources for input data or output control signals. You can use other wiring setups, provided that each one is:

- at the correct voltage and current levels for the module and the device.
- connected to the same Single-Point Ground that the MMC uses.

It is recommended that the same main disconnect switch be used for the MMC system and for all devices in the application.

IMPORTANT

No matter how the system is installed, before you connect the MMC to the application, make sure that power is off to the system and to the devices the MMC is wired to.

6.4 Notes for 24V Power Supply and MMC

An MMC system consists of a main module (servo analog or SERCOS based) and up to two option modules. An external 24 VDC supply is required to power the MMC's internal circuitry and external I/O. The 24 VDC is distributed internally to three different buses or sections. When you size your power supply, you must ensure that the supply is large enough to handle the total load and that the maximum current capability of each bus is not exceeded. The table below shows the distribution of the 24 VDC power within the MMC system:

| Power Bus | Supplying Current To: | Maximum Current |
|-----------|-----------------------|-----------------|
| 1 | Module Circuitry | 3 A |
| 2 | General I/O | 5 A |
| 3 | Module I/O | 1 A |

In most cases, one power supply can be used for the entire control system. However, depending upon the modules, drives, and external I/O used in your application, you may split the power distribution into two or more power supplies. For example, the Axis I/O on an MMC A2 module can be powered from the MMC, from the drive, or from another external power supply.

CAUTION

A possible ignition hazard within the MMC exists if the maximum currents listed for Bus 2 or Bus 3 are exceeded or if excessive current is drawn at the 24 V line going into the MMC. If these currents might be exceeded (due to improper wiring or external device failure), circuit breakers or fuses should be used in series with the 24 VDC going to and coming from the MMC. Specifically, the circuit breakers or fuses should be sized for 10 A total on the 24V line coming into the MMC, 1 A total from the +24 VDC OUT pins of the AXIS and AUXILIARY I/O connectors, and 5 A total from the I/O 24V pins of the GENERAL I/O connector. For maximum protection, use fast blow fuses. When using molded cables supplied by Giddings & Lewis to connect the MMC to the drives, no overload protection is required.

The following worksheet can be used to size the power supply required by your application.

24 VDC Power Supply Sizing Worksheet

| Line | MMC Module | Current (mA) | # of Units | Col A Subtotal (mA) | Col B Current (mA) |
|------|-----------------------------------------------------------------------------|--------------|------------|---------------------|--------------------|
| 1 | MMC-A2 or MMC-A4 | 250 | | | |
| 2 | MMC SERCOS | 300 | | | |
| 3 | MMC Ethernet | 200 | | | |
| 4 | MMC DeviceNet | 100 | | | |
| 5 | Subtotal, Power Bus 1 (Add Column A, Lines 1 or 2 and 3 or 4 (3000 mA max)) | | | | |

| Line | MMC Component | Max Current (mA) | Actual Current (mA) | Number of I/O | Col A Subtotal (mA) | Col B Current (mA) |
|------|---------------------------------------------------------------|------------------|---------------------|---------------|---------------------|--------------------|
| 6 | General Inputs | 7.5 | 7.5 | | | |
| 7 | General Outputs | 250 | | | | |
| 8 | | 250 | | | | |
| 9 | | 250 | | | | |
| 10 | | 250 | | | | |
| 11 | | 250 | | | | |
| 12 | Subtotal, Power Bus 2 (Add Column A, Lines 6-11, 5000 mA max) | | | | | |
| 13 | Axis inputs | 7.5 | 7.5 | | | |
| 14 | Axis outputs | 100 | | | | |
| 15 | | 100 | | | | |
| 16 | | 100 | | | | |
| 16 | | 100 | | | | |
| 17 | Auxiliary inputs | 7.5 | 7.5 | | | |
| 18 | Fast inputs | 7.5 | 7.5 | | | |
| 19 | Current supplied by AXIS +24 VDC Out pins | | | | | |
| 20 | Current supplied by AUX +24 VDC Out pins | | | | | |
| 21 | Subtotal Power Bus 3 (Add Column A, Lines 13-20, 1000 mA max) | | | | | |
| 23 | MMC Power (Add Column B, Lines 5, 12, and 21, 10,000 mA max) | | | | | |
| 24 | Other (i.e. block I/O) | | | | | |
| 25 | | | | | | |
| 26 | | | | | | |
| 27 | Subtotal (Add Column A, Lines 24-27) | | | | | |
| 25 | Total Power (Add Column A, Lines 23 and 27) | | | | | |

Below is an example showing how to use the worksheet to calculate the maximum current required for a theoretical four axes MMC.

24 VDC Power Supply Sizing Example

| Line | MMC Module | Current (mA) | # of Units | Col A Subtotal (mA) | Col B Current (mA) |
|------|-----------------------------------------------------------------------------|--------------|------------|---------------------|--------------------|
| 1 | MMC-A2 or MMC-A4 | 250 | 1 | 250 | 250 |
| 2 | MMC SERCOS | 300 | | | |
| 3 | MMC Ethernet | 200 | | | |
| 4 | MMC DeviceNet | 100 | | | |
| 5 | Subtotal, Power Bus 1 (Add Column A, Lines 1 or 2 and 3 or 4 (3000 mA max)) | | | | 250 |

| Line | MMC Component | Max Current (mA) | Actual Current (mA) | Number of I/O | Col A Subtotal (mA) | Col B Current (mA) |
|------|---------------------------------------------------------------|------------------|---------------------|---------------|---------------------|--------------------|
| 6 | General Inputs | 7.5 | 7.5 | 16 | 120 | |
| 7 | General Outputs | 250 | 250 | 16 | 4000 | |
| 8 | | 250 | | | | |
| 9 | | 250 | | | | |
| 10 | | 250 | | | | |
| 11 | | 250 | | | | |
| 12 | Subtotal, Power Bus 2 (Add Column A, Lines 6-11, 5000 mA max) | | | | | 4120 |
| 13 | Axis inputs | 7.5 | 7.5 | 4 | 30 | |
| 14 | Axis outputs | 100 | 100 | 8 | 200 | |
| 15 | | 100 | | | 100 | |
| 16 | | 100 | | | 60 | |
| 16 | | 100 | | | | |
| 17 | Auxiliary inputs | 7.5 | 7.5 | 16 | 120 | |
| 18 | Fast inputs | 7.5 | 7.5 | 5 | 40 | |
| 19 | Current supplied by AXIS +24 VDC Out pins | 100 | | | 100 | |
| 20 | Current supplied by AUX +24 VDC Out pins | 300 | | | 300 | |
| 21 | Subtotal Power Bus 3 (Add Column A, Lines 13-20, 1000 mA max) | | | | | 950 |
| 23 | MMC Power (Add Column B, Lines 5, 12, and 21, 10,000 mA max) | | | | 5320 | |
| 24 | Other (i.e. block I/O) | | | | | |
| 25 | | | | | | |
| 26 | | | | | | |
| 27 | Subtotal (Add Column A, Lines 24-27) | | | | 0 | |
| 25 | Total Power (Add Column A, Lines 23 and 27) | | | | 5320 | |

6.5 Grounding the System

The ground of the MMC power source must be connected directly to a Single Point Ground (SPG) tie block. The tie block should be made of brass or copper, bolted or brazed to the control cabinet. If the tie block is bolted rather than brazed, scrape away paint or grease at the point of contact. Put star washers between the tie block and the cabinet to ensure good electrical contact.

Metal enclosures of power supplies, drives, etc., should also have good electrical contact with the SPG.

CAUTION

The Single Point Ground should be the only common point for all the ground lines. If not, ground loops may cause current flow between components of the system which can interfere with proper operation of the MMC.

Devices to be connected directly to the Single Point Ground include:

- Plant safety ground.
- Chassis ground from MMC power connector.
- The metal panel or cabinet on which the MMC is mounted.
- "Common" or "0 V" lines from power supplies that provide external power to the I/O modules and the devices to which they are connected.
- Chassis grounds from the devices themselves, such as device drivers, machinery, and operator interface devices.
- AC common line from the noise filter, if any.
- The ground of the power source of the computer workstation, if any, from which you monitor the system operation. An AC outlet in the control cabinet is recommended.
- Single point grounds from other control cabinets, if any, in the system.

IMPORTANT

You must ensure that the "0V" or "Common" of all devices connected to the MMC are connected to Single Point Ground (SPG). Failure to do so may result in erratic operation or damage to the MMC. Examples of devices connected to the MMC include the power source that supplies 24VDC power to the MMC and devices connected to the MMC PiCPro Port or User Port. Note that some devices (for example, a Personal Computer) may have their "0V" and "Chassis" connected together internally, in which case only one connection has to be made to SPG for that device.

Also, you must ensure that the MMC "Chassis connection is connected to SPG, and that the MMC is mounted to a metal panel or enclosure that is connected to SPG.

6.6 Controlling Heat Within the System

The MMC hardware case is designed to promote air circulation and dissipate heat. The MMC can be mounted vertically or horizontally to take advantage of this design. Normally no fans or air conditioners are needed. However, if the environment outside the control cabinet is hot or humid, you may need to use a fan, heat exchanger, dehumidifier or air conditioner to provide the correct operating environment.

Table 1: Operating Limits for the MMC

| | |
|-------------------|---------------------------|
| Temperature | 5 to 55° C (41 to 131° F) |
| Relative humidity | 5 to 95%, non-condensing |

Make sure that components installed in the cabinet with the MMC do not raise the temperature above system limits and that any hot spots do not exceed specifications. For example, when heat-generating components such as transformers, drives or motor controls are installed, separate them from the system by doing one of the following:

- Place them near the top of the control cabinet so their heat output rises away from the MMC.
- Put them in another control cabinet above or to one side of the cabinet with the MMC. This protects the MMC from both heat and electrical noise.

The MMC itself is a source of heat, though in most installations its heat dissipates without harmful effects. System heat is generated from power dissipated by:

- field side input/output components
- other components within the MMC

CAUTION

If the MMC is operated outside the recommended limits, it may be damaged. This will void the warranty.

6.7 Handling an MMC

The case protects the MMC's internal circuitry against mechanical damage in shipping and handling. However, like any electronics device, the circuitry can be destroyed by:

- temperatures over 55° C (131° F)
- moisture condensing inside the module
- static discharge
- exposure to a magnetic field strong enough to induce a current in the circuitry
- freezing temperatures, vibration, and other hazards

Normally there is no need to open the case. Occasionally, a battery must be replaced. A diagram and detailed anti-static precautions in the appendices are included with modules that have replaceable components.

7 System Wiring Guidelines

The MMC relies on electrical signals to report what is going on in the application and to send commands to it. In addition, signals are constantly being exchanged within the system. The MMC is designed for use in industrial environments, but some guidelines should be followed.

7.1 Recommended Signal Separation

Giddings & Lewis continues to recommend separation of low level signals (encoder, analog, communications, fast DC inputs) from high voltage or high current lines. Maintain at least one inch of separation around signals.

Figure 7 illustrates the recommended connections when using EMC compliant products. Note that a capacitor is connected to the 24 VDC supply. To prevent excessive conducted emissions from a DC power source (typically 24 V) used for digital I/O, a 1000 picofarad capacitor should be used. Connect the capacitor from the +24 VDC to COMMON at the distribution terminals.

Figure 7: Recommended EMC Compliant Connections

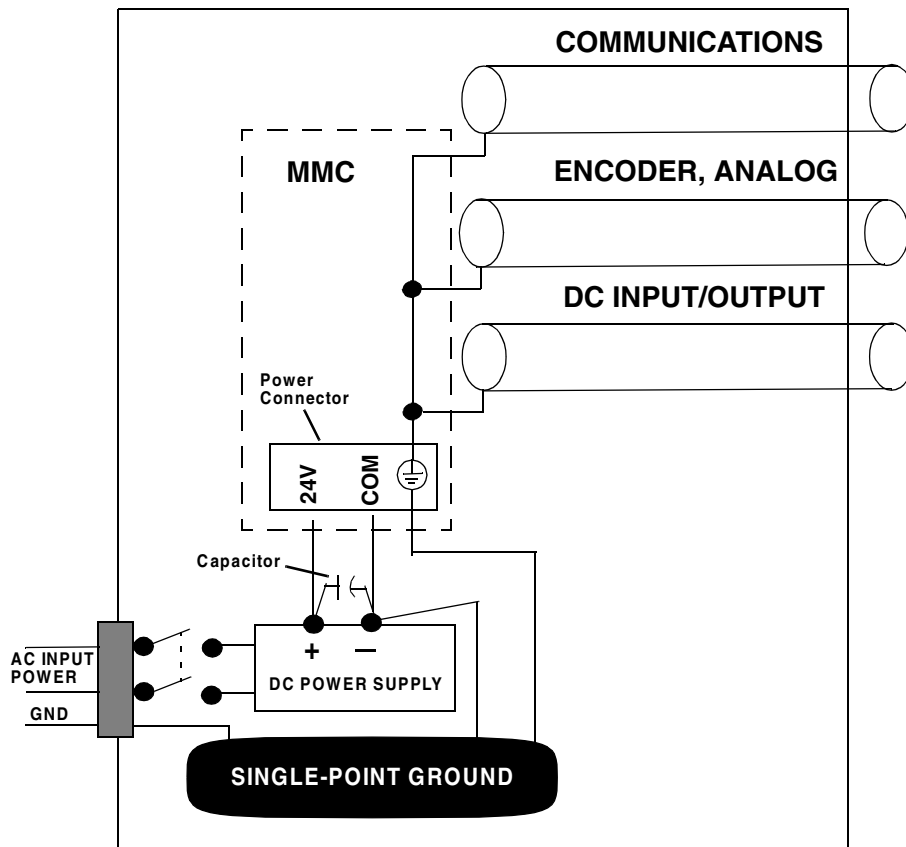

Inside a control cabinet, connect the shields of shielded cables at the MMC. Figure 8 illustrates shielded cable entering/leaving the cabinet.

Figure 8: Connecting Shielded Cable

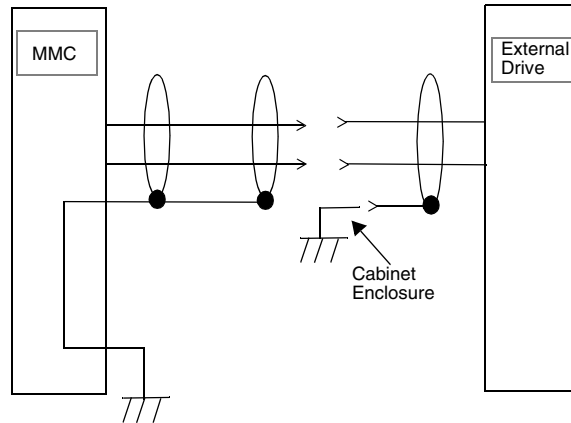

The two different methods of terminating shields are used to accommodate two different immunity requirements. Immunity required inside an enclosure is considered lower because cables are typically less than three meters in length and/or can be separated from each other and from noise sources.

Immunity required external to an enclosure is considered higher because the user may have less control over the noise environment. Low level signal cables that can be external to an enclosure are tested at a 2 KV level for electrical fast transients (EFTs). Low level signals that can be less than three meters in length or can be separated from noise sources are tested at a 1 KV level. Under the stated conditions, there will be no disturbance of digital I/O, encoder, or stepper operation. For analog signals, there may be momentary disturbances but there will be self-recovery when the noise subsides.

Do not operate transmitters, arc welding equipment, or other high noise radiators within one meter of an enclosure that has the door open. Continue to equip inductive devices, if they are in series with a mechanical contact or switch, with arc suppression circuits. These devices include contactors, solenoids and motors. Shield all cables that carry heavy current near the system, using continuous foil wrap or conduit grounded at both ends. Such cables include power leads for high-frequency welders and for pulse-width-modulated motor drives.

WARNING

Use care when wiring I/O devices to the MMC and when plugging in cables. Wiring the wrong device to the connector or plugging a connector into the wrong location could cause intermittent or incorrect machine operation.

7.2 Differential Devices for Analog and Encoder Signals

A *differential* device receives or sends one signal over two wires (typically a shielded twisted pair). The input/output voltage at the second terminal is the inverse of the first. Information is received/sent as the difference between the two voltages.

Figure 9: Differential Digital Pulse Train

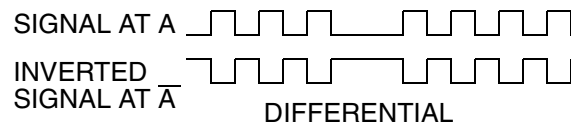

The advantages of using differential signals are:

1. A differential signal is less susceptible to electromagnetic noise. Static or other interference affects both of the twisted-pair wires equally, so the difference between the normal and inverted voltage remains unchanged. A differential signal can be transmitted over a much longer distance or in a much noisier environment than a single-ended one.
2. MMC hardware circuitry can detect signal loss from an encoder if the signal is differential. The application program can be set to shut down the application if such an error is detected.

IMPORTANT

Always use differential drivers or differential inputs.

NOTES

8 Starting an Operation

Good procedure suggests that the system should be tested each time a new application is powered up. The DIAG LED on the MMC should be off indicating that the diagnostic tests were passed.

Turn off the main disconnect switch and plug the DC connector into the power connector. Turn on input power. The DIAG LED turns on and then turns off when the MMC passes its diagnostic tests.

8.1 Connecting the MMC to the Application

1. Turn off the main disconnect switch in the control cabinet. If some devices are not powered from the control cabinet, turn them off also.
2. Connect the connectors according to your diagrams.
3. Turn on power to the system. The PWR light goes on and stays on. The DIAG light goes on, then goes off in turn. The SCAN light goes on. The application starts to work under control of the system.
4. If an application program is not in system memory, use the download command in the PiCPro software to place it there.

8.2 Troubleshooting

Table 2 summarizes how to proceed when performing certain maintenance and/or setup functions.

Table 2: Summary

| In order to: | |
|-----------------------------------------------------------------------------------|---------------------------------------------------------------------------------------------------------------------------------------|
| Turn off the entire application. | Turn off main disconnect (which should also turn off all external power supplies to the application); unplug the DC power to the MMC. |
| Wire the I/O to the application. | Turn off main disconnect (which should also turn off all external power supplies to the application); unplug the DC power to the MMC. |
| Change the battery. | Turn off main disconnect (which should also turn off all external power supplies to the application); unplug the DC power to the MMC. |
| Connect/disconnect the MMC with the computer workstation through the PiCPro port. | Turn off main disconnect (which should also turn off all external power supplies to the application); unplug the DC power to the MMC. |
| Connect/disconnect the MMC with an operator interface through the User port. | Turn off main disconnect (which should also turn off all external power supplies to the application); unplug the DC power to the MMC. |
| Download an application program into the memory. | Make sure power is on (check the P LED). |
| Stop the scan. | From the workstation - use the Stop Scan commands in the PiCPro software. |

8.3 Diagnostics

This section covers two types of diagnostics; power-on and run-time.

8.3.1 Power-On Diagnostics

When the system is powered up, it tests itself and reports the results of the tests in the form of LED signals.

8.3.1.1 Power LED

If the power light (P) does not go on, or goes off during operation of the system, check that power is still connected to the MMC. If it is, turn off the main disconnect switch and replace the MMC.

8.3.1.2 Scan LED

If the SCAN LED does not go on:

1. Check that the power (P) light is ON.
2. Check that the diagnostic (D) light is OFF.

8.3.1.3 Diagnostic LEDs

The MMC has an LED marked D which lights up briefly while its diagnostic tests are running and then goes off. If the DIAG LED remains on, the MMC has failed one of its tests. Follow these steps:

1. Turn off power to the system and to the application.
2. If the I/O wiring is connected, remove the connector .
3. Remove the defective MMC from the system
4. Replace with a new MMC. Connect the I/O wiring.
5. Turn on power to check diagnostics again.

NOTE

Diagnostics are run only when the system is powered up. It is possible that a failure might occur during operation. If so, its DIAG light remains off. If you suspect that a module might be defective, cycle power to run diagnostics again.

8.3.2 Run-Time Diagnostics

While the MMC is running, other tests are performed on a regular basis with their results also reported by LEDs.

- If the POWER (P) LED on the MMC starts flashing, the battery must be replaced. Follow the battery replacement procedure in this document.
- While the MMC is running, the DIAG LED will flash a three digit code signal if there is an error. For example, if there is a long pause-flash-pause-flash-flash-pause-flash-flash-flash-long pause, the code is 123. The errors are described in the LED section of this document.

9 MMC Connections to External Devices for Machine Control

Giddings & Lewis provides many optional accessories that simplify wiring the MMC to external devices. These accessories include cables to connect the MMC to Giddings & Lewis's line of DSM and Micro DSM drives and breakout boxes that provide screw-terminal connections to the MMC. Consult the factory for further information.

9.1 PiCPro Port

The PiCPro port provides serial communication for the PiCPro programming interface.

| Pin | Description | In/Out |
|-----|---------------------|--------|
| 1 | NC | |
| 2 | Receive Data | In |
| 3 | Transmit Data | Out |
| 4 | Data Terminal Ready | Out |
| 5 | Signal Ground | In/Out |
| 6 | NC | |
| 7 | Request to Send | Out |
| 8 | NC | |
| 9 | NC | |

The pinout for a typical PiCPro Port cable is shown below.

PiCPro Cable Pinout

| 9-pin female (to PC) | | 9-pin female (to PiCPro Port) |
|-------------------------|----|----------------------------------|
| 3 | to | RD 2 |
| 2 | to | TD 3 |
| 5 | to | GND 5 |

9.2 Block I/O Port

The block I/O port provides up to 77 expansion block I/O units, 4-wire communication interface and up to 200 feet between block I/O units

| Type | Controller Block I/O 9-Pin D-Sub Female Connector | | | | Block I/O Communications Connector (In from Controller) | | |
|--------------|------------------------------------------------------|-------------------|------------|----|---------------------------------------------------------------|-------------------|------------|
| | Pin | Description | In/ Out | | Pin | Description | In/ Out |
| | 1 | NC | | | | | |
| | 2 | NC | | | | | |
| Twisted Pair | 3 | Transmit Data + | Out | to | 1 | Receiver + | In |
| | 4 | Transmit Data - | Out | to | 2 | Receiver - | In |
| Twisted Pair | 5 | Receive Data + | In | to | 4 | Driver + | Out |
| | 6 | Receive Data - | In | to | 5 | Driver - | Out |
| | 7 | Shield (see Note) | | | 3 | Shield (see Note) | |
| | 8 | NC | | | | | |
| | 9 | NC | | | | | |

NOTE: Pin 7 of the Block I/O port connector is connected to the connector shell within the controller. Therefore, the shield may be connected to either pin 7 or the connector shell.

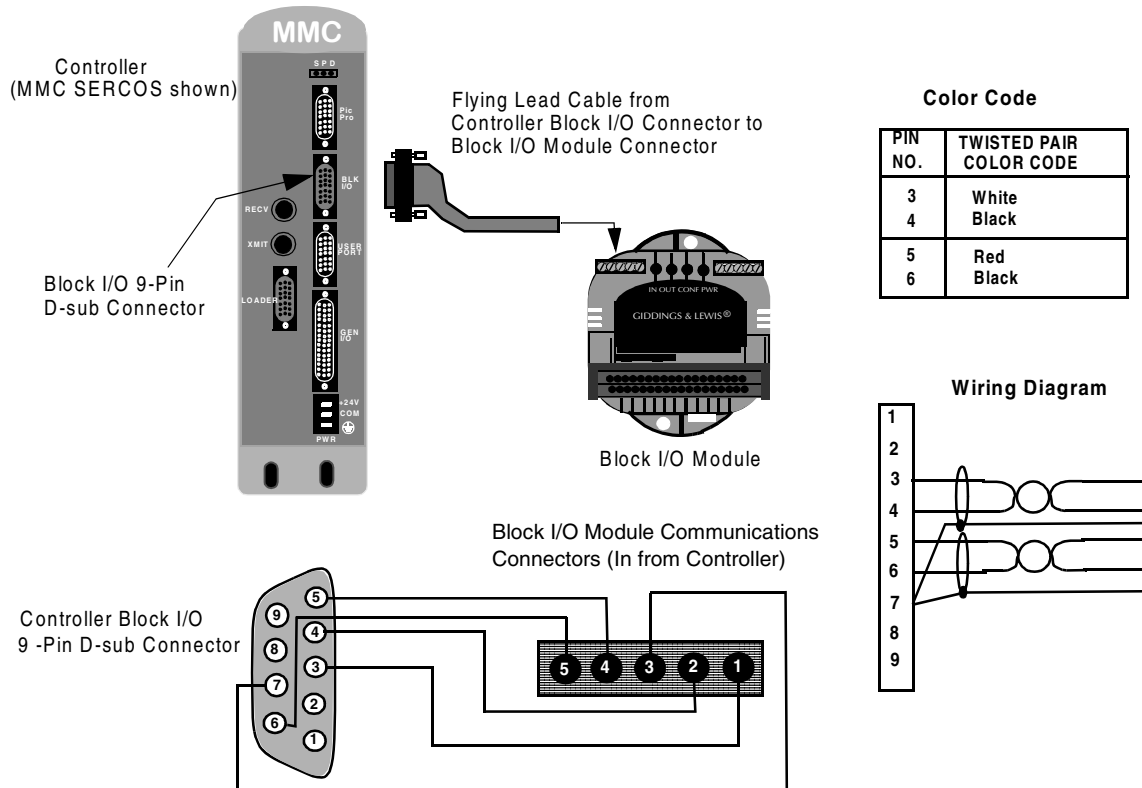

9.3 User Port

The User Port is used to communicate with a touch-screen, a hand-held controller, or other serial interface device. The user port provides:

- RS232/RS485 communication
- Baud rates to 19.2 K
- Multidrop capability

| Pin | Description | In/Out | Pin | Description | In/Out |
|-----|---------------------------|--------|-----|-----------------------|--------|
| 1 | NC | | 9 | RS232 Receive Data | In |
| 2 | NC | | 10 | RS232 Transmit Data | Out |
| 3 | +5V (50mA Max) | Out | 11 | NC | |
| 4 | RS232 Data Terminal Ready | Out | 12 | RS485 Receive Data + | In |
| 5 | RS232 Request to Send | Out | 13 | RS485 Receive Data - | In |
| 6 | NC | | 14 | RS485 Transmit Data + | Out |
| 7 | RS232 Clear to Send | In | 15 | RS485 Transmit Data - | Out |
| 8 | Signal Ground | In/Out | | | |

9.4 General I/O Port

The general I/O port includes:

- 16 24 VDC inputs
Sink or source in groups of eight Inputs 1 and 9 can trigger an interrupt on the rising or falling edge
- +24 VDC and 24 V Common
- 16 24 VDC outputs Source only 250 mA output capacity short circuit protected

| Pin | Description | In/Out | Pin | Description | In/Out | Pin | Description | In/Out |
|-----|-------------|--------|-----|-------------|--------|-----|-------------|--------|
| 1 | DCOUT1 | Out | 16 | DCOUT16 | Out | 31 | NC | |
| 2 | DCOUT2 | Out | 17 | NC | | 32 | NC | |
| 3 | DCOUT3 | Out | 18 | NC | | 33 | NC | |
| 4 | DCOUT4 | Out | 19 | NC | | 34 | IO24V | Out |
| 5 | DCOUT5 | Out | 20 | IO24V | Out | 35 | DCSS2 | In |
| 6 | DCOUT6 | Out | 21 | DCSS1 | In | 36 | IO24C | Out |
| 7 | DCOUT7 | Out | 22 | IO24C | Out | 37 | DCIN9 | In |
| 8 | DCOUT8 | Out | 23 | DCIN1 | In | 38 | DCIN10 | In |
| 9 | DCOUT9 | Out | 24 | DCIN2 | In | 39 | DCIN11 | In |
| 10 | DCOUT10 | Out | 25 | DCIN3 | In | 40 | DCIN12 | In |
| 11 | DCOUT11 | Out | 26 | DCIN4 | In | 41 | DCIN13 | In |
| 12 | DCOUT12 | Out | 27 | DCIN5 | In | 42 | DCIN14 | In |
| 13 | DCOUT13 | Out | 28 | DCIN6 | In | 43 | DCIN15 | In |
| 14 | DCOUT14 | Out | 29 | DCIN7 | In | 44 | DCIN16 | In |
| 15 | DCOUT15 | Out | 30 | DCIN8 | In | | | |

There are 16 DC outputs on the general connector. These outputs get their power internally from the MMC as shown in Figure 10

Figure 10: General Outputs Connected to Loads

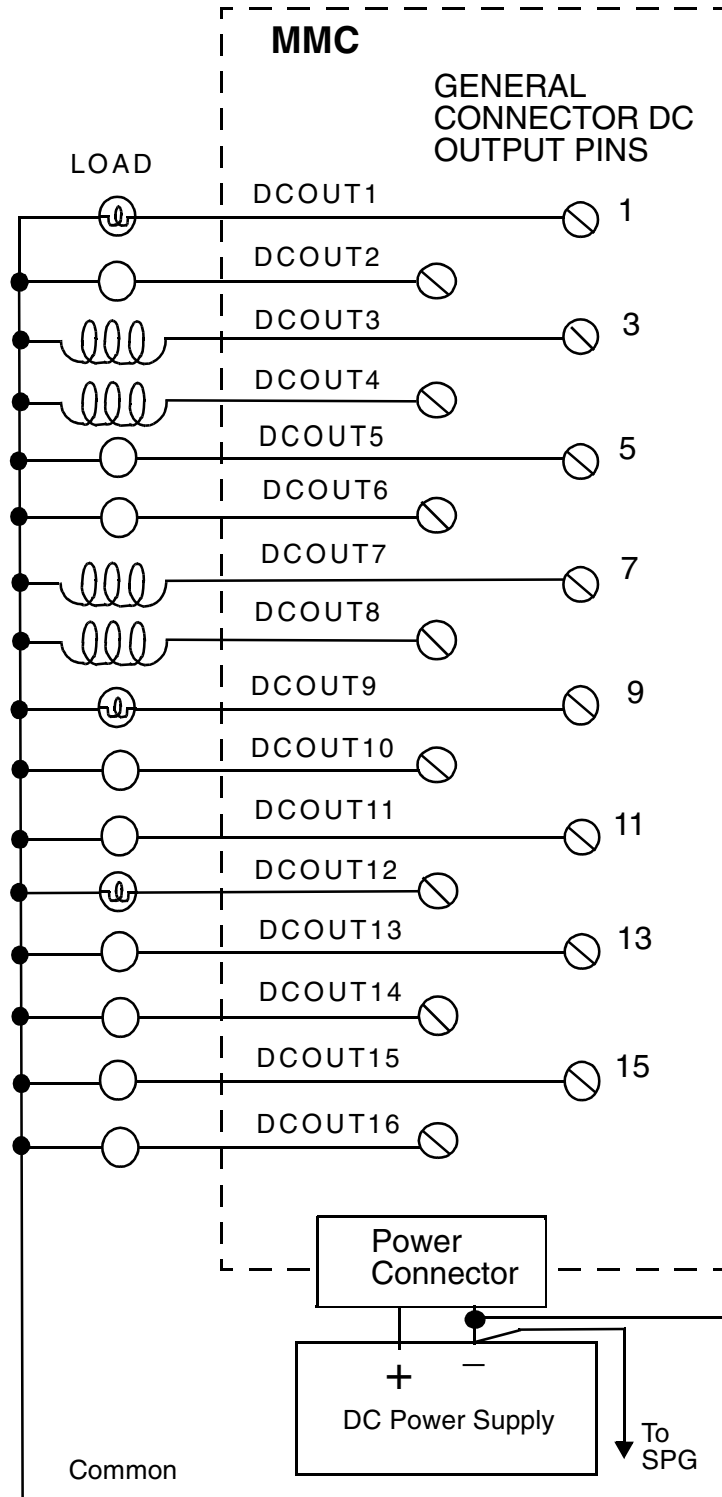

There are 16 general inputs on the general connector. The inputs are configured as two groups of eight. Each group can be configured as sourcing or sinking. Connect the DCSS pin to +24 V for a sourcing configuration. Connect the DCSS pin to COM for a sinking configuration. You can use the internal +24 V supply as shown in Figure 11.

Figure 11: Sink/Source General Input Configuration

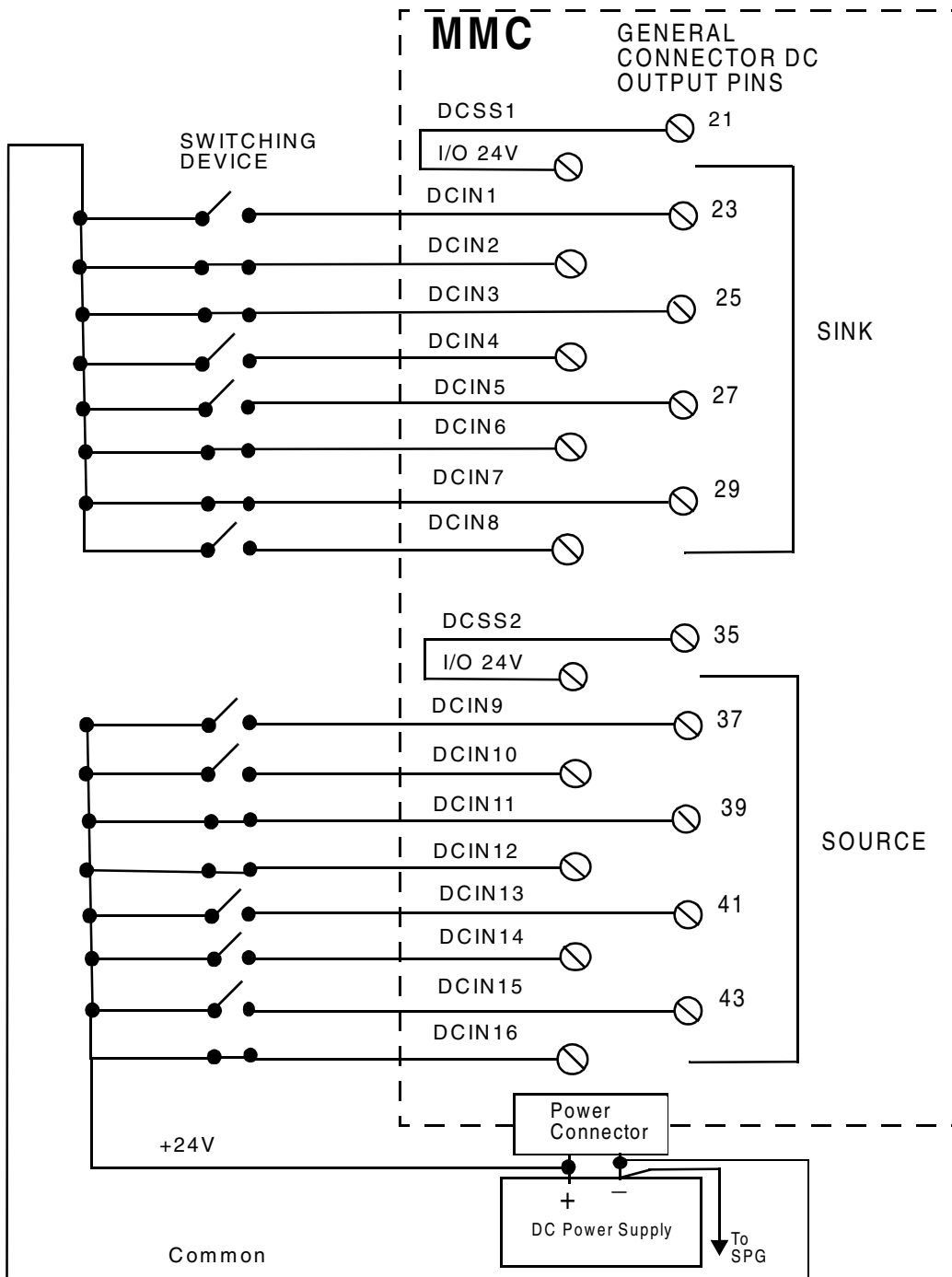

9.5 Power Connection

You must provide a +24 VDC power supply as the power source for the MMC. The power supply screw terminal connection (3 pin) is at the bottom of the CPU section of the MMC. This +24 V appears as an output at several points on the MMC connectors. Figure 12 illustrates the pin-out.

Figure 12: Pin Out for the 3-pin Power Supply Screw Terminal Connection

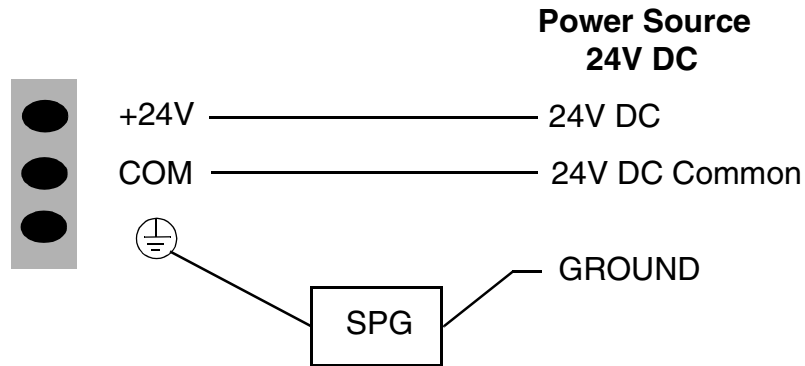

The 24 VDC applied at the MMC input power connector is also available:

- To power the DC outputs
- To power the sink/source inputs
- To power the axes interface
- To power the optional Ethernet or DeviceNet modules

NOTES

10 MMC Analog Servo Connections for Motion Control

There are four Axis connectors and one Auxiliary I/O connector on the MMC analog board.

10.1 Axis Connectors

Each axis has its own 15 pin high density D connector. Each axis connector provides the following signal connections:

- One 16-bit resolution analog output (± 10 VDC)
- One quadrature, incremental encoder input
- Two DC outputs (24 VDC sink or source)
- One DC input (24 VDC sink or source)
- +24 VDC output

These signals are typically connected to the drive as shown below.

| MMC Axis Signal | Connection |
|-----------------|-------------------------|
| Analog output | Drive command |
| Encoder input | Drive encoder output |
| DC output 1 | Drive enable input |
| DC output 2 | Drive reset input |
| DC input 1 | Drive fault output |
| DCOSS | +24V or COMMON (on MMC) |

The axis connector pinout is listed below.

| Pin | Description | Pin | Description |
|-----|-------------|-----|-------------|
| 1 | A | 9 | DA- |
| 2 | A/ | 10 | I/ |
| 3 | B | 11 | +24 VDC out |
| 4 | B/ | 12 | COM |
| 5 | I | 13 | DCOUT1 |
| 6 | DCIN+ | 14 | DCOUT2 |
| 7 | DCIN- | 15 | DCOSS |
| 8 | DA+ | | |

The metal shell of the 15-pin connector is tied to the chassis ground terminal on the MMC power connector. Cables provided by Giddings & Lewis will have the shield connected to the metal shell of the cable connector. If you use other cables, be sure to connect the shield to the metal shell of the connector.

The DC outputs can be configured for either sink or source operation. When the DCOSS pin is tied to the +24V, the outputs will be in a source configuration as shown in Figure 13.

Figure 13: Source Configuration

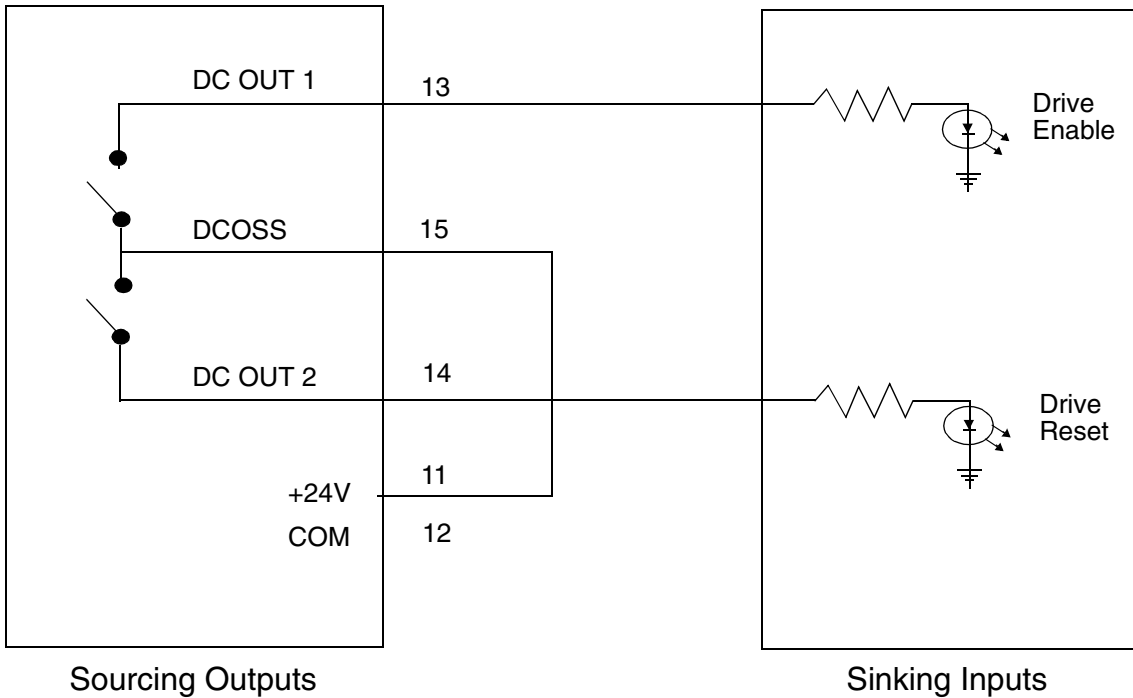

When the DCOSS pin is tied to COMMON, the outputs will be in a sink configuration as shown in Figure 14.

Figure 14: Sink Configuration

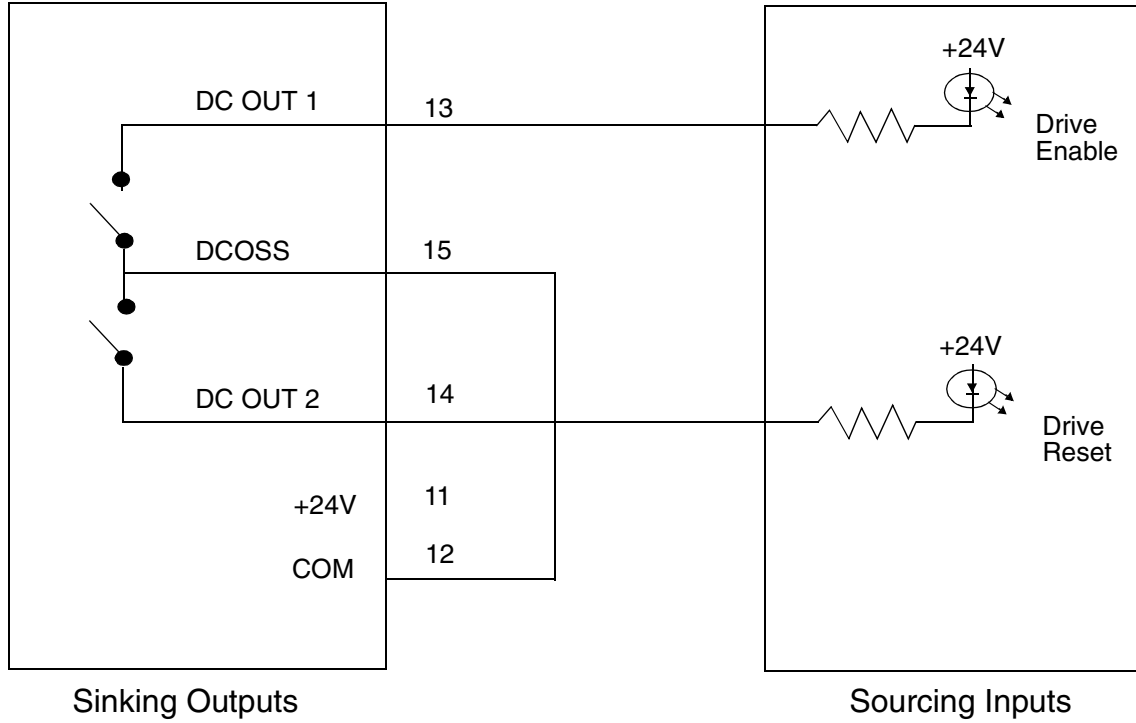

The analog output is connected to the drive command input. Twisted pair wire should be used to make the connection between the analog output and the drive as shown in Figure 15.

Figure 15: Axis Analog Output Connected to Drive Command Input

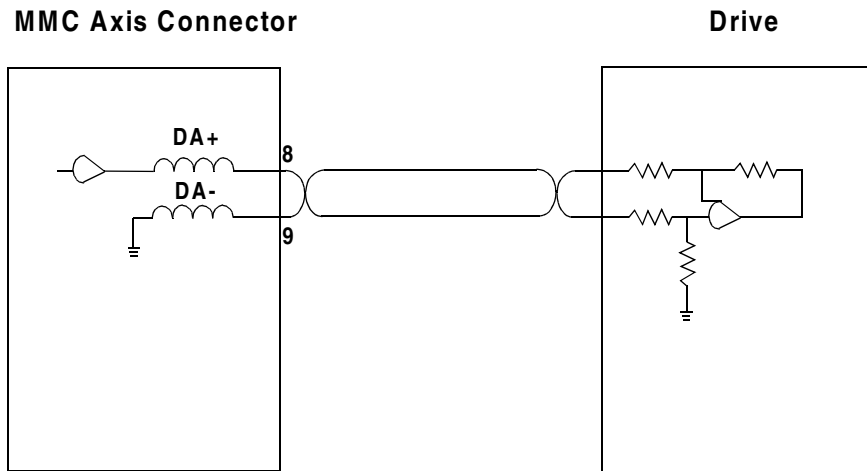

Drives will typically have an output signal indicating that the drive is operational. This "drive ready" signal can be connected to the Axis DC Input. One of the input pins should be connected to either +24 V or COM. The remaining input pin should be tied to the input signal that will be switching. Refer to Figure 16.

Figure 16: Axis DC Input Connected to Drive Ready

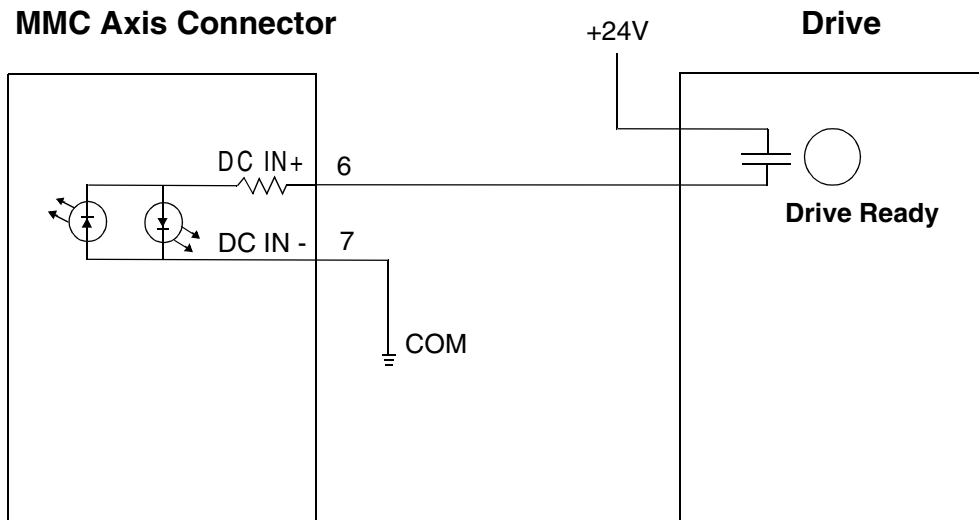

The encoder output signals from the drive should be connected to the encoder input on each axis. The MMC analog section accepts RS422 level differential inputs. The encoder signals should be quadrature type. All encoder wiring between the MMC and the drive should be shielded twisted pair.

NOTE

The encoder input on the auxiliary connector is identical to the encoder inputs on the axis connectors. See Figure 17.

Figure 17: MMC Encoder Inputs Connected to Drive Encoder Outputs

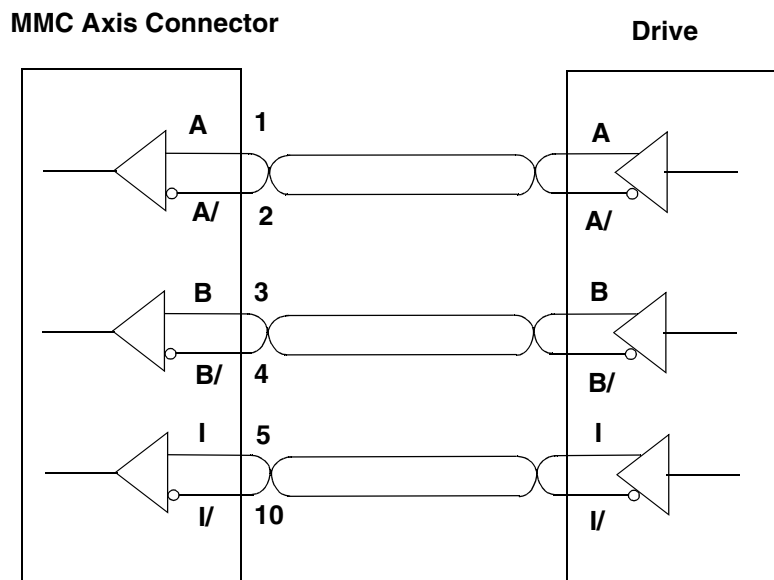

10.2 Auxiliary I/O Connector

The auxiliary I/O 44-pin connector provides the following inputs:

- One quadrature, incremental encoder channel (1 Mhz frequency, RS422 interface)
- Five fast DC inputs (one per encoder input) for high speed position latching)
- One 12-bit resolution analog input channel
- 12 optically isolated DC inputs
- +24 VDC output
- +5 VDC output
- Seven Shields

The auxiliary I/O connector pinout for the MMC-A4 (4 axes) is listed below.

| Pin | Description | Pin | Description | Pin | Description |
|-----|-------------|-----|-------------|-----|-------------|
| 1 | A | 16 | FASTIN1+ | 31 | DCSSA |
| 2 | A/ | 17 | FASTIN1- | 32 | DCIN1 |
| 3 | B | 18 | SHIELD | 33 | DCIN2 |
| 4 | B/ | 19 | FASTIN2+ | 34 | DCIN3 |
| 5 | I | 20 | FASTIN2- | 35 | DCIN4 |
| 6 | I/ | 21 | SHIELD | 36 | DCIN5 |
| 7 | SHIELD | 22 | FASTIN3+ | 37 | DCIN6 |
| 8 | +24 VDC out | 23 | FASTIN3- | 38 | DCSSB |
| 9 | +24 VDC out | 24 | SHIELD | 39 | DCIN7 |
| 10 | COM | 25 | FASTIN4+ | 40 | DCIN8 |
| 11 | COM | 26 | FASTIN4- | 41 | DCIN9 |
| 12 | +5 VDC out | 27 | SHIELD | 42 | DCIN10 |
| 13 | ANLGIN+ | 28 | FASTIN5+ | 43 | DCIN11 |
| 14 | ANLGIN- | 29 | FASTIN5- | 44 | DCIN12 |
| 15 | SHIELD | 30 | SHIELD | | |

The auxiliary I/O connector pinout for the MMC-A2 (2 axes) is listed below

| Pin | Description | Pin | Description | Pin | Description |
|-----|-------------|-----|-------------|-----|-------------|
| 1 | A | 16 | FASTIN1+ | 31 | DCSSA |
| 2 | A/ | 17 | FASTIN1- | 32 | DCIN1 |
| 3 | B | 18 | SHIELD | 33 | DCIN2 |
| 4 | B/ | 19 | FASTIN2+ | 34 | DCIN3 |
| 5 | I | 20 | FASTIN2- | 35 | DCIN4 |
| 6 | I/ | 21 | SHIELD | 36 | DCIN5 |
| 7 | SHIELD | 22 | NC | 37 | DCIN6 |
| 8 | +24 VDC out | 23 | NC | 38 | NC |
| 9 | +24 VDC out | 24 | SHIELD | 39 | NC |
| 10 | COM | 25 | NC | 40 | NC |
| 11 | COM | 26 | NC | 41 | NC |
| 12 | +5 VDC out | 27 | SHIELD | 42 | NC |
| 13 | ANLGIN+ | 28 | FASTIN5+ | 43 | NC |
| 14 | ANLGIN- | 29 | FASTIN5- | 44 | NC |
| 15 | SHIELD | 30 | SHIELD | | |

Each encoder channel has a fast DC input associated with it. The fast input can be used to latch the encoder position. Shielded twisted pair wiring should be used for all fast input connections. The fast inputs can be connected in either a source or sink configuration. The source configuration is illustrated in Figure 18.

Figure 18: Fast Inputs Connected Using Shielded Twisted Pair (Source)

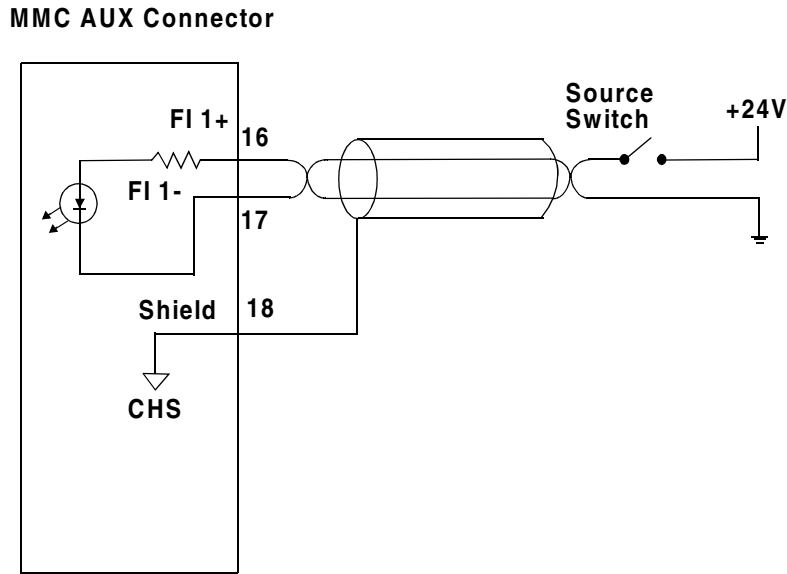

The fast input sink configuration is illustrated in Figure 19.

Figure 19: Fast Inputs Connected Using Shielded Twisted Pair (Sink)

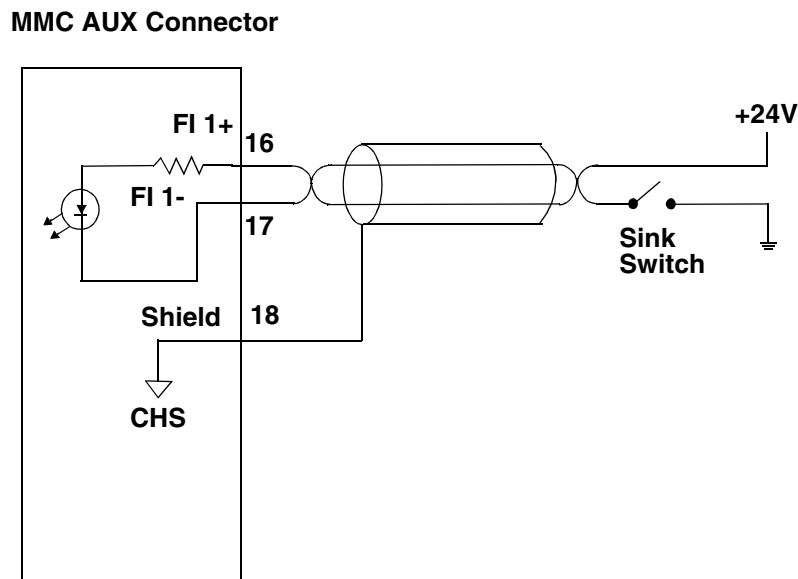

There are 12 general purpose inputs on the auxiliary connector. The inputs are configured as two groups of six. Each group can be configured as sourcing or sinking. Connect the DCSS pin to +24 V for a sourcing configuration. Connect the DCSS pin to COM for a sinking configuration. You can use the internal +24 V supply as shown in Figure 20. The 12 inputs are available on the four axis MMC. The two axis MMC has six inputs. See the pinouts on pages 46 and 47 for those connections.

Figure 20: Sink/Source Connections using Internal +24 V Supply (4-Axis MMC)

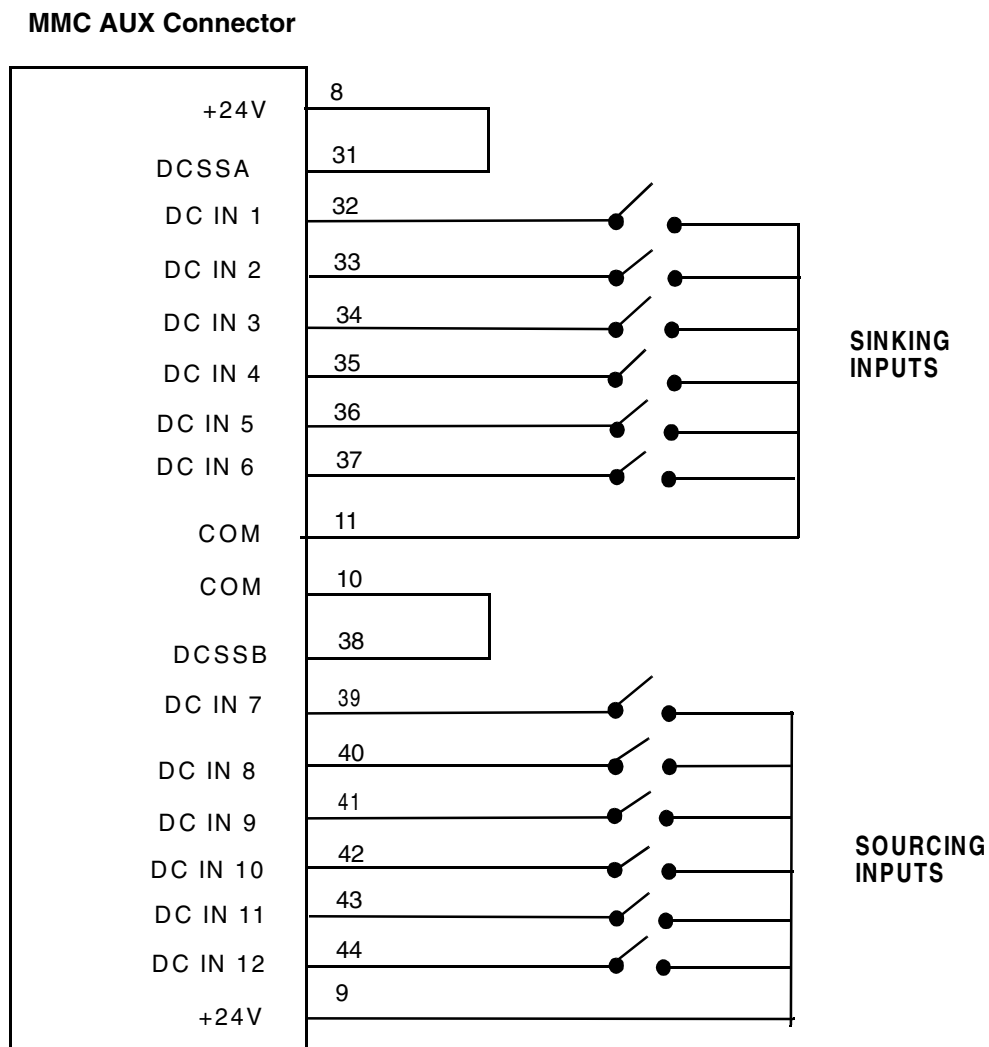

Or you can use an external +24 V supply as shown in Figure 21

Figure 21: Sink/Source Connections using External DC Supply(4-Axis MMC)

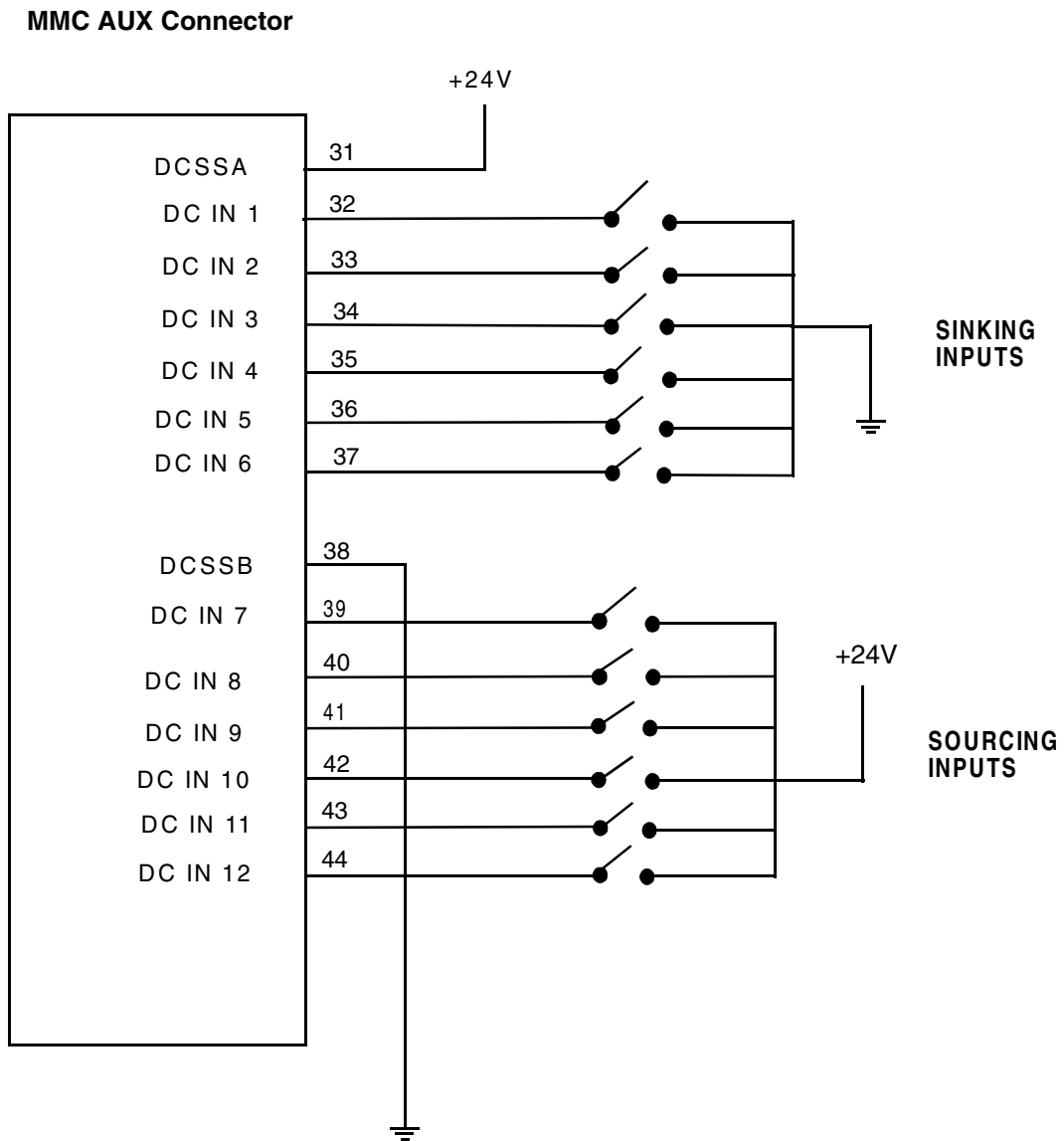

11 MMC SERCOS Connections for Motion Control

11.1 SERCOS Receive and Transmit Ports

The SERCOS port located in the center of the board can connect to one SERCOS ring. The connection to this ring is made through a pair of female fiber optic SMA connectors. The module's transmitter is connected to the first receiver in the loop and the module's receiver is connected to the last transmitter in the loop.

Figure 22: SERCOS Connections - One Ring

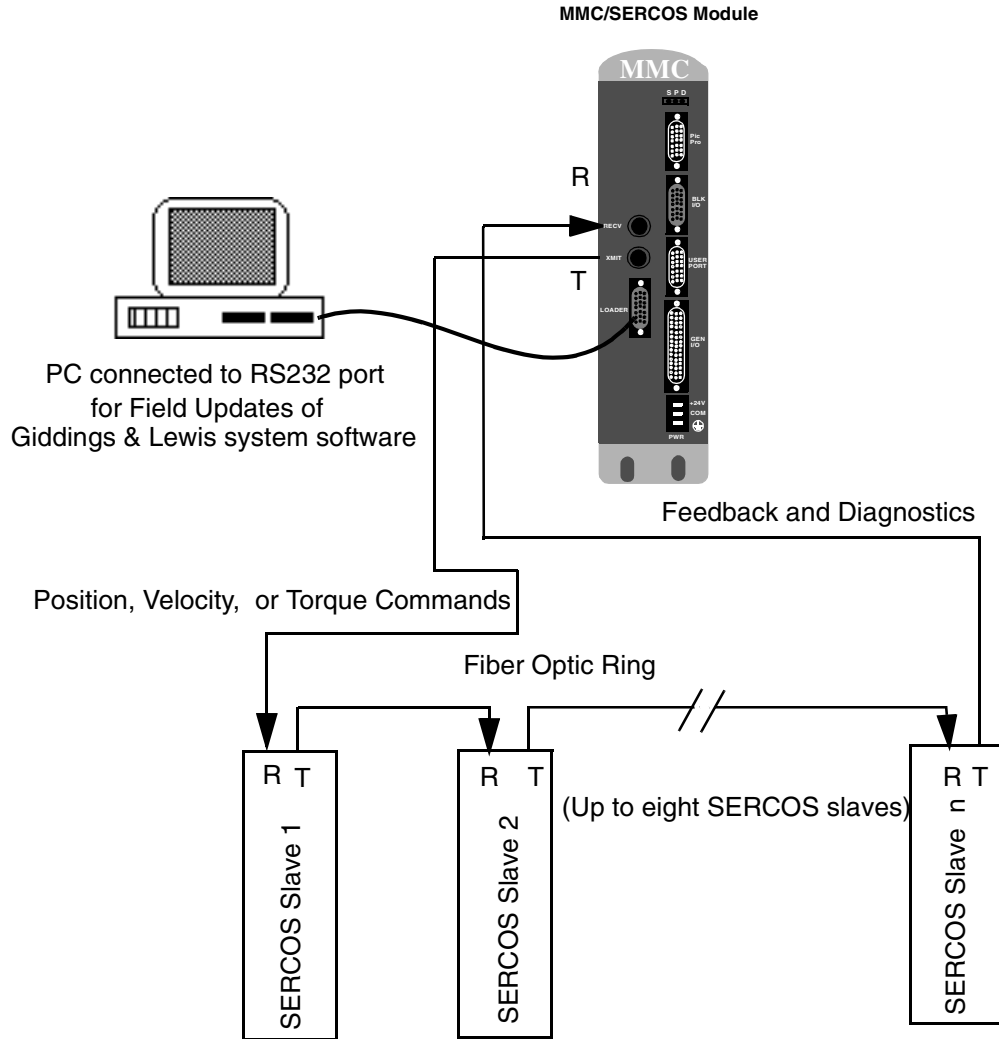

Table 3: SERCOS Fiber Optic Cables

| Description | Length | Part Number |
|------------------|-------------------|----------------------------------|
| Standard Cable | 1' | M.1016.9743 (old # 502-04170-01) |
| | 3' | M.1016.9744 (old # 502-04170-03) |
| | 5' | M.1016.9745 (old # 502-04170-05) |
| | 10' | M.1016.9747 (old # 502-04170-10) |
| | 15' | M.1016.9749 (old # 502-04170-15) |
| | 25' | M.1016.9753 (old # 502-04170-25) |
| | | |
| Heavy Duty Cable | .05 Meters (1.5') | M.0106.9758 (old # 502-04171-01) |
| | 1 Meter (3.3') | M.0106.9760 (old # 502-04171-03) |
| | 2 Meters (6.6') | M.0106.9763 (old # 502-04171-06) |
| | 3 Meters (9.9') | M.0106.9767 (old # 502-04171-10) |
| | 5 Meters (16.5') | M.0106.9773 (old # 502-04171-16) |
| | 10 Meters (32.5') | M.0106.9784 (old # 502-04171-32) |

11.2 Serial (Loader) Port

There is an RS232 serial port on the front of the module. This is used to connect to a PC in order to do a field update of the FLASH memory on the processor. The pinout is shown below.

Figure 23: Pinout for the 9-Pin D Connector

| Pin # | Signal Name | In/Out |
|-------|---------------|--------|
| 2 | Receive Data | In |
| 3 | Transmit Data | Out |
| 5 | Ground | In/Out |

12 Basic MMC Theory of Operation

12.1 Machine Control Board Operation

Figure 24: MMC Machine Control Board External Components

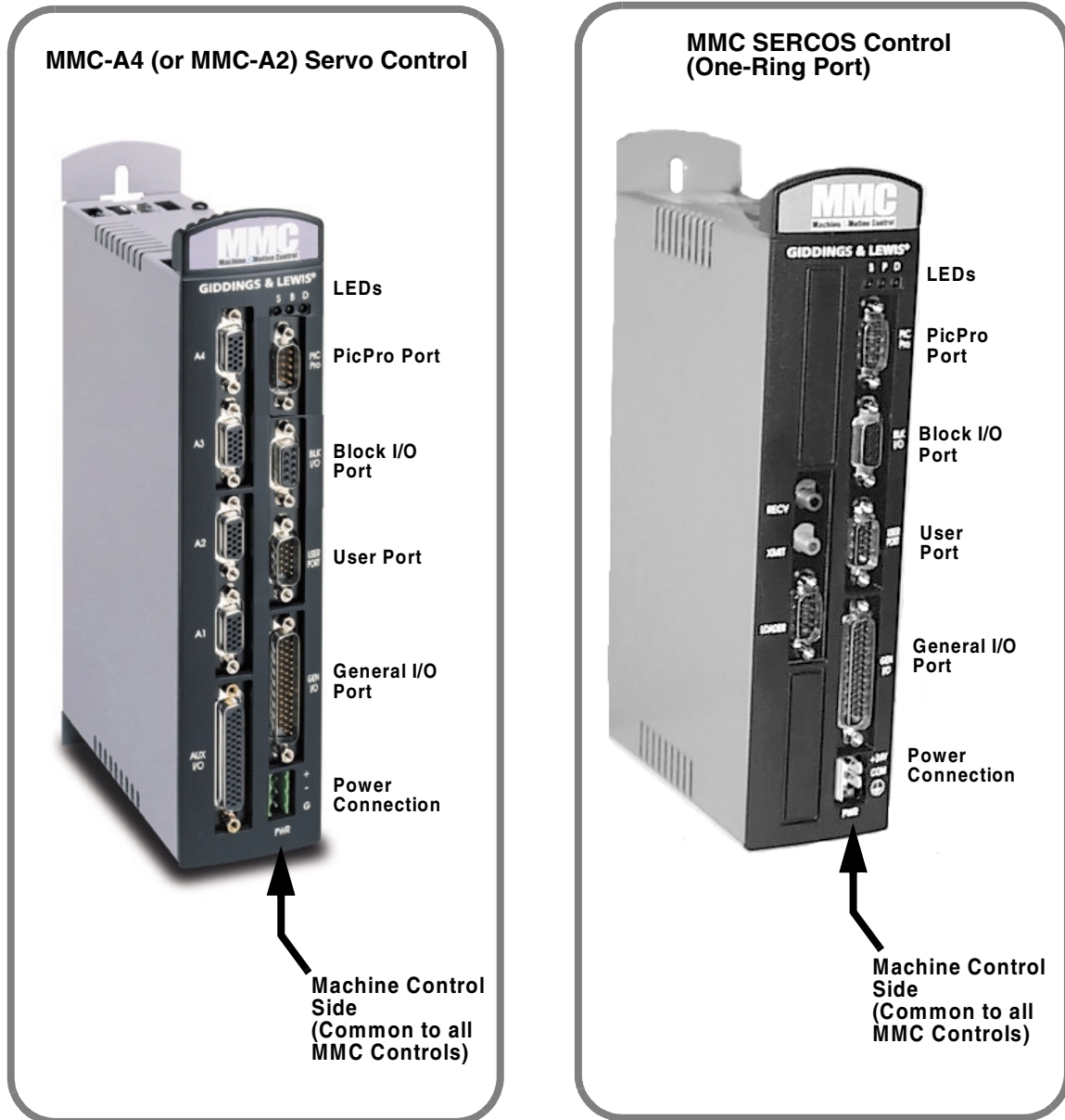

12.2 LEDs

There are three LEDs on the top of the CPU section of the MMC.

Figure 25: LEDs

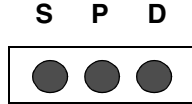

Below is a list of the LEDs and what they mean.

| | |
|--------------------------------|----------------------------------------------------------------------------------------------------------------------------------------|
| Scan (S) Green | |
| ON | The processor is executing the application program. |
| OFF | Scan is lost and there is an orderly shut down procedure followed. |
| Power/Battery (P) Green | |
| ON | Power is on to the system and the battery is OK. It indicates that the on-board +5 VDC supply is within tolerance. |
| OFF | Power is off. |
| Flashing | Power is on to the system (+5 V supply is OK) but the battery is bad. Replace lithium battery. See replacement procedure that follows. |
| Diagnostic (D) Yellow | |
| ON | On briefly during startup diagnostics. If it remains ON, module has failed startup diagnostics. |
| OFF | Normal operation |
| Flashing | Flashes error codes (listed below) under certain conditions. |

12.3 Diagnostic Error Codes

While the MMC is running, the DIAG LED on the CPU module will flash a three digit code signal if there is an error. For example, if there is a long pause-flash-pause-flash-flash-pause-flash-flash-flash-long pause, the code is 123. The errors are described below.

| Code | Error | Description |
|------|------------------------|----------------------------------------------------------------------------------------------------------------------------------------------------------------------------------------------------------------------------------------------------------------------------------------------------------------------------------------------------------------------------------------------------------------------------------------------------------------------------------------------|
| 123 | Scan too long | A ladder scan loss has occurred because the CPU takes more than 200 ms to scan the application program. Whenever the scan light is out, the discrete outputs go to the OFF state and the analog outputs are zeroed. |
| 124 | Excessive overhead | The system overhead update time is excessive. |
| 125 | Insufficient memory | There is insufficient memory on the CPU to run the current program. |
| 126 | No hardware bit memory | There is no bit memory installed on the CPU and the program requires it. |
| 127 | No software bit memory | There is no bit memory capability via software and the program requires it. |
| 222 | Driver error | No driver support on the CPU for the I/O module. Update your system EPROMs. |
| 22_ | Master rack error | The I/O modules in the master rack do not match what was declared in the hardware master declaration table. The number of flashes in the third digit () identifies the slot number that is in error. |
| 232 | Communications error | A failure has occurred in remote I/O communications. |
| 3_ _ | Expansion rack error | The I/O modules in the block I/O modules do not match what was declared in the expansion hardware declaration table. For block I/O modules: The number of flashes in the second and third digits indicates the block I/O module (01 through 77). The second digit will flash a 1 - 7, 10 for 0. The third digit will flash a 1 - 9, 10 for 0. For example, if the second digit flashes 3 times and the third digit flashes 10 times, the module is 30 . |

12.4 MMC Machine Control

The MMC converts input power into DC power at voltages of + 5V, + 15 V, and - 15 V and supplies them to the logic side of the system. The same supply that powers the MMC can be used for the fieldside of the system. Optionally, an external power supply (or supplies) can be used for the field side of the system. Such supplies are not routed through the MMC, but they should all have the same power cut-off switch as the MMC.

CAUTION

Always shut off power at the main disconnect switch before you begin to work on the MMC.

The MMC does the following:

- Performs diagnostic tests.
- Checks the battery.
- Performs routine maintenance tasks.
- Executes the application program.
- Communicates with the I/O.
- Maintains communication with the workstation through the PiCPro port.
- Maintains communication with the user interface device through the user port. (Details for this communication depend partly on the type of interface device. Refer to the manual that comes with the device.)
- Provides block I/O capability.

12.5 Application in Flash

The MMC has a flash chip on board that allows you to load an application program into it. This is standard on the MMC. Having the application in the standard flash chip ensures that you will not lose the application if the battery fails. On power up, the application is transferred from the flash chip to RAM as it is when directly downloaded from PiCPro.

To place the application in flash:

1. Compile the application into a hex file in PiCPro.
2. Use the Download Hex command in PiCPro to download the application into flash.

Even though you have placed an application in flash, you can still download and run a different application from PiCPro. However, when you cycle power on the MMC, the application in flash will always be placed into RAM.

12.6 General I/O Output Operation

Each of the 16 outputs on the general I/O connector is a solid state switch rated at .250 A. It turns on or off according to the logic state sent to it by the CPU. If the CPU sends it a logic 1, the switch closes and the device is powered. If the CPU sends a logic 0, the switch opens and power to the device is cut off. The CPU updates the logic state for each switch every time it scans the program.

The logic side of the switch is optically isolated from the field side. If you need to know whether voltage is actually present at the field side, use a voltmeter.

There are two groups of eight outputs: group A = output 1 through output 8, group B = output 9 through output 16. Each group is capable of detecting a short circuit condition. When a short circuit condition is sensed, all outputs in the group are turned off and remain off for approximately 100 ms regardless of ladder activity. After 100 ms, the ladder again controls the outputs. In addition, each output is protected with internal clamping diodes. Without clamping, high voltage transients (kickback) from inductive loads might damage the module.

12.7 Protecting from an Inductive Load

Resistive and inductive loads can be connected to the MMC General outputs and controlled by the system with no precautions other than making sure they have a connection to the common of the DC power supply.

Inductive loads have an electrical "kickback" when current is stopped. This can damage or destroy the output switching device. Each output has a diode through which reverse current can be safely routed.

The internal diode works with an inductive load. When an output is energized, represented by a closed switch, current passes through the load into the common line. When the output is de-energized, represented by an open switch, current stops and the inductive field collapses. The state of the outputs is controlled by the CPU. This creates a reverse voltage across the load called "kickback" which tries to continue the current. The voltage is in series with the DC power supply. The combined voltage appears across the output switching device in the module.

If this were the only path available, voltage across the device would peak at several hundred volts. The internal diode provides another path for current. This limits the peak reverse voltage across the load to less than 1 V. Every switch has this protection so you can connect an inductive load to any point.

Figure 26: Diagram of Internal Protection for Inductive Loads

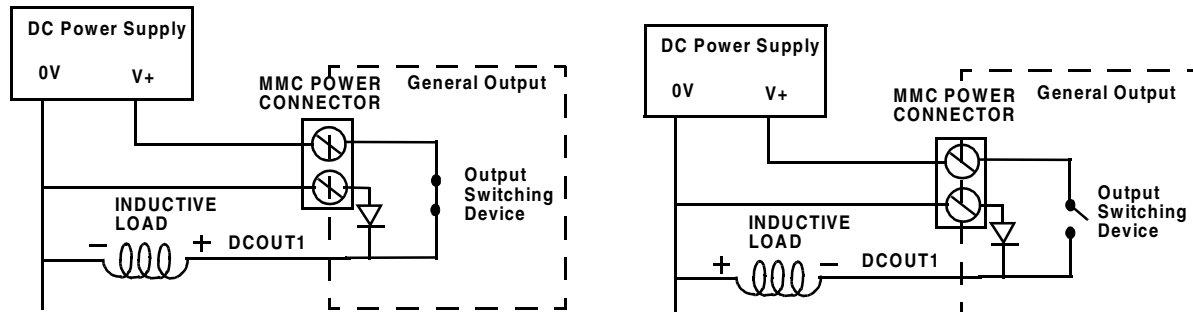

a) Output Energized

b) Output De-energized

12.8 DC Output Theory of Operation (Axis Connector)

Each axis output is an optically isolated solid state switch. It turns on or off according to the logic state sent to it by the CPU. When the switch turns on, current flows through the switch. When the switch turns off, current flow stops.

These outputs are intended to interface with the drive enable and drive reset inputs. When an output is turned on current can flow through the switch in either direction. This allows the outputs to be connected in a sink or source configuration.

For safety reasons, all outputs turn off (no current flow) when a scan loss condition occurs.

12.9 DC Input Operation (Axis, AUX, General Connectors)

Each input is guaranteed "on" at 14 to 30 VDC and guaranteed "off" at 0 to 5 VDC; polarity doesn't matter. Its on/off state is converted to a corresponding logic 1 or 0. This logic state is transmitted through the system bus to the CPU module, where the processor uses it as data in the ladder program. The logic side of the input is optically isolated from the field side.

The shaded blocks in Figure 27 shows the limits specified by the IEC. The lines show the maximum and minimum V/I of the inputs in this module. The voltage/current curve in this graph shows that the input module is well within the IEC Type 1 limits.

Figure 27: Input Characteristics Compared to IEC Standards

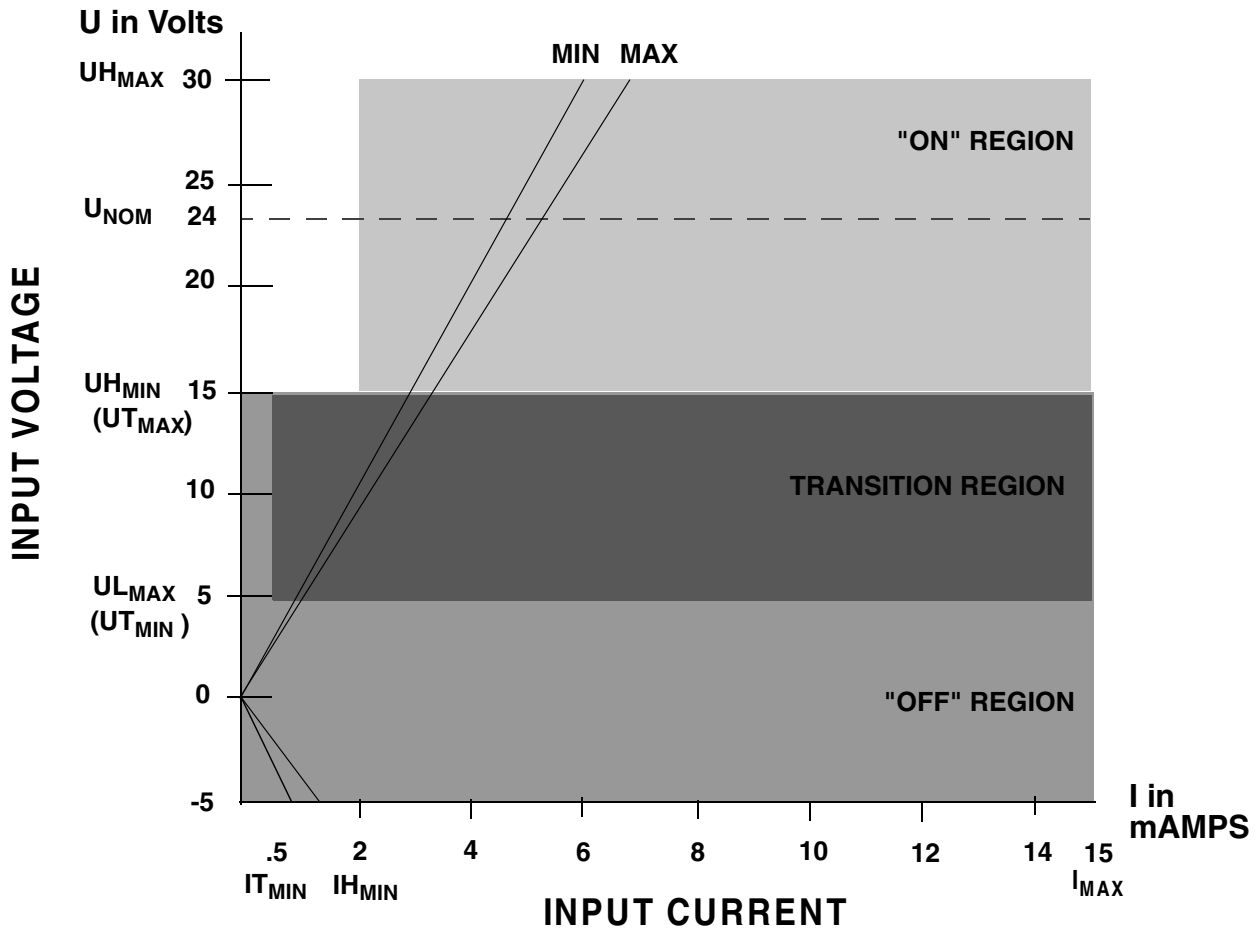

IMPORTANT

Switching devices can sometimes have a leakage current that exceeds the $I_{T_{min}}$ (current allowed when off) of an input module. In order to use such a device, an impedance (typically, a resistor) needs to be used in parallel with the input.

For example, some of the newer proximity switches use two wires instead of three. The third wire was used for a power or ground line. Without the third wire, the switch is easier to install. However, it requires more leakage current in the off state to power its internal circuitry.

As a conservative estimate, use the following formula to calculate an external resistance value. It keeps the input voltage at or below 2.4V when the switching device is in the "off" state.

$$\frac{2.4V}{\text{Switch Leakage} - 0.75mA} \geq R$$

If the switch leakage specification is ≤ 1.7 mA, then:

$$\frac{2.4V}{1.7 - 0.75mA} \geq 2.5K\Omega$$

Use a resistor less than or equal to 2.5 K Ω . Be sure that the wattage is adequate for the resistor when the switching device is in the "on" state remembering that:

$$P = \frac{V_{ON}^2}{R}$$

13 Analog Servo Control Operation

Figure 28: Locations of Input, Output, Encoder Pins on the MMC-A4 Unit

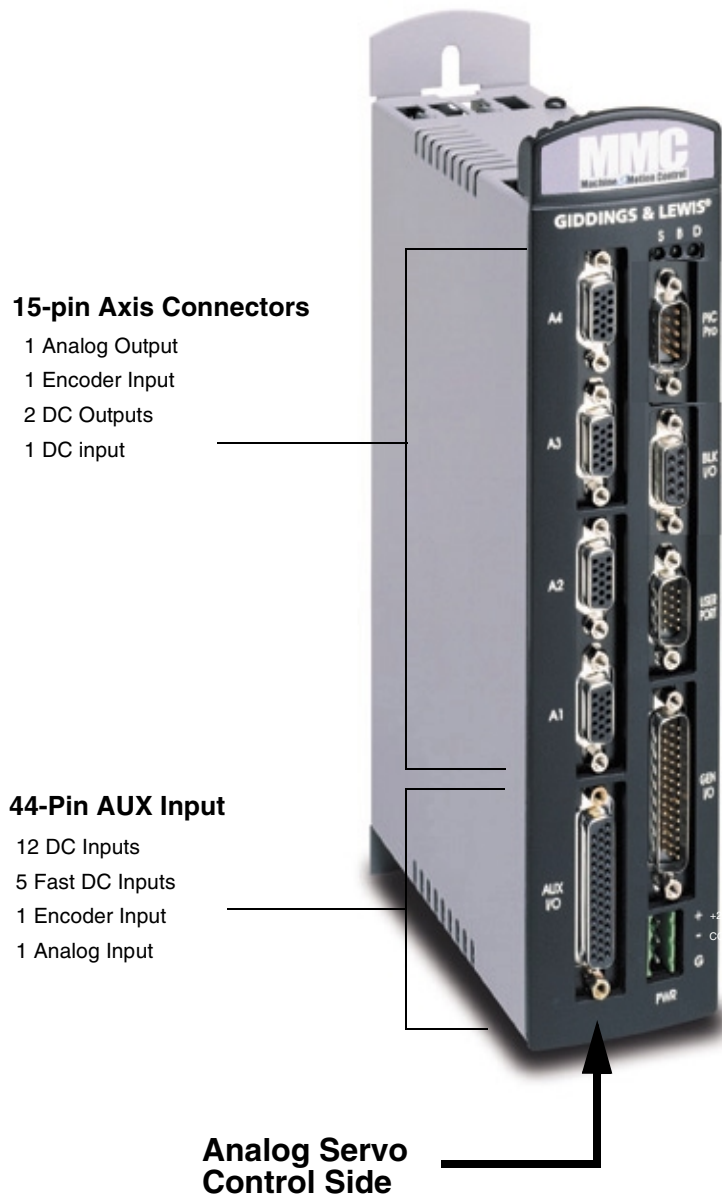

13.1 Analog Output Theory of Operation (Axis Connectors)

The CPU sends the analog output section a 16-bit digital word for each analog output channel used. Each digital word is converted to a corresponding voltage within the range of ± 10 V. The voltage is buffered and brought out to a pair of I/O connections as a differential type voltage output. This output is less subject to interference from electrical noise than a single-ended output would be.

You can adjust each analog output channel in software for offset adjustments, gain scaling, and unipolar outputs.

For safety reasons, all outputs are automatically reset to 0 V when a scan loss condition occurs.

13.2 Encoder Theory of Operation (Axis and AUX Connectors)

The encoder section uses differential type inputs to interface with up to five independent incremental encoders. These inputs accept RS422 level quadrature signals.

A *quadrature encoder* sends square wave type signals. When the shaft rotates at a constant velocity, the A and B outputs are square waves and are at the same frequency. However they are out of phase with each other by 90° . When the encoder shaft rotates in one direction, each A pulse leads the corresponding B pulse by 90° . When it rotates the other direction each A pulse lags its B pulse by 90° .

The signals illustrated in Figure 29 indicate that the encoder shaft rotates in one direction at first. Its speed of rotation decreases to 0 and then it starts rotating the other direction. The signals are shown as differential. \bar{A} is the inverse of the signal A and \bar{B} is the inverse of signal B.

Figure 29: Signals Transmitted by a Quadrature Encoder with Differential Outputs

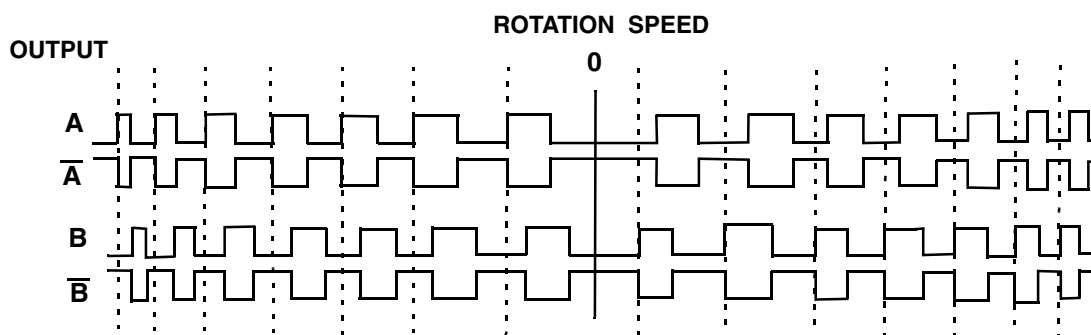

The maximum input frequency is 250,000 lines per second, which results in 1,000,000 Feedback Units (FUs) per second.

Figure 30: Counting Quadrature Pulses

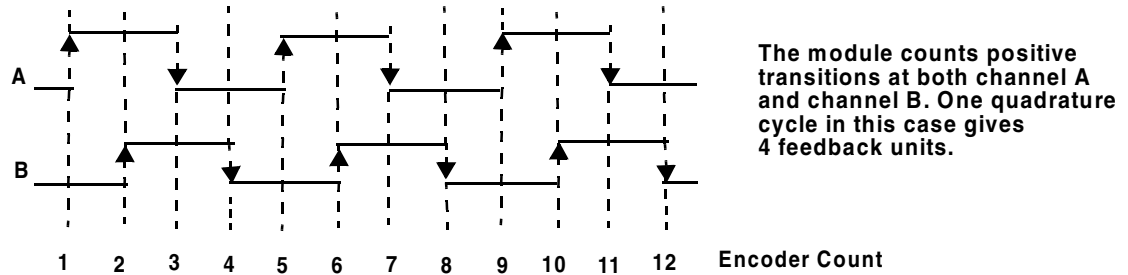

There is a 24-bit up/down counter for each channel. It is incremented or decremented on each A, B edge. There is also a 24-bit latch associated with each encoder channel.

The module can be programmed so that the counter value is "latched" or stored under one of these conditions:

- an index pulse from the encoder
- a positive or negative transition of the fast input
- the next index pulse after the required transition of the fast input

Each of the five 24-bit latches has a *fast 24 VDC input* associated with it. Each input is optically isolated. This input is intended to receive a signal from a device other than an encoder. It is typically used for referencing or synchronization purposes.

Fast input characteristics include:

- the detection of a signal occurs faster than it does for the DC inputs in other modules, due to less filtering. Because of this there is also less noise immunity.
- the response to a fast input signal is independent of ladder scan time. The module can be programmed to latch a position count as soon as this input is detected.

13.3 Analog Input Operation (AUX Connector)

There is one differential analog input channel on this module. The input range is ± 10 VDC. The analog input voltage is sampled every 100 μ sec by a 12-bit A/D converter. The most recent conversion result is stored in an on-board register. This register can be read at any time by the CPU.

The analog input signal passes through a common mode and differential mode filter prior to being applied to the A/D converter. These filters improve the noise immunity of the module.

14 MMC SERCOS Control Operation

The MMC SERCOS board is an alternate type of motion control used as part of an MMC base unit. It provides an interface between the MMC and a fiber optic ring. A ring can have from one to eight SERCOS slaves. The module contains an on board processor. There is one SERCOS ring port located at the center of the module. This ring port has a receive and a transmit fiber optic connector. There is also an RS232 port used for loading FLASH memory updates.

The SERCOS board is controlled by an LDO created in PiCPro. An on-board processor interprets the functions and performs appropriate operations according to the SERCOS communications protocol.

The data transfer rate is 4M Baud with user-defined update rate.

If a scan loss occurs, SERCOS communications are reset. There is no communication with the SERCOS slaves until you reinitialize.

Figure 31: Location of the SERCOS Ring Port on the MMC SERCOS Control

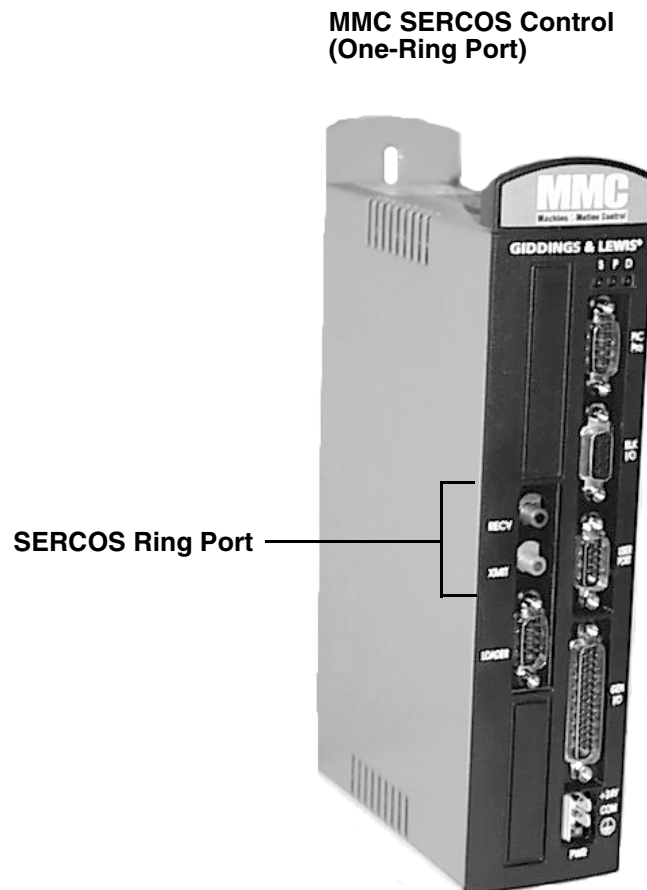

NOTES

15 Replacing the MMC Battery

Follow the procedure below to replace the MMC battery when the "P" LED is flashing.

1. After DC power has been applied to the MMC for at least five minutes, turn off power. This ensures that the contents of memory will not be lost while the battery is removed. Disconnect the input power connector from the MMC.
2. Remove the MMC (including any optional modules) from the cabinet.
3. Use a static-free work surface if possible. Ground yourself using a properly grounded wrist strap before you open the case. These are standard precautions before handling any electronics component.
4. Lay the MMC system on the work surface. If there are no optional modules attached, remove the cover by removing the five screws , two on top, two on the bottom, and one on the right side of the MMC.
If there are one or more optional modules attached, remove the four screws that attach the first optional module and remove the MMC from the optional modules.

| WARNING |
|-----------------------------------------------------------------------------------------------------------------------------------------------------|
| DO NOT touch any of the capacitors. Do not touch the pins on any of the ICs; even with precautions against static you may destroy the circuitry. |

5. Use Figure 32 to locate the battery. Note how it is oriented.

Figure 32: Battery Location in MMC

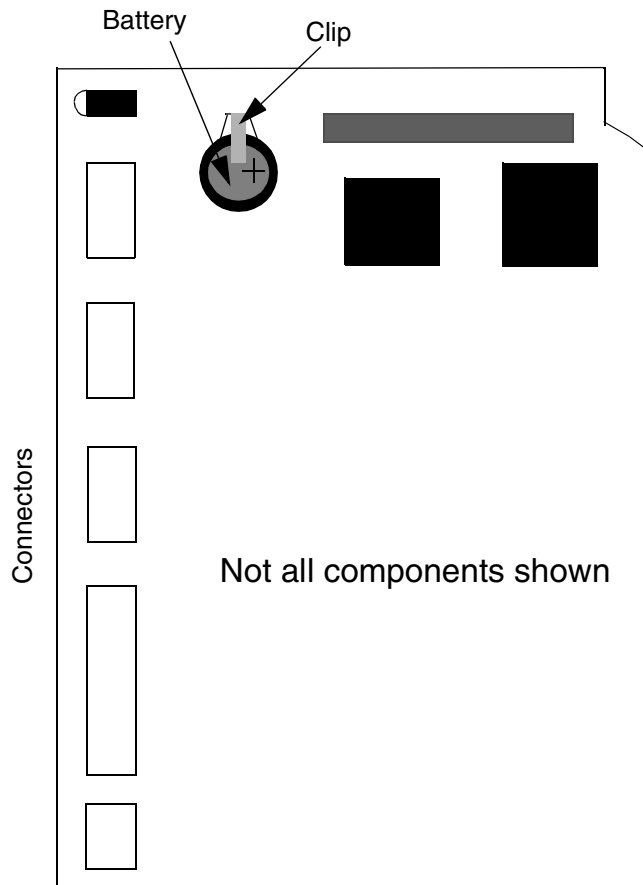

6. Use a screwdriver to gently pry up the battery clip. Slide the battery out. Replace it with a 3V coin cell, BR2032 battery, + side up.
7. Screw the cover or optional modules back on. Return the MMC to the cabinet. Connect the power cable. Turn on power and check the LEDs.

16 Specifications

| General | | | | | | | | | | | |
|----------------|-------------------------------------|--------------------|---------|---------|----------|-----------------------------------------------------|------|------|------|-------|--------|
| Characteristic | | MMC Specifications | | | | | | | | | |
| | | | | | | Number of servo axes available at six update rates* | | | | | |
| Model | Part Number | Speed | App Mem | RAM Mem | User Mem | 8 ms | 4 ms | 2 ms | 1 ms | .5 ms | .25 ms |
| MMC-A2 | M.1017.3772 (old # 503-26606-21) | 32 MHz | 256K | 128K | 64K | 2 | 2 | 2 | 2 | 2 | 1 |
| MMC-A4 | M.1017.3774 (old # 503-26606-41) | 32 MHz | 256K | 128K | 64K | 4 | 4 | 4 | 4 | 2 | 1 |
| MMC-S8 | M.1017.3770 (old # 503-26606-00) | 32 MHz | 256K | 128K | 64k | 8 | 8 | 4 | 4 | 2 | 1 |

*Consult Giddings & Lewis for assistance if you want to exceed the number of axes in this chart.

| | |
|---------------------------------------------------------------------------------------------------------------------------------------------------------------------------------------------------------------------------------------------------------------------------|------------------------------------------------------------------------------------------------------------|
| CPU | 32 bit RISC processor with numeric coprocessor |
| Battery | 3V Coin Cell, BR2032 lithium battery |
| <p>CAUTION for Lithium Batteries Danger of explosion if battery is incorrectly replaced. Replace only with the same or equivalent type recommended by the manufacturer. Dispose of used batteries according to the manufacturer's instructions.</p> | |
| Flash Disk | 2 Megabytes |
| Memory | 1 Megabyte max. |
| PiCPro Port (to workstation) | RS232 serial port, secured protocol Software selectable baud rate to 57.6K |
| User Port (to serial interface device) | RS232/RS485 serial port Supports RTS/CTS hardware handshaking Software selectable baud rate to 19.2K |
| Input voltage | 20 VDC to 30 VDC |
| Input power | 250 mA plus I/O power |

Specifications

| | |
|-----------------------------|----------------------------------------------------------------------------------------------------------------------------------------------------------------------------------------------------------------------------------------------------------------------------------------------------------------------------------------------------------------------------------------------------------------------------------------------------------------------------------------------------------------------------------------------------------------------------------------------------------------------------------------------------------------------------------------------------|
| Time-of-day clock | Access via PiCPro 10.2 and above or your application program |
| Clock tolerance | At 25°C (77°F), ±1 second per day Over temperature, voltage and aging variation, +2/-12 seconds per day |
| Operating temperature range | 5°C to 55°C (41°F to 131°F) |
| Storage temperature range | -40°C to 85°C (-40°F to 185°F) |
| Humidity | 5 to 95%, non-condensing |
| CE Marked | Conforms to Directives 73/23/EEC, 89/336/EEC, 92/31/EEC, 93/68/EEC by conforming to the following standards: EN 50081-2:1993 EMC Generic Industrial Emissions EN 50082-2:1995 EMC Generic Industrial Immunity EN 61131-2:1994/A11:1996 Low voltage directive requirements for programmable controllers Operates with emissions below EN55011/ CISPR 11 Class A limits Immune to: •Electrostatic discharge (4K V contact mode, 8K V air discharge) per EN61000-4-2 •RF electromagnetic fields per EN61000-4-3, ENV 50141, and ENV50204 •Electrical fast transients per EN61000-4-4 •Magnetic fields per EN61000-4-8 Refer to the EMC Guidelines for more information. |
| UL and C/UL Listed | E126417 |
| Physical size | 2.25" wide x 9.6" high x 5.3" deep 57.15 mm x 243.84 mm x 134.62 mm |
| Vibration (per IEC 68-2-6) | 10-57 Hz (constant amplitude .15 mm) 57 - 2000 Hz (acceleration 2 g) |
| Shock (per IEC 68-2-27) | Four shocks per axis (15g/11 msec) |

Specifications

| Analog Output | |
|-------------------------------------------|-------------------------------------------------------|
| Output channels | 2 or 4 |
| Resolution | 16 bits |
| Output voltage range | ± 10 VDC |
| Maximum output current (1K Ω load) | ± 10 mA |
| Power on output voltage | 0 V ± 100 mV |
| Scan loss output voltage | 0V ± 100 mV |
| Accuracy | $\pm 0.375\%$ of FSR Drift ± 50 ppm/ $^{\circ}$ C |
| Update rate | 68 μ sec |
| Analog Input | |
| Input channel | 1 |
| Resolution | 12 bits |
| Input voltage range | ± 10 V |
| Accuracy | $\pm 0.2\%$ of FSR |
| Sample rate | 100 μ sec |
| Common mode filter | 3 dB @ 10 K Hz |
| Differential mode filter | 3 dB @ 475 Hz |

| Encoder Input | |
|----------------------------------------------|---------------------------------------------------------------------------------------------------------------------------------------------------------------------------------------------------------------------------------------------------------------------------------------------------------------------------------------------------------------------------------------|
| Input channels | 3 or 5 |
| Input receiver type | 2632 differential RS422 type receiver |
| Encoder signals | Differential quadrature |
| Input threshold | ±750 mV |
| Input termination | 120 $\frac{3}{4}$ |
| Maximum input voltage | 5 V |
| Maximum A or B input frequency | 250 K Hz (1 M feedback unit count rate) |
| Fast input voltage | Nominal 24 VDC, maximum 30 VDC |
| Guaranteed on voltage | 15 VDC |
| Guaranteed off voltage | 5 VDC |
| Turn on/off time | 1 ms |
| General, Auxiliary and Axis DC Inputs | |
| Configuration | The general inputs are divided into two groups of eight. Each group can be configured for sourcing or sinking. The auxiliary inputs are divided into two groups of six inputs. Each group can be configured for sourcing or sinking. The axis inputs have one input per axis. Each input can be configured for sourcing or sinking. Operates with IEC Type 1 inputs (per IEC 1131=2). |
| Input voltage | Nominal 24 VDC, maximum 30 VDC |
| Guaranteed on voltage | 15 VDC |
| Guaranteed off voltage | 5 VDC |
| Turn on/off time | 1 ms |
| Fast inputs | 50 μ sec |

| General DC Outputs | |
|-----------------------------------------|----------------------------------------------------------------------------------------------------------------------------------|
| Number of outputs | 16 outputs |
| Input voltage | Nominal 24 VDC, 30 VDC maximum |
| Configuration | Two groups of eight solid-state switches. |
| Protection of logic circuits | Optical isolation between the logic and field side, transient suppression on the 24V external supply |
| Maximum current | .25 A per output |
| Voltage range | 24 VDC nominal, 5 to 30 VDC |
| Switch characteristics | Solid-state switches |
| Time delay on for resistive loads | 50 μ sec max |
| Time delay off for resistive loads | 50 μ sec max |
| Leakage current in off state | 0.5 mA max |
| Switch voltage, maximum ON | 1 VDC max |
| Short circuit protection for each group | 15 A (max) pulses for about 130 μ sec every 100 msec until short is removed |
| Scan loss response | Outputs turn off |
| Axis DC Outputs | |
| Number of outputs | 2 outputs per axis |
| Configuration | Each set of axis outputs can be configured as sourcing or sinking. |
| Maximum current | 100 mA per output |
| Voltage range | 24 VDC nominal, 5 to 30 VDC range |
| Scan loss response | Outputs turn off |
| Auxiliary DC Output | |
| +5 VDC | 150 mA maximum current available. Connections to this point should be over short distances and away from electric noise signals. |

| SERCOS | |
|---------------------------------|------------------------------------------------------------------------------------------------------------------------------------------------------------------------------------------------------------------------------------------------------------------------------------------------------------------------------------------------------------------------------------------------|
| SERCOS Interface | Interfaces with one ring with from one to eight digital drives |
| SERCOS port | SMA female connectors for interfacing to 1000 μ meter plastic fiber optic cable with SMA male connectors. Fiber optic receiver specifications: Peak input power (optical level low) -31.2dBm max Peak input power (optical level high) -20.0 dBm min, 0.0dBm max Fiber optic transmitter specifications: Peak output power (optical level high) -10.5 dBm min, -5.5 dBm max |
| Update loader port | RS232 interface |
| Type | Plastic with step index profile (POF) |
| Core diameter Fiber diameter | 980 μ m \pm 60 μ m 1000 μ m \pm 60 μ m |
| Operating temperature | 0° C to 55° C (32° F to 131° F) |
| Minimum bend radius | One time: 30 mm Continuous: 80 mm |
| Tensile strength | One time: 250 N Continuous: 100 N |
| Connectors | SMA style male |

A.1 - MMC Ethernet™ TCP/IP Module

1 Introduction

The ETHERNET - TCP/IP module provides the MMC with Ethernet access and Internet connectivity. A 10Base T connection is provided following the IEEE 802.3 specification. The data transfer rate is 10 Mbps. Applications can range from connecting several MMCs, connecting groups of MMCs and PCs, or connecting to a system that includes Internet access.

At the end of this document is a partial list of Internet links to useful information about Ethernet and TCP/IP networking.

The Remote Programmer Access switch (future feature) will allow you to enable/disable MMCPPro for Windows running over Ethernet. The DIAG LED goes on briefly while the diagnostic tests are running shortly after power is applied.

Figure A.1-1. MMC Ethernet - TCP/IP Module

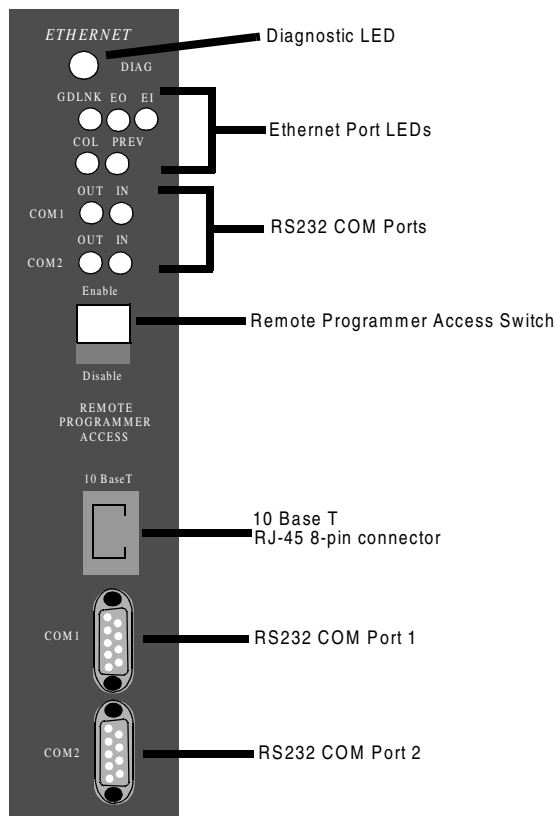

2 Connections

The MMCPro cable is used to make a connection between the PC and the MMC.

1. Connect the PC to the RS232 Com 2 Port on the Ethernet - TCP/IP module to download the TCP/IP configuration file.
2. Connect the PC to the PiCPro Port on the CPU to download the application LDO.

Figure A.1-2. MMC/PC Connections

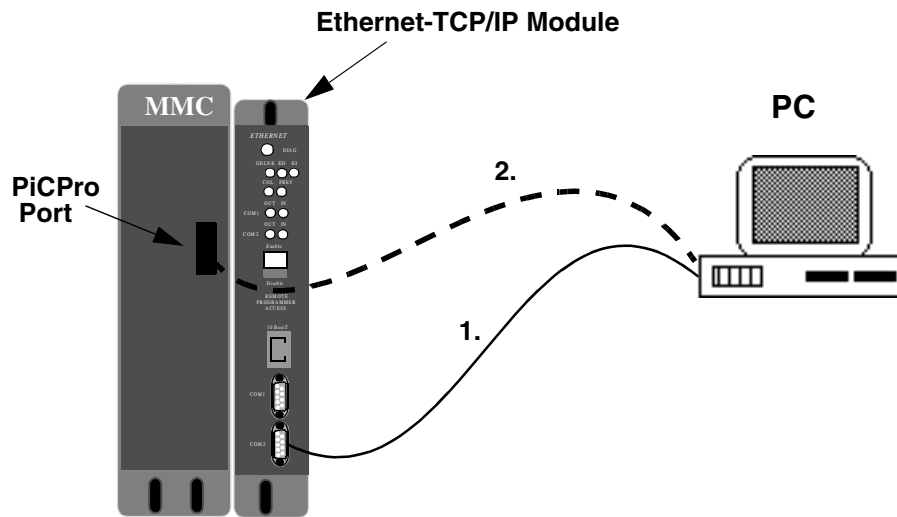

You will use 10Base T (10 Mbps, baseband, over twisted pair cable) to set up your Ethernet - TCP/IP system.

The table below summarizes the specifications (IEEE 802.3) for the Ethernet connection available on the MMC Ethernet - TCP/IP module.

| | Connections |
|-------------------------------------|------------------------------------------------------------------------------------------------------------|
| | 10Base T |
| Type of Cable | Category 3 or 5 (5 recommended) UTP (unshielded twisted-pair) Shielded category 5 cable is optional. |
| Connection | RJ-45 |
| Topology | Star |
| Distance | 100 m (328') between transceiver (TCP/IP module) and hub |
| Maximum cable segment length | 100 m (328') |
| Data Rate | 100 Mb/s |

A typical MMCal 10Base T connection is shown below.

Figure A.1-3. Ethernet - TCP/IP 10Base T Connections

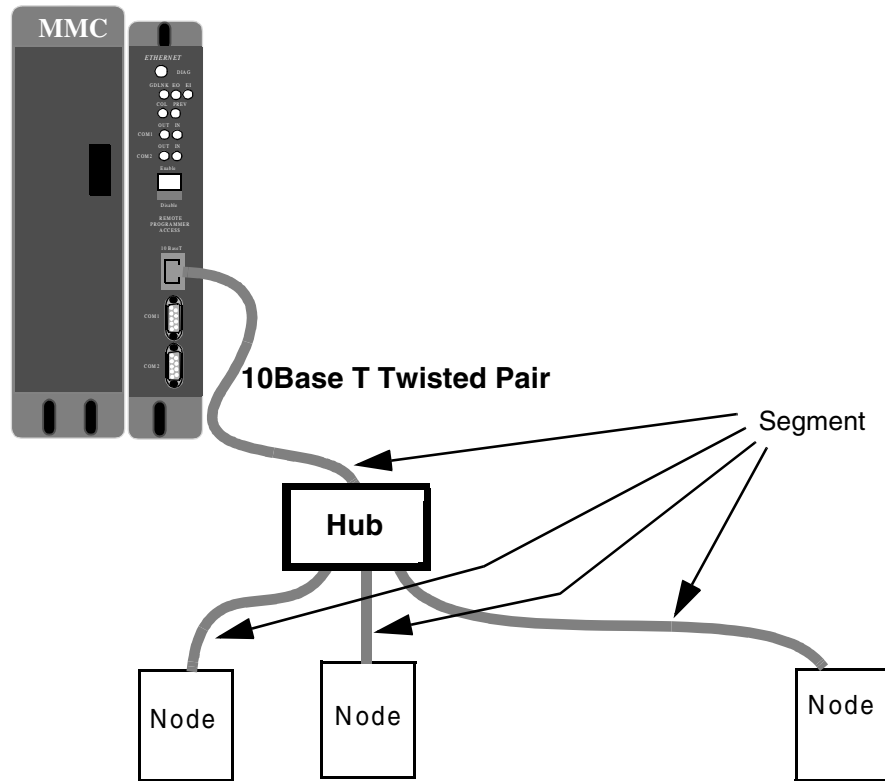

Maximum segment length is 100 m (328').

2.1 The Ethernet Port

The 10Base-T port uses a RJ-45 style 8-pin connector using 100 ¾ unshielded twisted pair category 3 or 5 cable (IEEE 802.3 section 14.4). The maximum length of the twisted pair cable segment is 100 m (328 ft.). NOTE: The connector is also suitable for shielded cable and will ground the shield to the chassis.

2.2 The RS232 COMM Ports

There are two RS232 ports at the top of the module as shown in Figure 4-3. COMM 1 will be used for modem connections (future). COMM 2 is used to download your configuration file to the MMC.

| Pin # | Signal Name | |
|-------|---------------|-----|
| 2 | Receive Data | RX |
| 3 | Transmit Data | TX |
| 5 | Ground | Gnd |
| 7 | Ready to send | RTS |
| 8 | Clear to send | CTS |
| Shell | Chasis gnd | |

3 LEDs

There are nine LEDs on the MMC Ethernet - TCP/IP module in addition to the DIAG LED. They are located directly under the DIAG LED as shown below.

Figure A.1-4. Ethernet - TCP/IP LEDs

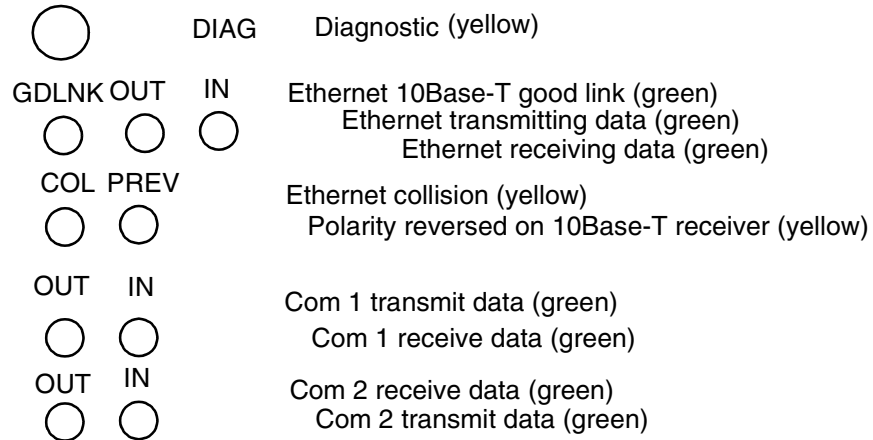

4 Firmware Update

For this release, the firmware required for using the MMC Ethernet-TCP/IP module must be dated 7/99 or newer. After you open PiCPro for Windows on your PC and before you open any file, check the date on your MMC EPROM by using the Online, Status menu item in PiCPro. The first item listed in the Communications Status box is the "Control EPROM version". If this is dated prior to 7/99, you will need to download the MMC01.hex file included on the CD you received. Use the PiCPro Online, Download hex command.

When the Download Hex box appears, follow these steps:

1. Using the Browse button, locate the MMC01.hex file.
2. Click on the appropriate baud rate.
3. Be sure the PiCPro port is selected.
4. Click on Start to begin downloading the hex file. Follow the prompts. They will tell you to turn the control off and then back on.

A status bar shows the progress of the download. If an error occurs, it will be reported in the Information Window.

5 Theory of operation

The MMCEthernet - TCP/IP module contains a 32-bit processor to handle TCP/IP, PPP (future), and Ethernet protocols. It allows you to use the Ethernet network architecture and the TCP/IP standard set of protocols to communicate and access other modules, computers, or the Internet and its resources. The design is based on the IEEE 802.3 specifications. The data rate is 10 Mbps. The diagram below provides an overview.

Figure A.1-5. MMC Ethernet - TCP/IP Overview

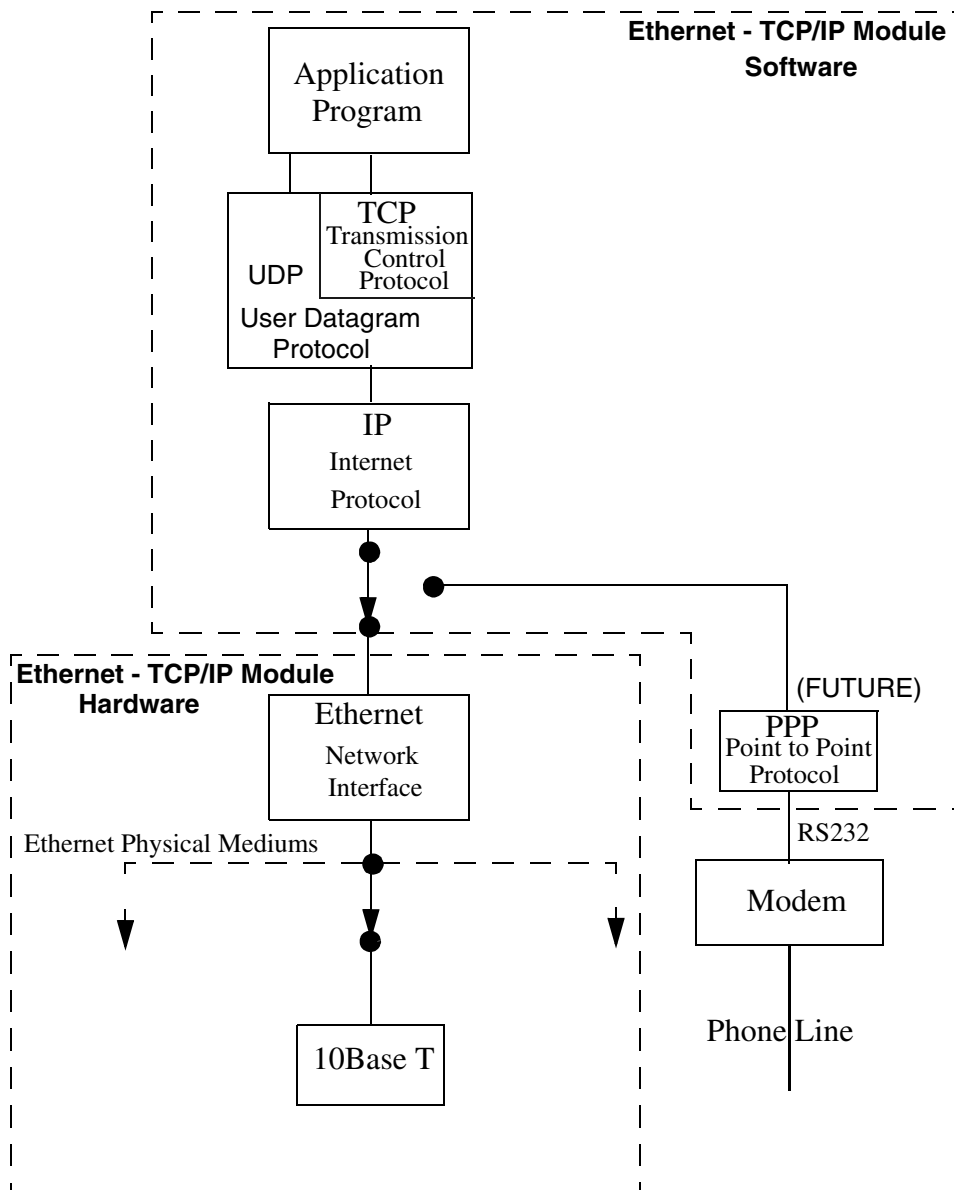

6 Specifications Table

| Characteristics | Ethernet - TCP/IP Module Specifications |
|-----------------------------|--------------------------------------------------------------------------------------------------------------------------------------------------------------------------------------------------------------------------------------------------------------------------------------------------------------------------------------------------------------------------------------------------------------------------------------------------------------------------------------------------------------------------------------------------------------------------------------------------------------------------------------------------------------------------------------------------------------------------------------------------------------------------------------------------------------------------------------------|
| Function | Provides the MMC with Ethernet access and Internet connectivity |
| Part number | M.1017.3888 (old # 503-26683-01) |
| RS232 Port 1 | Com Port 1 modem (future) |
| RS232 Port 2 | Com Port 2 (for firmware and configuration loading) |
| 10Base T | RJ-45 8-pin connector Maximum twisted pair length is 100 m (328 ft.). |
| 24 VDC Power from the MMC | 200 mA |
| Operating temperature range | 7° C to 55° C (45° F to 131° F) |
| Storage temperature range | -40° C to 85° C (-40° F to 185° F) |
| Humidity | 5 to 95%, non-condensing |
| CE Marked (Pending) | <p>Conforms to Directives 73/23/EEC, 89/336/EEC, 92/31/EEC, 93/68/EEC by conforming to the following standards:</p> <p>EN 50081-2:1993 EMC Generic Industrial Emissions EN 50082-2:1995 EMC Generic Industrial Immunity EN 61131-2:1994/A11:1996 Low voltage directive requirements for programmable controllers</p> <p>Operates with emissions below EN55011/ CISPR 11 Class A limits</p> <p>Immune to:</p> <ul style="list-style-type: none"> • Electrostatic discharge (4K V contact mode, 8K V air discharge) per EN61000-4-2 • RF electromagnetic fields per EN61000-4-3, ENV 50141, and ENV50204 • Electrical fast transients per EN61000-4-4 • Magnetic fields per EN61000-4-8 <p>Refer to the EMC Guidelines for more information.</p> |
| UL and C/UL Listed | In process |
| Physical size | 1.3" wide x 9.6" high x 5.3" deep 33 mm x 244 mm x 135 mm |
| Vibration (per IEC 68-2-6) | 10-57 Hz (constant amplitude .15 mm) 57 - 2000 Hz (acceleration 2 g) |
| Shock (per IEC 68-2-27) | Four shocks per axis (15g/11 msec) |

7 Useful Internet Links

http://www.3com.com/technology/tech_net/white_papers/500698.html#6

<http://www.library.ucg.ie/Connected/Course/index.htm>

<http://www.combsnet.com/cable/Basics/types.html>

http://www.jdltech.com/solutions/Standards_Terms.cfm

http://www.jdltech.com/solutions/LAN_terms.cfm

http://www.datatech.com/hot/w96_2.htm

<http://www.standards.ieee.org/catalog/IEEE802.3.html>

<http://www.3com.com/nsc/glossary/main.htm>

http://www.alliedtelesyn.com/prd_tran.htm#microtrans

http://www.lothlorien.net/collections/computer/ethernet_frames.html

<http://www.lantronix.com/htmlfiles/mrktg/catalog/etntba.htm>

<http://www.warehouse.com/datacomm/>

B.1 - MMC DeviceNet™ Module

1 Introduction

The MMC DeviceNet™ scanner module is an interface between the MMC and a DeviceNet network. The module contains an on-board processor, a DeviceNet compliant interface, and firmware that makes it act as the master to all other nodes on the network.

Prior to initial operation, a file is generated with specific configuration software in an external PC. This file must be downloaded via the RS232 configuration port to the DeviceNet module prior to initial operation. Two indicator LEDs (IN/OUT) are connected to this configuration port.

Directly above the DeviceNet port are two LEDs that provide operation information: Network Status and DeviceNet Scanner Status.

The DIAG LED goes on briefly while the diagnostic tests are running.

Figure B1-1. MMC DeviceNet Module

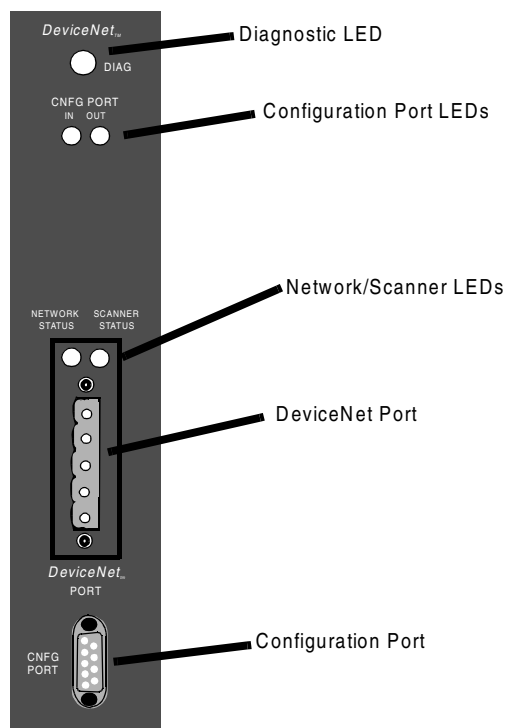

2 Connections

DeviceNet connections are illustrated in Figure B1-2. Up to 63 DeviceNet Nodes may be attached to the DeviceNet scanner module.

Figure B1-2. DeviceNet Connections

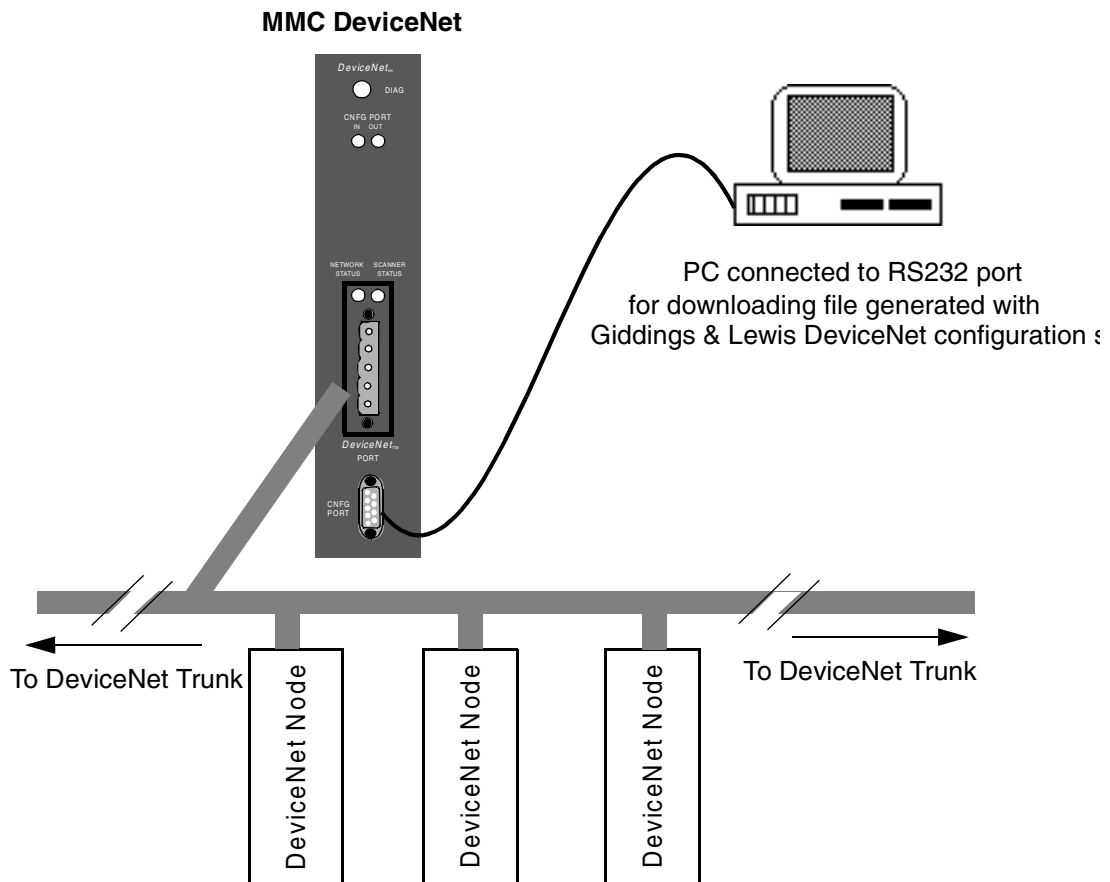

2.1 The DeviceNet Port

The DeviceNet port is on the front of the module near the center as shown in Figure B1-1. The pinout for the DeviceNet port is shown below:

| Pin # | Signal Name | Standard Wire Colors |
|-------|----------------|----------------------|
| 1 | V- | black |
| 2 | CAN_L | blue |
| 3 | Shield (drain) | bare |
| 4 | CAN_H | white |
| 5 | V+ | red |

In your network layout, follow DeviceNet specifications. Only use DeviceNet compliant cable, such as Belden 3084A thin wire and Belden 3082A thick wire.

2.2 The Configuration (RS232) Port

There is an RS232 port on the lower front of the module as shown in Figure B1-1. This is used to connect to a PC in order to download a file representing your DeviceNet network.

| Pin # | Signal Name | In/Out |
|-------|---------------|--------|
| 2 | Receive Data | In |
| 3 | Transmit Data | Out |
| 5 | Ground | In/Out |

3 LEDs

The two configuration port LEDs and the two DeviceNet port LEDs are described below.

| | LED | Color | State | Definition | |
|--------------------|----------------|--------|------------|------------------------------------------------------------------------------|-----------------------------------------------------------|
| DeviceNet Port | Network status | None | OFF | Off-line | |
| | | Green | ON | On-line and connected to at least one node | |
| | | | Flashing | On-line but connection nodes not established | |
| | | Red | ON | Unrecoverable Fault (duplicate MAC ID check failed, critical bus fault etc.) | |
| | | | Flashing | I/O connections in timed-out state or other Recoverable Fault | |
| | Scanner status | Green | OFF | | No power or else reset asserted |
| | | | ON | | Scanner OK and active |
| | | | Flashing | | Scanner OK but not active |
| | | Red | ON | | Hardware or software error |
| | | | Flashing | | Recoverable configuration error (invalid data downloaded) |
| | | Orange | ON | | Configuration (download) mode |
| Configuration Port | IN | Red | Flickering | Data is being passed to the module | |
| | | | OFF | No data to the module | |
| | OUT | Red | Flickering | Data is being passed from the module | |
| | | | OFF | No data from the module | |

4 Theory of Operation

The DeviceNet scanner module provides a memory image of the nodes (slaves) connected to a DeviceNet network. It is this memory image that is controlled by your LDO created in PiCPro. The module's on-board processor continually transfers data between this memory image and the actual DeviceNet nodes.

Communication between the DeviceNet module and the nodes can be set at 125 Kbaud, 250 Kbaud, or 500 Kbaud. The baud rate, the relationship between the memory image and specific data in each node, and other parameters are established with configuration software run in an external PC.

This configuration software generates two files. One file is downloaded to the DeviceNet module through its RS232 serial port. The other file is used by PiCPro to establish the relationship between the memory image and the declared variables in the LDO. To ensure that a given location in the memory image is connected to a variable in the LDO and to the corresponding data in the DeviceNet node, the same tag name or label must be used.

For example, when running the configuration software, PROX_SW1 could be used as the name for the boolean bit representing a DeviceNet proximity switch's logic state. The name PROX_SW1 must also be used for the corresponding variable in your LDO.

NOTE

The G&L DeviceNet configuration software (G&L Part No. M.1017.4267) is required to configure the DeviceNet scanner (within the DeviceNet module) for the devices on the associated network.

NOTE

Additional information about DeviceNet can be obtained from www.odva.org.

5 Specifications

| Characteristics | DeviceNet Module Specifications |
|-----------------------------|------------------------------------------------------------------------------------------------------------------------------------------------------------------------------------------------------------------------------------------------------------------------------------------------------------------------------------------------------------------------------------------------------------------------------------------------------------------------------------------------------------------------------------------------------------------------------------------------------------------------------------------------------------------------------------------------------------------------------------------------------------------------------------------------------------------------|
| Function | Interfaces to a DeviceNet network with up to 63 other nodes |
| Part number | M.1017.3889 (old # 503-26684-00) |
| DeviceNet Port | Phoenix style 5-pin male connector |
| Configuration Port | RS232 interface |
| 24 V DC Power from the MMC | 100 mA |
| Operating temperature range | 7° C to 55° C (45° F to 131° F) |
| Storage temperature range | -40° C to 85° C (-40° F to 185° F) |
| Humidity | 5 to 95%, non-condensing |
| CE Marked | <p>Conforms to Directives 73/23/EEC, 89/336/EEC, 92/31/EEC, 93/68/EEC by conforming to the following standards:</p> <p>EN 50081-2:1993 EMC Generic Industrial Emissions EN 50082-2:1995 EMC Generic Industrial Immunity EN 61131-2:1994/A11:1996 Low voltage directive requirements for programmable controllers</p> <p>Operates with emissions below EN55011/ CISPR 11 Class A limits</p> <p>Immune to:</p> <ul style="list-style-type: none"> • Electrostatic discharge (4K V contact mode, 8K V air discharge) per EN61000-4-2 • RF electromagnetic fields per EN61000-4-3, ENV 50141, and ENV50204 • Electrical fast transients per EN61000-4-4 • Magnetic fields per EN61000-4-8 <p>Refer to the EMC Guidelines for more information.</p> |
| UL and C/UL Listed | File No. E126417 NRAQ Programmable Controllers |
| Physical size | 1.3" wide x 9.6" high x 5.3" deep 33 mm x 244 mm x 135 mm |
| Vibration (per IEC 68-2-6) | 10-57 Hz (constant amplitude .15 mm) 57 - 2000 Hz (acceleration 2 g) |
| Shock (per IEC 68-2-27) | Four shocks per axis (15g/11 msec) |

C.1 - Breakout Boxes, Centurion Connector Cables and Flying Lead Cables

There are various plug and play connection products available for field wiring of the MMC control. These include Breakout Boxes with appropriate cable, Centurion MicroDSM drive J1 Cables, Centurion DSM drive J1 Cables and Flying Lead Cables.

Figure C1-1: Connection Selector Sheet for MMC Analog Control

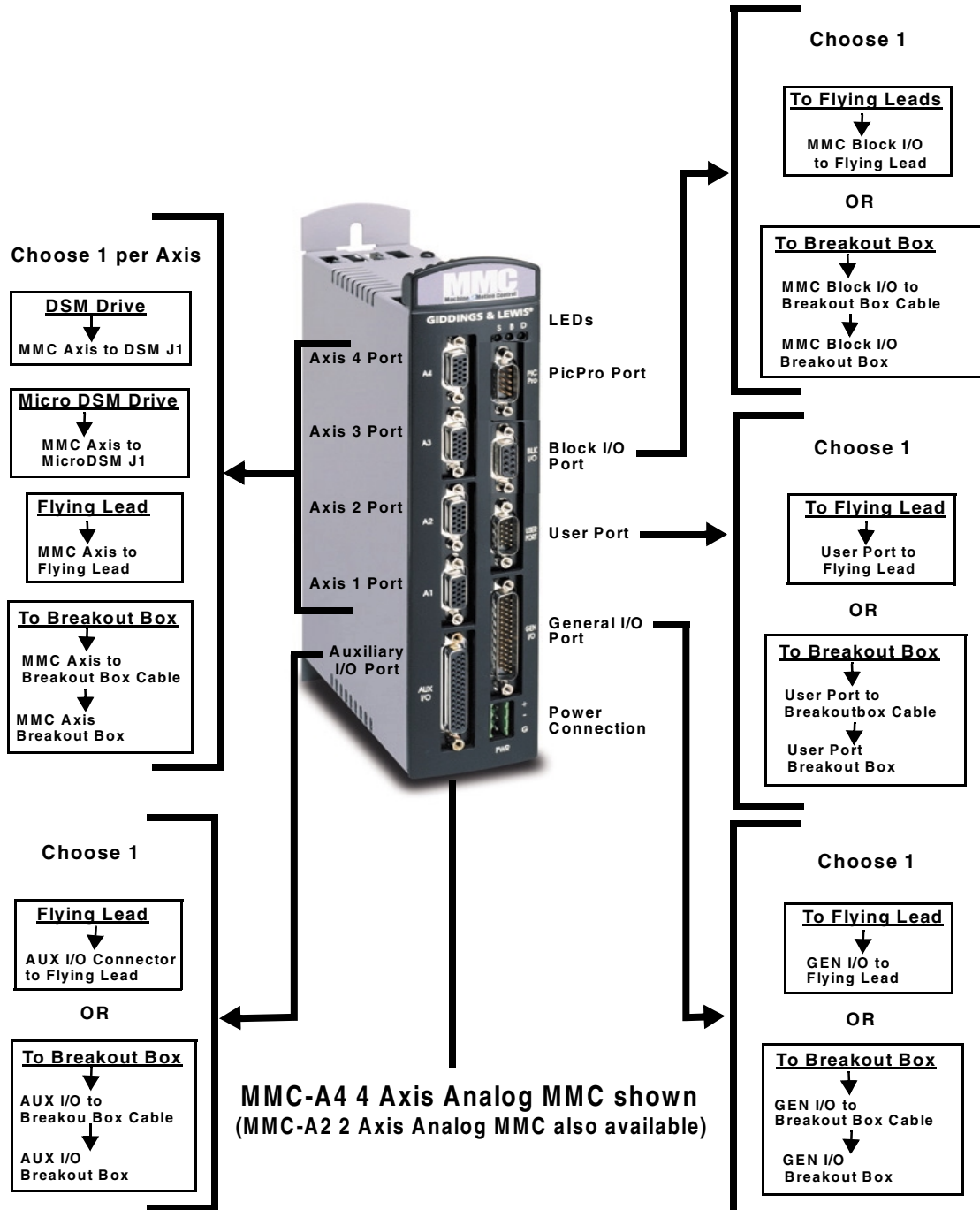
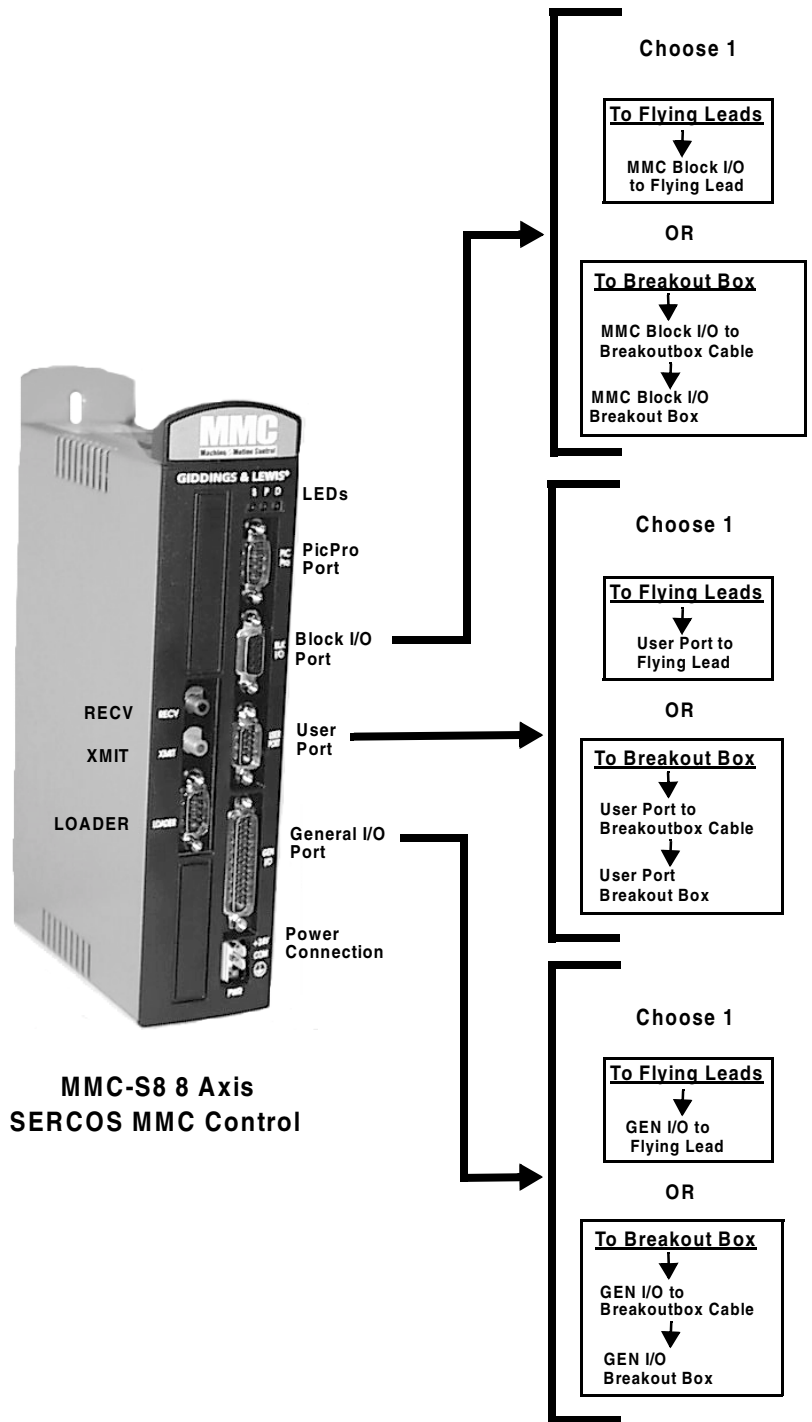

Figure C1-2: Connection Selector Sheet for MMC SERCOS Control



1 Breakout Boxes and Cables

There are five basic and one encoder isolator type MMC Breakout Boxes available that simplify wire termination to the MMC Controls. They include the Axis Connector Breakout Box, Auxiliary I/O Connector Breakout Box, Auxiliary I/O Connector Breakout Box with Encoder Isolators, the User Port Connector Breakout Box, the General I/O Connector Breakout Box and the Block I/O Connector Breakout Box.

A screwdriver with a 0.4 x 2.5 mm blade tip must be used to make connections. When tightening screws, torque to 0.22 to 0.25 Nm. The recommended wire gauge is 30 - 16 AWG UL.

1.1 Breakout Box and Cables for Axis Connector

Table C1-1: Part No. - Breakout Box and Cables to MMC Axis Connector

| (only for MMC Servo Control Axis Ports A1, A2, A3, A4) | | |
|---------------------------------------------------------------|---------------|-------------------------------------|
| Description | Length | Part Number |
| MMC Connector Breakout Box | N/A | M.1016.2529 (old # 401-57277-00) |
| MMC Axis A"n" to Breakout Box Cable | 1' | M.1016.2535 (old # 401-57282-10) |
| MMC Axis A"n" to Breakout Box Cable | 2' | M.1016.2536 (old # 401-57282-20) |
| MMC Axis A"n" to Breakout Box Cable | 3' | M.1016.2537 (old # 401-57282-30) |

1.1.1 Breakout Box for Axis Connector

The Breakout Box for the Axis Connector can be attached to A1, A2 A3 and A4 (one per axis) of the on the MMC. The pinouts on the terminal strip interface provide a one-to-one transfer of the signals from the connector to the respective pin(s) on the terminal block. The ground pin on the terminal strip provides a connection to the metal D-shell.

Figure C1-3: Breakout Box - MMC Axis Connector

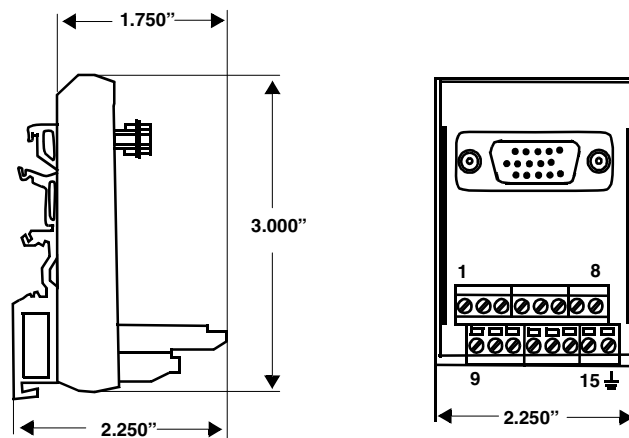



Table C1-2: Pinout - Breakout Box for MMC Axis Connector

| Pin | Description | Pin | Description |
|-----|-------------|---------------------------------------------------------------------------------------|-------------|
| 1 | A | 9 | DA- |
| 2 | A/ | 10 | I/ |
| 3 | B | 11 | +24 VDC out |
| 4 | B/ | 12 | COM |
| 5 | I | 13 | DCOUT1 |
| 6 | DCIN+ | 14 | DCOUT2 |
| 7 | DCIN- | 15 | DCOSS |
| 8 | DA+ |  | Shell |

1.1.2 Cable - Breakout Box to MMC Axis Connector

Figure C1-4: Cable for Axis Connector to Breakout Box

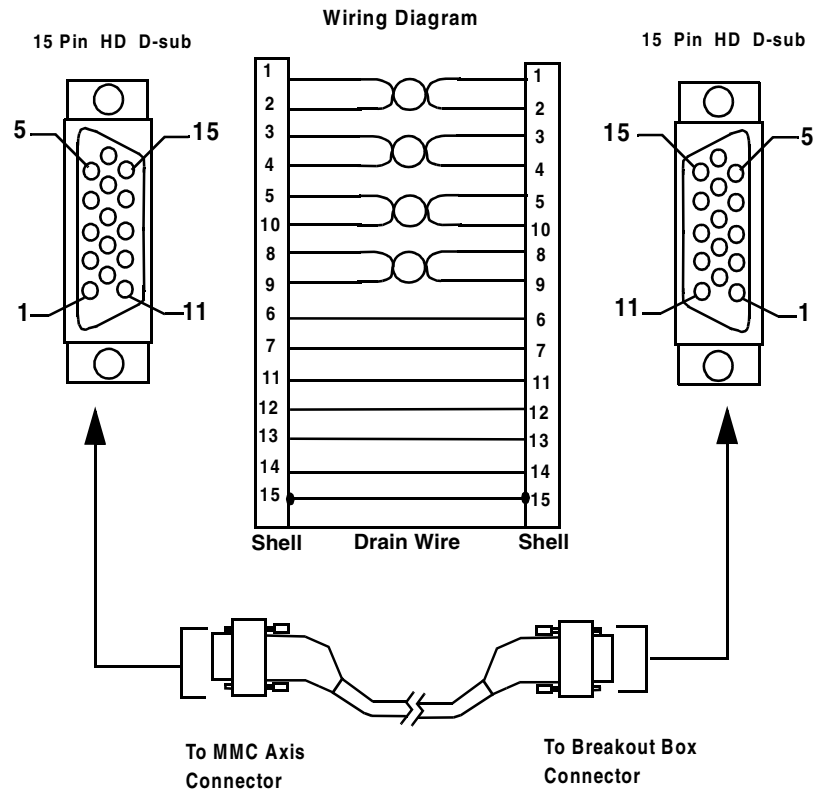

Table C1-3: Pinout - Cable for Axis Connector to Breakout Box

| Pin | Description | Pin | Description |
|-----|-------------|-------|----------------|
| 1 | A | 9 | DA- |
| 2 | A/ | 10 | I/ |
| 3 | B | 11 | +24 VDC out |
| 4 | B/ | 12 | COM |
| 5 | I | 13 | DCOUT1 |
| 6 | DCIN+ | 14 | DCOUT2 |
| 7 | DCIN- | 15 | DCOSS |
| 8 | DA+ | Shell | Drain (Shield) |

1.2 Breakout Box and Cables for Auxiliary I/O Connector

Table C1-4: Part No. - Breakout Box and Cables to MMC AUX I/O Connector

| Description | Length | Part Number |
|---------------------------------------------------|--------|-------------------------------------|
| MMC Aux I/O Breakout Box | N/A | M.1016.2531 (old # 401-57279-00) |
| MMC Connector Breakout Box with Encoder Isolation | N/A | M.1016.4236 (old # 401-26842-00) |
| MMC Gen/Aux I/O Connector to Breakout Box Cable | 1' | M.1016.2539 (old # 401-57283-10) |
| MMC Gen/Aux I/O Connector to Breakout Box Cable | 2' | M.1016.2540 (old # 01-57283-10) |
| MMC Gen/Aux I/O Connector to Breakout Box Cable | 3' | M.1016.2541 (old # 01-57283-10) |

1.2.1 Breakout Box for AUX I/O Connector

On the analog MMC, the Aux I/O connector contains the fast inputs for each axis (including the half axis encoder input) for registration and hardware interrupt capability. It also contains the differential encoder input for the half axis, one analog input, and three 24VDC discrete inputs for each closed loop axis. Typically these inputs would be used for plus and minus end of travel limits and for the reference switch. However, they can be used as general purpose inputs if they are not being used for end-of-travel and reference switch.

The Auxiliary Connector Breakout Box is attached to the AUX I/O connector on the MMC Control. The connector pins marked with the "ground" symbol on the screw connector are connected to the "D" connector shell for shield grounding purposes. The pinouts on the terminal strip interface provide a one-to-one transfer of the signals from the connector to the respective pin(s) on the terminal block.

Figure C1-5: Breakout Box - Auxiliary I/O Connector

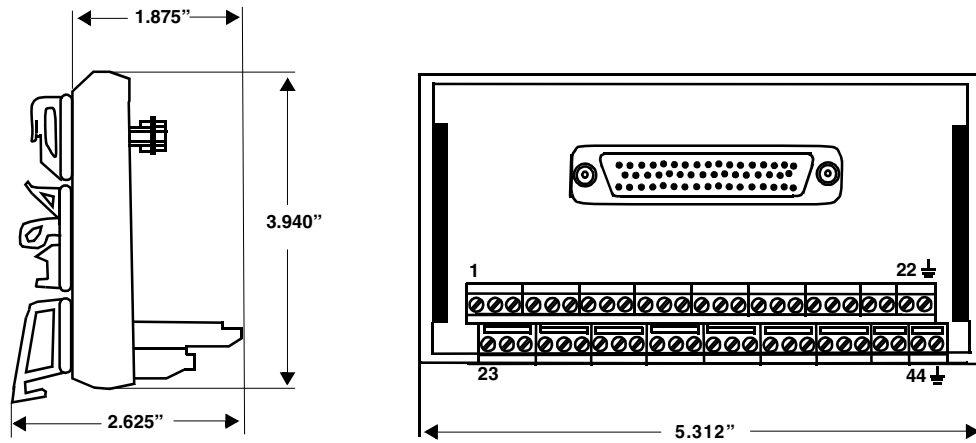

Table C1-5: Pinout - Breakout Box for Auxiliary I/O Connector MMC-A4 (4 axis)



| Pin | Description | Pin | Description | Pin | Description |
|-----|-------------|-----|-------------|---------------------------------------------------------------------------------------------------------|---------------------------------------------------------------------------------------------------------|
| 1 | A | 16 | FASTIN1+ | 31 | DCSSA |
| 2 | A/ | 17 | FASTIN1- | 32 | DCIN1 |
| 3 | B | 18 | SHIELD | 33 | DCIN2 |
| 4 | B/ | 19 | FASTIN2+ | 34 | DCIN3 |
| 5 | I | 20 | FASTIN2- | 35 | DCIN4 |
| 6 | I/ | 21 | SHIELD | 36 | DCIN5 |
| 7 | SHIELD | 22 | FASTIN3+ | 37 | DCIN6 |
| 8 | +24 VDC out | 23 | FASTIN3- | 38 | DCSSB |
| 9 | +24 VDC out | 24 | SHIELD | 39 | DCIN7 |
| 10 | COM | 25 | FASTIN4+ | 40 | DCIN8 |
| 11 | COM | 26 | FASTIN4- | 41 | DCIN9 |
| 12 | +5 VDC out | 27 | SHIELD | 42 | DCIN10 |
| 13 | ANLGIN+ | 28 | FASTIN5+ | 43 | DCIN11 |
| 14 | ANLGIN- | 29 | FASTIN5- | 44 | DCIN12 |
| 15 | SHIELD | 30 | SHIELD |  Shell (Shield) | |
| | | | | |  Shell (Shield) |

Table C1-6: Pinout - Breakout Box for Auxiliary I/O Connector MMC-A2 (2 axis)

| Pin | Description | Pin | Description | Pin | Description |
|-----|-------------|-----|-------------|------------------------------------------------------------------------------------------------------|-------------|
| 1 | A | 16 | FASTIN1+ | 31 | DCSSA |
| 2 | A/ | 17 | FASTIN1- | 32 | DCIN1 |
| 3 | B | 18 | SHIELD | 33 | DCIN2 |
| 4 | B/ | 19 | FASTIN2+ | 34 | DCIN3 |
| 5 | I | 20 | FASTIN2- | 35 | DCIN4 |
| 6 | I/ | 21 | SHIELD | 36 | DCIN5 |
| 7 | SHIELD | 22 | NC | 37 | DCIN6 |
| 8 | +24 VDC out | 23 | NC | 38 | NC |
| 9 | +24 VDC out | 24 | SHIELD | 39 | NC |
| 10 | COM | 25 | NC | 40 | NC |
| 11 | COM | 26 | NC | 41 | NC |
| 12 | +5 VDC out | 27 | SHIELD | 42 | NC |
| 13 | ANLGIN+ | 28 | FASTIN5+ | 43 | NC |
| 14 | ANLGIN- | 29 | FASTIN5- | 44 | NC |
| 15 | SHIELD | 30 | SHIELD |  Shell (Shield) | |
| | | | | | |

1.2.2 Auxiliary I/O Connector Breakout Box with Encoder Isolators

A second type of auxiliary I/O breakout box has encoder isolator circuits incorporated into the module. These circuits boost the encoder common mode voltages allowed from approximately 10 volts to hundreds of volts. This allows reliable encoder operation in the presence of large amounts of electrical noise and ground disturbances relative to the MMC unit.

The Breakout Box for the Auxiliary I/O Connector with Encoder Isolators is attached to the AUX I/O connector on the MMC Control. The connector pins marked with the "ground" symbol on the screw connector are connected to the "D" connector shell for shield grounding purposes.

The pinouts on the screw terminal strip are identical to those of the breakout boxes for the Auxiliary I/O Connector except that 5V is not brought out on screw terminal 12 and the encoder inputs are optically isolated.

Figure C1-6: Breakout Box - Auxiliary I/O Connector with Encoder Isolators

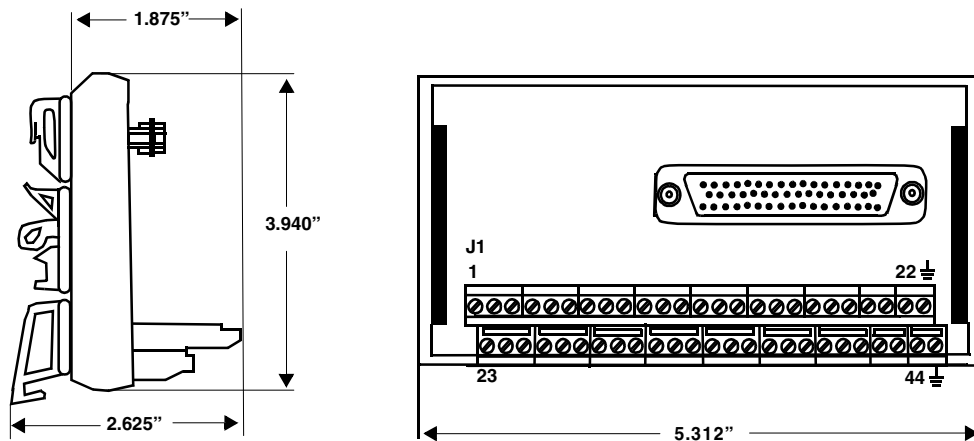

1.2.2.1 Encoder Isolator Connections

Figure C1-7: Connections from Encoder to Encoder Isolated AUX I/O

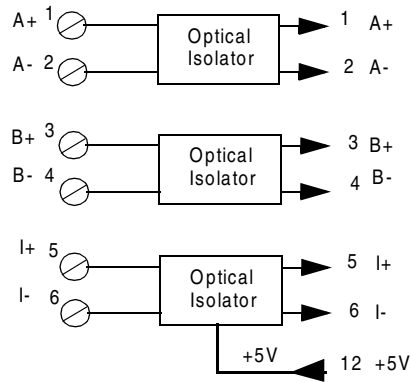

Note: Pin 12, the +5V ($\pm 20\%$), is not carried thru to the screw terminal. (The pin is insufficient to provide power to an encoder; an external 5V supply is required for an encoder.)

Figure C1-8: Encoder and Power Connections for Encoder Isolator

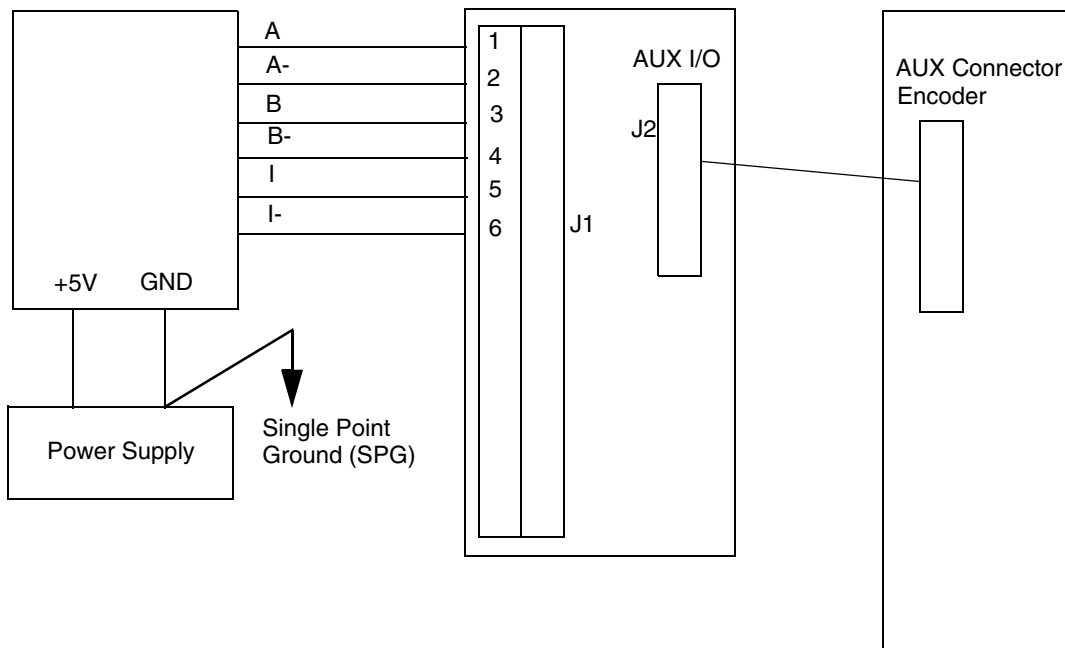

1.2.2.2 Input Requirements for Encoder Isolator Breakout Box

Although the isolator interface can be used single ended or differential, a RS-422 differential type driver is recommended.

Table C1-7: Encoder Isolator Breakout Box Input Requirements

| Input Item | Specification |
|---------------------------------------------------------------------------|-----------------------------------------------------|
| Input current/voltage (minimum) | 2.5ma @ 2.5 volts |
| Input current/voltage (maximum) | 22ma @ 7.0 volts |
| Input pulse width (minimum) | 600 nanoseconds |
| Input frequency (maximum) on A or B inputs from Quadrature output encoder | 250KHz (1.0 MHz count rate, using quadrature edges) |
| Input frequency (maximum) on A or B inputs from Pulse output encoder | 500KHz (500KHz count rate) |

1.2.3 Cable - Breakout Box to AUX I/O Connector

Figure C1-9: Cable for AUX I/O Connector to Breakout Box

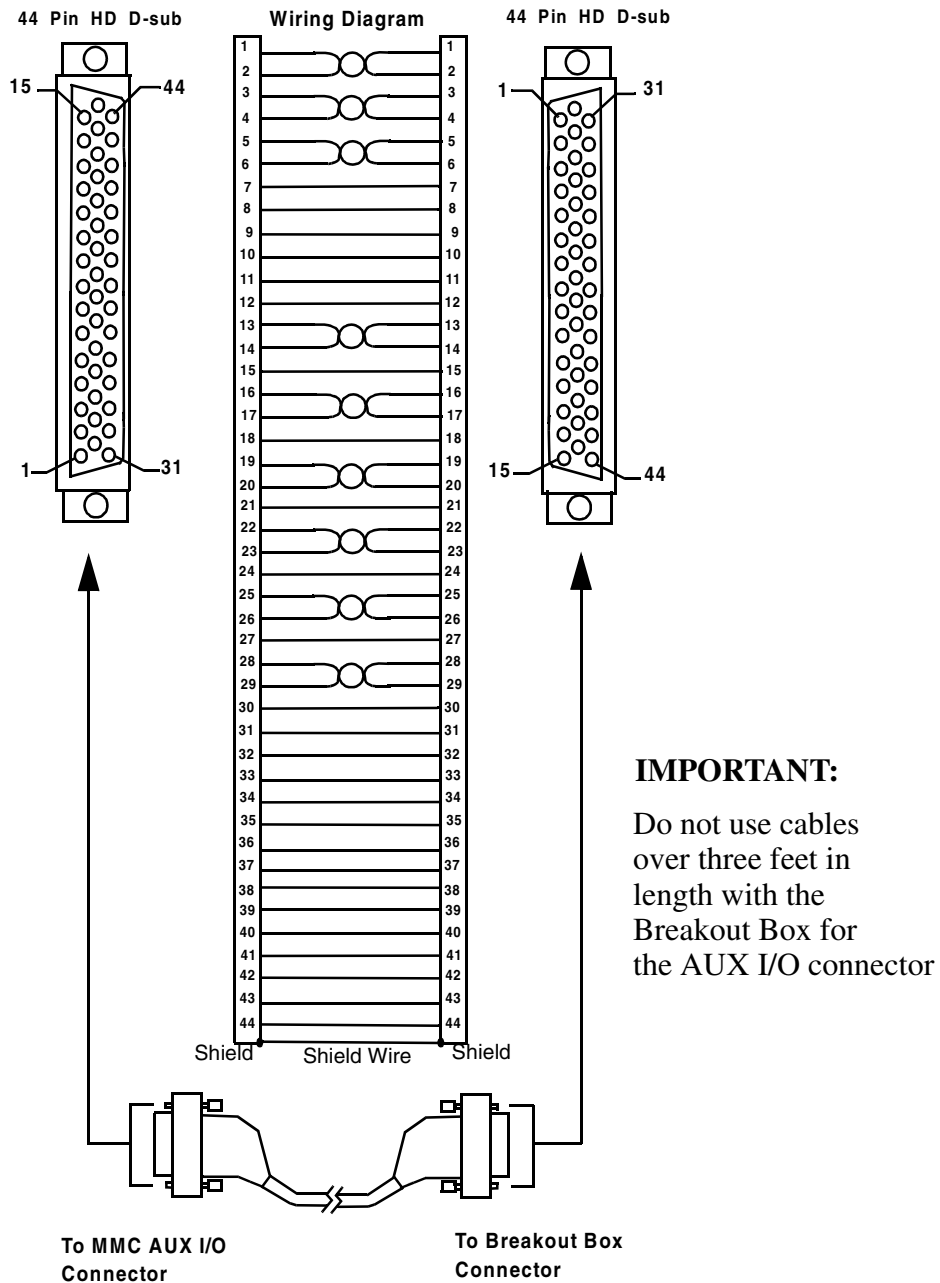

The MMC Gen I/O connector cable at the MMC (female connection) is compatible with the MMC Aux I/O breakout box connector cable. Similarly, the MMC Aux I/O connector cable at the MMC (male connection) is compatible with the MMC Gen I/O breakout box connector cable. With this compatibility, the cables between the MMC Aux/Gen connectors and the Aux/Gen breakout boxes are the same. To move a cable from one to the other, just swap the cable ends.

Table C1-8: : Pinout - Cable for AUX I/O Connector to Breakout Box (MMC-A4)





| Pin | Description | Pin | Description | Pin | Description |
|-----|-------------|-----|-------------|---------------------------------------------------------------------------------------|----------------|
| 1 | A | 16 | FASTIN1+ | 31 | DCSSA |
| 2 | A/ | 17 | FASTIN1- | 32 | DCIN1 |
| 3 | B | 18 | SHIELD | 33 | DCIN2 |
| 4 | B/ | 19 | FASTIN2+ | 34 | DCIN3 |
| 5 | I | 20 | FASTIN2- | 35 | DCIN4 |
| 6 | I/ | 21 | SHIELD | 36 | DCIN5 |
| 7 | SHIELD | 22 | FASTIN3+ | 37 | DCIN6 |
| 8 | +24 VDC out | 23 | FASTIN3- | 38 | DCSSB |
| 9 | +24 VDC out | 24 | SHIELD | 39 | DCIN7 |
| 10 | COM | 25 | FASTIN4+ | 40 | DCIN8 |
| 11 | COM | 26 | FASTIN4- | 41 | DCIN9 |
| 12 | +5 VDC out | 27 | SHIELD | 42 | DCIN10 |
| 13 | ANLGIN+ | 28 | FASTIN5+ | 43 | DCIN11 |
| 14 | ANLGIN- | 29 | FASTIN5- | 44 | DCIN12 |
| 15 | SHIELD | 30 | SHIELD |  | Shell (Shield) |
| | | | |  | Shell (Shield) |

Table C1-9: : Pinout - Cable for AUX I/O Connector to Breakout Box (MMC-A2)

| Pin | Description | Pin | Description | Pin | Description |
|-----|-------------|-----|-------------|---------------------------------------------------------------------------------------|----------------|
| 1 | A | 16 | FASTIN1+ | 31 | DCSSA |
| 2 | A/ | 17 | FASTIN1- | 32 | DCIN1 |
| 3 | B | 18 | SHIELD | 33 | DCIN2 |
| 4 | B/ | 19 | FASTIN2+ | 34 | DCIN3 |
| 5 | I | 20 | FASTIN2- | 35 | DCIN4 |
| 6 | I/ | 21 | SHIELD | 36 | DCIN5 |
| 7 | SHIELD | 22 | NC | 37 | DCIN6 |
| 8 | +24 VDC out | 23 | NC | 38 | NC |
| 9 | +24 VDC out | 24 | SHIELD | 39 | NC |
| 10 | COM | 25 | NC | 40 | NC |
| 11 | COM | 26 | NC | 41 | NC |
| 12 | +5 VDC out | 27 | SHIELD | 42 | NC |
| 13 | ANLGIN+ | 28 | FASTIN5+ | 43 | NC |
| 14 | ANLGIN- | 29 | FASTIN5- | 44 | NC |
| 15 | SHIELD | 30 | SHIELD |  | Shell (Shield) |
| | | | |  | Shell (Shield) |

1.3 Breakout Box and Cables for Block I/O Connector

1.3.1 Block I/O Connector Breakout Box

The Block I/O connector is used for communicating with distributed block I/O modules. Up to 77 blocks can be connected to a single MMC. A complete family of block I/O modules are available, including AC and DC discrete I/O, analog I/O, stepper and resolver.

The Block I/O Connector Breakout Box is attached to the BLK I/O connector on the MMC Control. The pinouts on the terminal strip interface provide a one-to-one transfer of the signals from the connector to the respective pin(s) on the terminal block.

Table C1-10: Part No. - Breakout Box and Cables to MMC BLK I/O Connector

| Description | Length | Part Number |
|-----------------------------------------------|---------------|-------------------------------------|
| MMC Block I/O Breakout Box | N/A | M.1016.2533 (old # 401-57281-00) |
| MMC Block I/O Connector to Breakout Box Cable | 1' | M.1016.2543 (old # 401-57284-10) |
| MMC Block I/O Connector to Breakout Box Cable | 2' | M.1016.2544 (old # 01-57284-20) |
| MMC Block I/O Connector to Breakout Box Cable | 3' | M.1016.25415 (old # 01-57284-30) |

Figure C1-10: Breakout Box - BLK I/O Connector

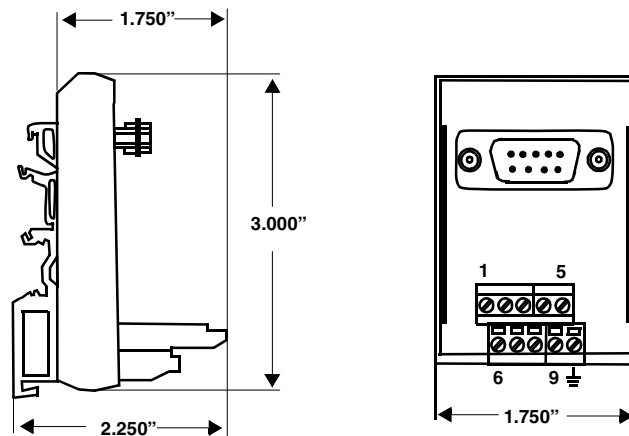

Table C1-11: Pinout - Breakout Box for Block I/O Connector

| Pin | Desc. | In/Out | Pin | Desc. | In/Out | Pin | Desc. | Pin |
|-----------------------------------------------------------------------------------------------------------------------------------------------------------------------------------------|---------------------------|--------|-----|---------------------------|--------|-----|-------------------------|-----|
| 1 | NC | | 4 | Block I/O Transmit Data - | Out | 7 | Shield (see Note below) | |
| 2 | NC | | 5 | Block I/O Receive Data + | In | 8 | NC | |
| 3 | Block I/O Transmit Data + | Out | 6 | Block I/O Receive Data - | In | 9 | NC | |
| | | | | | | ⏏ | Shell (Shield) | |
| <p>NOTE: Pin 7 of the Block I/O connector is connected to the connector shell within the MMC. Therefore, the shield may be connected to either pin 7 or the connector shell.</p> | | | | | | | | |

1.3.2 Cable - Breakout Box to Block I/O Connector

Figure C1-11: Cable for Block I/O Connector to Breakout Box

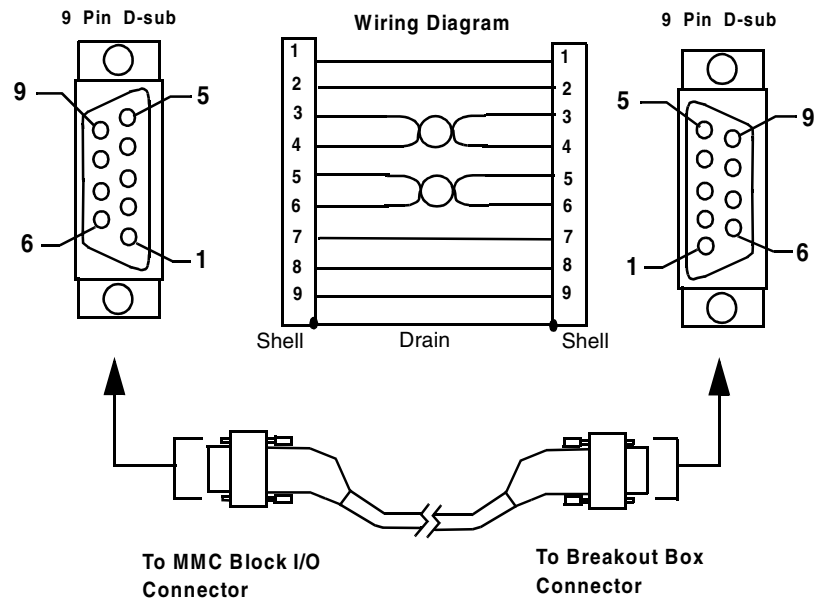

Table C1-12: Pinout - Cable for BLK I/O Connector to Breakout Box

| Pin | Description | In/Out |
|-----|---------------------------|--------|
| 1 | NC | |
| 2 | NC | |
| 3 | Block I/O Transmit Data + | Out |
| 4 | Block I/O Transmit Data - | Out |
| 5 | Block I/O Receive Data + | In |
| 6 | Block I/O Receive Data - | In |
| 7 | Shield | |
| 8 | NC | |
| 9 | NC | |

1.4 Breakout Box and Cables for User Port Connector

1.4.1 User Port Connector Breakout Box

The User Port connector on the MMC control is a serial port typically used for operator interface. The User Port Connector Breakout Box is attached to the USER PORT connector on the MMC control. The pinouts on the terminal strip interface provide a one-to-one transfer of the signals from the connector to the respective pin(s) on the terminal block.

Table C1-13: Part No. - Breakout Box and Cables to MMC USER PORT

| Description | Length | Part Number |
|-------------------------------------|---------------|-------------------------------------|
| MMC User Port Breakout Box | N/A | M.1016.2530 (old # 401-57278-00) |
| MMC User Port to Breakout Box Cable | 1' | M.1016.2715 (old # 401-57412-10) |
| MMC User Port to Breakout Box Cable | 2' | M.1016.2716 (old # 401-57412-20) |
| MMC User Port to Breakout Box Cable | 3' | M.1016.2717 (old # 401-57412-30) |

Figure C1-12: User Port Connector Breakout Box

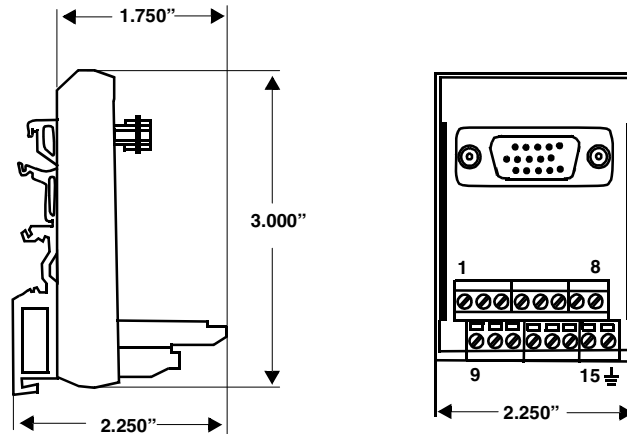

Table C1-14: : Pinout - Breakout Box for USER PORT

| Pin | Description | In/Out | Pin | Description | In/.Out |
|-----|---------------------------|--------|-----|-----------------------|---------|
| 1 | NC | | 9 | RS232 Receive Data | In |
| 2 | NC | | 10 | RS232 Transmit Data | Out |
| 3 | +5V (50mA Max) | Out | 11 | NC | |
| 4 | RS232 Data Terminal Ready | Out | 12 | RS485 Receive Data + | In |
| 5 | RS232 Request to Send | Out | 13 | RS485 Receive Data - | In |
| 6 | NC | | 14 | RS485 Transmit Data + | Out |
| 7 | RS232 Clear to Send | In | 15 | RS485 Transmit Data - | Out |
| 8 | Signal Ground | In/Out | ⏏ | Shell (Shield) | |

1.4.2 Cable - Breakout Box to USER PORT Connector

Figure C1-13: Cable for User Port Connector to Breakout Box

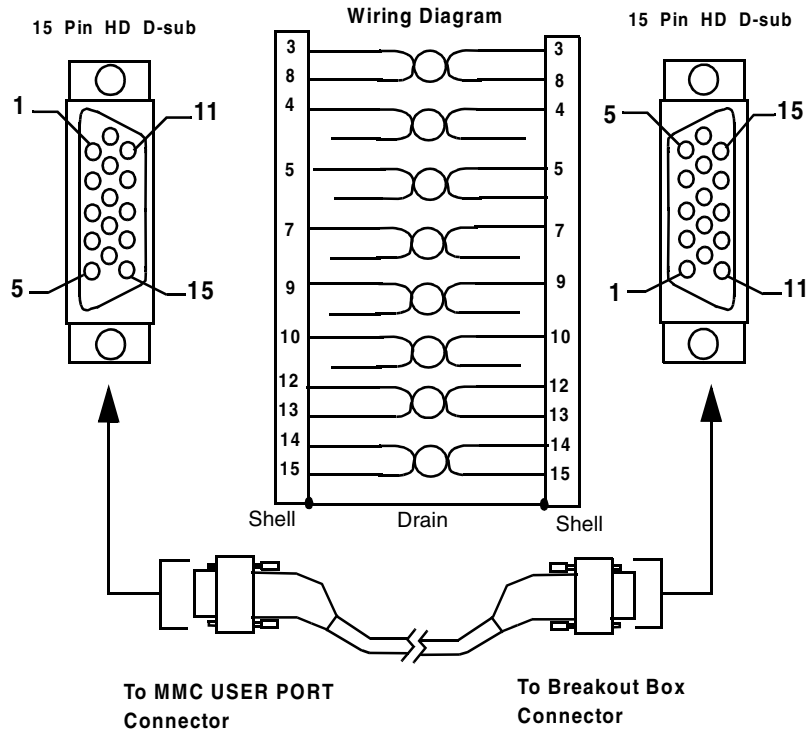

Table C1-15: Pinout - Cable for USER PORT Connector to Breakout Box

| Pin | Description | In/Out | Pin | Description | In/.Out |
|-----|---------------------------|--------|-------|-----------------------|---------|
| 1 | NC | | 9 | RS232 Receive Data | In |
| 2 | NC | | 10 | RS232 Transmit Data | Out |
| 3 | +5V (50mA Max) | Out | 11 | NC | |
| 4 | RS232 Data Terminal Ready | Out | 12 | RS485 Receive Data + | In |
| 5 | RS232 Request to Send | Out | 13 | RS485 Receive Data - | In |
| 6 | NC | | 14 | RS485 Transmit Data + | Out |
| 7 | RS232 Clear to Send | In | 15 | RS485 Transmit Data - | Out |
| 8 | Signal Ground | In/Out | Shell | Drain (shield) | |

1.5 Breakout Box and Cables for General I/O Connector

Table C1-16: : Part No. - Breakout Box and Cables to MMC GEN I/O Connector

| Description | Length | Part Number |
|-------------------------------------------------|--------|-------------------------------------|
| MMC Gen I/O Breakout Box | N/A | M.1016.2532 (old # 401-57280-00) |
| MMC Gen/Aux I/O Connector to Breakout Box Cable | 1' | M.1016.2539 (old # 401-57283-10) |
| MMC Gen/Aux I/O Connector to Breakout Box Cable | 2' | M.1016.2540 (old # 401-57283-10) |
| MMC Gen/Aux I/O Connector to Breakout Box Cable | 3' | M.1016.2541 (old # 401-57283-10) |

1.5.1 Breakout Box for GEN I/O Connector

The Gen I/O connector contains sixteen general-purpose 24 VDC discrete inputs (sink or source) and sixteen general-purpose 24 VDC discrete outputs (source only). Any of the 16 outputs can be used as CAM or PLS outputs. Two of the inputs (number 1 and number 9) have hardware interrupt capability and can be used to trigger hardware interrupt tasks in the application program.

The General I/O Connector Breakout Box is connected to the GEN I/O connector on the MMC Control. The pinouts on the terminal strip interface provide a one-to-one transfer of the signals from the connector to the respective pin(s) on the terminal block.

Figure C1-14: General I/O Connector Breakout Box

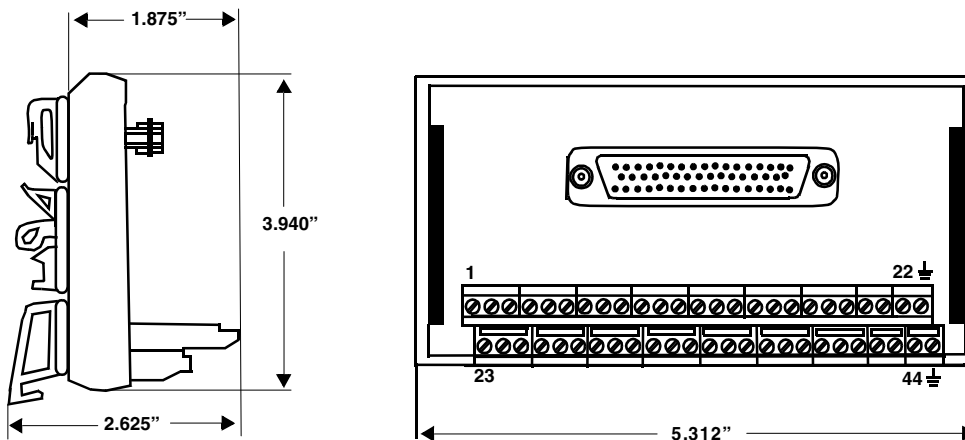

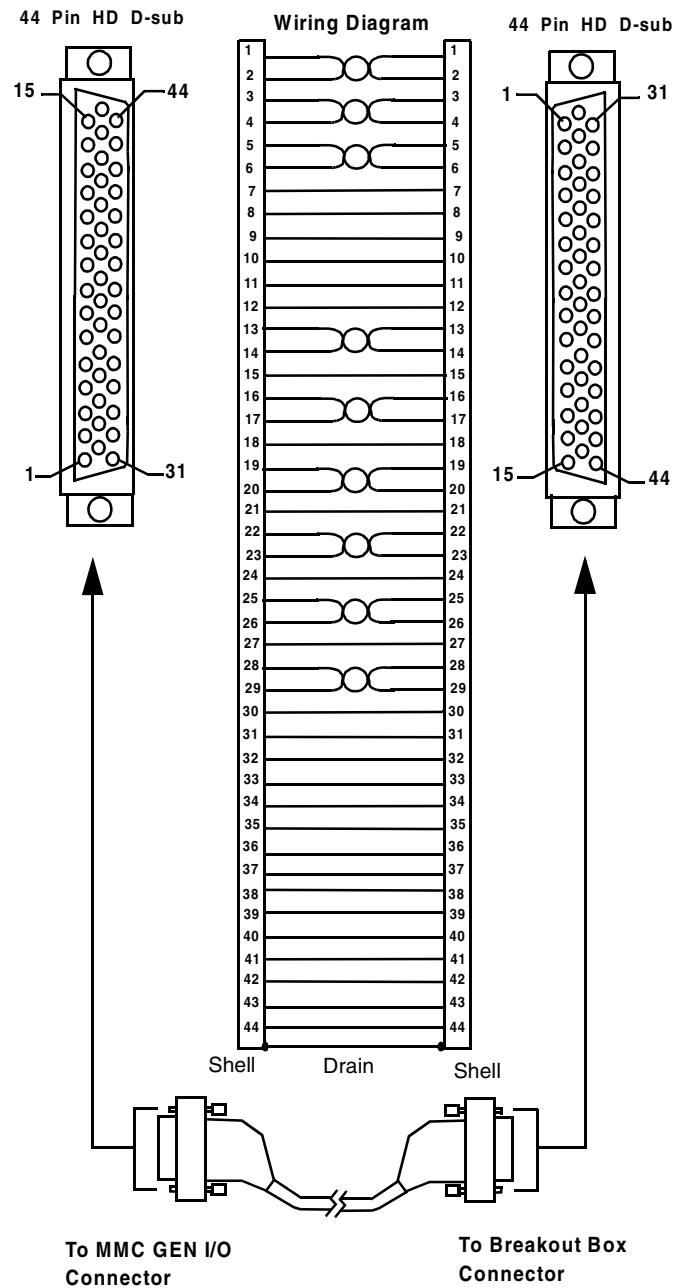

Table C1-17: : Pinout - Breakout Box for GEN I/O Connector

| Pin | Description | In/Out | Pin | Description | In/Out | Pin | Description | In/Out |
|-----|-------------|--------|-----|-------------|--------|---------------------------------------------------------------------------------------|----------------|--------|
| 1 | DCOUT1 | Out | 16 | DCOUT16 | Out | 31 | NC | |
| 2 | DCOUT2 | Out | 17 | NC | | 32 | NC | |
| 3 | DCOUT3 | Out | 18 | NC | | 33 | NC | |
| 4 | DCOUT4 | Out | 19 | NC | | 34 | IO24V | Out |
| 5 | DCOUT5 | Out | 20 | IO24V | Out | 35 | DCSS2 | In |
| 6 | DCOUT6 | Out | 21 | DCSS1 | In | 36 | IO24C | Out |
| 7 | DCOUT7 | Out | 22 | IO24C | Out | 37 | DCIN9 | In |
| 8 | DCOUT8 | Out | 23 | DCIN1 | In | 38 | DCIN10 | In |
| 9 | DCOUT9 | Out | 24 | DCIN2 | In | 39 | DCIN11 | In |
| 10 | DCOUT10 | Out | 25 | DCIN3 | In | 40 | DCIN12 | In |
| 11 | DCOUT11 | Out | 26 | DCIN4 | In | 41 | DCIN13 | In |
| 12 | DCOUT12 | Out | 27 | DCIN5 | In | 42 | DCIN14 | In |
| 13 | DCOUT13 | Out | 28 | DCIN6 | In | 43 | DCIN15 | In |
| 14 | DCOUT14 | Out | 29 | DCIN7 | In | 44 | DCIN16 | In |
| 15 | DCOUT15 | Out | 30 | DCIN8 | In |  | Drain (Shield) | |
| | | | | | |  | Drain (Shield) | |

1.5.2 Cable - GEN I/O Connector to Breakout Box

Figure C1-15: Cable for GEN I/O Connector to Breakout Box



The MMC Gen I/O connector cable at the MMC (female connection) is compatible with the MMC Aux I/O breakout box connector cable. Similarly, the MMC Aux I/O connector cable at the MMC (male connection) is compatible with the MMC Gen I/O breakout box connector cable. With this compatibility, the cables between the MMC Aux/Gen connectors and the Aux/Gen breakout boxes are the same. To move a cable from one to the other, just swap the cable ends.

C.1 - Breakout Boxes, Centurion Connector Cables and Flying Lead Cables

Table C1-18: Pinout - Cable for GEN I/O Connector to Breakout Box

| Pin | Description | In/Out | Pin | Description | In/Out | Pin | Description | In/Out |
|-----|-------------|--------|-----|-------------|--------|-------|----------------|--------|
| 1 | DCOUT1 | Out | 16 | DCOUT16 | Out | 31 | NC | |
| 2 | DCOUT2 | Out | 17 | NC | | 32 | NC | |
| 3 | DCOUT3 | Out | 18 | NC | | 33 | NC | |
| 4 | DCOUT4 | Out | 19 | NC | | 34 | IO24V | Out |
| 5 | DCOUT5 | Out | 20 | IO24V | Out | 35 | DCSS2 | In |
| 6 | DCOUT6 | Out | 21 | DCSS1 | In | 36 | IO24C | Out |
| 7 | DCOUT7 | Out | 22 | IO24C | Out | 37 | DCIN9 | In |
| 8 | DCOUT8 | Out | 23 | DCIN1 | In | 38 | DCIN10 | In |
| 9 | DCOUT9 | Out | 24 | DCIN2 | In | 39 | DCIN11 | In |
| 10 | DCOUT10 | Out | 25 | DCIN3 | In | 40 | DCIN12 | In |
| 11 | DCOUT11 | Out | 26 | DCIN4 | In | 41 | DCIN13 | In |
| 12 | DCOUT12 | Out | 27 | DCIN5 | In | 42 | DCIN14 | In |
| 13 | DCOUT13 | Out | 28 | DCIN6 | In | 43 | DCIN15 | In |
| 14 | DCOUT14 | Out | 29 | DCIN7 | In | 44 | DCIN16 | In |
| 15 | DCOUT15 | Out | 30 | DCIN8 | In | Shell | Drain (shield) | |

2 Cables from Centurion Drives to MMC Axis Connector

2.1 Cable - DSM J1 Connector to MMC Axis Connector

Table C1-19: Part No. - Cable from DSM J1 Connector to MMC Axis Connector

| (only for MMC Servo Control Axis Ports A1, A2, A3, A4) | | |
|--------------------------------------------------------|--------|-------------------------------------|
| Description | Length | Part Number |
| MMC Axis A'n' to DSM J1 Connector | 1' | M.1016.2516 (old # 401-57269-10) |
| MMC Axis A'n' to DSM J1 Connector | 2' | M.1016.2517 (old # 401-57269-20) |
| MMC Axis A'n' to DSM J1 Connector | 3' | M.1016.2518 (old # 401-57269-30) |

Figure C1-16: Cable from DSM J1 Connector to MMC Axis Connector

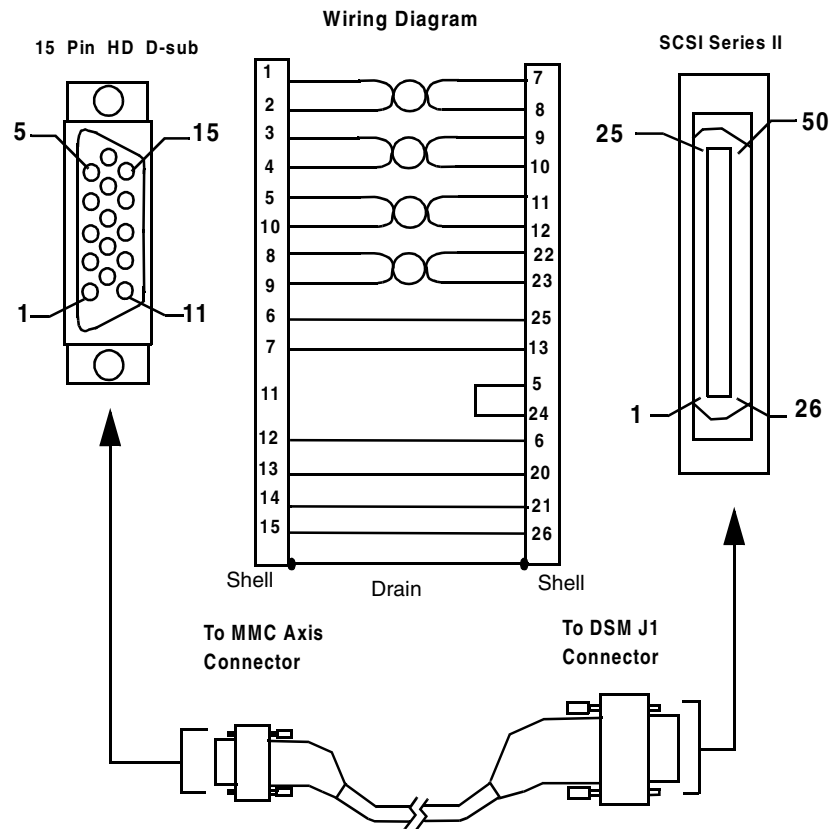

Table C1-20: Pinouts - Cable from DSM J1 Connector to MMC Axis Connecto

| 15-Pin D-sub | | SCSI Series II | | | |
|--------------|----------------|----------------|--------------------|-----|---------------------|
| Pin | Description | Pin | Description | Pin | Description |
| 1 | A | 1 | Encoder +5VDC | 26 | Isolated +24VDC |
| 2 | A/ | 2 | Encoder COM | 27 | + I Limit |
| 3 | B | 3 | Encoder +5VDC | 28 | Analog COM |
| 4 | B/ | 4 | Encoder COM | 29 | - I Limit |
| 5 | I | 5 | Isolated +24VDC | 30 | Analog Output 1 |
| 6 | DCIN+ | 6 | Isolated 24V COM | 31 | Analog Output 2 |
| 7 | DCIN- | 7 | Mtr Output Chnl A+ | 32 | Selectable Input 1 |
| 8 | DA+ | 8 | Mtr Output Chnl A- | 33 | Selectable Input 2 |
| 9 | DA- | 9 | Mtr Output Chnl B+ | 34 | Selectable Input 3 |
| 10 | I/ | 10 | Mtr Output Chnl B- | 35 | Selectable Input 4 |
| 11 | +24 VDC out | 11 | Mtr Output Chnl I+ | 36 | RSVD |
| 12 | COM | 12 | Mtr Output Chnl I- | 37 | RSVD |
| 13 | DCOUT1 | 13 | Isolated 24V COM | 38 | RSVD |
| 14 | DCOUT2 | 14 | Auxiliary Chnl A+ | 39 | RSVD |
| 15 | DCOSS | 15 | Auxiliary Chnl A- | 40 | RSVD |
| Shell | Drain (shield) | 16 | Auxiliary Chnl B+ | 41 | RSVD |
| | | 17 | Auxiliary Chnl B- | 42 | Selectable Output 1 |
| | | 18 | Auxiliary Chnl I+ | 43 | Selectable Output 2 |
| | | 19 | Auxiliary Chnl I- | 44 | Selectable Output 3 |
| | | 20 | Drive Enable | 45 | Selectable Output 4 |
| | | 21 | Fault Reset | 46 | RSVD |
| | | 22 | Analog Cmnd + | 47 | RSVD |
| | | 23 | Analog Cmnd - | 48 | RSVD |
| | | 24 | Drive Ready + | 49 | Brake Enable + |
| | | 25 | Drive Ready - | 50 | Brake Enable - |
| | | | Shell | | Drain (shield) |

2.2 Cable - MicroDSM J1 to MMC Axis Connector

Table C1-21: Part No. - Cable from MicroDSM J1 Connector to MMC Axis Connector

| (only for MMC Servo Control Axis Ports A1, A2, A3, A4) | | |
|---------------------------------------------------------------|---------------|-------------------------------------|
| Description | Length | Part Number |
| MMC Axis A"n" to MicroDSM J1 Connector | 1' | M.1016.2512 (old # 401-57268-10) |
| MMC Axis A"n" to MicroDSM J1 Connector | 2' | M.1016.2513 (old # 401-57268-20) |
| MMC Axis A"n" to MicroDSM J1 Connector | 3' | M.1016.2514 (old # 401-57268-30) |

Figure C1-17: Cable from MicroDSM J1 Connector to MMC Axis Connector

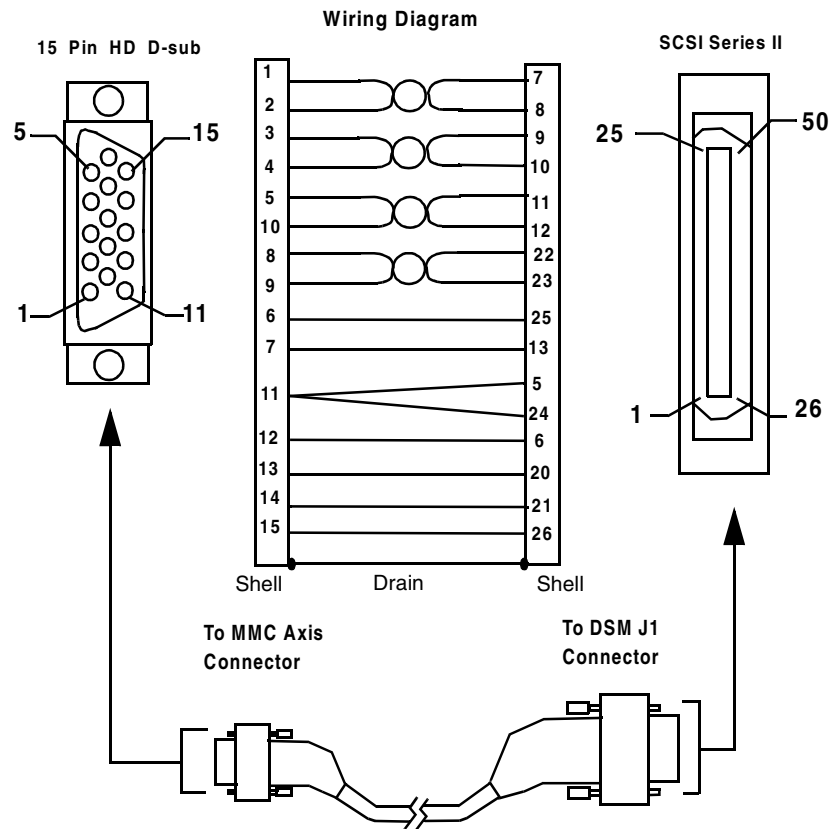

Table C1-22: Pinouts - Cable from MicroDSM J1 Connector to MMC Axis Connector

| 15-Pin D-sub | | SCSI Series II | | | |
|--------------|----------------|----------------|--------------------|-----|---------------------|
| Pin | Description | Pin | Description | Pin | Description |
| 1 | A | 1 | Encoder +5VDC | 26 | External I/O Power |
| 2 | A/ | 2 | Encoder 5V COM | 27 | I Limit |
| 3 | B | 3 | Encoder +5VDC | 28 | Analog COM |
| 4 | B/ | 4 | Encoder 5V COM | 29 | Reserved |
| 5 | I | 5 | External I/O Power | 30 | Reserved |
| 6 | DCIN+ | 6 | External I/O Com | 31 | Analog Output 1 |
| 7 | DCIN- | 7 | Mtr Output Chnl A+ | 32 | Selectable Input 1 |
| 8 | DA+ | 8 | Mtr Output Chnl A- | 33 | Selectable Input 2 |
| 9 | DA- | 9 | Mtr Output Chnl B+ | 34 | Selectable Input 3 |
| 10 | I/ | 10 | Mtr Output Chnl B- | 35 | Reserved |
| 11 | +24 VDC out | 11 | Mtr Output Chnl I+ | 36 | Reserved |
| 12 | COM | 12 | Mtr Output Chnl I- | 37 | Reserved |
| 13 | DCOUT1 | 13 | Exteranal I/O COM | 38 | Reserved |
| 14 | DCOUT2 | 14 | Auxiliary Chnl A+ | 39 | Reserved |
| 15 | DCOSS | 15 | Auxiliary Chnl A- | 40 | Reserved |
| Shell | Drain (shield) | 16 | Auxiliary Chnl B+ | 41 | Reserved |
| | | 17 | Auxiliary Chnl B- | 42 | Selectable Output 1 |
| | | 18 | Auxiliary Chnl I+ | 43 | Selectable Output 2 |
| | | 19 | Auxiliary Chnl I- | 44 | Reserved |
| | | 20 | Drive Enable | 45 | Reserved |
| | | 21 | Fault Reset | 46 | Reserved |
| | | 22 | Analog Cmnd + | 47 | Reserved |
| | | 23 | Analog Cmnd - | 48 | Reserved |
| | | 24 | Drive Ready + | 49 | Brake Enable + |
| | | 25 | Drive Ready - | 50 | Brake Enable - |
| | | Shell | Drain (shield) | | |

3 Flying Lead Cables to MMC Control

3.1 Flying Lead Cable to MMC Axis Connector

Table C1-23: Part No. - Flying Lead Cable to MMC Axis Connector

| (for MMC Servo Control Axis Ports A1, A2, A3, A4) | | |
|---------------------------------------------------|--------|-------------------------------------|
| Description | Length | Part Number |
| MMC Axis A"n" to Flying Lead Cable | 10' | M.1016.2519 (old # 401-57270-00) |

Figure C1-18: Flying Lead Cable to MMC Axis Connector

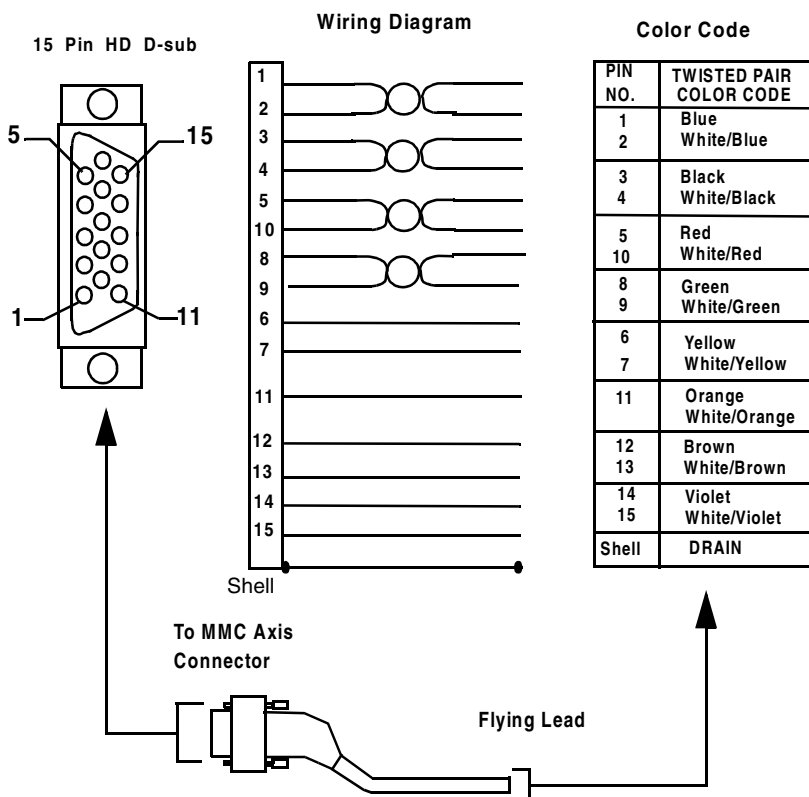

Table C1-24: Pinout - Flying Lead Cable to MMC Axis Connector

| Pin | Description | Pin | Description | Pin | Description | Pin | Description |
|-----|-------------|-----|-------------|-----|-------------|-------|----------------|
| 1 | A | 6 | DCIN+ | 11 | +24 VDC | Shell | Drain (shield) |
| 2 | A/ | 7 | DCIN- | 12 | COM | | |
| 3 | B | 8 | DA+ | 13 | DCOUT1 | | |
| 4 | B/ | 9 | DA- | 14 | DCOUT2 | | |
| 5 | I | 10 | I/ | 15 | DCOSS | | |

3.2 Flying Lead Cable to MMC AUX I/O Connector

Table C1-25: Part No. - Flying Lead Cable to MMC AUX I/O Connector

| Description | Length | Part Number |
|--------------------------------------------|--------|-------------------------------------|
| MMC AUX I/O Connector to Flying Lead Cable | 10' | M.1016.2566 (old # 401-57311-00) |

Figure C1-19: Flying Lead Cable to MMC AUX I/O Connector

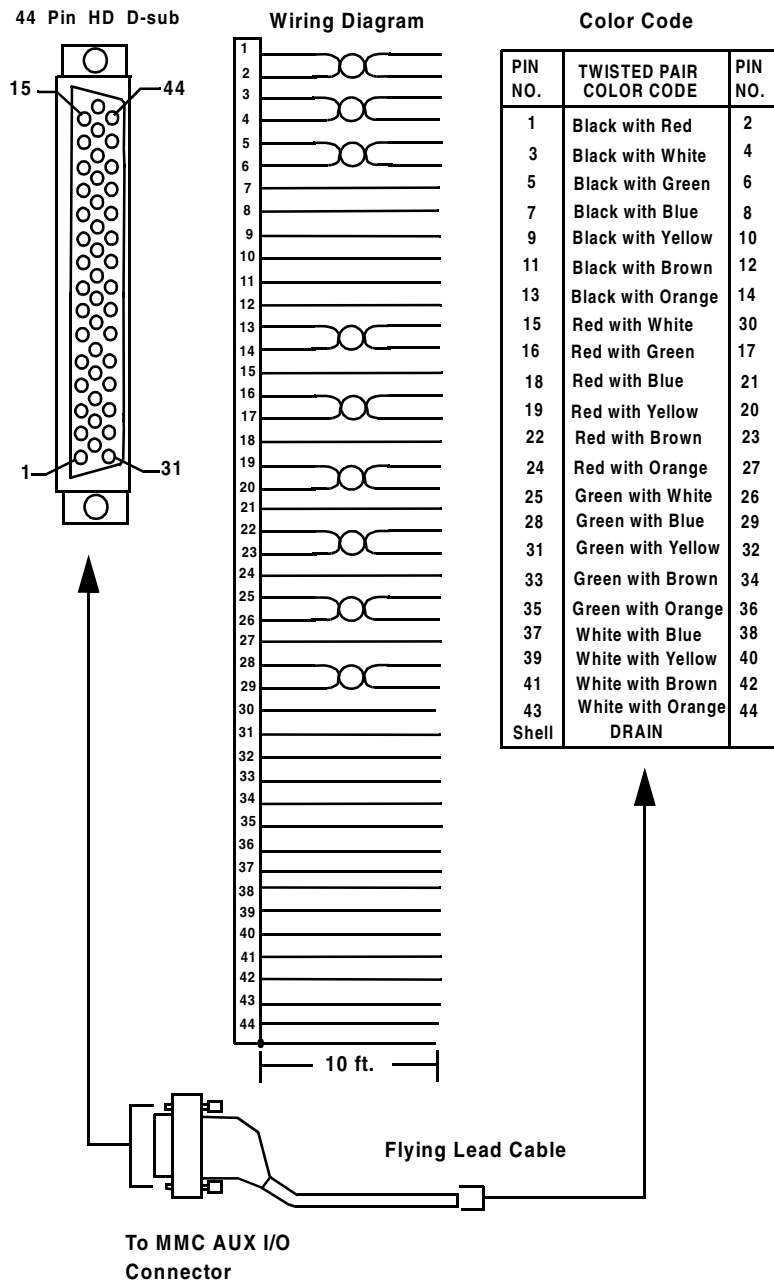

Table C1-26: Pinout - Flying Lead Cable to MMC AUX I/O Connector MMC-A4 (4 axis)

| Pin | Description | Pin | Description | Pin | Description |
|-----|-------------|-----|-------------|-------|----------------|
| 1 | A | 16 | FASTIN1+ | 31 | DCSSA |
| 2 | A/ | 17 | FASTIN1- | 32 | DCIN1 |
| 3 | B | 18 | SHIELD | 33 | DCIN2 |
| 4 | B/ | 19 | FASTIN2+ | 34 | DCIN3 |
| 5 | I | 20 | FASTIN2- | 35 | DCIN4 |
| 6 | I/ | 21 | SHIELD | 36 | DCIN5 |
| 7 | SHIELD | 22 | FASTIN3+ | 37 | DCIN6 |
| 8 | +24 VDC out | 23 | FASTIN3- | 38 | DCSSB |
| 9 | +24 VDC out | 24 | SHIELD | 39 | DCIN7 |
| 10 | COM | 25 | FASTIN4+ | 40 | DCIN8 |
| 11 | COM | 26 | FASTIN4- | 41 | DCIN9 |
| 12 | +5 VDC out | 27 | SHIELD | 42 | DCIN10 |
| 13 | ANLGIN+ | 28 | FASTIN5+ | 43 | DCIN11 |
| 14 | ANLGIN- | 29 | FASTIN5- | 44 | DCIN12 |
| 15 | SHIELD | 30 | SHIELD | Shell | Drain (shield) |

Table C1-27: Pinout - Flying Lead Cable to MMC AUX I/O Connector MMC-A2 (2 axis)

| Pin | Description | Pin | Description | Pin | Description |
|-----|-------------|-----|-------------|-------|----------------|
| 1 | A | 16 | FASTIN1+ | 31 | DCSSA |
| 2 | A/ | 17 | FASTIN1- | 32 | DCIN1 |
| 3 | B | 18 | SHIELD | 33 | DCIN2 |
| 4 | B/ | 19 | FASTIN2+ | 34 | DCIN3 |
| 5 | I | 20 | FASTIN2- | 35 | DCIN4 |
| 6 | I/ | 21 | SHIELD | 36 | DCIN5 |
| 7 | SHIELD | 22 | NC | 37 | DCIN6 |
| 8 | +24 VDC out | 23 | NC | 38 | NC |
| 9 | +24 VDC out | 24 | SHIELD | 39 | NC |
| 10 | COM | 25 | NC | 40 | NC |
| 11 | COM | 26 | NC | 41 | NC |
| 12 | +5 VDC out | 27 | SHIELD | 42 | NC |
| 13 | ANLGIN+ | 28 | FASTIN5+ | 43 | NC |
| 14 | ANLGIN- | 29 | FASTIN5- | 44 | NC |
| 15 | SHIELD | 30 | SHIELD | Shell | Drain (shield) |

3.3 Flying Lead Cable to MMC BLK I/O Connector

Table C1-28: Part No. - Flying Lead Cable to MMC BLK I/O Connector

| Description | Length | Part Number |
|--------------------------------------------|--------|-------------------------------------|
| MMC BLK I/O Connector to Flying Lead Cable | 10' | M.1016.2568 (old # 401-57313-00) |

Figure C1-20: Flying Lead Cable to MMC BLK I/O Connector

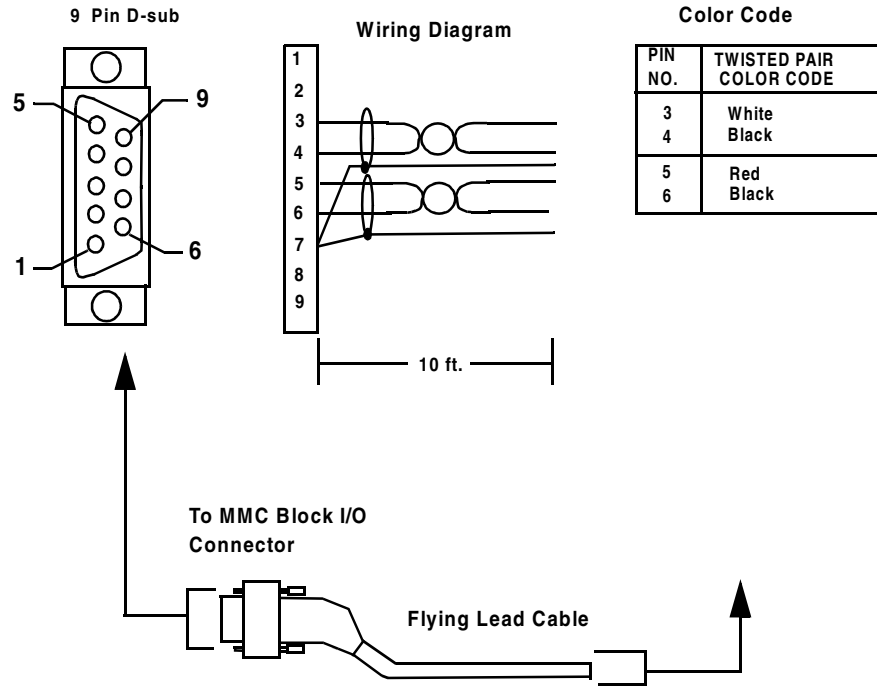

Table C1-29: Pinout - Flying Lead Cable to Block I/O Connector

| Pin | Desc. | In/Out | Pin | Desc. | In/Out | Pin | Desc. | Pin |
|-----|---------------------------|--------|-----|---------------------------|--------|-----|--------|-----|
| 1 | NC | | 4 | Block I/O Transmit Data - | Out | 7 | Shield | |
| 2 | NC | | 5 | Block I/O Receive Data + | In | 8 | NC | |
| 3 | Block I/O Transmit Data + | Out | 6 | Block I/O Receive Data - | In | 9 | NC | |

3.4 Flying Lead Cable to MMC USER PORT Connector

Table C1-30: Part No. - Flying Lead Cable to MMC USER PORT Connector

| Description | Length | Part Number |
|----------------------------------------------|--------|-------------------------------------|
| MMC USER PORT Connector to Flying Lead Cable | 10' | M.1016.2565 (old # 401-57310-00) |

Figure C1-21: Flying Lead Cable to USER PORT Connector

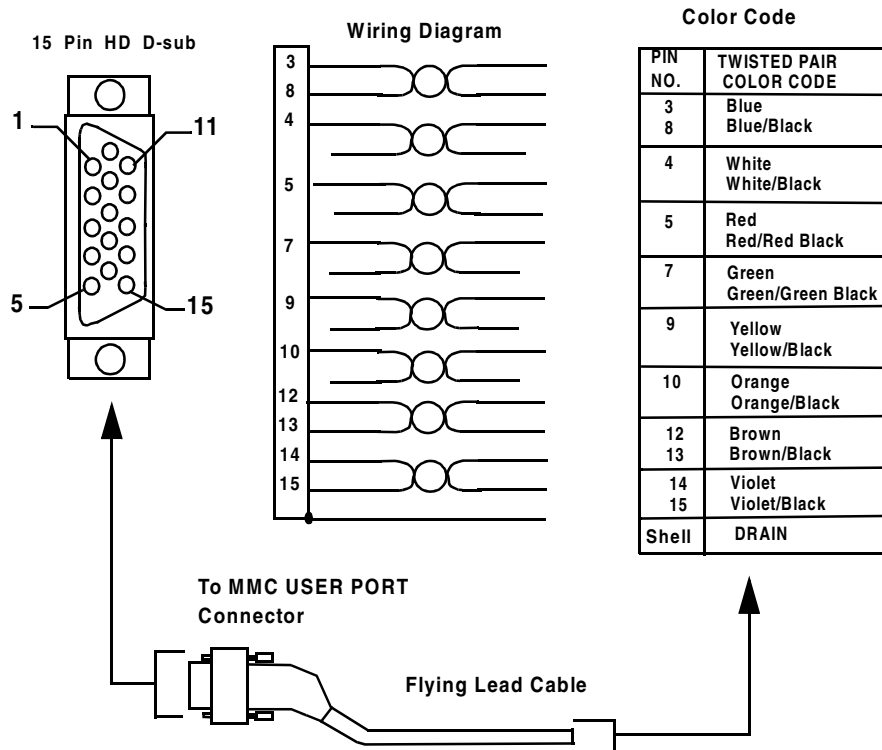

Table C1-31: Pinout - Flying Lead Cable to MMC USER PORT Connector

| Pin | Description | In/Out | Pin | Description | In/.Out |
|-----|---------------------------|--------|-------|-----------------------|---------|
| 1 | NC | | 9 | RS232 Receive Data | In |
| 2 | NC | | 10 | RS232 Transmit Data | Out |
| 3 | +5V (50mA Max) | Out | 11 | NC | |
| 4 | RS232 Data Terminal Ready | Out | 12 | RS485 Receive Data + | In |
| 5 | RS232 Request to Send | Out | 13 | RS485 Receive Data - | In |
| 6 | NC | | 14 | RS485 Transmit Data + | Out |
| 7 | RS232 Clear to Send | In | 15 | RS485 Transmit Data - | Out |
| 8 | Signal Ground | In/Out | Shell | Drain (shield) | |

3.5 Flying Lead Cable to MMC GEN I/O Connector

Table C1-32: Part No. - Flying Lead Cable to MMC GEN I/O Connector

| Description | Length | Part Number |
|--------------------------------------------|--------|-------------------------------------|
| MMC GEN I/O Connector to Flying Lead Cable | 10' | M.1016.2567 (old # 401-57312-00) |

Figure C1-22: Flying Lead Cable to GEN I/O Connector

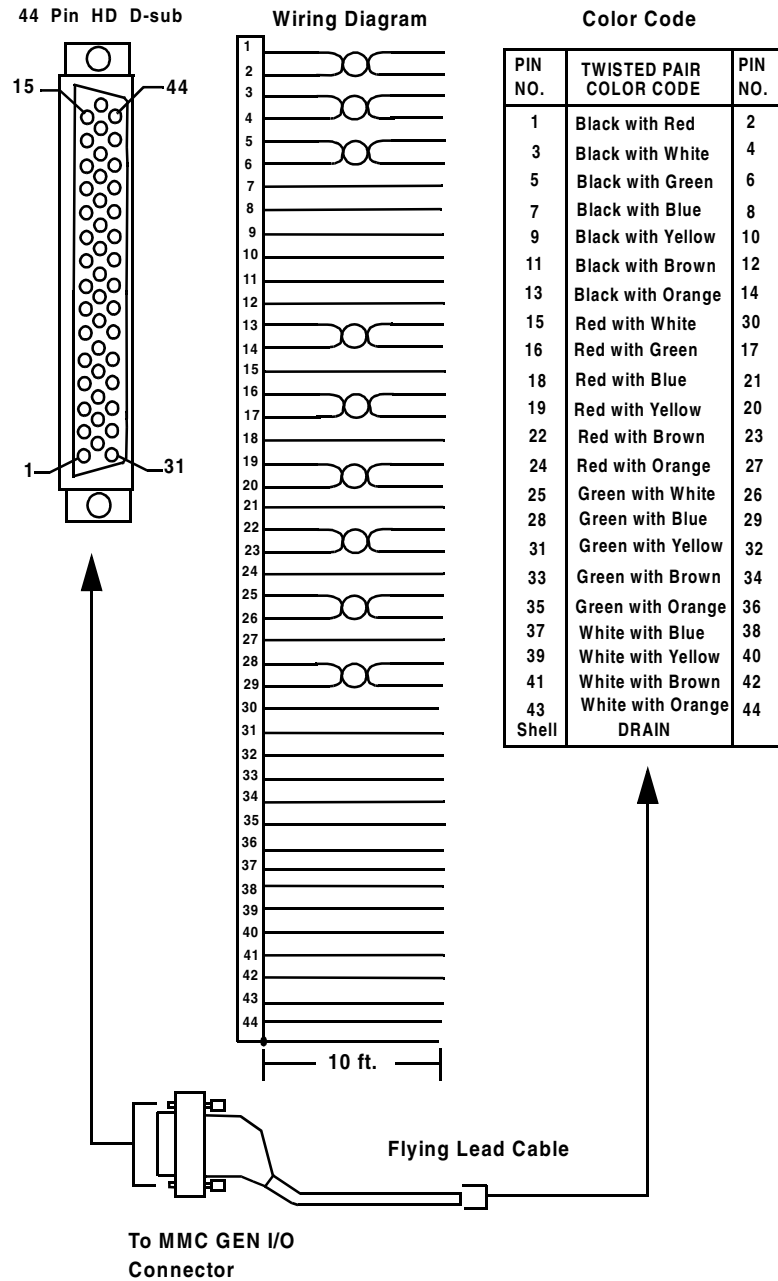

Table C1-33: Pinout - Flying Lead Cable to MMC GEN I/O Connector

| Pin | Description | In/Out | Pin | Description | In/Out | Pin | Description | In/Out |
|-----|-------------|--------|-----|-------------|--------|-------|----------------|--------|
| 1 | DCOUT1 | Out | 16 | DCOUT16 | Out | 31 | NC | |
| 2 | DCOUT2 | Out | 17 | NC | | 32 | NC | |
| 3 | DCOUT3 | Out | 18 | NC | | 33 | NC | |
| 4 | DCOUT4 | Out | 19 | NC | | 34 | IO24V | Out |
| 5 | DCOUT5 | Out | 20 | IO24V | Out | 35 | DCSS2 | In |
| 6 | DCOUT6 | Out | 21 | DCSS1 | In | 36 | IO24C | Out |
| 7 | DCOUT7 | Out | 22 | IO24C | Out | 37 | DCIN9 | In |
| 8 | DCOUT8 | Out | 23 | DCIN1 | In | 38 | DCIN10 | In |
| 9 | DCOUT9 | Out | 24 | DCIN2 | In | 39 | DCIN11 | In |
| 10 | DCOUT10 | Out | 25 | DCIN3 | In | 40 | DCIN12 | In |
| 11 | DCOUT11 | Out | 26 | DCIN4 | In | 41 | DCIN13 | In |
| 12 | DCOUT12 | Out | 27 | DCIN5 | In | 42 | DCIN14 | In |
| 13 | DCOUT13 | Out | 28 | DCIN6 | In | 43 | DCIN15 | In |
| 14 | DCOUT14 | Out | 29 | DCIN7 | In | 44 | DCIN16 | In |
| 15 | DCOUT15 | Out | 30 | DCIN8 | In | Shell | Drain (shield) | |

D.1 - MMC Profibus Module

1 Introduction

The MMC Profibus scanner module is an interface between the MMC and a Profibus network. The module contains an on-board processor, a Profibus compliant interface, and firmware that makes it act as the master to all other nodes on the network.

Prior to initial operation, a file is generated with specific configuration software in an external PC. This file must be downloaded via the RS232 configuration port to the Profibus module prior to initial operation. Two indicator LEDs (IN/OUT) are connected to this configuration port.

Directly above the Profibus port are two LEDs that provide operation information: Network Status and Profibus Scanner Status.

The DIAG LED goes on briefly while the diagnostic tests are running.

Figure D1-1. MMC Profibus Module

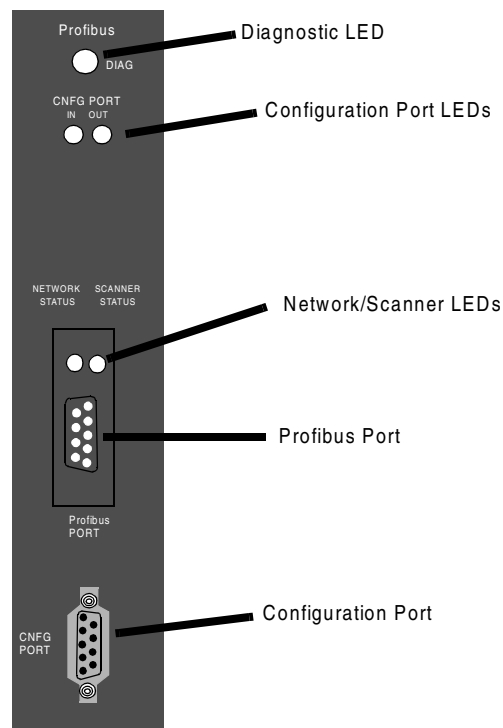

2 Connections

Profibus connections are illustrated in Figure D1- 2. Up to 125 Profibus Nodes may be attached to the Profibus scanner module.

Figure D1-2. Profibus Connections

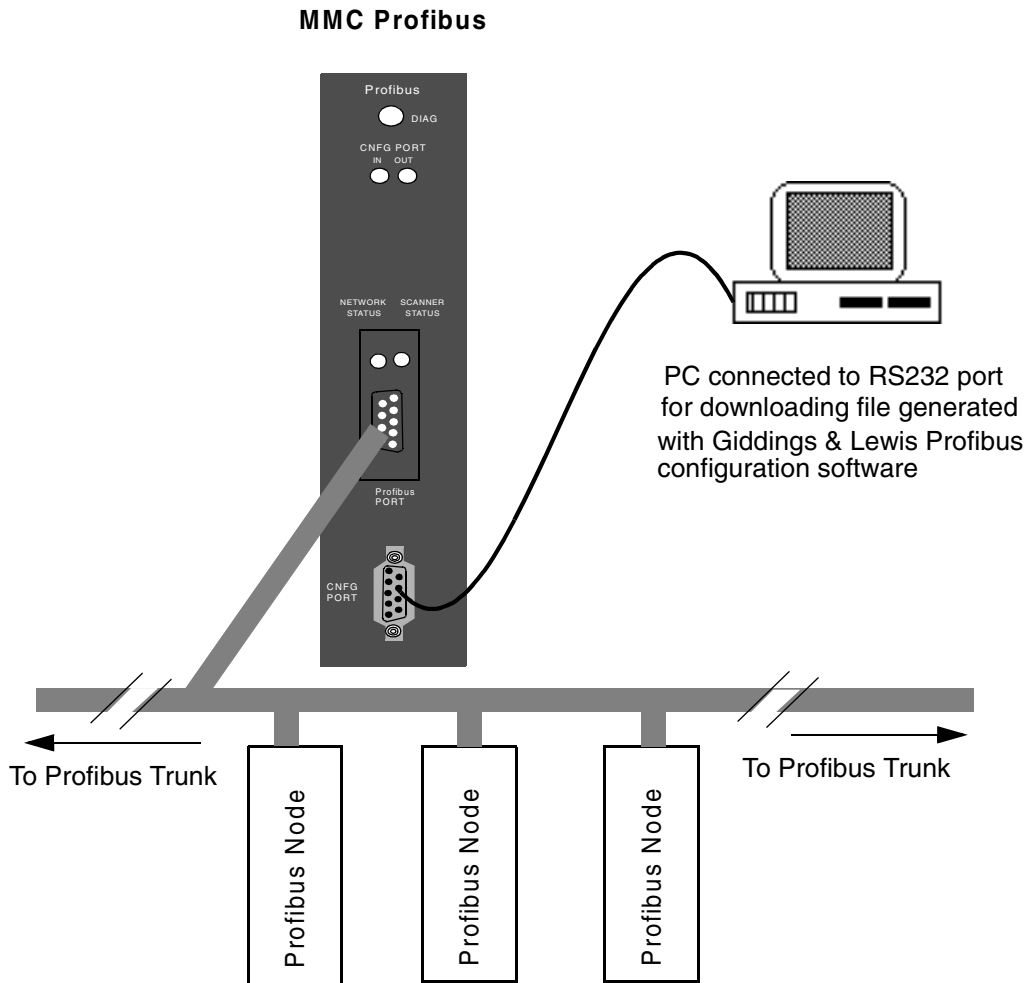

2.1 The Profibus Port

The Profibus port is on the front of the module near the center as shown in Figure D1- 1. The pinout for the Profibus port is shown below:

| Pin # | Signal Name | Note: |
|-------|-----------------|--------------------------------------------------------------------------------------------------------------------------------------------------------------------------------------------------------------------------------------------------------|
| 1 | Chassis ground | It is strongly recommended that you use Profibus Sub-D connectors with switchable (ON/OFF) termination, such as Siemens 6ES7 972-0BA11-0XA0 or 6ES7 972-0BB11-0XA0. Only use Profibus type A cable, such as Belden 3079A or Siemens 6XV1 830-0AH10. |
| 2 | reserved | |
| 3 | data + | |
| 4 | Tx enable | |
| 5 | Isolated ground | |
| 6 | voltage plus | |
| 7 | reserved | |
| 8 | data - | |
| 9 | reserved | |

2.2 The Configuration (RS232) Port

There is an RS232 port on the lower front of the module as shown in Figure D1- 1. This is used to connect to a PC in order to download a file representing your Profibus network.

| Pin # | Signal Name | In/Out |
|-------|---------------|--------|
| 2 | Receive Data | In |
| 3 | Transmit Data | Out |
| 5 | Ground | In/Out |

3 LEDs

The two configuration port LEDs and the two Profibus port LEDs are described below.

| | LED | Color | State | Definition | |
|----------------------|---------------------------|------------|----------|------------------------------------------------------------------------------|--------------------------------------|
| Profibus Port | Network status | None | OFF | Off-line | |
| | | Green | ON | On-line and connected to at least one node | |
| | | | Flashing | On-line but connection nodes not established | |
| | | Red | ON | Unrecoverable Fault (duplicate MAC ID check failed, critical bus fault etc.) | |
| | | | Flashing | I/O connections in timed-out state or other Recoverable Fault | |
| | Scanner status | Green | OFF | No power or else reset asserted | |
| | | | ON | Scanner OK and active | |
| | | | Flashing | Scanner OK but not active | |
| | | Red | ON | Hardware or software error | |
| | | | Flashing | Recoverable configuration error (invalid data downloaded) | |
| | | Orange | ON | Configuration (download) mode | |
| | Configuration Port | IN | Red | Flickering | Data is being passed to the module |
| | | | | OFF | No data to the module |
| | | OUT | Red | Flickering | Data is being passed from the module |
| | | | OFF | No data from the module | |

4 Theory of Operation

The Profibus scanner module provides a memory image of the nodes (slaves) connected to a Profibus network. It is this memory image that is controlled by your LDO created in PiCPro. The module's on-board processor continually transfers data between this memory image and the actual Profibus nodes.

Communication between the Profibus module and the nodes can be set between 9600 baud (1200m max.) and 12M baud (100m max.). The baud rate, the relationship between the memory image and specific data in each node, and other parameters are established with configuration software run in an external PC.

This configuration software generates two files. One file is downloaded to the Profibus module through its RS232 serial port. The other file is used by PiCPro to establish the relationship between the memory image and the declared variables in the LDO. To ensure that a given location in the memory image is connected to a variable in the LDO and to the corresponding data in the Profibus node, the same tag name or label must be used.

For example, when running the configuration software, PROX_SW1 could be used as the name for a boolean bit of a Profibus Block I/O. It would correspond to the wiring location of a proximity switch. The name PROX_SW1 must also be used for the corresponding variable in your LDO.

NOTE

The G&L Profibus configuration software (G&L Part No. M.1300.7794) is required to configure the Profibus scanner (within the Profibus module) for the devices on the associated network.

NOTE

Additional information about Profibus can be obtained at www.profibus.com

5 Specifications

| Characteristics | Profibus Module Specifications |
|-----------------------------|----------------------------------------------------------------------------------------------------------------------------------------------------------------------------------------------------------------------------------------------------------------------------------------------------------------------------------------------------------------------------------------------------------------------------------------------------------------------------------------------------------------------------------------------------------------------------------------------------------------------------------------------------------------------------------------------------------------------------------------------------------------------------------------------------|
| Function | Interfaces to a Profibus network with up to 125 other nodes (acts as DP Master - Class 1) |
| Part number | M.1300.7167 |
| Profibus Port | 9-pin female D-sub connector |
| Configuration Port | RS232 interface |
| 24 V DC Power from the MMC | 100 mA |
| Operating temperature range | 7° C to 55° C (45° F to 131° F) |
| Storage temperature range | -40° C to 85° C (-40° F to 185° F) |
| Humidity | 5 to 95%, non-condensing |
| CE Marked | <p>Conforms to Directives 73/23/EEC, 89/336/EEC, 92/31/EEC, 93/68/EEC by conforming to the following standards:</p> <p>EN 50081-2:1993 EMC Generic Industrial Emissions EN 50082-2:1995 EMC Generic Industrial Immunity EN 61131-2:1994/A11:1996 Low voltage directive requirements for programmable controllers</p> <p>Operates with emissions below EN55011/ CISPR 11 Class A limits</p> <p>Immune to:</p> <ul style="list-style-type: none"> • Electrostatic discharge (4K V contact mode, 8K V air discharge) per EN61000-4-2 • RF electromagnetic fields per EN61000-4-3, ENV 50141, and ENV50204 • Electrical fast transients per EN61000-4-4 • Magnetic fields per EN61000-4-8 <p>Refer to the EMC Guidelines for more information.</p> |
| UL and C/UL Listed | File No. E126417 NRAQ Programmable Controllers |
| Physical size | 1.3" wide x 9.6" high x 5.3" deep 33 mm x 244 mm x 135 mm |
| Vibration (per IEC 68-2-6) | 10-57 Hz (constant amplitude .15 mm) 57 - 2000 Hz (acceleration 2 g) |
| Shock (per IEC 68-2-27) | Four shocks per axis (15g/11 msec) |

E.1 - CE and EMC Guidelines

| NOTE |
|--------------------------------------------------------------------------------------------------------------------------------------------------------------------------------------------------------|
| The CE mark on PiC products assures compliance with both the EMC and low voltage European directives. Prior to this CE mark, EMC on the product label only assured compliance with the EMC directives. |

1 Background on EMC (Electromagnetic Compatibility) Compliance

In order to market products in the European Union after January 1, 1996, an electromagnetic compatibility directive (EU Directive 89/336/ECC) must be met. All products must be designed and manufactured in such a way that:

1. Electromagnetic disturbances generated by the products do not cause interference to other systems.
2. The performance of the product is not affected by electromagnetic disturbances within the environment in which the product is intended to operate.

The directive refers to relevant harmonized European EMC standards against which product conformity can be assessed, although other methods of assessment, notably the preparation of a Technical File, are permissible. The equipment manufacturer or the manufacturer's agent in the Community must make a Declaration of Conformity and can place the CE mark on the product. Failure to conform with the requirements of the directive can result in a total ban on sales throughout the Single Market and legal action could be taken against the signatory of a false declaration of conformity.

2 Background on Low Voltage Compliance

In order to market products in the European Union after January 1, 1997, the low voltage directive (EU Directive 73/23/EEC) must be met.

The intention of the directive is to assure user safety under normal operating and fault conditions. The directive includes the use of certain warning labels and user instructions. It establishes limits to prevent electrical shock hazard, overheating and fire.

3 RFI Emission and Immunity

The EMC product characteristics are classified by the emission and immunity performance.

Emissions not only include radiated noise from the product enclosure and cabling, but also that which is conducted away from the product along the cables connected to it. This may be subsequently radiated from the cable or conducted directly into another product which shares this cable e.g. the main AC supply.

Immunity is how susceptible a product is (e.g. to the radiated and conducted emissions from the product mounted next to it). To ensure compatibility, the immunity of a product must always exceed the expected emissions in the environment in which it operates as is shown in the diagram below. This is to ensure a margin of safety.

Figure 1 Safety Margin

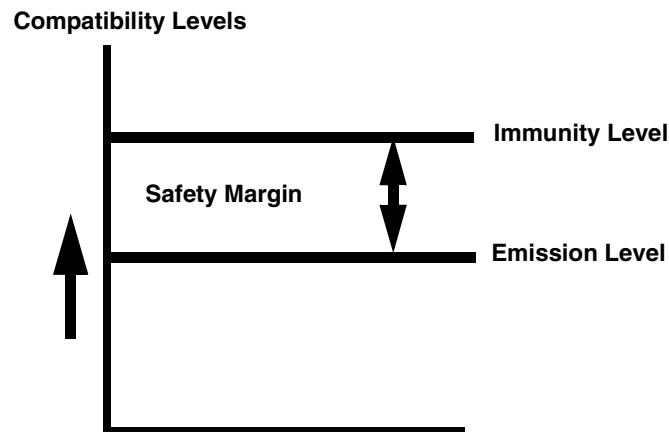

In addition to conducted and radiated immunity, products must also be capable of withstanding:

1. Electro-static discharges (ESD)
2. Conducted fast transient voltages

The discharge spark generated from ESD can easily damage electronic components. The conducted fast transient voltages are induced in cables laid in close proximity to other cables in which large inductive loads are switched (such as relays, contactors, and AC motor starters). This is a good example of what can happen to sensitive control and signal cabling connected to drives when poorly installed in enclosures on industrial sites.

4 Classes of EMC Operating Environments

Before the correct level of EMC can be designed into equipment, the EMC operating environment must be defined. For example in industrial locations where high power equipment is in use, high levels of background electrical noise would be expected when compared to a household or office environment. Since it is more expensive to reduce the emissions from higher power equipment than to increase the immunity, the emission limits allowed in industrial environments are higher than for household or office environments. Vice versa for immunity because of the higher emission limits in industrial environments, the immunity requirements are more strict than for the household or office environment. Hence in order to achieve EMC between different equipment, it is essential to know what EMC operating environment it is to be installed in, and to compare the installation environment to the environment for which it was designed.

Today using generic EMC standards, two environments are defined:

1. Industrial
2. Residential, commercial, and light industrial

The environments are locations defined on the basis of whether the AC supply is shared with other locations or is buffered from them with a distribution transformer. If your location is buffered via a distribution transformer, then you are in an industrial environment. If you share your AC supply with a neighboring location, then you are in a residential, commercial, or light industrial environment. For example, an industrial unit which shares its AC supply with a neighboring unit is defined as a residential, commercial, and light industrial location. If it is supplied from its own distribution transformer, then it is an industrial location.

5 Conformance with the EMC Directive

Giddings & Lewis will be complying to the Directive by self-certification to the following generic EMC standards:

1. EN50081-2 for industrial emissions using EN55011 (based upon CISPR 11A)
2. EN50082-2 for industrial immunity using:
 - IEC 61000-4-2 (ESD- 4KV contact mode, 8 KV air discharge)
 - IEC 61000-4-3 (Radiated susceptibility)
 - IEC 61000-4-4 (Electrical fast transient)
 - IEC 6100-4-8 (Magnetic fields)

A statement of compliance will be made with the letters "EMC" or "CE" on the product, but will be valid only if the product is installed properly.

6 Conformance With the Low Voltage Directive

Giddings & Lewis will comply with the Directive by self certification to the following standard:

EN 61131-2:1994/A11:1996 Low Voltage Requirements for Programmable Controllers

A statement of compliance will be made with the letters "CE" on the product but will be valid only if the equipment is properly installed.

7 Changes to the PiC Products

Giddings & Lewis PiC products had originally been designed with a high level of noise immunity and tested according to standards such as NEMA showering arc and the original version of IEC 801-2. However, the EU directive for immunity requires testing to standards that have more variables and are more repeatable. The directive also requires control of emissions, something that is not regulated in U. S. industrial environments.

As a result, changes have been made to the hardware modules within the PiC product line. The changes have included the addition of filtering, re-routing of foils and/or the addition of ground planes to printed circuit boards, use of some conductive enclosures, provision for shielded wires* for peer-to-peer communication, and internal connection of SPG to field side connectors.

*NOTE

A recommended shielded wire is Belden, 24 AWG (7X32), 9729

7.1 Changes Affecting the User

Many of the changes Giddings & Lewis has implemented are transparent to the user. However, there are some changes affecting user installation.

Giddings & Lewis continues to recommend separation of low level signals (encoder, analog, communications, fast DC inputs) from high voltage or high current lines from any of the above. More specifically, maintain *at least* one inch of separation around encoder signals and around communication signals.

It is no longer necessary to connect a wire from a module to SPG. This user-installed wire had been a source of emissions and thus the connection should not be made. Analog modules typically had this requirement in the past.

To prevent excessive conducted emissions from a DC power source (typically 24V) used for digital I/O, a 1000 picofarad capacitor should be used. Connect the capacitor from the +24V DC to COMMON at the distribution terminals. The same applies to any other external DC power source used with the PiC product.

The figure on the left below illustrates the connection method *before* EMC compliant products were available. The figure on the right illustrates the recommended connections when using EMC compliant products. On the right, note that the SPG connection has been eliminated and that a capacitor is connected to the 24V DC supply.

Figure 2 Connections for EMC Compliance

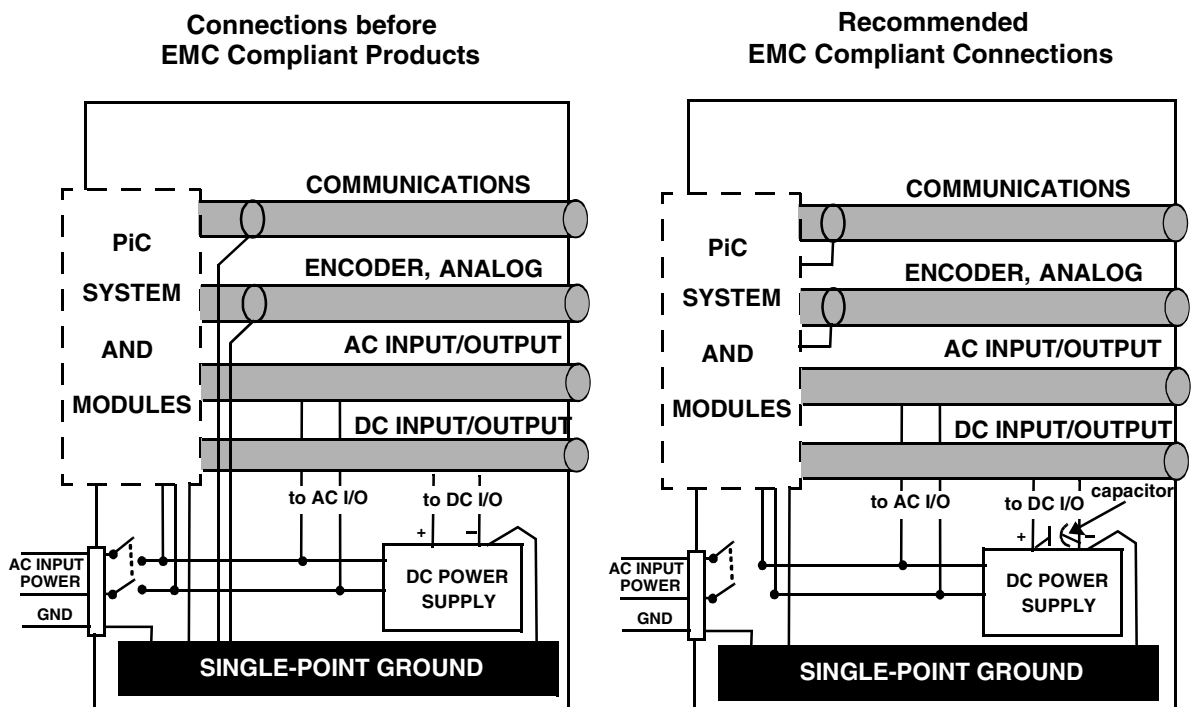

There is now a provision for shield termination to the CPU modules for peer-to-peer communication. Shielded cable must be used to reduce emissions.

Inside a control cabinet, the practice of connecting the shields of shielded cables at the modules should be continued. For an example of a shielded cable entering/leaving the cabinet see Figure 3.

Figure 3 Connecting Shielded Cable

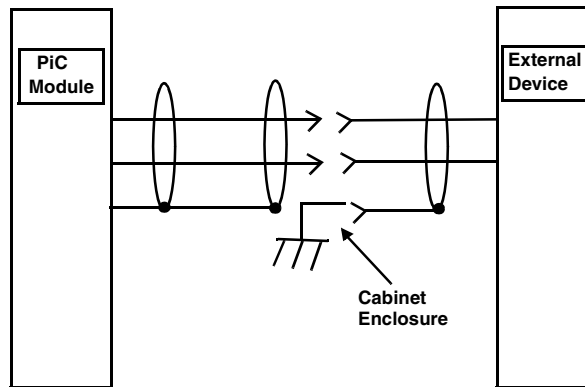

The two different methods of terminating shields are used to accommodate two different immunity requirements. Immunity required inside an enclosure is considered lower because cables are typically less than 3 meters in length and/or can be separated from each other and from noise sources.

Immunity required external to an enclosure is considered higher because the user may have less control over the noise environment. Low level signal cables that can be external to an enclosure and AC/DC digital I/O cables have been tested at a 2 KV level for electrical fast transients (EFTs). Low level signals that can be less than 3 meters in length or can be separated from noise sources are tested at a 1 KV level.

Under the stated conditions, there will be no disturbance of digital I/O, encoder, or stepper operation. For analog signals, there may be momentary disturbances but there will be self-recovery when the noise subsides.

In order to meet the EU directive requirement for emissions and immunity, fiber optics must be used for I/O expansion.

Although the control will pass the electrical fast transient test on incoming power lines, users may still want to use a power line conditioner.

As a general precaution, do not operate transmitters, arc welding equipment, or other high noise radiators within one meter of a PiC enclosure that has the door open. Continue to equip inductive devices, if they are in series with a mechanical contact or switch, with arc suppression circuits. These devices include contactors, solenoids and motors. Shield all cables that carry heavy current near the system, using continuous foil wrap or conduit grounded at both ends. Such cables include power leads for high-frequency welders and for pulse-width-modulated motor drives. .

NOTE

Shields for signal wires are grounded at only one end, to provide immunity to outside noise sources. However, the shields for "noise sources" are grounded at both ends, to reduce emissions and "contain" the noise.

Worst case tests with analog I/O modules have caused momentary disturbances no greater than .5V in a +10V to -10V range and .5 mA in a 4 to 20 mA range. Worst case tests with an RTD module have caused momentary disturbances no greater than + or -4°C in a range of -200° to 266°C. Worst case tests with a JK thermocouple module have caused momentary disturbances no greater than + or - 1 mV over a 100 to 1.

NOTE

To assure compliance with the low voltage directive, it is necessary to follow installation instructions in the controller Hardware Manual. Also refer to any instructions specific to individual control modules.

8 Using EMC and Non-EMC Modules

IMPORTANT

Failure to follow these guidelines may result in undesired system performance.

There are several issues that must be considered when using EMC compliant and Non-EMC compliant Modules. This document addresses these issues.

Module Identification - To determine whether a module is EMC or Non-EMC, look at the gray Unit Tag located on the side of the plastic module case. EMC modules will have “EMC” or “CE” printed under the “MAX. AMBIENT TEMP.” specification. Non-EMC will not have “EMC” or “CE” printed in this location.

Grounding - Due to differences in shielding requirements, it is extremely important to follow proper shielding guidelines for a given module. Failure to do so may result in intermittent operation in noisy environments. For modules that have an SPG terminal and/or one or more SHIELD terminal, perform the following:

- For EMC modules, do not connect the SPG terminal or SHIELD terminals to the system’s Single Point Ground
- For Non-EMC modules, connect the SPG terminal, or a SHIELD terminal, to the system’s Single Point Ground

EMC CSM and RSM Modules - Using an EMC CSM, RSM, or CSM/CPU (PiC90) with certain Non-EMC analog modules may cause intermittent operation. Follow these guidelines for determining the type of CSM, RSM, or CSM/CPU that should be used in a particular rack:

If your rack contains one or more Non-EMC modules that perform D/A conversion or provide an Encoder interface, you must use a non-EMC CSM, RSM, or CSM/CPU (PiC90).

If your rack contains one or more Non-EMC modules that perform D/A conversion or provide an Encoder interface, you must use a non-EMC CSM, RSM, or CSM/CPU (PiC90).

If your rack does not contain one or more Non-EMC modules that perform D/A conversion or provide an Encoder interface, you may use either an EMC or Non-EMC CSM, RSM, or CSM/CPU (PiC90).

NOTE

All modules and backplanes must be EMC compliant for a system to be EMC compliant.

9 Declarations of Conformity

EMC Directive and Low Voltage Directive DECLARATION OF CONFORMITY

Application of Council Directives 73/23/EEC, 89/336/EEC, 92/31/EEC, 93/68/EEC

Manufacturer's Name: Giddings & Lewis Controls, Measurement, and Sensing
 Manufacturer's Address: 660 South Military Road
 Fond du Lac, Wisconsin 54936-1658

European Representative Name: Cross Hüller
 European Representative Address: Randles Road, Knowsley Industrial Park
 Prescott, Merseyside L34 9EZ England

Herewith declares that all **PiC900™/PiC90™/ PiC9™ and Block I/O modules** listed below,

| | | | | |
|-----------------|-----------------|-----------------|-----------------|-----------------|
| 502-03512-03,07 | 502-03674-02,22 | 502-03839-04 | 502-04030-00 | 503-25154-02 |
| 502-03518-03,23 | 502-03674-42 | 502-03840-04,24 | 502-04050-00 | 503-25187-01,11 |
| 502-03548-00 | 502-03676-03,23 | 502-03840-44 | 502-04073-20 | 503-25188-01,11 |
| 502-03549-02 | 502-03677-02,22 | 502-03842-02 | 502-04077-00,20 | 503-25189-01,11 |
| 502-03550-02,06 | 502-03677-42 | 502-03843-02 | 502-04077-40 | 503-25758-01,11 |
| 502-03551-03,08 | 502-03679-02 | 502-03846-X3 | 502-04104-01,11 | 503-25906-01 |
| 502-03552-02,22 | 502-03681-02,07 | 502-03853-X3 | 502-04110-00,10 | 503-25907-01 |
| 502-03605-00,05 | 502-03692-03 | 502-03876-02 | 502-04111-01,11 | 503-25908-01 |
| 502-03640-02,07 | 502-03698-22 | 502-03882-XX | 502-04112-01,11 | 503-25909-01 |
| 502-03641-03,08 | 502-03722-02 | 502-03907-03 | 502-04125-01,11 | 503-25910-01 |
| 502-03642-03,08 | 502-03732-03,07 | 502-03944-XX | 502-04125-00,10 | 503-25936-01 |
| 502-03643-00 | 502-03782-02,22 | 502-03947-00 | 503-13704-00 | 503-25947-01 |
| 502-03644-03 | 502-03786-02,22 | 502-03956-02 | 503-18009-03,08 | 503-25988-01 |
| 502-03651-00 | 502-03809-02 | 502-03963-X1 | 503-18010-03,08 | X = 0 → 2 |
| 502-03657-03,07 | 502-03810-03 | 502-03973-00 | 503-18011-03,08 | |
| 502-03658-02 | 502-03813-03,07 | 502-03994-X1 | 503-19184-02 | |
| 502-03673-00 | 502-03817-03,07 | 502-04011-X1 | 503-19185-02 | |

when installed in accordance with the instructions contained in the "PiC900 Hardware Manual" (P/N 401-54514-00), conform to the following generic and basic standards.

- | | |
|--------------------------|-------------------------------------------------------|
| EN 50081-2:1993 | EMC Generic Industrial Emissions |
| EN 50082-2:1995 | EMC Generic Industrial Immunity |
| EN 61131-2:1994/A11:1996 | Low voltage requirements for programmable controllers |

Future modules (with higher P/N's) labeled with the CE mark will also conform to these standards.

We, the undersigned, hereby declare that the equipment specified above conforms to the above directive(s).

Legal Representative in Europe

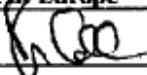
| | |
|-----------|-------------------------------------------------------------------------------------|
| Signature |  |
| Full Name | Roger M. Collins |
| Position | Managing Director |
| Place | Cross Hüller |
| Date | OCT 18 99 |

**EMC Directive and Low Voltage Directive
DECLARATION OF CONFORMITY**

Application of Council Directives 73/23/EEC, 89/336/EEC, 92/31/EEC, 93/68/EEC

Manufacturer's Name: Giddings & Lewis Controls, Measurement, and Sensing
Manufacturer's Address: 660 South Military Road
Fond du Lac, Wisconsin 54936-1658

European Representative Name: Cross Hüller
European Representative Address: Randles Road, Knowsley Industrial Park
Prescot, Merseyside L34 9EZ England

Herewith declares that all MMC (Machine and Motion Control) units listed below,

503-26606-XX, 503-26683-XX, 503-26684-XX, 503-26842-XX → 503-26856-XX
(X = 0 → 9)

and approved cables and accessories, when installed in accordance with the instructions contained in the "MMC Hardware Manual" (P/N 108-31050-00), conform to the following generic and basic standards.

| | |
|--------------------------|-------------------------------------------------------|
| EN 50081-2:1993 | EMC Generic Industrial Emissions |
| EN 50082-2:1995 | EMC Generic Industrial Immunity |
| EN 61131-2:1994/A11:1996 | Low voltage requirements for programmable controllers |

MMC units bear the CE mark to indicate conformance to these standards.

We, the undersigned, hereby declare that the equipment specified above conforms to the above directive(s).

Legal Representative in Europe

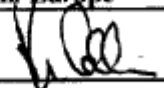
| | |
|-----------|-------------------------------------------------------------------------------------|
| Signature |  |
| Full Name | Roger M. Collins |
| Position | Managing Director |
| Place | Cross Hüller |
| Date | OCT 18 99 |

**EMC Directive and Low Voltage Directive
DECLARATION OF CONFORMITY**

Application of Council Directive(s) 73/23/EEC, 89/336/EEC, 92/31/EEC, 93/68/EEC

Manufacturer's Name: Giddings & Lewis Controls, Measurement, and Sensing
 Manufacturer's Address: 660 South Military Road
 Fond du Lac, Wisconsin 54936-1658

European Representative Name: Cross Hüller
 European Representative Address: Randles Road, Knowsley Industrial Park
 Prescot, Merseyside L34 9EZ England

Herewith declares that all servo drives listed below,

| Model Name | Part Number | Model Name | Part Number | Model Name | Part Number |
|------------|--------------|------------|--------------|----------------|--------------|
| DSM110 | 401-34400-00 | DSM030 | 401-56453-00 | DSM015P | 401-56452-50 |
| DSM120 | 401-34401-00 | DSM110P | 401-34400-50 | DSM030P | 401-56453-50 |
| DSM130 | 401-34402-00 | DSM120P | 401-34401-50 | DSM110 SERCOS | 401-30277-00 |
| DSM175 | 401-34403-00 | DSM130P | 401-34402-50 | DSM120 SERCOS | 401-30278-00 |
| DSM1150 | 401-34404-00 | DSM175P | 401-34403-50 | DSM130 SERCOS | 401-30279-00 |
| DSM007 | 401-56451-00 | DSM1150P | 401-34404-50 | DSM175 SERCOS | 401-30280-00 |
| DSM015 | 401-56452-00 | DSM007P | 401-56451-50 | DSM1150 SERCOS | 401-30281-00 |

when operating any of the following motor families,

SSM, HSM, NSM, YSM and FSM

when operating with or without the optional Touch Pad,

P/N 401-34405-00

and when installed in accordance with the installation instructions contained in the "Centurion DSM100 Drive Hardware and Installation Manual" (P/N 108-30083-00), or "MicroDSM Installation Manual" (P/N 108-31017-00), conform to the following generic and basic standards.

- EN 55011:1993 (CISPR 1) Group 1 class A
- EN 50082-2:1995 EN 61000-4-2, ENV 50140, ENV 50204, EN 61000-4-4, ENV 50141, EN 61000-4-8
- EN 60204:1993

We, the undersigned, hereby declare that the equipment specified above conforms to the above directive(s).

Legal Representative in Europe

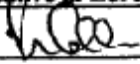
| | |
|-----------|-------------------------------------------------------------------------------------|
| Signature |  |
| Full Name | Roger M. Collins |
| Position | Managing Director |
| Place | Cross Hüller |
| Date | OCT 18 99 |

NOTES

Index

Numerics

10Base T connection A.1-3

24-bit latch 69

24-bit up/down counter 69

A

analog input

theory of operation 70

analog output

theory of operation 67, 71

analog output to drive connections 50

analog servo module 13

application

in flash 62

wiring 31

auxiliary I/O

connector 52

general purpose inputs 55

pinout 52

available I/O 13, 14

axis connectors

pinout 47

axis DC input to drive ready connection 50

B

battery

disposal 75

LED 60

position 74

replacement 73

type 75

block I/O port

pinout 40

breakout box 39

breakout box and cables

Auxiliary I/O C.1-6

Auxiliary I/O with encoder isolators
C.1-9

Axis connector C.1-3

block I/O C.1-15

GEN I/O connector C.1-21

User port C.1-18

C

cables 39

centurion drive cable

DSM J1 to MMC Axis connector C.1-25

MicroDSM J1 to MMC Axis connector

C.1-27

codes

diagnostic error 61

communications

DeviceNet B.1-1

Ethernet-TCP/IP A.1-1

Profibus D.1-1

configuration

sink 48

source 48

configuration port B.1-4, D.1-4

configuration port LEDs

LEDs D.1-4

connection

10BaseT A.1-3

connection selector sheet

mmc analog control C.1-1

MMC SERCOS control C.1-2

connections

analog output to drive 50

axis DC input to drive 50

DeviceNet B.1-2

EMC E.1-5

encoder inputs to drive encoder output 51

Ethernet-TCP/IP A.1-2

fast inputs 54

general outputs 43

general purpose inputs 44

MMC analog servo module 47, 57

MMC CPU module 39

Profibus D.1-2

connector

auxiliary I/O 52

axis 47

block I/O 40

general I/O 42

PiCPro 39

power 45

user port 41

control cabinet

requirements 23

specifications 23

CPU 13

current

leakage 66

D

DC input

- theory of operation 65
- DeviceNet B.1-1
 - baud rates B.1-5, D.1-5
 - configuration software B.1-5, D.1-5
 - connections B.1-2
 - LEDs B.1-4
 - port B.1-3, D.1-3
 - proximity switch B.1-5
 - specifications B.1-6
 - theory of operation B.1-5
- diagnostic
 - error codes 61
 - LED 37, 60
 - power-on 37
 - run-time 38
 - troubleshooting 37
- Diagnostics 37
- differential devices 33
- dimensions
 - mounting 17, 21
- directive
 - EMC E.1-1
- distribution
 - power 25
- download hex 35, 62
- E**
 - electrical service & maintenance safety 9
 - electromagnetic compatibility E.1-1
 - electro-static discharge E.1-2
 - EMC E.1-1
 - conformance E.1-4
 - directive E.1-1
 - operating environments E.1-3
 - PiC products E.1-4
 - using EMC and Non-EMC modules E.1-8
 - EMC connections E.1-5
 - EMC Guidelines E.1-1
 - encoder
 - error detection 33
 - quadrature 13, 68
 - theory of operation 68
 - encoder inputs to drive encoder output connections 51
 - environment requirements

- system 23
- error codes
 - diagnostic 61
- ESD E.1-2
- ethernet
 - RS232 ports A.1-4
- Ethernet-TCP/IP A.1-1
 - connections A.1-2
 - internet links A.1-8
 - LEDs A.1-5
 - specifications A.1-7
 - specifications (IEEE 802.3) A.1-2
 - theory of operation A.1-6

F

- fast input 69
 - characteristics 69
 - connection 54
 - sink configuration 54
 - source configuration 54
- fast transient voltage E.1-2
- faults
 - diagnostic 61
- firmware
 - MMC Ethernet module A.1-5
- flash memory 75
- flying lead cables
 - flying lead cable to MMC USER PORT connector C.1-34
 - flying lead to MMC AUX I/O connector C.1-30
 - flying lead to MMC Axis connector C.1-29
 - flying lead to MMC BLK I/O connector C.1-33
 - flying lead to MMC GEN I/O connector C.1-35

G

- general I/O
 - port pinout 42
- general inputs
 - sinking/sourcing 44
- general outputs
 - connections 43
- general purpose inputs

- connections 44
- grounding
 - protective earth 6
 - system 28

H

- heat control
 - MMC system 29
- hex
 - download 35, 62

I

- I/O 13, 14
- IEC 65
- inductive load
 - internal diode 63
 - protection from 63
- inspection
 - safety 8
- internal diode
 - and inductive loads 63
- internet links
 - Ethernet-TCP/IP A.1-8

K

- key
 - Remote Programmer Access A.1-1
- kickback 63

L

- latch
 - 24-bit 69
 - counter value 69
- LEDs
 - battery 60
 - DeviceNet B.1-4
 - diagnostic 37, 60
 - error codes 61
 - Ethernet-TCP/IP A.1-5
 - power 37, 60
 - Profibus D.1-4
 - scan 37, 60
 - troubleshooting 37

M

- manual cleaning procedure 10
- MMC

- analog servo module
 - connections 47, 57
- connecting to an application 35
- CPU
 - module connections 39
 - theory of operation 62
- handling 30
- models 11
- operating limits 29
- overview 11
- ports 12, 59
- power 25
- SERCOS control
 - connection selector sheet C.1-2
 - Servo Control Unit 12, 59
 - specifications 75

models

- MMC 11
- module 13
 - analog servo 13

modules

- DeviceNet B.1-1
- Ethernet-TCP/IP A.1-1
- Profibus D.1-1
- SERCOS 71

mounting

- dimensions 17, 21
- instructions 17

O

- operation
 - safety 8
 - startup 35
- overview
 - MMC 11

P

- peak reverse voltage 63
- PiCPro
 - cable pinout 39
 - port pinout 39
- pinout
 - auxiliary I/O 52
 - axis connector 47
 - block I/O port 40
 - general I/O port 42

- PiCPro cable 39
- PiCPro port 39
 - user port 41
- plug and play products C.1-1
- port
 - configuration B.1-4
 - DeviceNet B.1-3, D.1-3
 - SERCOS 57
 - serial 58
- power
 - connection 45
 - distribution
 - basic 24
 - distribution in MMC 25
 - LED 37
 - switch
 - MMC 25
- power requirements
 - system 23
- power supply
 - sizing worksheet 26
- power-on diagnostics 37
- procedure
 - manual cleaning 10
 - mounting 17
 - replacing battery 73
- Profibus D.1-1
 - connections D.1-2
 - LEDs D.1-4
 - specifications D.1-6
 - theory of operation D.1-5
- protective earth
 - grounding 6
- proximity switch
 - DeviceNet B.1-5

Q

- quadrature
 - encoder 13, 68

R

- Remote Programmer Access key A.1-1
- requirements 23
- resistive load 63
- RFI
 - emission E.1-2

- immunity E.1-2
- RS232 port
 - ethernet A.1-4
- run-time diagnostics 38

S

- Safety
 - System 5
- safety
 - cleaning 10
 - electrical service & maintenance 9
 - inspection 8
 - operation 8
 - signs 6
- Scan 37
- scan
 - LED 37, 60
- Scan LED 37
- SERCOS 71
 - theory of operation 60
- SERCOS control for MMC C.1-2
- SERCOS port 57
- serial port 58
- shielded twisted pair wiring 54
- shields 32
- signs
 - safety 6
- single point ground (SPG)
 - checklist 28
 - diagram 24
- sink configuration 48
- sizing
 - power supply 26
- source configuration 48
- specifications
 - (IEEE802.3 Ethernet-TCP/IP) A.1-2
 - control cabinet 23
 - DeviceNet B.1-6
 - Ethernet-TCP/IP A.1-7
 - MMC 75
 - Profibus D.1-6
- switch
 - main disconnect 25
 - wiring modules 36
- system
 - environment requirements 23

- grounding 28
- power requirements 23
- power supply 24
- requirements 23

T

- theory of operation
 - analog input 70
 - analog output 67, 71
 - DC input 65
 - encoder 68
 - MMC CPU 62
- troubleshooting 36
 - LEDs 37

U

- user port

- pinout 41

V

- voltage
 - fast transient E.1-2
 - peak reverse 63

W

- warning labels 7
- wiring
 - application 31
 - EMC compliant 31
 - shield twisted pair 54
- workstation
 - power 24

NOTES