

Moment Stiffness Testing

Yaw Stiffness Testing

Torque		Displacement		Radius of Gagehead		Deflection		Stiffness		
N*m	Ft.*Lbs	Millimeters	Inches	Millimeters	Inches	Radians	Degrees	N*m/Radian	Ft.*Lbs./Deg.	In.*Lbs./Deg.
27.12	20	0.000889	0.00004	98.425	3.88	0.000009	0.000518	3002571	38647	463759
40.68	30	0.001905	0.00008			0.000019	0.001109	2101800	27053	324631
54.24	40	0.003175	0.00013			0.000032	0.001848	1681440	21642	259705
67.80	50	0.005715	0.00023			0.000058	0.003327	1167667	15029	180351
81.36	60	0.008255	0.00033			0.000084	0.004805	970062	12486	149830
94.92	70	0.010795	0.00043			0.000110	0.006284	865447	11139	133672
108.48	80	0.013335	0.00053			0.000135	0.007763	800686	10306	123669
122.04	90	0.015875	0.00063			0.000161	0.009241	756648	9739	116867
135.60	100	0.018415	0.00073			0.000187	0.010720	724759	9328	111942

Average Stiffness	1341231	17263	207158
	N*m/Radian	Ft.*Lbs./Deg.	In.*Lbs./Deg.

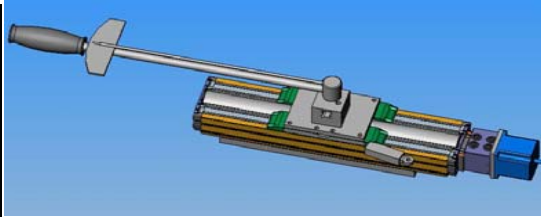

YAW MEASURING SET UP

Pitch Stiffness Testing

Torque		Displacement		Radius of Gagehead		Deflection		Stiffness		
N*m	Ft.*Lbs	Millimeters	Inches	Millimeters	Inches	Radians	Degrees	N*m/Radian	Ft.*Lbs./Deg.	In.*Lbs./Deg.
27.12	20	0.00381	0.00015	98.425	3.88	0.000039	0.002218	700600	9018	108210
40.68	30	0.00508	0.00020			0.000052	0.002957	788175	10145	121737
54.24	40	0.00762	0.00030			0.000077	0.004436	700600	9018	108210
67.80	50	0.01524	0.00060			0.000155	0.008872	437875	5636	67632
81.36	60	0.01778	0.00070			0.000181	0.010350	450386	5797	69564
94.92	70	0.02032	0.00080			0.000206	0.011829	459769	5918	71013

Average Stiffness	589567	7588	91061
	N*m/Radian	Ft.*Lbs./Deg.	In.*Lbs./Deg.

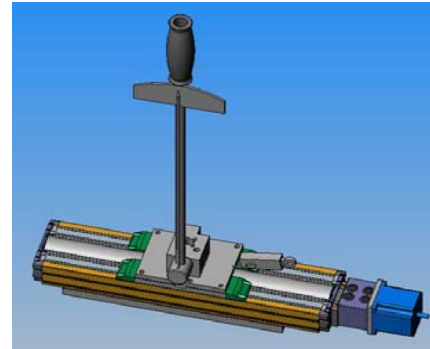

PITCH MEASURING SET UP

Roll Stiffness Testing

Torque		Displacement		Radius of Gagehead		Deflection		Stiffness		
N*m	Ft.*Lbs	Millimeters	Inches	Millimeters	Inches	Radians	Degrees	N*m/Radian	Ft.*Lbs./Deg.	In.*Lbs./Deg.
27.12	20	0.002032	0.00008	74.61	2.94	0.000021	0.001183	1313625	16908	202895
40.68	30	0.00381	0.00015			0.000039	0.002218	1050900	13526	162316
54.24	40	0.00635	0.00025			0.000065	0.003697	840720	10821	129852
67.80	50	0.00889	0.00035			0.000090	0.005175	750643	9662	115940

Average Stiffness	988972	12729	152751
	N*m/Radian	Ft.*Lbs./Deg.	In.*Lbs./Deg.

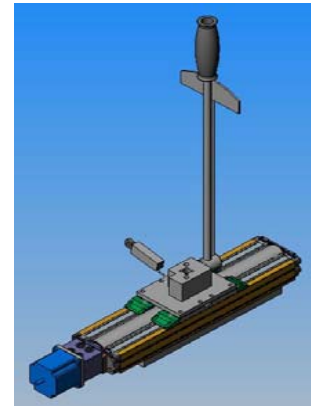

ROLL MEASURING SET UP