

Moment Stiffness Testing

Yaw Stiffness Testing

Torque		Displacement		Radius of Gagehead		Deflection		Stiffness		
N*m	Ft.*Lbs	Millimeters	Inches	Millimeters	Inches	Radians	Degrees	N*m/Radian	Ft.*Lbs./Deg.	In.*Lbs./Deg.
27.12	20	0.00508	0.00020	60.96	2.40	0.000083	0.004775	325440	4189	50265
40.68	30	0.00762	0.00030			0.000125	0.007162	325440	4189	50265
54.24	40	0.0127	0.00050			0.000208	0.011937	260352	3351	40212
67.80	50	0.01524	0.00060			0.000250	0.014324	271200	3491	41888
81.36	60	0.01651	0.00065			0.000271	0.015518	300406	3867	46399
94.92	70	0.01905	0.00075			0.000313	0.017905	303744	3910	46914
108.48	80	0.02032	0.00080			0.000333	0.019099	325440	4189	50265
122.04	90	0.02286	0.00090			0.000375	0.021486	325440	4189	50265
135.60	100	0.024892	0.00098			0.000408	0.023396	332082	4274	51291

Average Stiffness	307727	3961	47530
	N*m/Radian	Ft.*Lbs./Deg.	In.*Lbs./Deg.

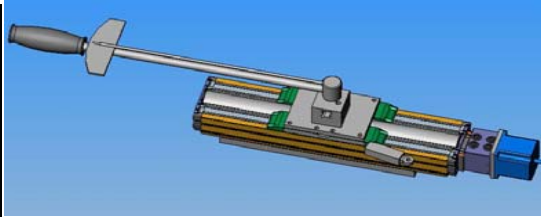

YAW MEASURING SET UP

Pitch Stiffness Testing

Torque		Displacement		Radius of Gagehead		Deflection		Stiffness		
N*m	Ft.*Lbs	Millimeters	Inches	Millimeters	Inches	Radians	Degrees	N*m/Radian	Ft.*Lbs./Deg.	In.*Lbs./Deg.
27.12	20	0.00762	0.00030	60.96	2.40	0.000125	0.007162	216960	2793	33510
40.68	30	0.01016	0.00040			0.000167	0.009549	244080	3142	37699
54.24	40	0.0127	0.00050			0.000208	0.011937	260352	3351	40212
67.80	50	0.01524	0.00060			0.000250	0.014324	271200	3491	41888
81.36	60	0.01651	0.00065			0.000271	0.015518	300406	3867	46399
94.92	70	0.01905	0.00075			0.000313	0.017905	303744	3910	46914

Average Stiffness	266124	3425	41104
	N*m/Radian	Ft.*Lbs./Deg.	In.*Lbs./Deg.

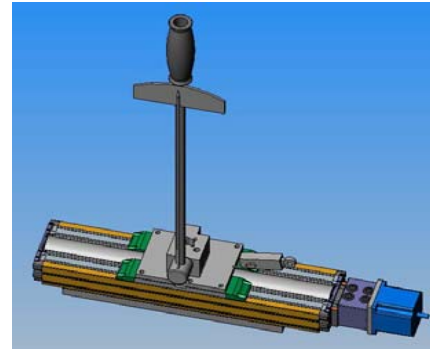

PITCH MEASURING SET UP

Roll Stiffness Testing

Torque		Displacement		Radius of Gagehead		Deflection		Stiffness		
N*m	Ft.*Lbs	Millimeters	Inches	Millimeters	Inches	Radians	Degrees	N*m/Radian	Ft.*Lbs./Deg.	In.*Lbs./Deg.
27.12	20	0.01397	0.00055	47.50	1.87	0.000229	0.013130	118342	1523	18278
40.68	30	0.02032	0.00080			0.000333	0.019099	122040	1571	18850
54.24	40	0.03048	0.00120			0.000500	0.028648	108480	1396	16755
67.80	50	0.03556	0.00140			0.000583	0.033423	116229	1496	17952

Average Stiffness	116273	1497	17959
	N*m/Radian	Ft.*Lbs./Deg.	In.*Lbs./Deg.

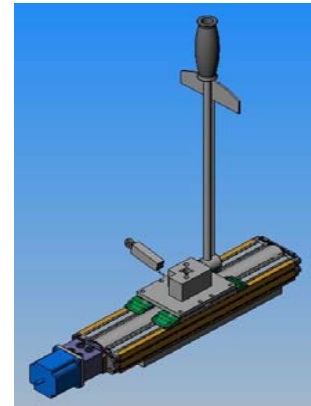

ROLL MEASURING SET UP